

821G
921G
Stage IV
Wheel Loader

SERVICE MANUAL

Part number 51428216

English

November 2017

© 2017 CNH Industrial Italia S.p.A. All Rights Reserved.

CASE
CONSTRUCTION



SERVICE MANUAL

821G WHEEL LOADER XR-EH, NEW CAB TIER4B, 821G WHEEL LOADER ZBAR-EH, NEW CAB TIER4B, 821G Wheel Loader XR-EH, New cab, Tier 4B, Multipurpose, 821G Wheel Loader ZBAR-EH, New cab, Tier 4B, Multipurpose, 921G WHEEL LOADER XR-EH, NEW CAB TIER4B, 921G WHEEL LOADER ZBAR-EH, NEW CAB TIER4B, 921G Wheel Loader XR-EH, New cab, Tier 4B, Multipurpose, 921G Wheel Loader ZBAR-EH, New cab, Tier 4B, Multipurpose

Link Product / Engine

Product	Market Product	Engine
821G WHEEL LOADER ZBAR-EH, NEW CAB TIER4B	Europe	F4HFE613S*B004
821G Wheel Loader ZBAR-EH, New cab, Tier 4B, Multipurpose	Europe	F4HFE613S*B004
821G WHEEL LOADER XR-EH, NEW CAB TIER4B	Europe	F4HFE613S*B004
821G Wheel Loader XR-EH, New cab, Tier 4B, Multipurpose	Europe	F4HFE613S*B004
921G WHEEL LOADER ZBAR-EH, NEW CAB TIER4B	Europe	F4HFE613R*B006
921G Wheel Loader ZBAR-EH, New cab, Tier 4B, Multipurpose	Europe	F4HFE613R*B006
921G WHEEL LOADER XR-EH, NEW CAB TIER4B	Europe	F4HFE613R*B006
921G Wheel Loader XR-EH, New cab, Tier 4B, Multipurpose	Europe	F4HFE613R*B006

<https://www.ebooklibonline.com>

Hello dear friend!

Thank you very much for reading.

Enter the link into your browser.

The full manual is available for immediate download.

<https://www.ebooklibonline.com>

Contents

INTRODUCTION

Engine	10
[10.001] Engine and crankcase	10.1
[10.216] Fuel tanks	10.2
[10.202] Air cleaners and lines	10.3
[10.500] Selective Catalytic Reduction (SCR) exhaust treatment.....	10.4
[10.400] Engine cooling system	10.5
[10.414] Fan and drive	10.6
[10.310] Aftercooler.....	10.7
[10.304] Engine lubrication system.....	10.8
Transmission	21
[21.113] Powershift transmission	21.1
[21.155] Powershift transmission internal components.....	21.2
[21.700] Torque converter	21.3
Four-Wheel Drive (4WD) system	23
[23.314] Drive shaft.....	23.1
Front axle system	25
[25.100] Powered front axle	25.1
[25.102] Front bevel gear set and differential	25.2
[25.108] Final drive hub, steering knuckles, and shafts	25.3
Rear axle system	27
[27.100] Powered rear axle.....	27.1
[27.106] Rear bevel gear set and differential	27.2
[27.120] Planetary and final drives	27.3
Brakes and controls	33
[33.202] Hydraulic service brakes	33.1

[33.110] Parking brake or parking lock	33.2
Hydraulic systems.....	35
[35.000] Hydraulic systems.....	35.1
[35.300] Reservoir, cooler, and filters.....	35.2
[35.106] Variable displacement pump	35.3
[35.359] Main control valve	35.4
[35.357] Pilot system	35.5
[35.204] Remote control valves	35.6
[35.752] Hydraulic fan drive cooling system.....	35.7
[35.701] Front loader arm hydraulic system	35.8
[35.723] Front loader bucket hydraulic system	35.9
[35.734] Tool quick coupler hydraulic system	35.10
Frames and ballasting	39
[39.100] Frame	39.1
Steering.....	41
[41.101] Steering control	41.1
[41.200] Hydraulic control components.....	41.2
[41.216] Cylinders	41.3
[41.910] Auxiliary steering	41.4
Wheels	44
[44.511] Front wheels.....	44.1
[44.520] Rear wheels.....	44.2
Cab climate control	50
[50.200] Air conditioning	50.1
Electrical systems	55
[55.100] Harnesses and connectors.....	55.1
[55.201] Engine starting system	55.2
[55.301] Alternator	55.3

[55.302] Battery.....	55.4
[55.988] Selective Catalytic Reduction (SCR) electrical system	55.5
[55.989] Exhaust Gas Recirculation (EGR) electrical system	55.6
[55.512] Cab controls.....	55.7
[55.415] Loader arm and bucket control system	55.8
[55.530] Camera.....	55.9
[55.DTC] FAULT CODES.....	55.10
Front loader and bucket.....	82
[82.100] Arm.....	82.1
[82.300] Bucket.....	82.2
Platform, cab, bodywork, and decals.....	90
[90.150] Cab.....	90.1
[90.120] Mechanically-adjusted operator seat.....	90.2
[90.124] Pneumatically-adjusted operator seat.....	90.3
[90.105] Machine shields and guards	90.4



INTRODUCTION

Safety rules

Personal safety





This is the safety alert symbol. It is used to alert you to potential personal injury hazards. Obey all safety messages that follow this symbol to avoid possible death or injury.

Throughout this manual you will find the signal words DANGER, WARNING, and CAUTION followed by special instructions. These precautions are intended for the personal safety of you and those working with you.

Read and understand all the safety messages in this manual before you operate or service the machine.

 DANGER indicates a hazardous situation that, if not avoided, will result in death or serious injury.

 WARNING indicates a hazardous situation that, if not avoided, could result in death or serious injury.

 CAUTION indicates a hazardous situation that, if not avoided, could result in minor or moderate injury.

FAILURE TO FOLLOW DANGER, WARNING, AND CAUTION MESSAGES COULD RESULT IN DEATH OR SERIOUS INJURY.

Machine safety

NOTICE: Notice indicates a situation that, if not avoided, could result in machine or property damage.

Throughout this manual you will find the signal word Notice followed by special instructions to prevent machine or property damage. The word Notice is used to address practices not related to personal safety.

Information

NOTE: Note indicates additional information that clarifies steps, procedures, or other information in this manual.

Throughout this manual you will find the word Note followed by additional information about a step, procedure, or other information in the manual. The word Note is not intended to address personal safety or property damage.

Personal safety

Carefully read this Manual before proceeding with maintenance, repairs, refuelling or other machine operations.

Repairs have to be carried out only by authorized and instructed staff; specific precautions have to be taken when grinding, welding or when using mallets or heavy hammers.

Non-authorized persons are not allowed to repair or carry out maintenance on this machine. Do not carry out any work on the equipment without prior authorization.

Ask your employer about the safety instructions in force and safety equipment.

Nobody should be allowed in the cab during machine maintenance unless he is a qualified operator helping with the maintenance work.

If it is necessary to move the equipment to carry out repairs or maintenance, do not lift or lower the equipment from any other position than the operator's seat.

Never carry out any operation on the machine when the engine is running, except when specifically indicated.

Stop the engine and ensure that all pressure is relieved from hydraulic circuits before removing caps, covers, valves, etc.

All repair and maintenance operations should be carried out with the greatest care and attention.

Service stairs and platforms used in a workshop or in the field should be built in compliance with the safety rules in force.

Any functional disorders, especially those affecting the safety of the machine, should therefore be rectified immediately.

⚠ DANGER

Unexpected movement!

Make sure parking brake is applied. Secure machine with wheel chocks.

Failure to comply will result in death or serious injury.

D0013A

Before performing any work on the machine, attach a maintenance in progress tag. This tag can be applied on the left-hand control lever, safety lever or cab door.

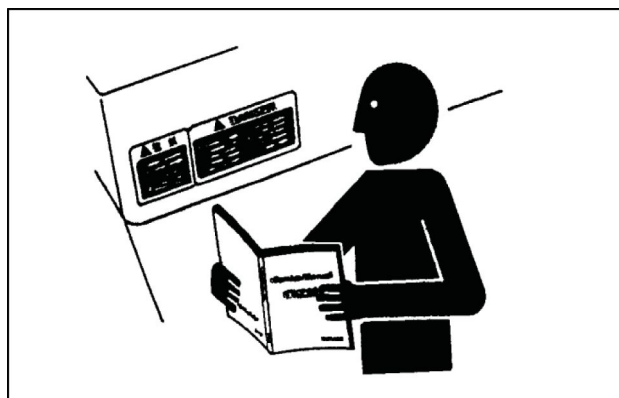

TULI12WEX2004AA 1

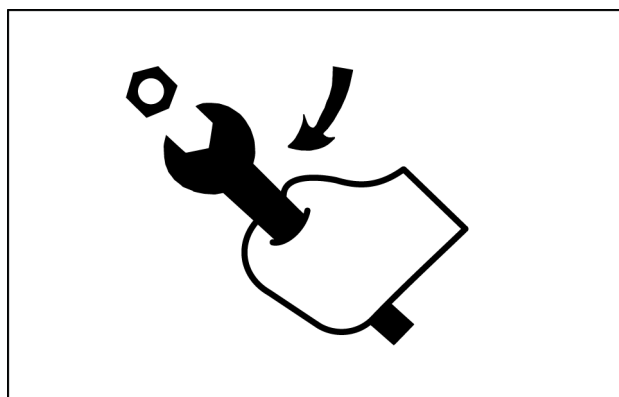

TULI12WEX2005AA 2

Product identification

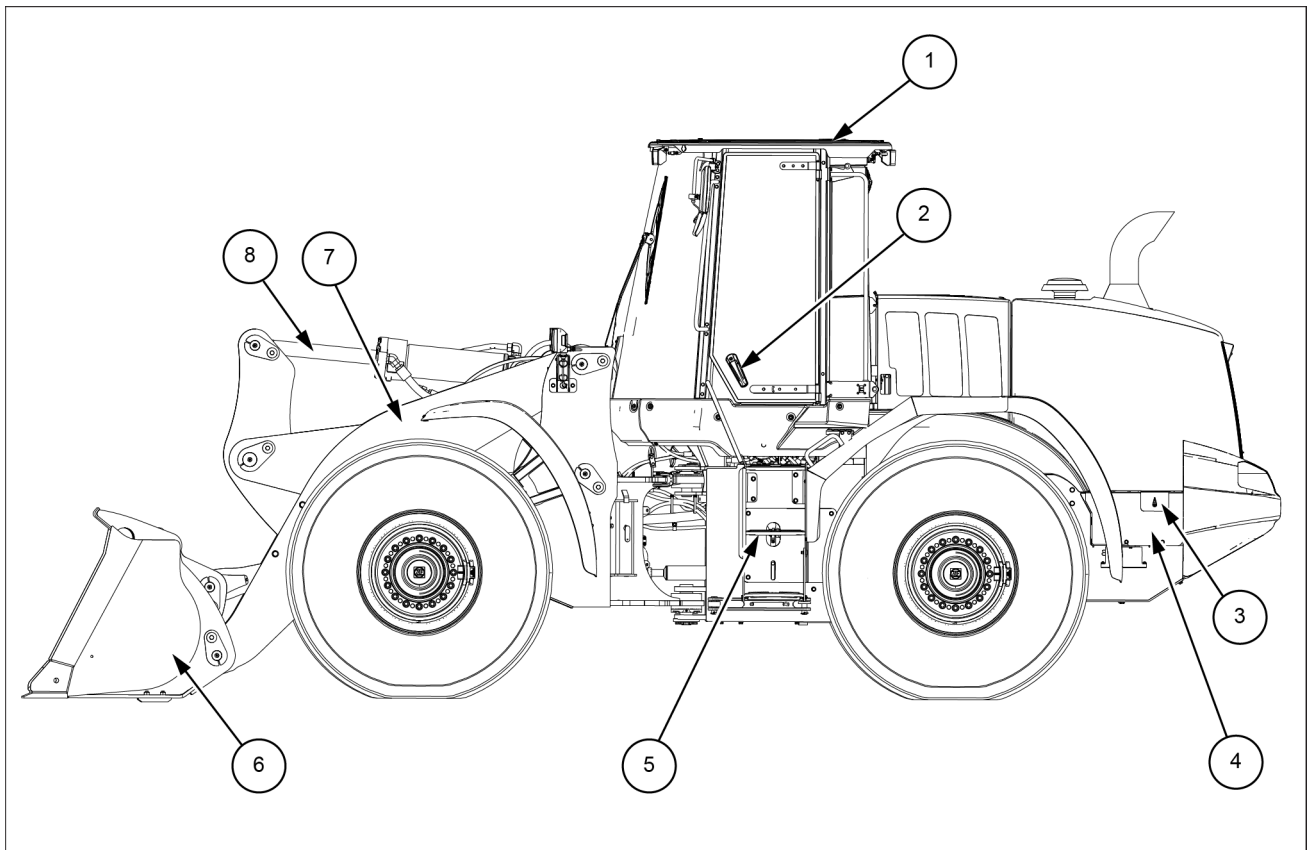

LEIL17WHL1703FB 1

- | | |
|---|---------------------|
| 1. Roll Over Protection System (ROPS) cab | 5. Steps |
| 2. Cab door handle | 6. Bucket |
| 3. Timed disconnect switch and optional battery jump post | 7. Loader lift arms |
| 4. Battery access | 8. Bucket cylinder |

INTRODUCTION

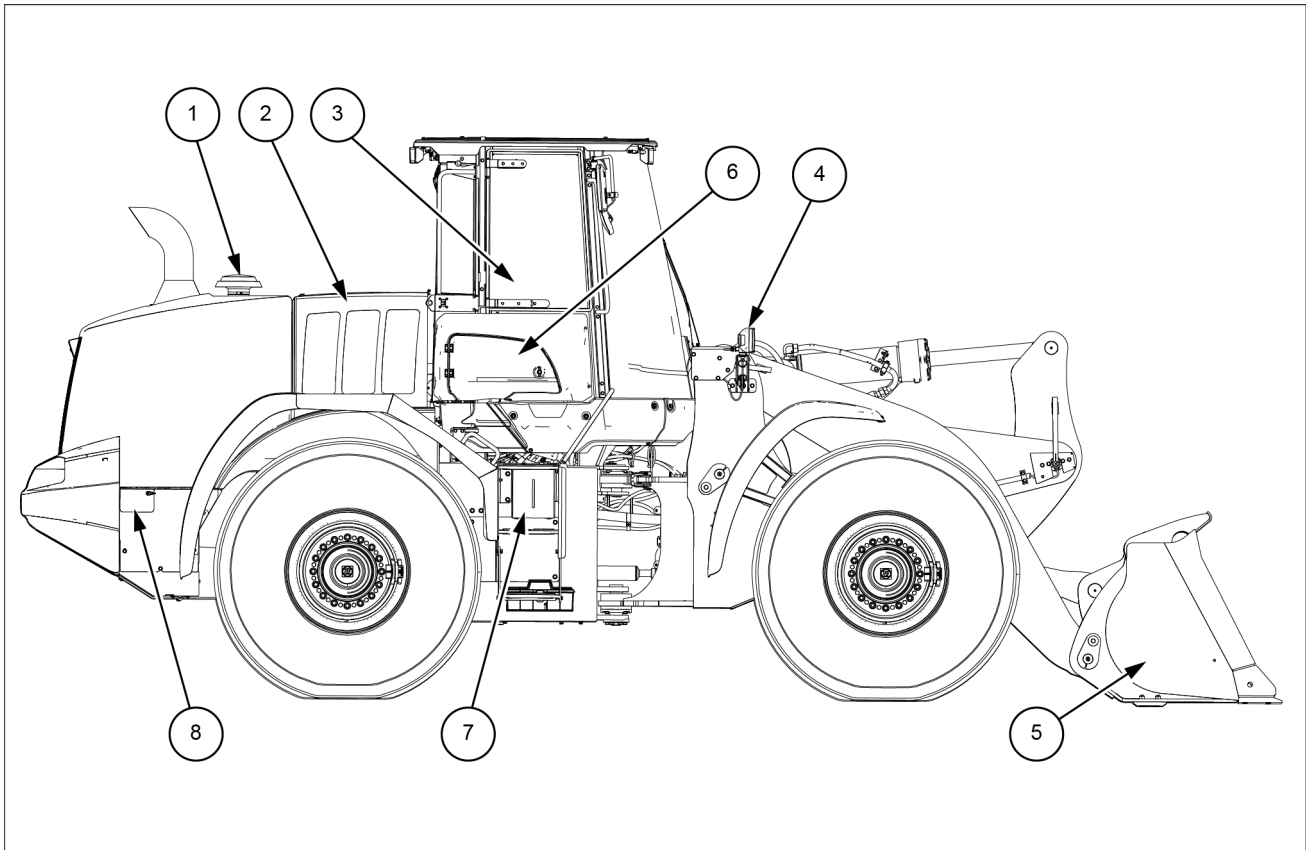

LEIL17WHL1701FB 2

1. Pre-cleaner
2. Sliding access panel
3. Cab side window
4. Driving lights
5. Handrail
6. Cab air filter door
7. Windshield washer reservoir
8. **Diesel Exhaust Fluid (DEF)/AdBlue®** fill tank
9. Tool box



SERVICE MANUAL

Engine

821G WHEEL LOADER XR-EH, NEW CAB TIER4B, 821G WHEEL LOADER ZBAR-EH, NEW CAB TIER4B, 821G Wheel Loader XR-EH, New cab, Tier 4B, Multipurpose, 821G Wheel Loader ZBAR-EH, New cab, Tier 4B, Multipurpose, 921G WHEEL LOADER XR-EH, NEW CAB TIER4B, 921G WHEEL LOADER ZBAR-EH, NEW CAB TIER4B, 921G Wheel Loader XR-EH, New cab, Tier 4B, Multipurpose, 921G Wheel Loader ZBAR-EH, New cab, Tier 4B, Multipurpose

Engine - General specification

821G WHEEL LOADER XR-EH, NEW CAB TIER4B	WE
821G WHEEL LOADER ZBAR-EH, NEW CAB TIER4B	WE
821G Wheel Loader XR-EH, New cab, Tier 4B, Multipurpose	WE
821G Wheel Loader ZBAR-EH, New cab, Tier 4B, Multipurpose	WE

Engine with 4 Speed Transmission	
A. Low idle	870 RPM to 930 RPM
Alternate low idle	670 RPM to 730 RPM
Alternate Accelerated Idle	1270 RPM to 1330 RPM
B. Maximum No Load RPM	2065 RPM to 2185 RPM
C. Converter Stall	1855 RPM to 2055 RPM
D. Hydraulic Stall	2065 RPM to 2265 RPM
E. Converter and Hydraulic Stall	1550 RPM to 1750 RPM
Temperature of the torque converter oil	82 – 104 °C (180 – 219 °F)
Temperature of the hydraulic oil	54 – 57 °C (129 – 135 °F)

Engine with 5 Speed Transmission	
A. Low idle	870 RPM to 930 RPM
Alternate low idle	670 RPM to 730 RPM
Alternate Accelerated Idle	1270 RPM to 1330 RPM
B. Maximum No Load RPM	2065 RPM to 2185 RPM
C. Converter Stall	1912 RPM to 2112 RPM
D. Hydraulic Stall	2070 RPM to 2270 RPM
E. Converter and Hydraulic Stall	1590 RPM to 1790 RPM
Temperature of the torque converter oil	82 – 104 °C (180 – 219 °F)
Temperature of the hydraulic oil	54 – 57 °C (129 – 135 °F)

NOTE: hydraulic Stall and Converter and Hydraulic Stall RPM values are read while the lift arms are rising with the bucket held rolled back and the engine at Wide Open Throttle (WOT) in max power mode with transmission in manual mode and in 3rd gear.

Engine - General specification

921G WHEEL LOADER XR-EH, NEW CAB TIER4B	WE
921G WHEEL LOADER ZBAR-EH, NEW CAB TIER4B	WE
921G Wheel Loader XR-EH, New cab, Tier 4B, Multipurpose	WE
921G Wheel Loader ZBAR-EH, New cab, Tier 4B, Multipurpose	WE

Engine with 4 Speed Transmission	
A. Low idle	870 RPM to 930 RPM
Alternate low idle	670 RPM to 730 RPM
Alternate Accelerated Idle	1270 RPM to 1330 RPM
B. Maximum No Load RPM	2115 RPM to 2200 RPM
C. Converter Stall	1835 RPM to 2035 RPM
D. Hydraulic Stall	2075 RPM to 2275 RPM
E. Converter and Hydraulic Stall	1560 RPM to 1760 RPM
Temperature of the torque converter oil	82 – 104 °C (180 – 219 °F)
Temperature of the hydraulic oil	54 – 57 °C (129 – 135 °F)

Engine with 5 Speed Transmission	
A. Low idle	870 RPM to 930 RPM
Alternate low idle	670 RPM to 730 RPM
Alternate Accelerated Idle	1270 RPM to 1330 RPM
B. Maximum No Load RPM	2115 RPM to 2200 RPM
C. Converter Stall	1837 RPM to 2037 RPM
D. Hydraulic Stall	2127 RPM to 2327 RPM
E. Converter and Hydraulic Stall	1560 RPM to 1760 RPM
Temperature of the torque converter oil	82 – 104 °C (180 – 219 °F)

Temperature of the hydraulic oil	54 – 57 °C (129 – 135 °F)
----------------------------------	----------------------------------

NOTE: hydraulic Stall and Converter and Hydraulic Stall RPM values are read while the lift arms are rising with the bucket held rolled back and the engine at Wide Open Throttle (WOT) in max power mode with transmission in manual mode and in 3rd gear.

Engine - Engine horse power

821G WHEEL LOADER XR-EH, NEW CAB TIER4B	WE
821G WHEEL LOADER ZBAR-EH, NEW CAB TIER4B	WE
821G Wheel Loader XR-EH, New cab, Tier 4B, Multipurpose	WE
821G Wheel Loader ZBAR-EH, New cab, Tier 4B, Multipurpose	WE

Design characteristics	
Displacement	6728 cm³ (410.6 in³)
Engine Configuration	6 cylinder in line, 4 stroke
Intake Air	Turbocharged, 4 valves/cyl
Fuel injection	High pressure common rail
EGR	No

Performance	
Altitude Capability	3000 m (9842.5 ft)
High Idle Speed	2212 RPM
Low Idle Speed	700 RPM
Rated Power	169 kW at 2000 RPM
Peak Torque	1184 kW at 1300 RPM

Engine - Engine and crankcase

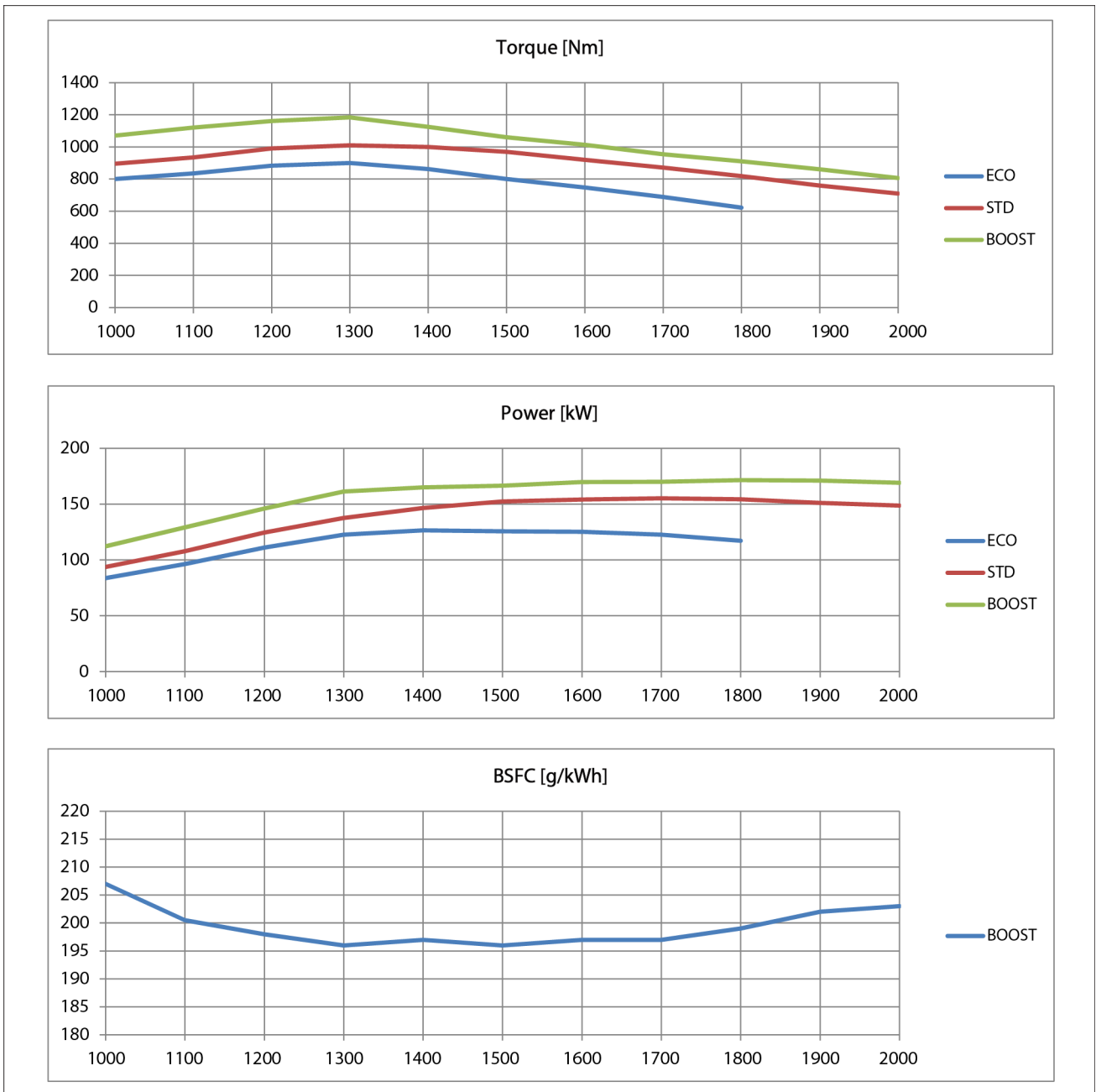

LEIL17WHL0358GA 1

NOTE: performances detected at engine test bench.

NOTE: BSFC indicates the Brake Specific Fuel Consumption.

Engine - Engine horse power

921G WHEEL LOADER XR-EH, NEW CAB TIER4B	WE
921G WHEEL LOADER ZBAR-EH, NEW CAB TIER4B	WE
921G Wheel Loader XR-EH, New cab, Tier 4B, Multipurpose	WE
921G Wheel Loader ZBAR-EH, New cab, Tier 4B, Multipurpose	WE

Design characteristics	
Displacement	6728 cm³ (410.6 in³)
Engine Configuration	6 cylinder in line, 4 stroke
Intake Air	Turbocharged, 4 valves/cyl
Fuel injection	High pressure common rail
EGR	No

Engine - Engine and crankcase

Performance	
Altitude Capability	3000 m (9842.5 ft)
High Idle Speed	2175 RPM
Low Idle Speed	700 RPM
Rated Power	183 kW at 2000 RPM
Peak Torque	1300 kW at 1300 RPM

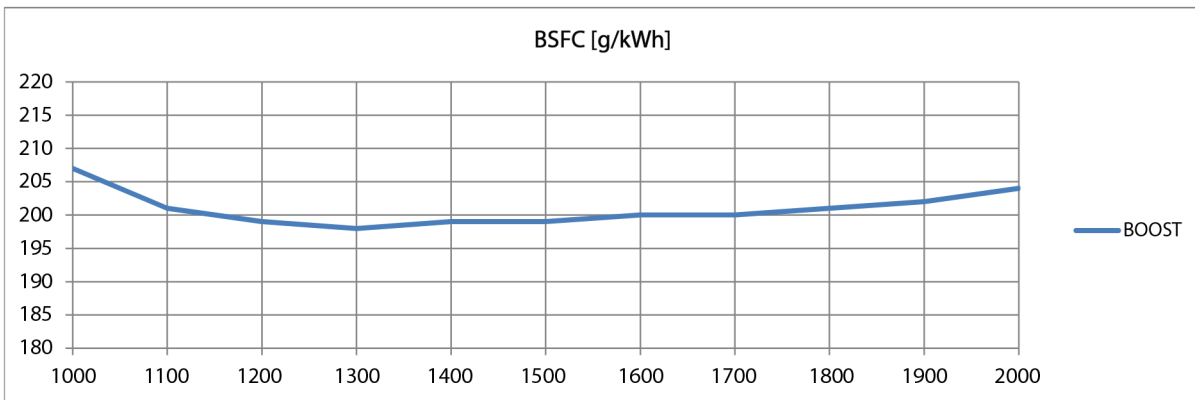
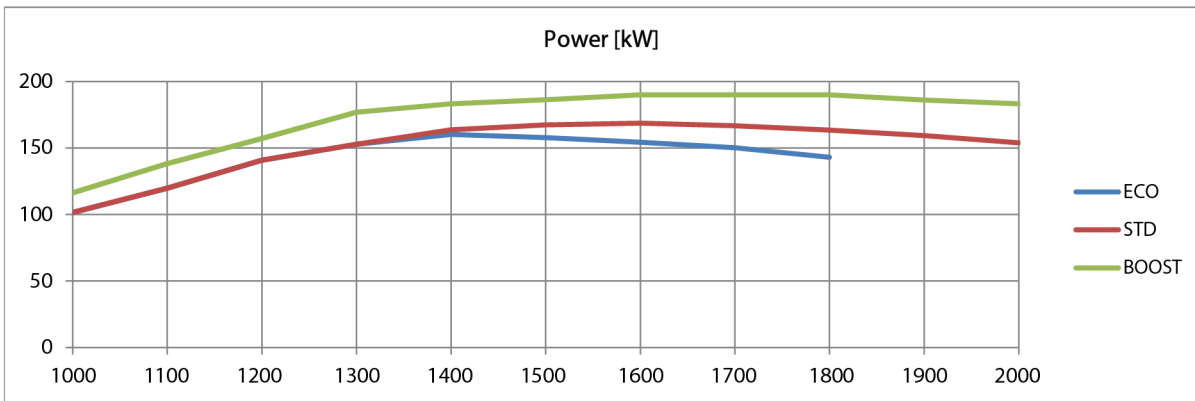
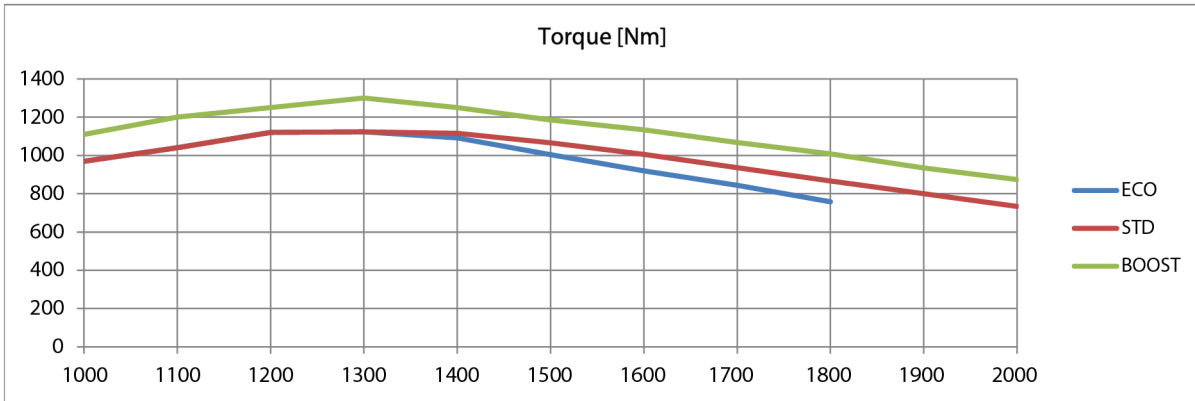

LEIL17WHL0359GA 1

NOTE: performances detected at engine test bench.

NOTE: BSFC indicates the Brake Specific Fuel Consumption.

Engine - Remove

NOTE: emissions sensors mounted in the exhaust stream are sensitive to extreme vibrations. Use of tools that generate extreme vibrations, such as impact wrenches and hammers, will result in damage to emission sensors. Avoid using these tools during any service procedure in close proximity of emission sensors. If the use of these tools cannot be avoided, remove the sensors using extreme caution prior to performing any service procedure.

1. Park the machine on a level surface and lower the bucket to the ground. Put the articulation lock in LOCKED position and stop the engine.

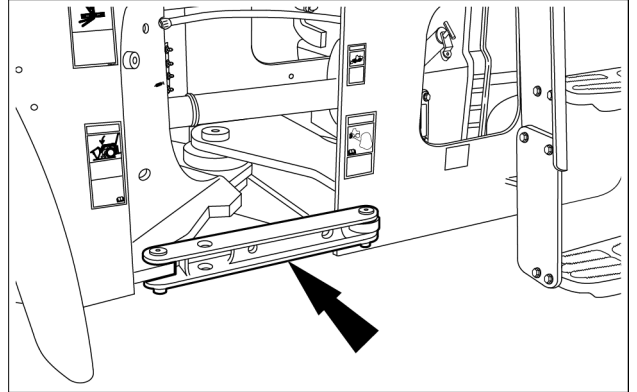

LEIL16WHL0048AB 1

2. Actuate the brake pedal several times to discharge the brake accumulators.

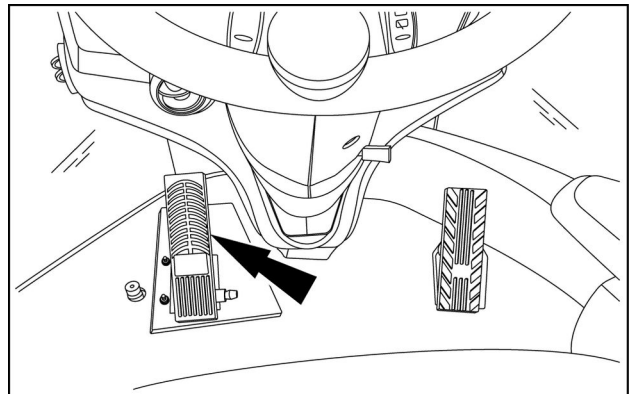

LEIL15WHL0564AA 2

3. Put the key switch in ON position.
Put the control switch in ON position.
Move the control lever(s) back and forth at least 30 times to release any pressure from the hydraulic circuit.
Put the key switch in OFF position.

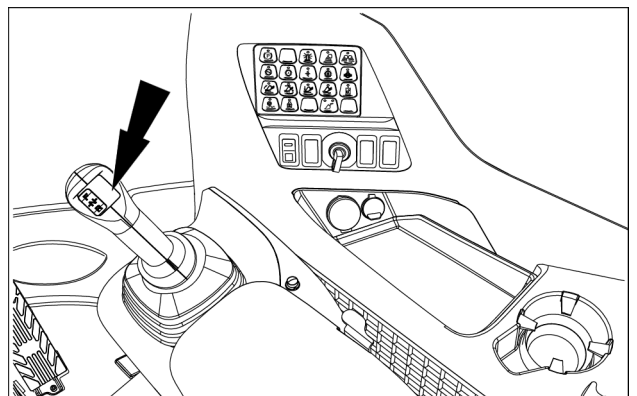

LEIL16WHL1286AA 3

4. Raise the grill located above the cooler box just behind the cab. Then slowly loosen the hydraulic reservoir filler cap to release pressure in the reservoir.

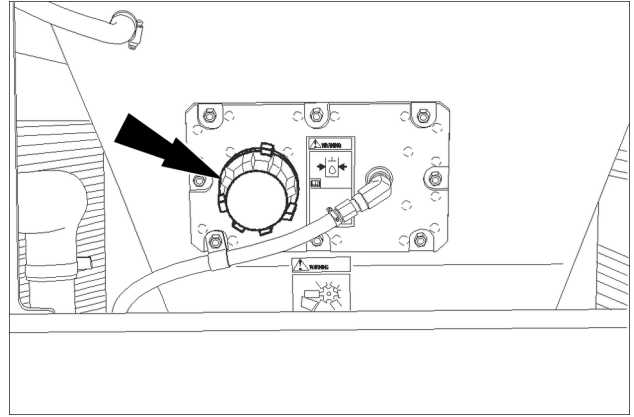

RCPH10WHL099BAL 4

5. Locate the timed disconnect switch and the hood raise switch in the battery box. Raise the engine hood and put the timed disconnect switch in the OFF position.

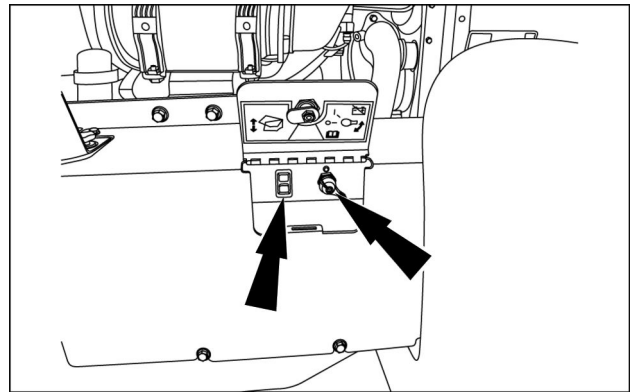

RCPH10WHL106AAH 5

6. Unhook the rubber T-handle (1) and raise the upper panel (2). Make sure that the security levers are blocked.

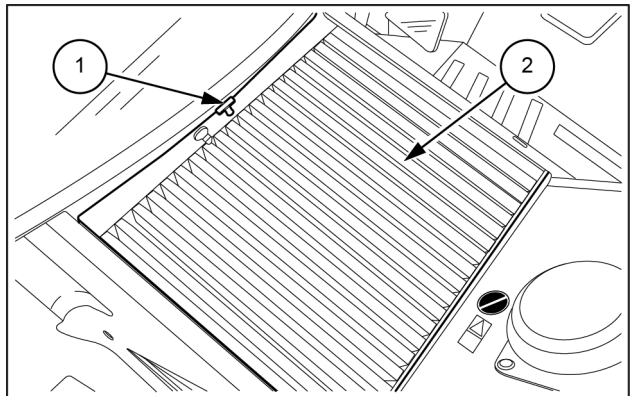

LEIL13WHL0137AB 6

7. Raise both side panels (1). Then remove the thumb screws (2) and inner fender panels (3).

NOTE: right-hand side of the machine is shown. The operation is similar for the left-hand side.

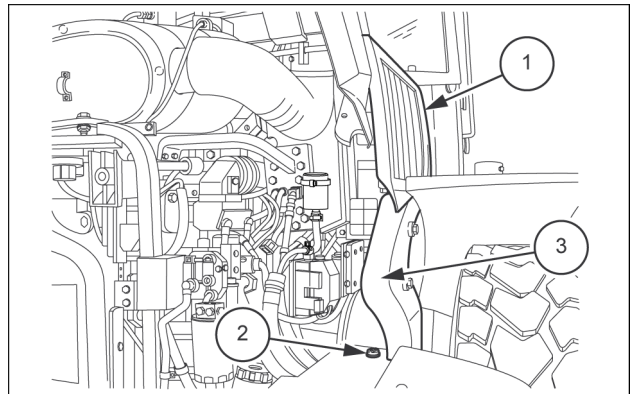

LEIL13WHL0612AB 7

8. Place a suitable container below the radiator drain plug, remove the radiator cap and the radiator drain plug (see the arrow in figure) to drain the engine coolant. Then reinstall the radiator drain plug and the radiator cap after coolant has drained.

NOTE: see machine specifications for cooling system volume.

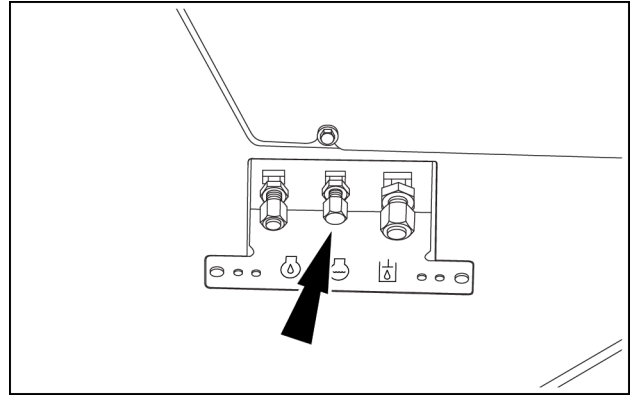

LEIL16WHL0198AA 8

9. Place a suitable container below the engine oil drain plug (see the arrow in figure). Remove the engine oil drain plug and drain oil into container. Then reinstall the engine oil drain plug.

NOTE: see machine specifications for engine oil sump volume.

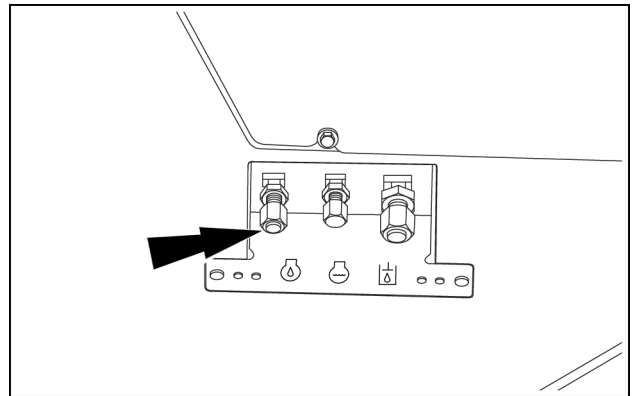

LEIL16WHL0198AA 9

10. Remove the drain hose (1) from the frame bracket (2).

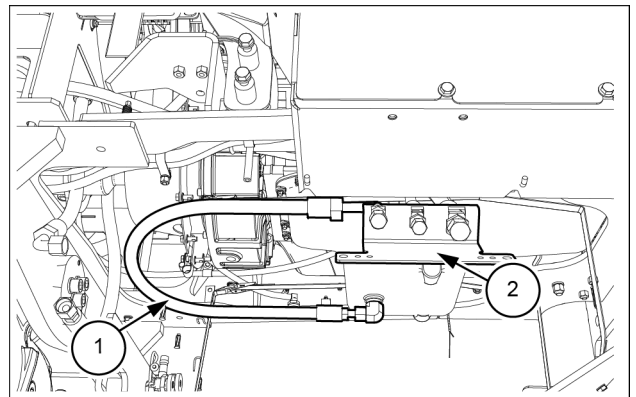

LEIL16WHL1250AB 10

11. Double up a nylon lifting strap and slide through the exhaust stack (1) on the engine hood.

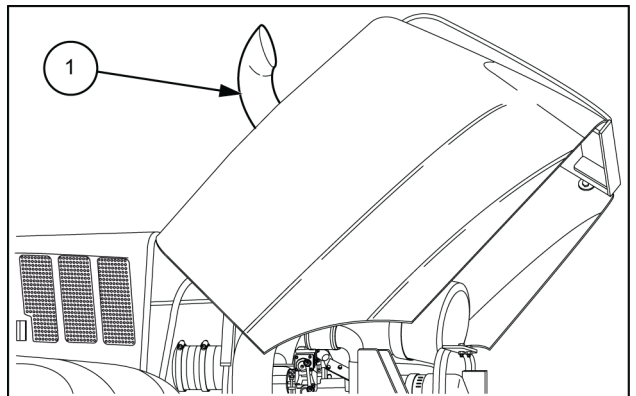

LEIL13WHL0552AB 11

12. Place a solid steel bar or pipe through the strap loop inside the engine hood and attach the strap to a suitable lifting device.
Raise the engine hood with the strap to release tension on the lifting motor.

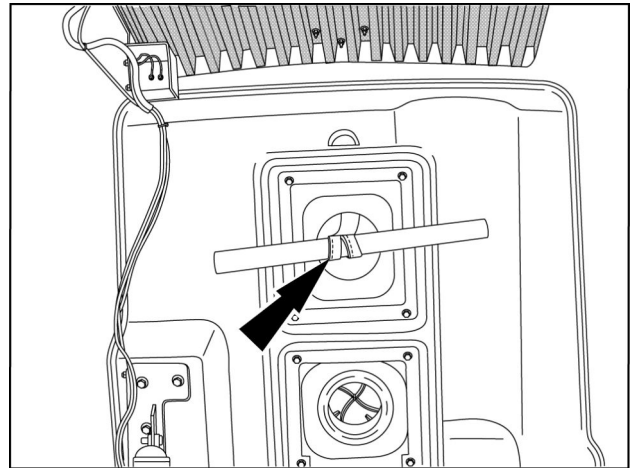

RAPH12WEL0600AA 12

13. If machine is equipped with a rearview camera, tag and disconnect the connector (1) of the rearview camera wire harness (3). Cut the wire ties (2) that hold the rearview camera wire harness (3) to the rear grill.

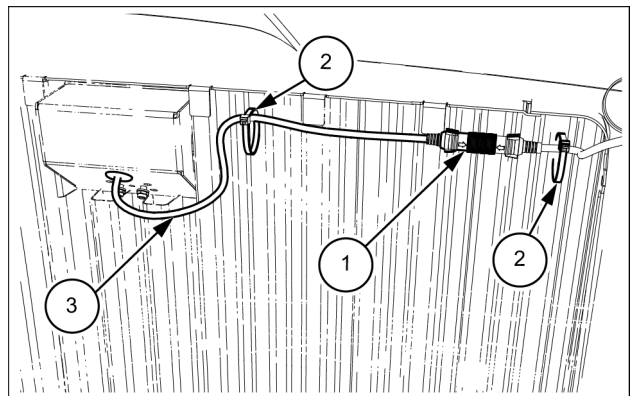

LEIL16WHL0849AB 13

14. Cut the wire ties and remove the rearview camera wire harness from the engine hood. Place the rearview camera wire harness off to the side in a safe location.

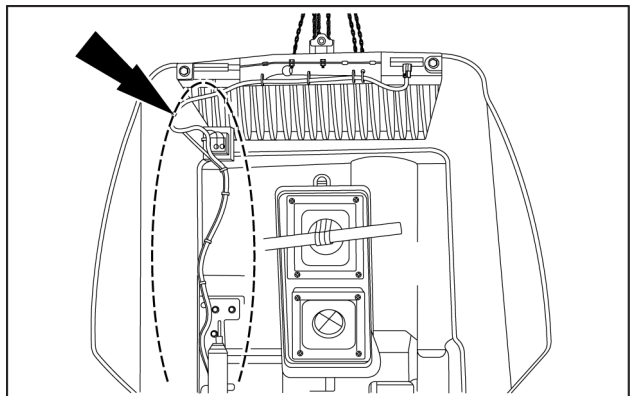

LEIL13WHL0140AB 14

15. Remove the engine hood wire harness clamp (1) from the cooler housing.
Tag and remove the engine hood ground wire (2) from cooler housing.

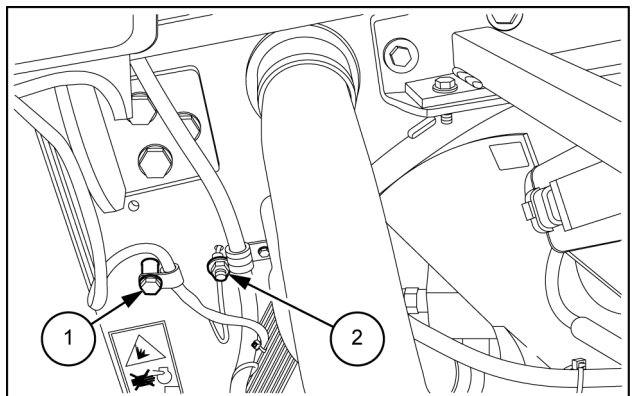

LEIL13WHL0149AB 15

16. Tag and disconnect the engine hood wiring harness connector (1) from the rear chassis wiring harness connector. Remove the engine hood wire harness clamp (2) from the fan guard.

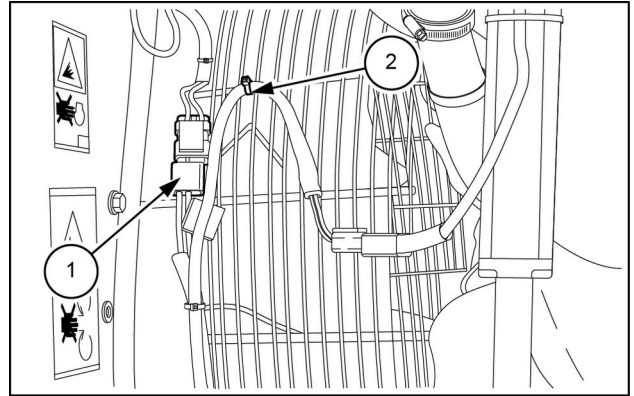

LEIL13WHL0150AB 16

17. Have another person to balance the hood and LOOSEN the hood hinge mounting bolts (see the arrows in figure) from the cooler frame.

NOTE: do not remove the engine hood hinge mounting bolts at this time.

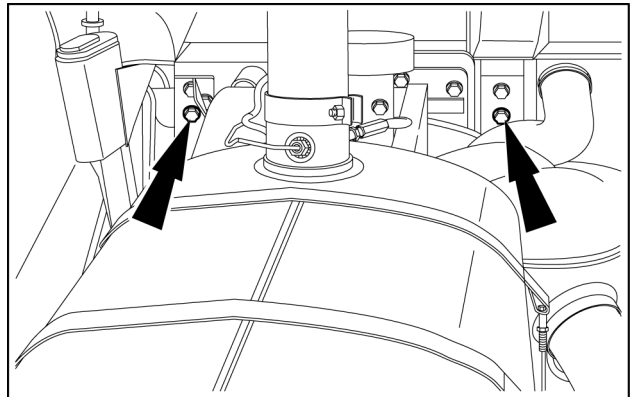

LEIL13WHL0142AB 17

18. Disconnect the wiring harness (5). Put the timed disconnect switch in the ON position. Retract the lifting motor cylinder (1) and remove the clevis pin (3) and the cotter pin (4) from the bottom of the lifting motor cylinder (1). Separate the lifting motor cylinder (1) from the hood support strut (2).

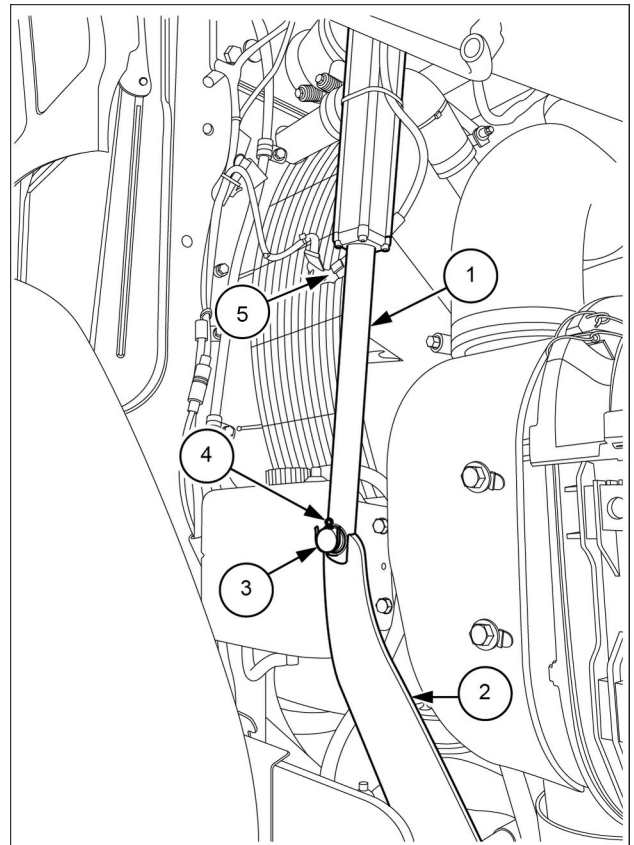

LEIL16WHL1837BB 18

- Put the timed disconnect switch **(1)** in OFF position. Remove the battery cover and disconnect ground lead from the batteries **(2)**.

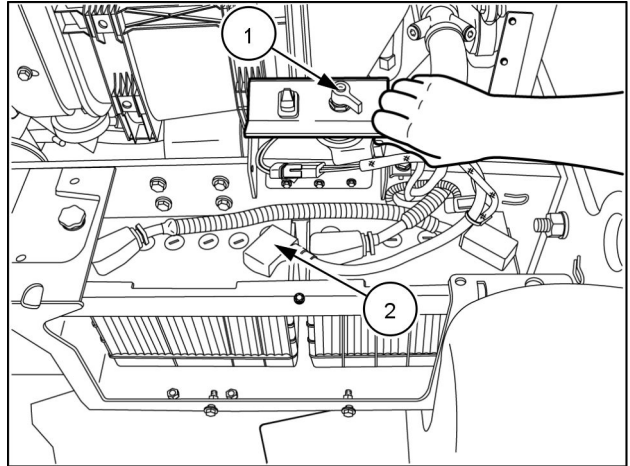

RAPH12WEL0608AA 19

- Have another person to balance the hood and remove the hood hinge mounting bolts (see the arrows in figure) from the cooler frame.

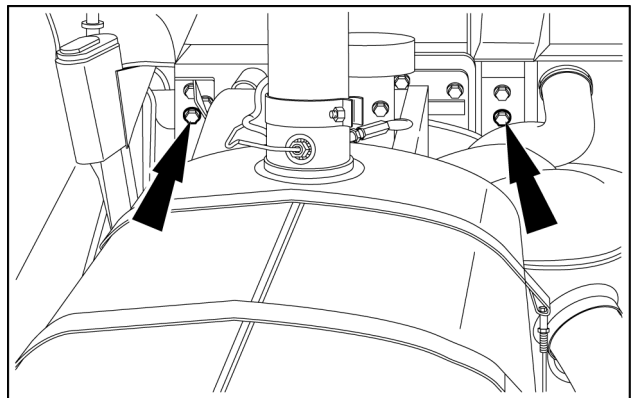

LEIL13WHL0142AB 20

- Carefully raise and remove the engine hood from the machine. Lower the engine hood onto a suitable platform and disconnect lifting equipment from the exhaust stack **(1)**.

NOTE: radiator overflow hose may interfere with left-hand hood hinge movement and hood removal.

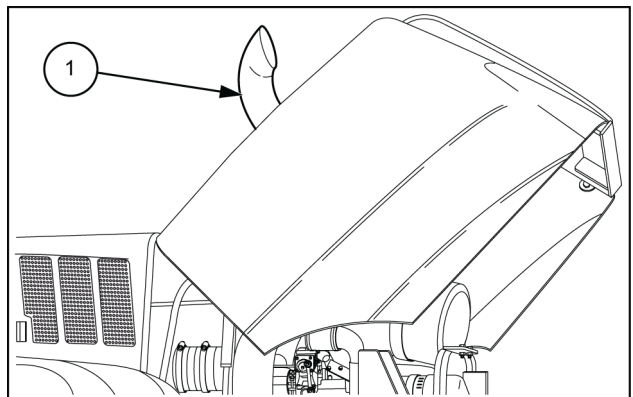

LEIL13WHL0552AB 21

- Tag and disconnect the engine wiring harness connector from the air filter restriction switch.

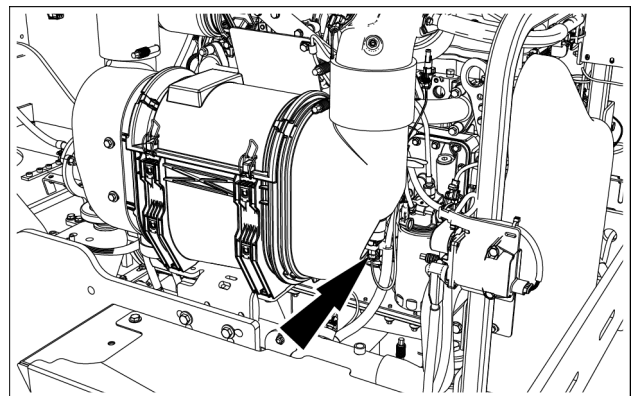

LEIL16WHL0573AB 22

23. Tag and disconnect the engine wiring harness connector from the air inlet humidity sensor (1).

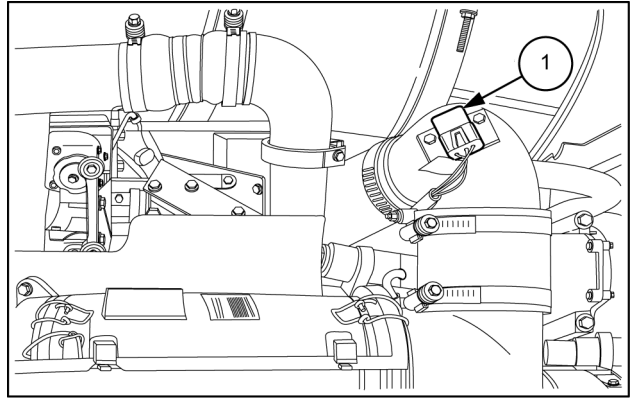

LEIL13WHL0143AB 23

24. Loosen the clamp (1) on the crankcase ventilation hose (2) and disconnect the hose.

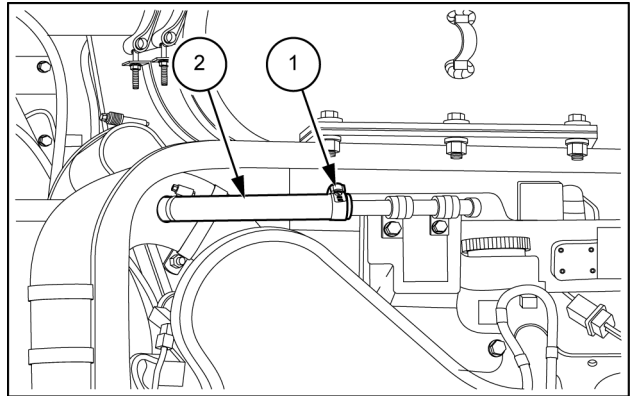

LEIL13WHL0144AB 24

25. Loosen the clamps on the turbocharger and air filter housing. Remove the intake air hose (1). Cover the turbocharger inlet to prevent debris entry.

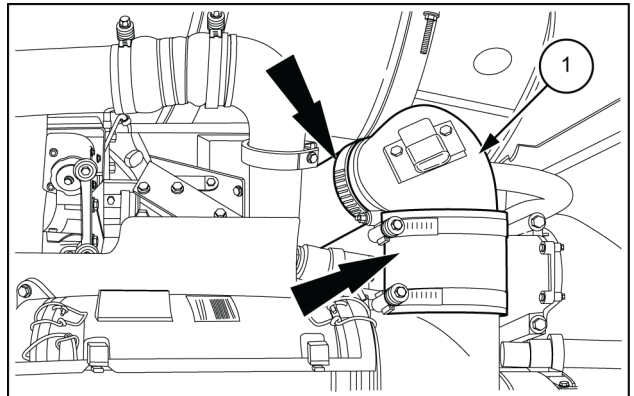

LEIL13WHL0145AB 25

26. Loosen the clamp from the elbow connected to the turbocharger.

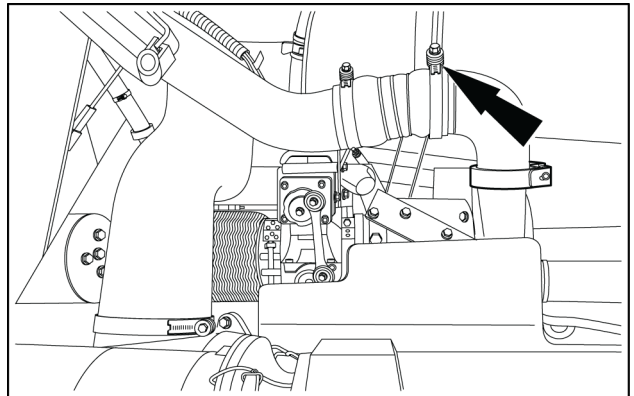

LEIL14WHL0203AB 26

27. Loosen the clamp on the hose at the after cooler inlet and remove the tube.

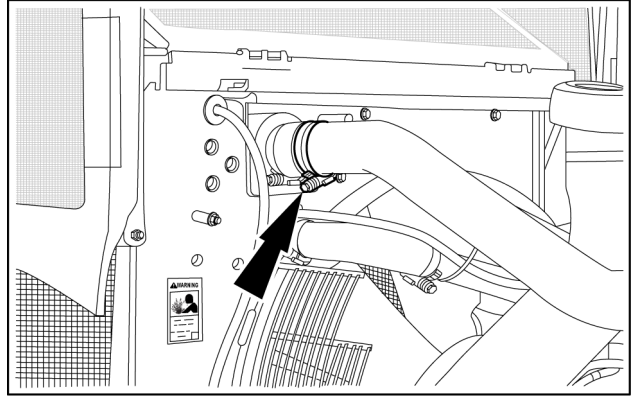

LEIL13WHL0147AB 27

28. Loosen the clamp on the air inlet hose at the air filter housing.

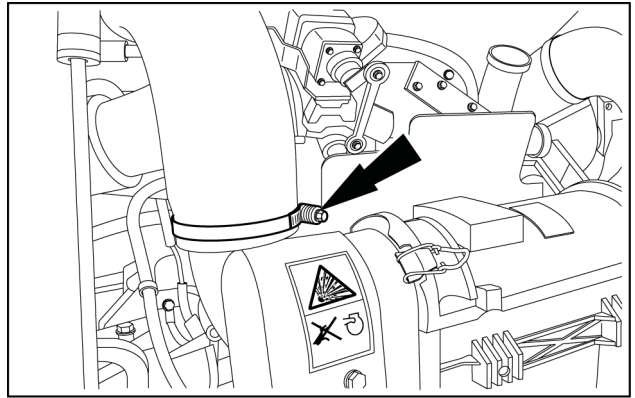

LEIL13WHL0148AB 28

29. Loosen the clamp **(1)** on the air inlet hose **(2)** at the exhaust support bracket. Remove the air inlet hose **(2)**.

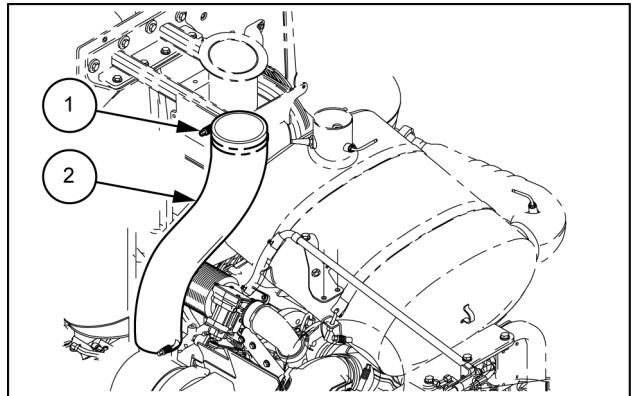

LEIL13WHL0151AB 29

30. Remove the securing bolts **(1)** with the related washers and nuts. Remove the bracket **(2)** with the air filter **(3)** as an assembly.

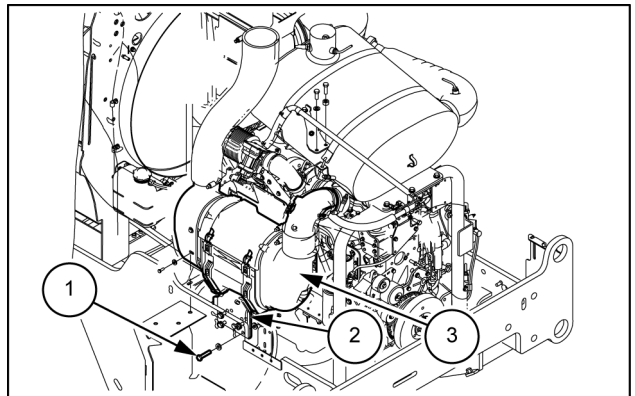

LEIL15WHL0037AB 30

31. Remove the four mounting bolts from the belt cover. Then remove the cover.

NOTE: after removing the belt cover, remove the cover mounting bracket from the left rear side of machine frame.

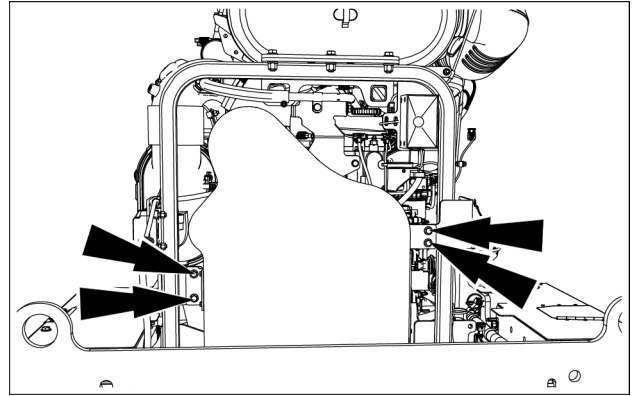

LEIL16WHL0566AB 31

32. Remove the drive belt from the engine.

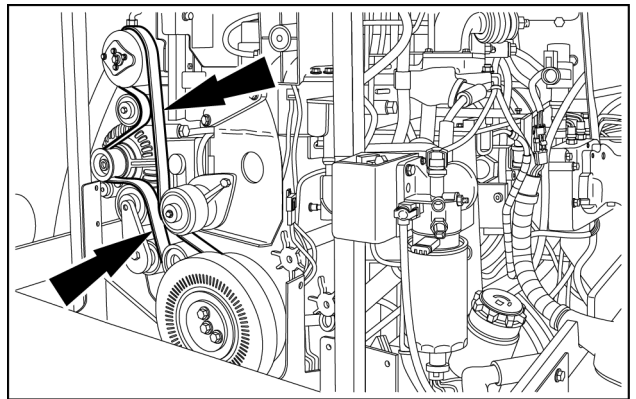

LEIL13WHL0155AB 32

33. If machine is equipped with the air conditioning system, identify, tag, and disconnect the engine wiring harness connectors from the air compressor clutch connector (1) and high pressure switch (2). Then remove the three mounting bolts (3) for the compressor and carefully set it on the left battery cover.

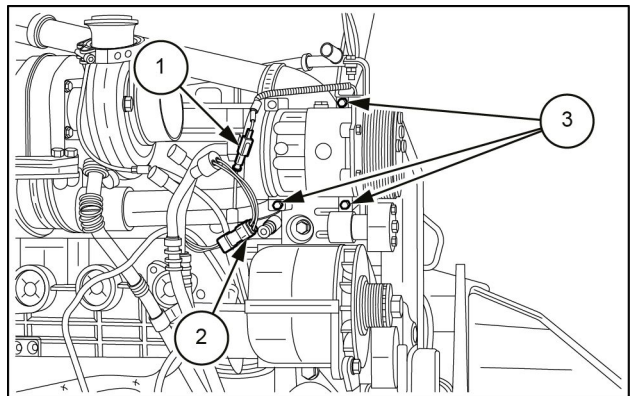

LEIL13WHL0156AB 33

34. Tag and disconnect the wiring from the alternator.

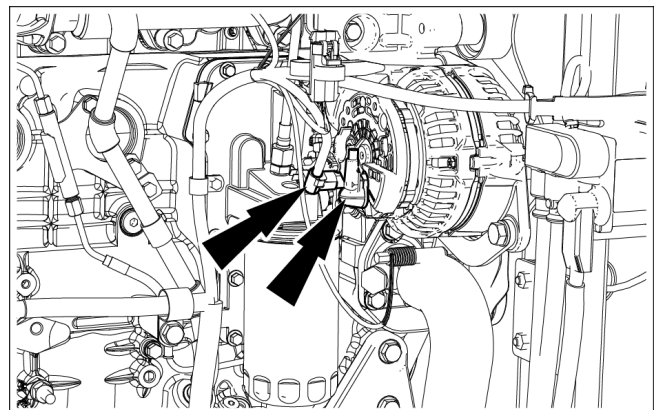

LEIL16WHL0693AB 34

35. Remove the return line of the SCR coolant.

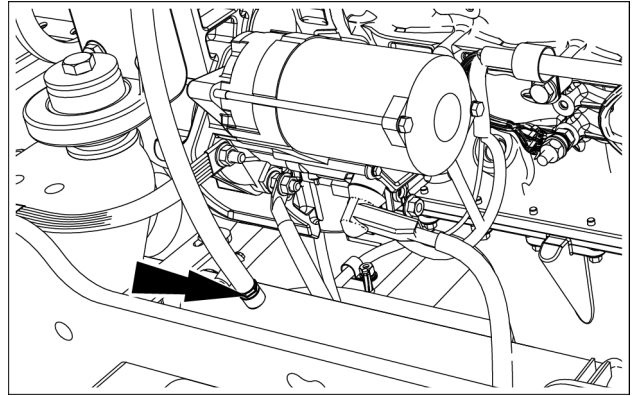

LEIL16WHL0568AB 35

36. Tag and remove the wires from the starter solenoid (1), the ground cable (2), and ground strap (3) from the starter.

NOTE: move the starter cables away from the engine.

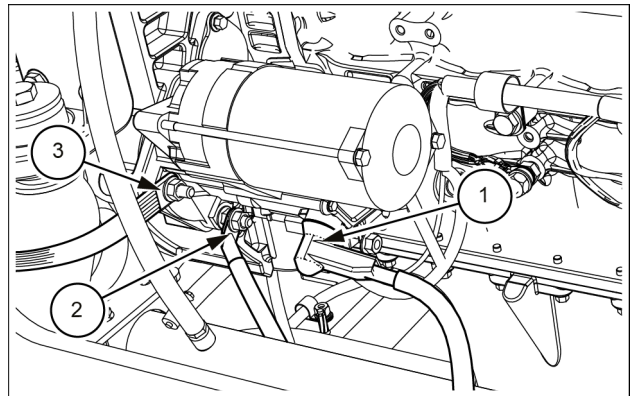

LEIL16WHL0569AB 36

37. Remove the bolts securing the wiring harness clamps to the engine.

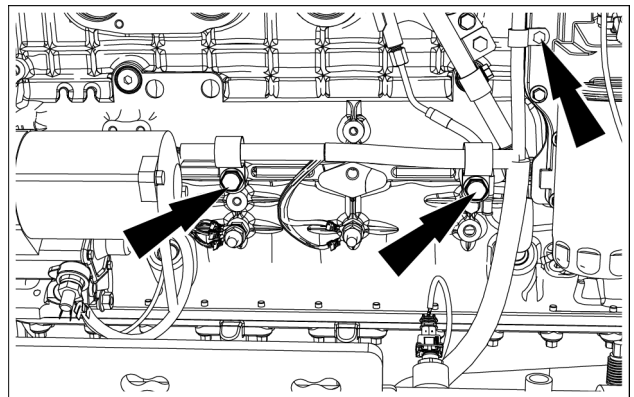

LEIL16WHL0570AB 37

38. Remove the ground wires from the engine.

NOTE: move the wiring harness away from the engine.

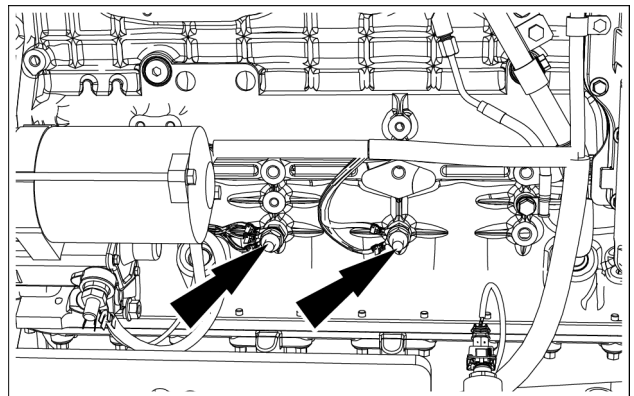

LEIL16WHL0572AB 38

39. If the machine is so equipped, unplug the engine block heater and set it aside.

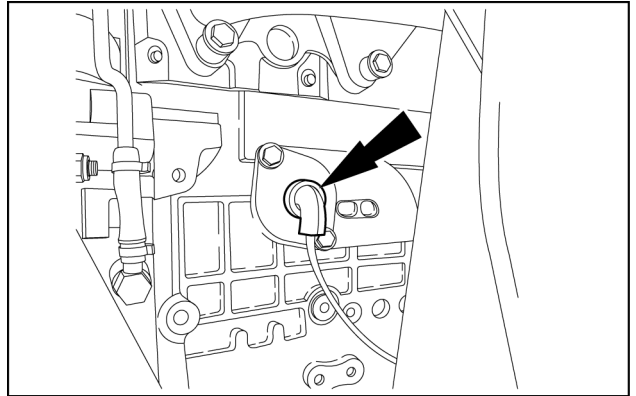

LEIL15WHL0016AB 39

40. Loosen the clamp (see the arrow in figure) and disconnect the pipe.

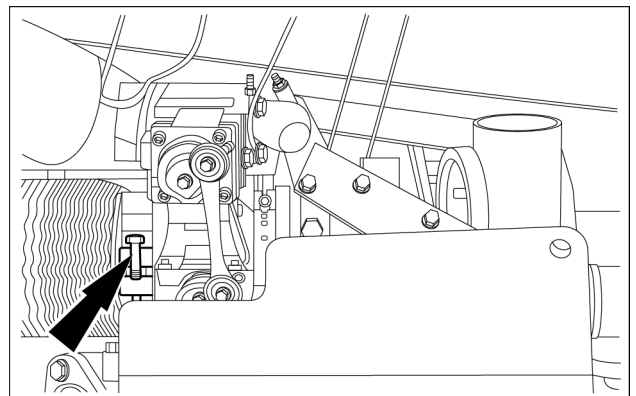

LEIL15WHL0015AB 40

41. Loosen the clamps and remove the lower coolant hose from the engine.

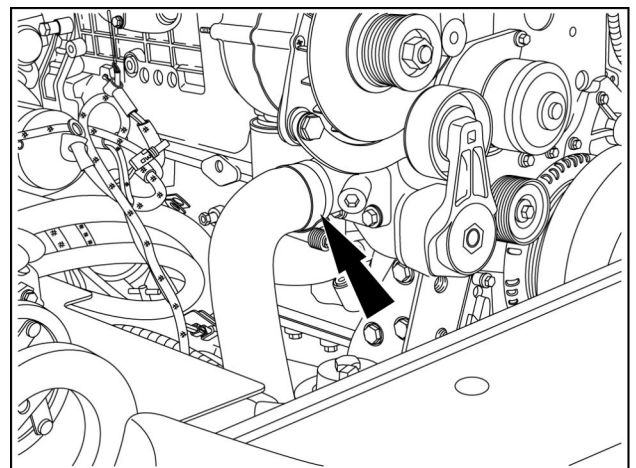

RAPH12WEL0629AA 41

42. Remove the radiator hose from the engine.

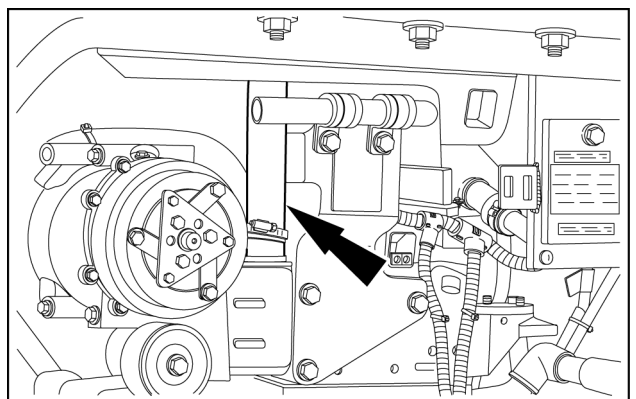

LEIL13WHL0159AB 42

43. Remove the return radiator hose (1) and the engine coolant vent hose from the top of the radiator.

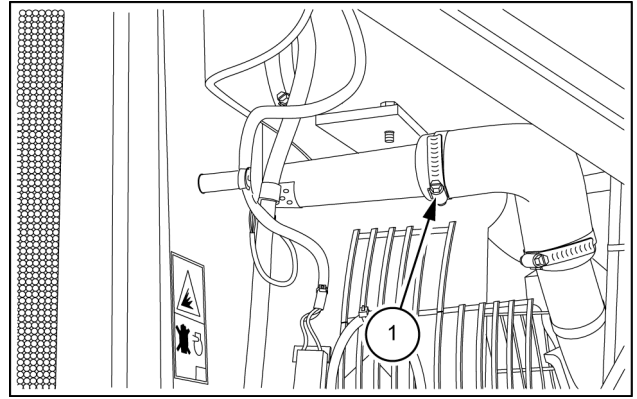

LEIL13WHL0141AB 43

44. Remove the overflow tank of the engine coolant.

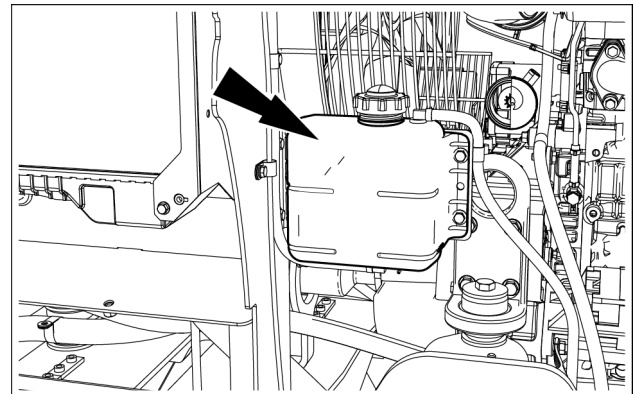

LEIL16WHL0574AB 44

45. Remove the bracket of the overflow tank.

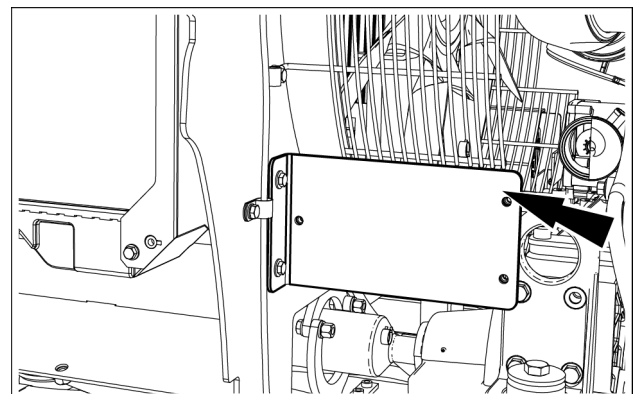

LEIL16WHL0575AB 45

46. Remove the cooling fan guard.

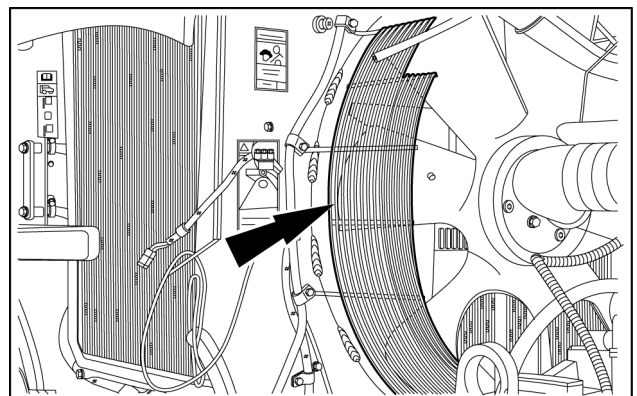

LEIL13WHL0160AB 46

47. Loosen the clamp **(1)** on the intake manifold for the output hose of the after cooler. Loosen the clamp **(2)** from the body of the DEF/AdBlue® tank vent filter.

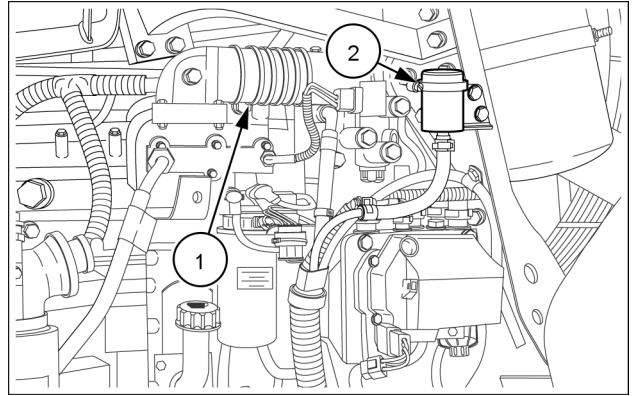

LEIL13WHL0613AA 47

48. Loosen the clamp on the after cooler, and remove the output hose of the after cooler from the machine.

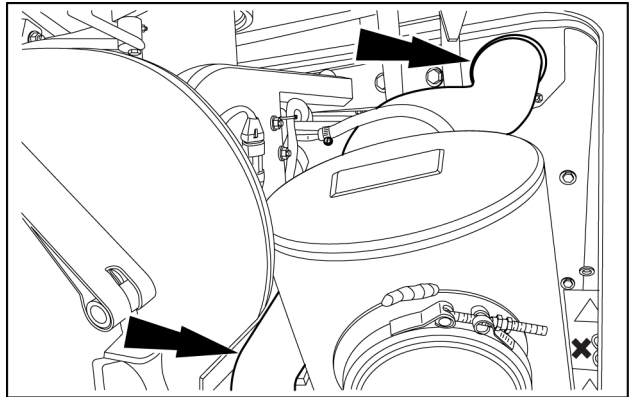

LEIL13WHL0162AB 48

49. Tag and disconnect the fuel filter heater wire **(1)** and the water sensor **(2)**. Then drain fuel filter and disconnect the inlet **(3)** and outlet **(4)** fuel lines from the fuel filter head. Plug the lines and cap the fittings. Remove the ground wire and the attachment bolt **(5)** of the fuel filter head.

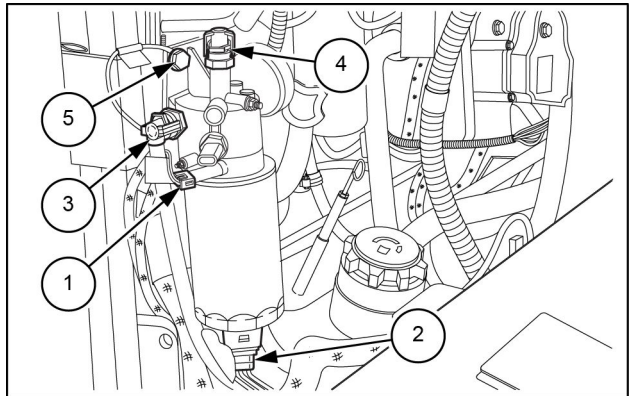

LEIL13WHL0163AB 49

50. Tag and remove the grid heater cable **(1)**.

NOTE: hold the rear nut with a second wrench to prevent grid heater damage.

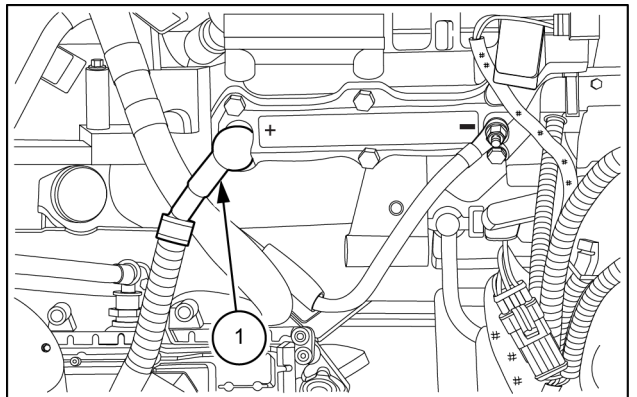

LEIL13WHL0164AB 50

51. Remove wire harness support clamp.

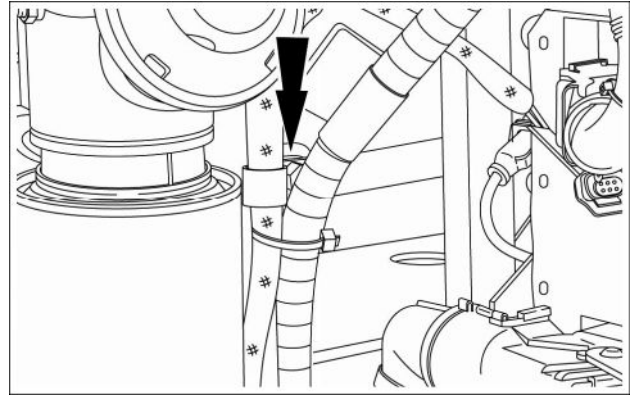

LEIL16WHL0490AB 51

52. Remove the P-clamp and cut the cable ties by the supply module. Disconnect the end of the jumper harness (near the supply module) from the Diesel Oxidation Catalyst (DOC) support.

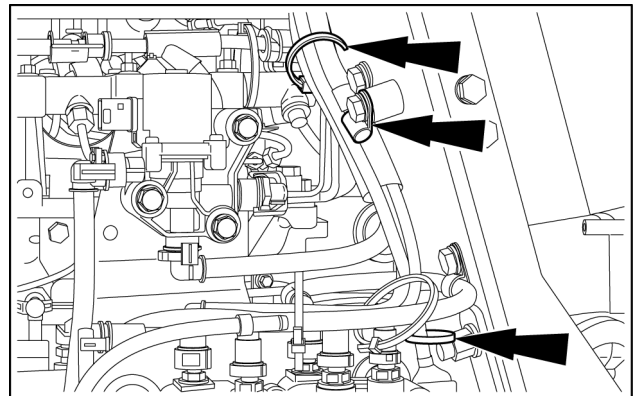

LEIL15WHL0034AB 52

53. Loosen the clamp (1) on the Diesel Oxidation Catalyst (DOC).

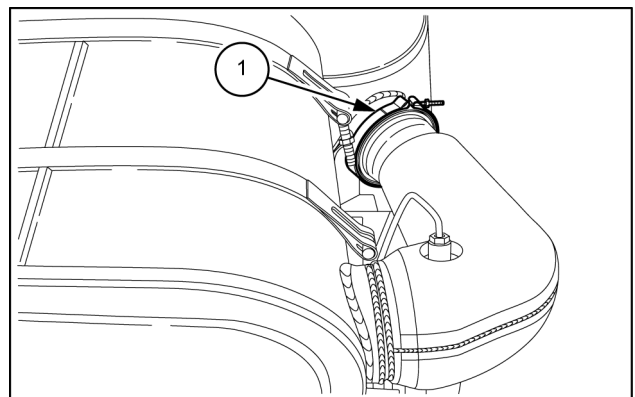

LEIL13WHL0166AB 53

54. Tag and disconnect the connector (1).

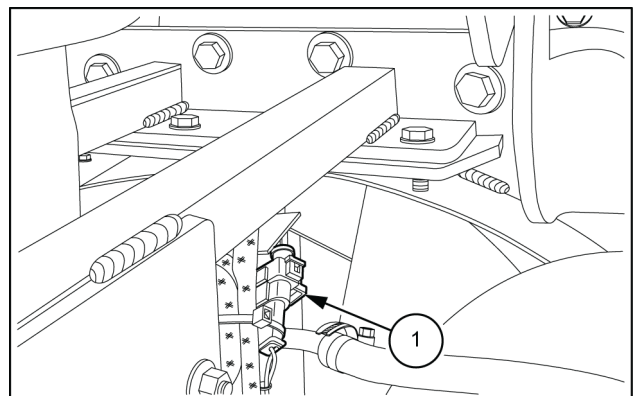

LEIL13WHL0167AB 54

55. Tag and disconnect the wire harness of the temperature sensor (1) for the Selective Catalytic Reduction muffler (SCR) and cut the connector wire clamps. Loosen the screws and remove the bar (2).

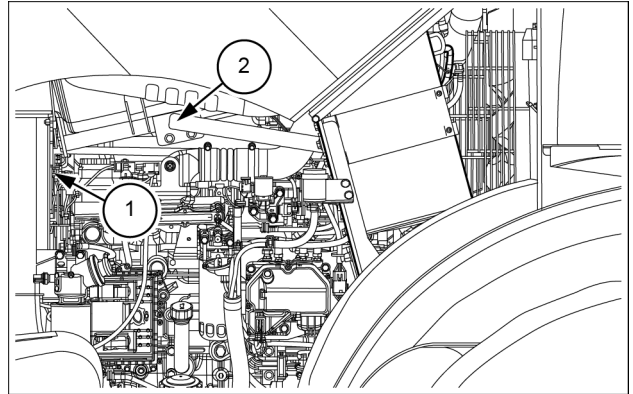

LEIL14WHL0407AB 55

56. Attach a suitable lifting straps to the Selective Catalytic Reduction muffler (SCR) support structure. Remove the bolts securing the support structure at the front (1) and rear (2) part of the structure. Use a suitable lifting device and carefully lift the support structure of the Selective Catalytic Reduction muffler (SCR) from the machine.

NOTE: pay particular attention to the connection between the SCR muffler and the Diesel Oxidation Catalyst (DOC).

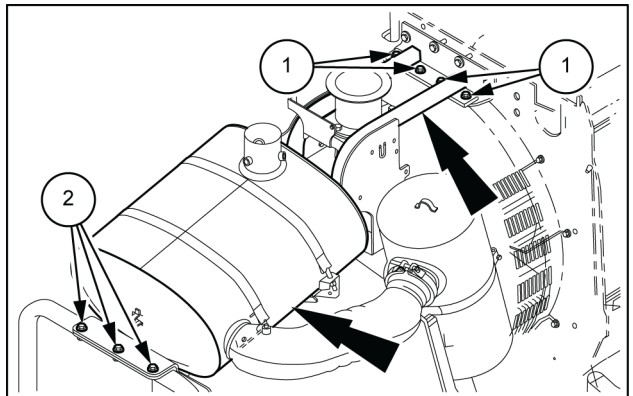

LEIL13WHL0169AB 56

57. Tag and disconnect the wire harness from the buzzer. Remove the bolts (1) securing the front support structure of the SCR muffler and remove it.

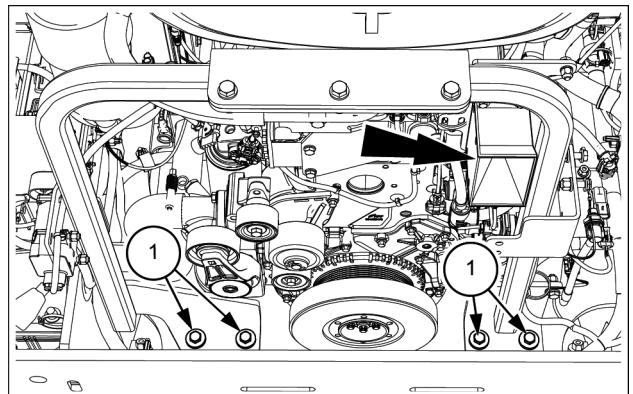

LEIL16WHL0567AB 57

58. Tag and disconnect wire harness from primary fuel filter.

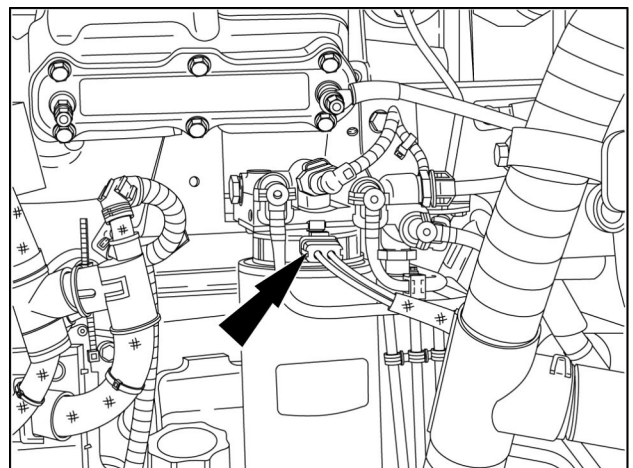

RAPH12WEL0068AA 58

59. Remove the **DEF/AdBLUE®** storage tank cover located on the right-hand side of the machine.

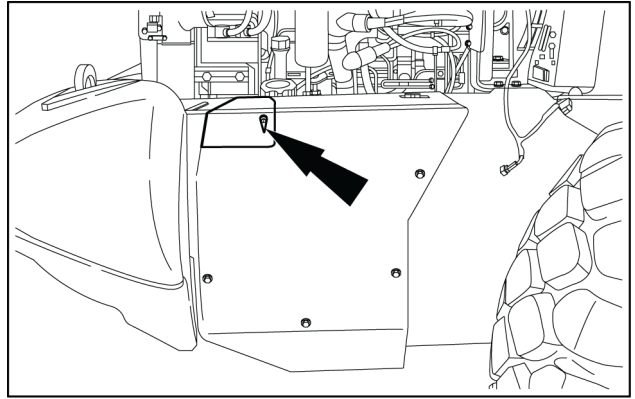

LEIL13WHL0170AB 59

60. Tag and disconnect the wire harness and **DEF/AdBLUE®** supply and return lines from the **DEF/AdBLUE®** storage tank. Install a protective cap in the supply lines.

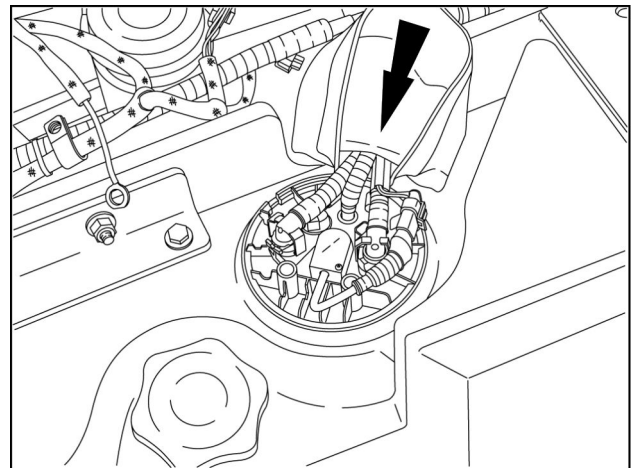

RAPH12WEL0070AA 60

61. Remove the support bracket of the hood lift cylinder.

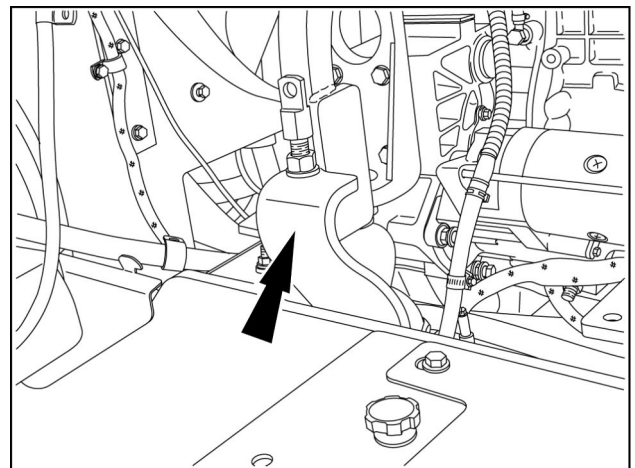

RAPH12WEL0071AA 61

62. Remove the heater hose from the engine.

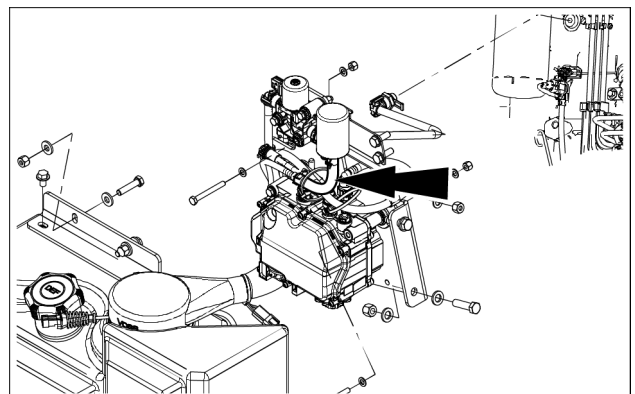

LEIL15WHL0009AB 62



Suggest:

If the above button click is invalid.

Please download this document

first, and then click the above link

to download the complete manual.

Thank you so much for reading

63. Disconnect the main connector of the supply module.

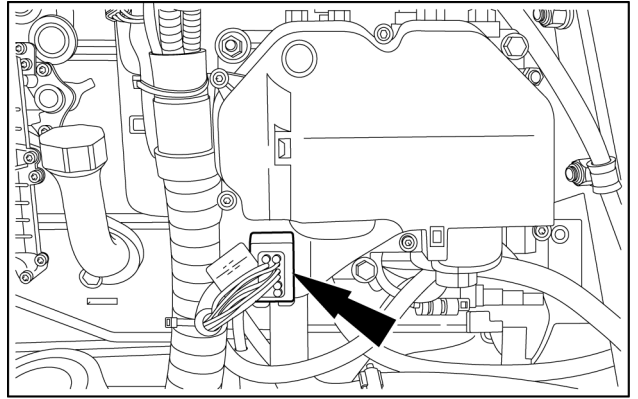

LEIL13WHL0171AB 63

64. Attach suitable lifting straps to the support structure (1) of the Diesel Oxidation Catalyst (DOC). The supply module and the coolant control valve are also attached to this support structure.

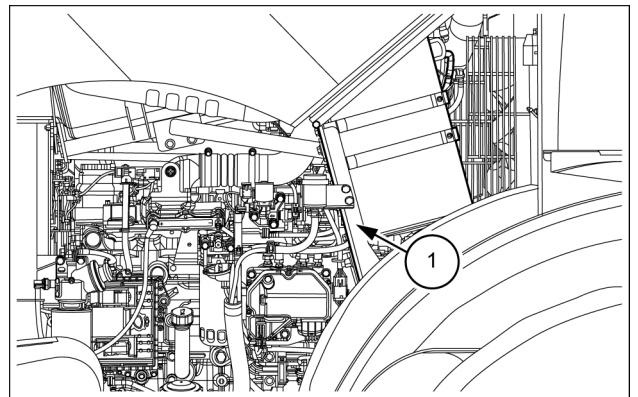

LEIL14WHL0212AB 64

65. Loosen the two hexagonal nuts of the sensors (3) and (4) and disconnect the sensors (3) and (4). Loosen the clamp (1) on the Diesel Oxidation Catalyst (DOC) and disconnect the exhaust pipe (2) from the Diesel Oxidation Catalyst (DOC).

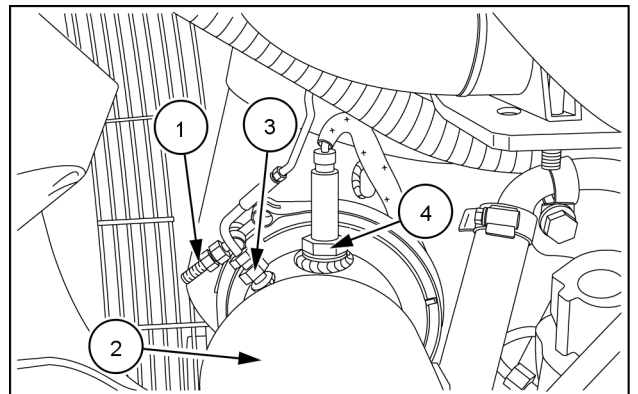

LEIL13WHL0229AA 65

66. Remove the SCR coolant supply line from the engine.

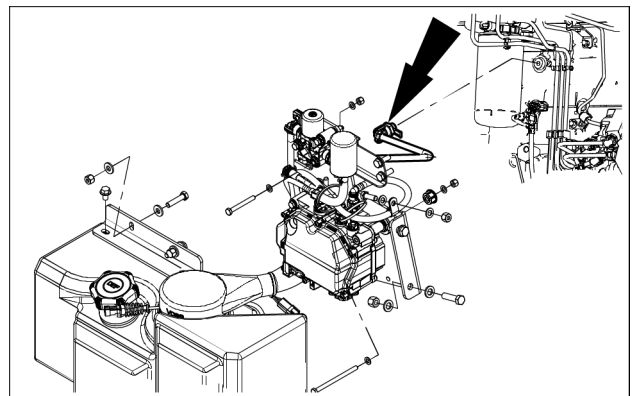

LEIL15WHL0008AB 66

<https://www.ebooklibonline.com>

Hello dear friend!

Thank you very much for reading.

Enter the link into your browser.

The full manual is available for immediate download.

<https://www.ebooklibonline.com>