

821F
921F
Stage IV
Wheel Loader

SERVICE MANUAL

Part number 47969425

English

November 2015

© 2015 CNH Industrial Italia S.p.A. All Rights Reserved.

CASE
CONSTRUCTION



SERVICE MANUAL

**821F XR
821F ZBAR
921F XR
921F ZBAR**

Link Product / Engine

Product	Market Product	Engine
821F XR WHEEL LOADER TIER 4B	Europe	F4HFE613S*B004
821F ZBAR WHEEL LOADER TIER 4B	Europe	F4HFE613S*B004
921F XR WHEEL LOADER TIER 4B	Europe	F4HFE613R*B006
921F ZBAR WHEEL LOADER TIER 4B	Europe	F4HFE613R*B006

<https://www.ebooklibonline.com>

Hello dear friend!

Thank you very much for reading.

Enter the link into your browser.

The full manual is available for immediate download.

<https://www.ebooklibonline.com>

Contents

INTRODUCTION

Engine	10
[10.001] Engine and crankcase	10.1
[10.202] Air cleaners and lines	10.2
[10.500] Selective Catalytic Reduction (SCR) exhaust treatment	10.3
[10.400] Engine cooling system	10.4
[10.414] Fan and drive	10.5
[10.310] Aftercooler.....	10.6
[10.304] Engine lubrication system.....	10.7
Transmission	21
[21.113] Powershift transmission	21.1
[21.155] Powershift transmission internal components.....	21.2
[21.700] Torque converter	21.3
Four-Wheel Drive (4WD) system	23
[23.314] Drive shaft.....	23.1
Front axle system	25
[25.100] Powered front axle	25.1
[25.102] Front bevel gear set and differential	25.2
[25.108] Final drive hub, steering knuckles, and shafts	25.3
Rear axle system	27
[27.100] Powered rear axle.....	27.1
[27.106] Rear bevel gear set and differential	27.2
[27.120] Planetary and final drives	27.3
Brakes and controls	33
[33.202] Hydraulic service brakes	33.1
[33.110] Parking brake or parking lock	33.2

Hydraulic systems	35
[35.000] Hydraulic systems.....	35.1
[35.300] Reservoir, cooler, and filters.....	35.2
[35.106] Variable displacement pump	35.3
[35.357] Pilot system	35.4
[35.752] Hydraulic fan drive cooling system.....	35.5
[35.355] Hydraulic hand control	35.6
[35.724] Front loader hydraulic system control.....	35.7
[35.701] Front loader arm hydraulic system	35.8
[35.723] Front loader bucket hydraulic system	35.9
[35.734] Tool quick coupler hydraulic system	35.10
Frames and ballasting	39
[39.100] Frame	39.1
Steering	41
[41.101] Steering control	41.1
[41.200] Hydraulic control components.....	41.2
[41.216] Cylinders	41.3
[41.910] Auxiliary steering	41.4
Wheels	44
[44.511] Front wheels.....	44.1
[44.520] Rear wheels.....	44.2
Cab climate control	50
[50.200] Air conditioning.....	50.1
Electrical systems	55
[55.100] Harnesses and connectors.....	55.1
[55.301] Alternator.....	55.2
[55.302] Battery.....	55.3

[55.011] Fuel tank system	55.4
[55.988] Selective Catalytic Reduction (SCR) electrical system	55.5
[55.989] Exhaust Gas Recirculation (EGR) electrical system	55.6
[55.012] Engine cooling system	55.7
[55.519] Cab brake controls	55.8
[55.030] Service brake electrical system	55.9
[55.031] Parking brake electrical system	55.10
[55.512] Cab controls	55.11
[55.051] Cab Heating, Ventilation, and Air-Conditioning (HVAC) controls	55.12
[55.050] Heating, Ventilation, and Air-Conditioning (HVAC) control system	55.13
[55.047] Steering control system	55.14
[55.530] Camera	55.15
[55.518] Wiper and washer system	55.16
[55.514] Cab lighting	55.17
[55.408] Warning indicators, alarms, and instruments	55.18
[55.DTC] FAULT CODES	55.19
Front loader and bucket	82
[82.300] Bucket	82.1
Platform, cab, bodywork, and decals	90
[90.150] Cab	90.1
[90.156] Cab glazing	90.2
[90.114] Operator protections	90.3



INTRODUCTION

Safety rules

Personal safety





This is the safety alert symbol. It is used to alert you to potential personal injury hazards. Obey all safety messages that follow this symbol to avoid possible death or injury.

Throughout this manual you will find the signal words DANGER, WARNING, and CAUTION followed by special instructions. These precautions are intended for the personal safety of you and those working with you.

Read and understand all the safety messages in this manual before you operate or service the machine.

 DANGER indicates a hazardous situation that, if not avoided, will result in death or serious injury.

 WARNING indicates a hazardous situation that, if not avoided, could result in death or serious injury.

 CAUTION indicates a hazardous situation that, if not avoided, could result in minor or moderate injury.

FAILURE TO FOLLOW DANGER, WARNING, AND CAUTION MESSAGES COULD RESULT IN DEATH OR SERIOUS INJURY.

Machine safety

NOTICE: Notice indicates a situation that, if not avoided, could result in machine or property damage.

Throughout this manual you will find the signal word Notice followed by special instructions to prevent machine or property damage. The word Notice is used to address practices not related to personal safety.

Information

NOTE: Note indicates additional information that clarifies steps, procedures, or other information in this manual.

Throughout this manual you will find the word Note followed by additional information about a step, procedure, or other information in the manual. The word Note is not intended to address personal safety or property damage.

Personal safety

Carefully read this Manual before proceeding with maintenance, repairs, refuelling or other machine operations.

Repairs have to be carried out only by authorized and instructed staff; specific precautions have to be taken when grinding, welding or when using mallets or heavy hammers.

Non-authorized persons are not allowed to repair or carry out maintenance on this machine. Do not carry out any work on the equipment without prior authorization.

Ask your employer about the safety instructions in force and safety equipment.

Nobody should be allowed in the cab during machine maintenance unless he is a qualified operator helping with the maintenance work.

If it is necessary to move the equipment to carry out repairs or maintenance, do not lift or lower the equipment from any other position than the operator's seat.

Never carry out any operation on the machine when the engine is running, except when specifically indicated.

Stop the engine and ensure that all pressure is relieved from hydraulic circuits before removing caps, covers, valves, etc.

All repair and maintenance operations should be carried out with the greatest care and attention.

Service stairs and platforms used in a workshop or in the field should be built in compliance with the safety rules in force.

Any functional disorders, especially those affecting the safety of the machine, should therefore be rectified immediately.

⚠ DANGER

Unexpected movement!

Make sure parking brake is applied. Secure machine with wheel chocks.

Failure to comply will result in death or serious injury.

D0013A

Before performing any work on the machine, attach a maintenance in progress tag. This tag can be applied on the left-hand control lever, safety lever or cab door.

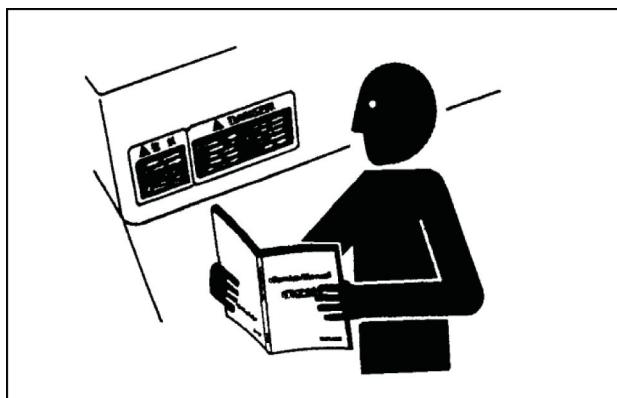

TULI12WEX2004AA 1

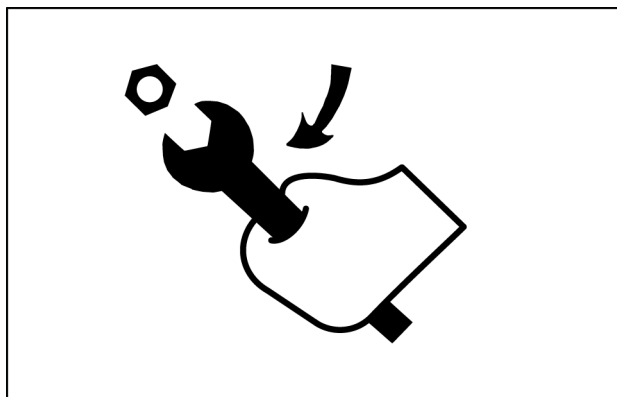

TULI12WEX2005AA 2

Product identification

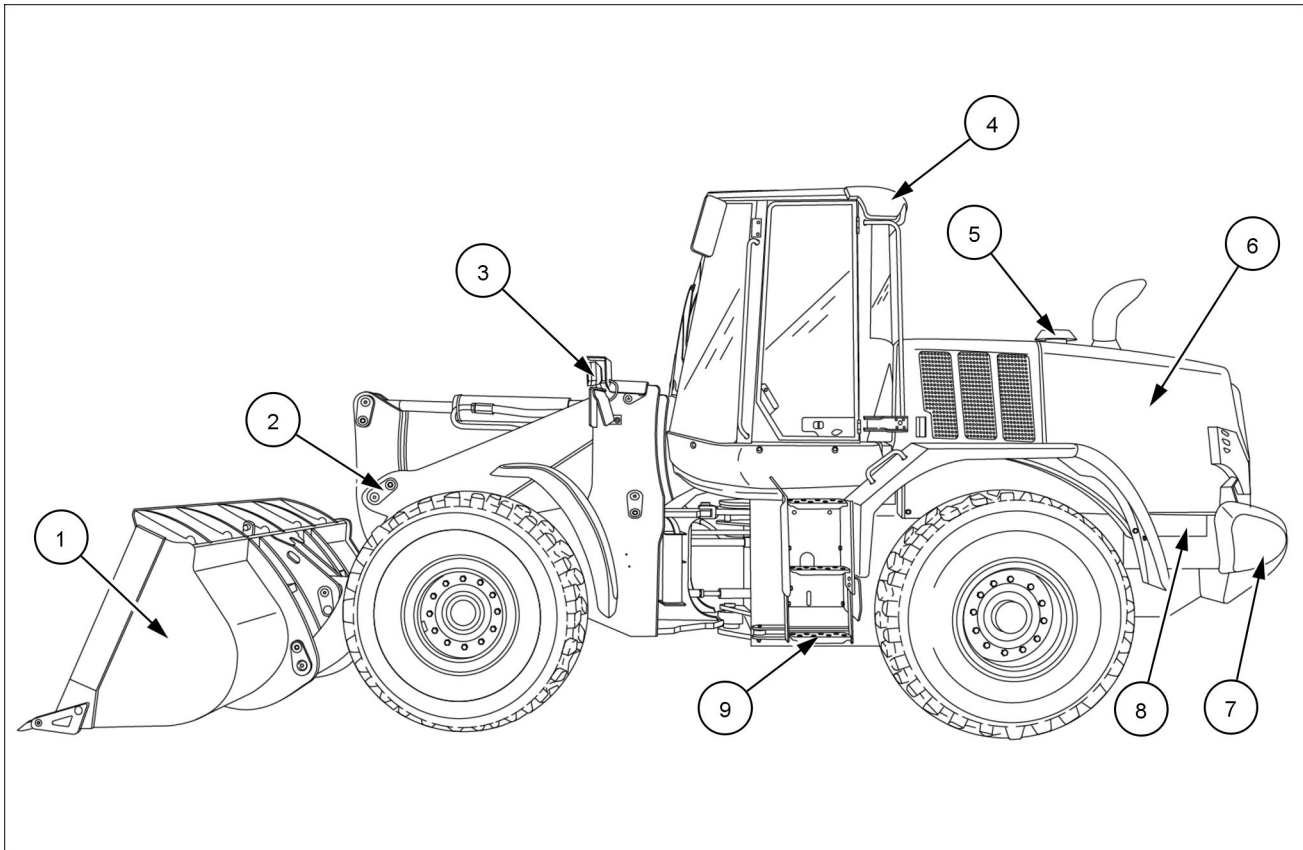

LEIL15WHL0056FA 1

- | | |
|---|--|
| 1. Bucket | 6. Engine and Selective Catalyst Reduction (SCR) system |
| 2. Loader lift arms (Z-bar version) | 7. Counterweight |
| 3. Driving lights | 8. Electric master switch and battery jump post (optional) |
| 4. Roll Over Protection System (ROPS) cab | 9. Steps |
| 5. Precleaner | |

INTRODUCTION

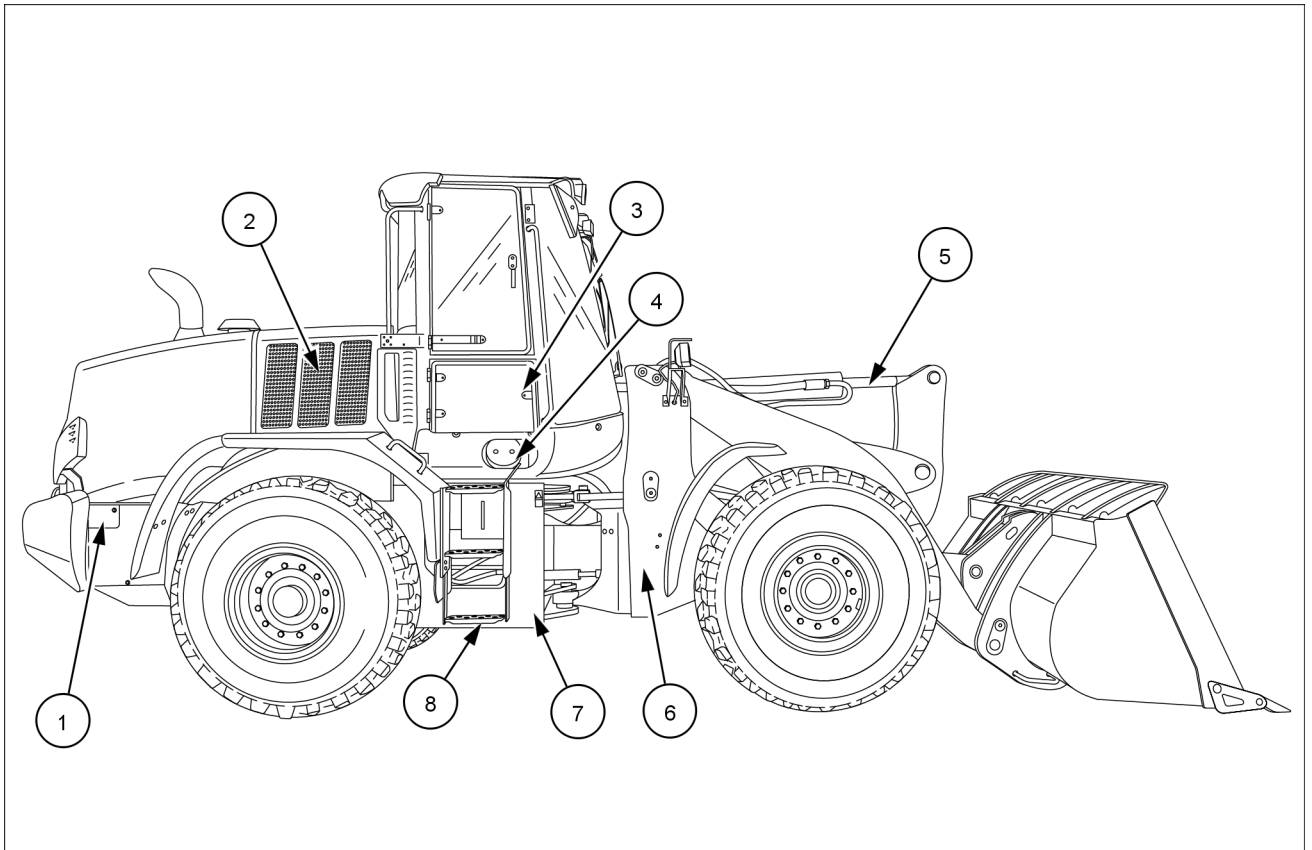

LEIL13WHL0214FA 2

- | | |
|---|--------------------|
| 1. Diesel Exhaust Fluid (DEF) fill tank | 5. Bucket cylinder |
| 2. Sliding access panel | 6. Front frame |
| 3. Fuse access door | 7. Rear frame |
| 4. Cab air filter | 8. Steps |



SERVICE MANUAL

Engine

**821F XR
821F ZBAR
921F XR
921F ZBAR**

Engine - General specification

Engine with 4 Speed Transmission	
A. Low idle	870 RPM to 930 RPM
Alternate low idle	670 RPM to 730 RPM
Alternate Accelerated Idle	1270 RPM to 1330 RPM
B. Maximum No Load RPM	2065 RPM to 2185 RPM
C. Converter Stall	1855 RPM to 2055 RPM
D. Hydraulic Stall	2065 RPM to 2265 RPM
E. Converter & Hydraulic Stall	1550 RPM to 1750 RPM
Temperature of the torque converter oil	82 - 104 °C (180 - 219 °F)
Temperature of the hydraulic oil	54 - 57 °C (129 - 135 °F)

Engine with 5 Speed Transmission	
A. Low idle	870 RPM to 930 RPM
Alternate low idle	670 RPM to 730 RPM
Alternate Accelerated Idle	1270 RPM to 1330 RPM
B. Maximum No Load RPM	2065 RPM to 2185 RPM
C. Converter Stall	1912 RPM to 2112 RPM
D. Hydraulic Stall	2070 RPM to 2270 RPM
E. Converter & Hydraulic Stall	1590 RPM to 1790 RPM
Temperature of the torque converter oil	82 - 104 °C (180 - 219 °F)
Temperature of the hydraulic oil	54 - 57 °C (129 - 135 °F)

NOTE: Hydraulic Stall and Converter & Hydraulic Stall RPM values are read while the lift arms are rising with the bucket held rolled back and the engine at Wide Open Throttle (WOT) in max power mode with transmission in manual mode and in 3rd gear.

Engine - General specification

Engine with 4 Speed Transmission	
A. Low idle	870 RPM to 930 RPM
Alternate low idle	670 RPM to 730 RPM
Alternate Accelerated Idle	1270 RPM to 1330 RPM
B. Maximum No Load RPM	2115 RPM to 2200 RPM
C. Converter Stall	1835 RPM to 2035 RPM
D. Hydraulic Stall	2075 RPM to 2275 RPM
E. Converter & Hydraulic Stall	1560 RPM to 1760 RPM
Temperature of the torque converter oil	82 - 104 °C (180 - 219 °F)
Temperature of the hydraulic oil	54 - 57 °C (129 - 135 °F)

Engine with 5 Speed Transmission	
A. Low idle	870 RPM to 930 RPM
Alternate low idle	670 RPM to 730 RPM
Alternate Accelerated Idle	2170 RPM to 1330 RPM
B. Maximum No Load RPM	2115 RPM to 2200 RPM
C. Converter Stall	1837 RPM to 2037 RPM
D. Hydraulic Stall	2127 RPM to 2327 RPM
E. Converter & Hydraulic Stall	1560 RPM to 1760 RPM
Temperature of the torque converter oil	82 - 104 °C (180 - 219 °F)
Temperature of the hydraulic oil	54 - 57 °C (129 - 135 °F)

NOTE: Hydraulic Stall and Converter & Hydraulic Stall RPM values are read while the lift arms are rising with the bucket held rolled back and the engine at Wide Open Throttle (WOT) in max power mode with transmission in manual mode and in 3rd gear.

Engine - General specification – Engine Service Manual

The table below lists the part numbers of the Engine FPT F4HFE613 Service Manual. The part numbers of the European languages related to this manual are reported. See the Engine Service Manual for more details about the engine overhaul.

Language	Engine Service Manual P/N
English	47606122
French	47606125
German	47606126
Italian	47606127
Spanish	47606130

Engine - Remove

NOTE: Emissions sensors mounted in the exhaust stream are sensitive to extreme vibrations. Use of tools that generate extreme vibrations, such as impact wrenches and hammers, will result in damage to emission sensors. Avoid using these tools during any service procedure in close proximity of emission sensors. If the use of these tools cannot be avoided, remove the sensors using extreme caution prior to performing any service procedure.

1. Park machine on a level surface and lower the bucket to the ground. Put articulation lock in LOCKED position and stop the engine.

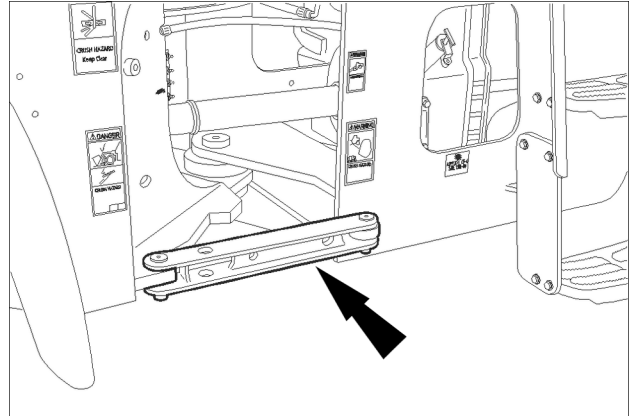

RCPH10WHL063BAL 1

2. Actuate the brake pedal several times to discharge brake accumulators.

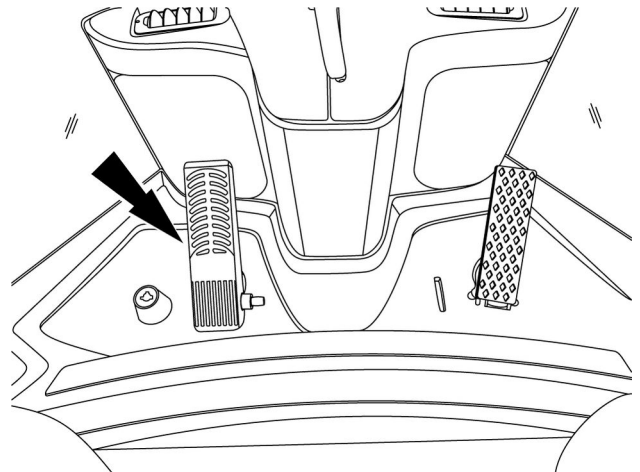

RCPH10WHL435AAH 2

3. Put key switch in ON position. Pilot control switch must be in the ON position and then move loader control lever(s) back and forth at least 30 times to release any pressure from hydraulic circuit. Put key switch in OFF position.

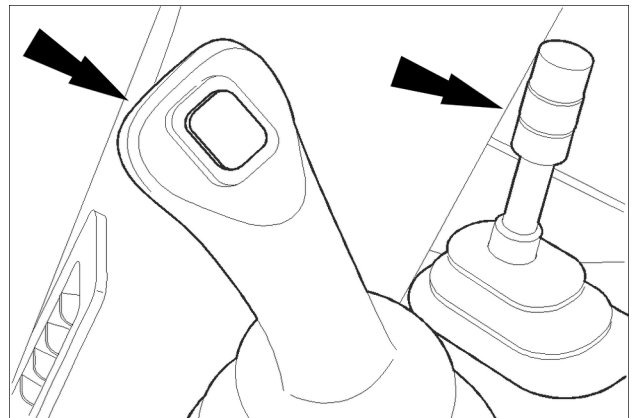

RCPH10WHL119BAL 3

4. Raise grill located above the cooler box just behind the cab. Then slowly loosen the hydraulic reservoir filler cap to release pressure in the reservoir.

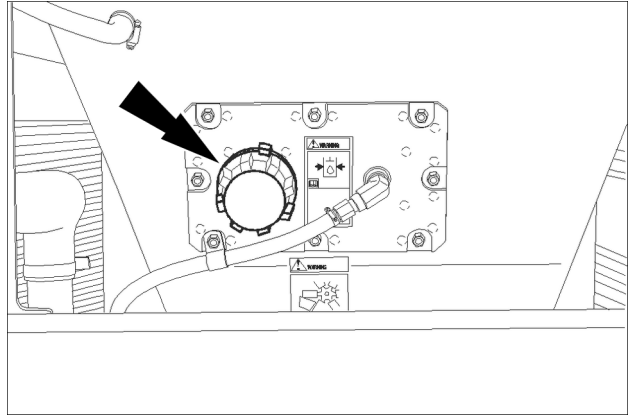

RCPH10WHL099BAL 4

5. Locate the master and hood raise switch by the battery box. Then raise the hood and put the master disconnect switch in the OFF position.

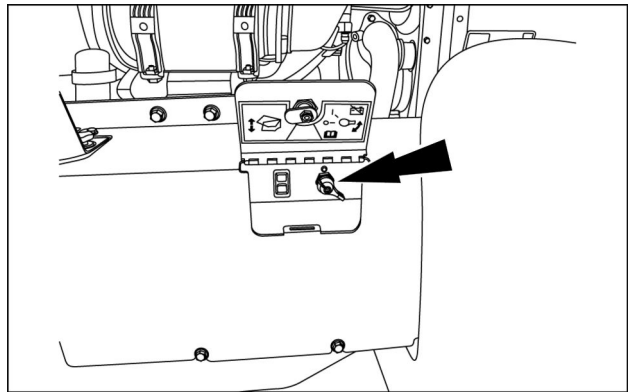

RCPH10WHL106AAH 5

6. Unhook the rubber T-handle (1) and raise the upper panel (2). Make sure that the security levers are blocked.

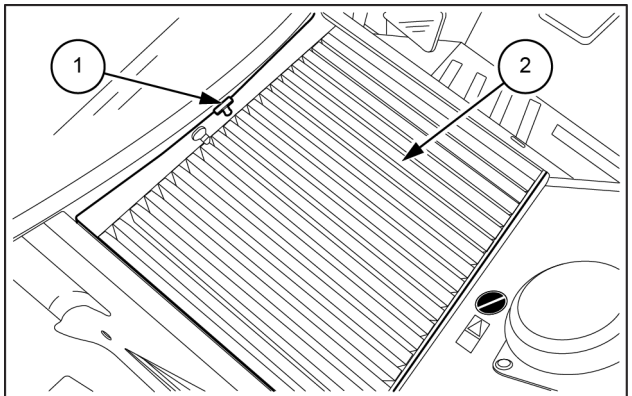

LEIL13WHL0137AB 6

7. Raise both side panels (1). Then remove the thumb screws (2) and inner fender panels (3).

NOTE: right-hand side of the machine is shown. The operation is similar for the left side.

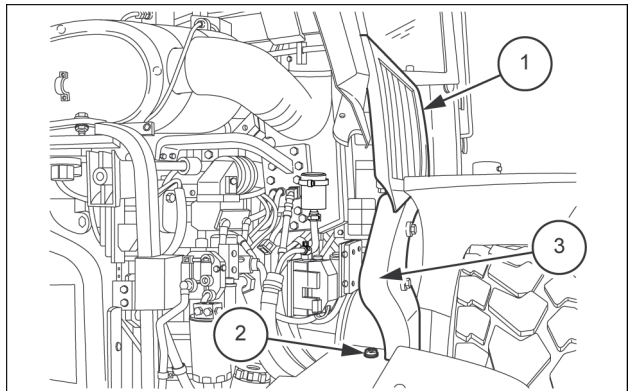

LEIL13WHL0612AB 7

8. Place a suitable container below radiator drain, remove radiator cap and coolant drain plug (arrow) to drain engine coolant. Then reinstall drain plug and radiator cap after coolant has drained.

NOTE: See machine specifications for cooling system volume.

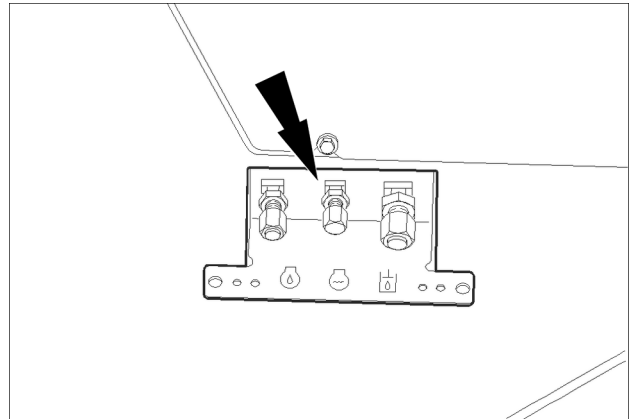

RCPH10WHL054BAL 8

9. Place a suitable container below engine oil drain. Remove drain plug and drain oil into container. Then reinstall drain plug.

NOTE: See machine specifications for engine oil sump volume.

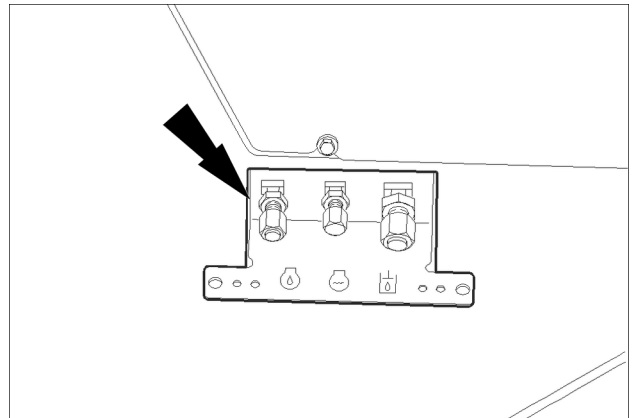

RCPH10WHL054BAL 9

10. After oil drains, disconnect drain hose from frame by removing jam nut (1). Then pull hose from frame in preparation for engine removal. (2)

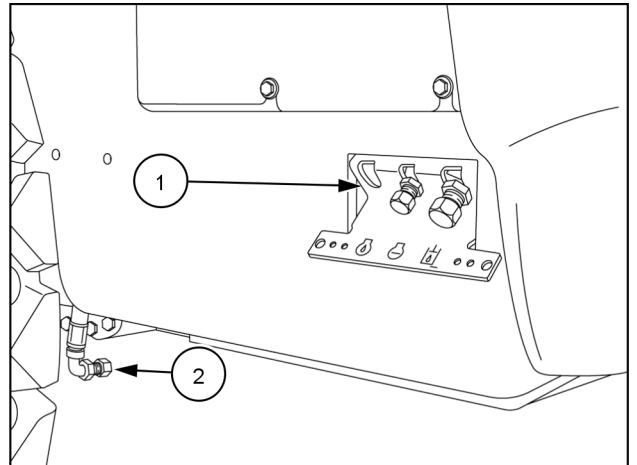

RAPH12WEL0598AA 10

11. Double up a nylon lifting strap and slide through the exhaust stack (1) on the hood.

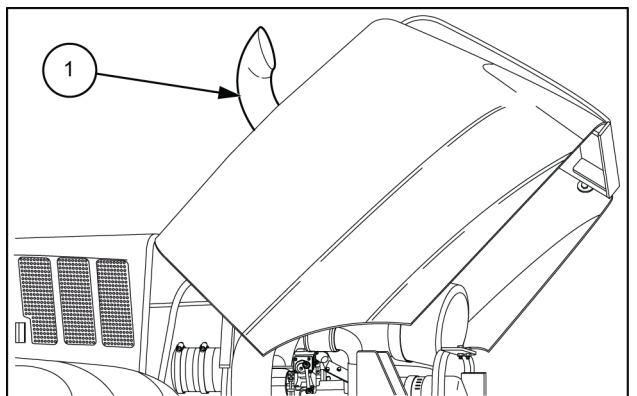

LEIL13WHL0552AB 11

12. Place a bar or pipe through the strap loop inside the hood and attach the strap to a suitable lifting device. Then raise the hood with the strap to release tension on the lifting motor.

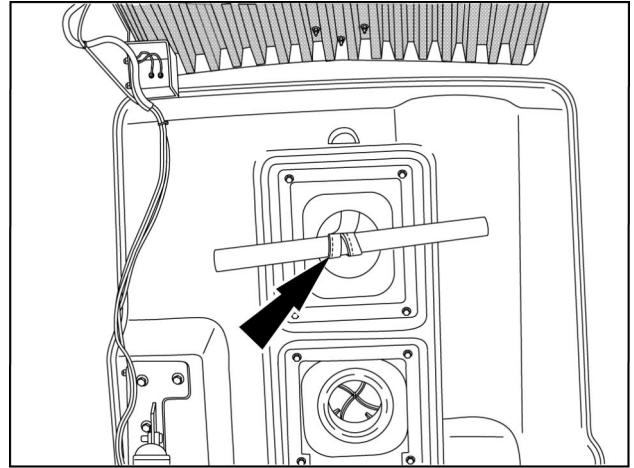

RAPH12WEL0600AA 12

13. Tag and disconnect the rearview camera wire harness (if machine is equipped with a rearview camera).

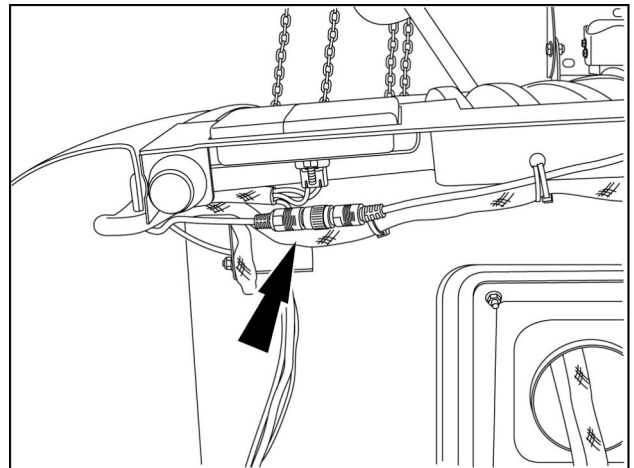

RAPH12WEL0601AA 13

14. Cut wire ties and remove rearview camera wire harness from hood. Then place it off to the side in a safe location. (If machine is equipped with a rearview camera.)

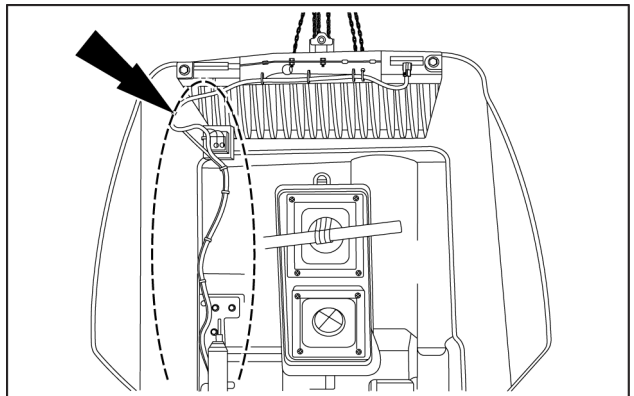

LEIL13WHL0140AB 14

15. Remove hood wire harness clamp (1) from the cooler housing. Then tag and remove the hood ground wire (2) from cooler housing.

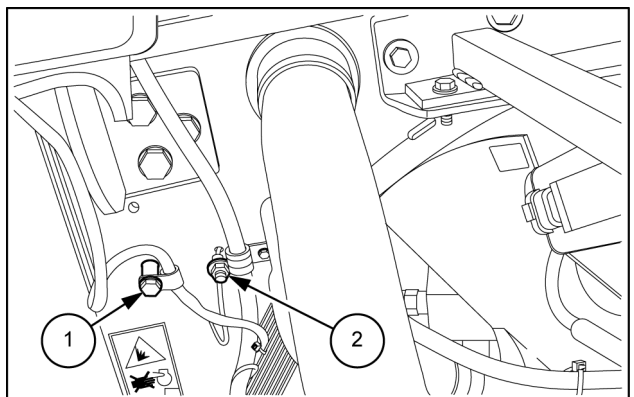

LEIL13WHL0149AB 15

16. Tag and disconnect hood wiring harness connector (1) from rear chassis wiring harness connector. Remove hood wire harness clamp (2) from the fan shroud.

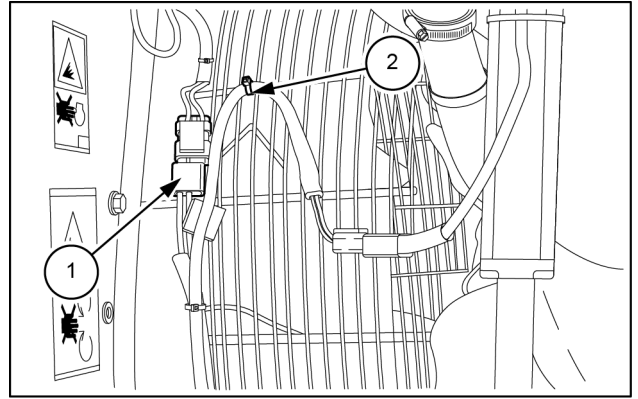

LEIL13WHL0150AB 16

17. Have another person to balance the hood and LOOSEN the hood hinge mounting bolts (arrows) from the cooler frame.

NOTE: Do not remove the hood hinge mounting bolts at this time.

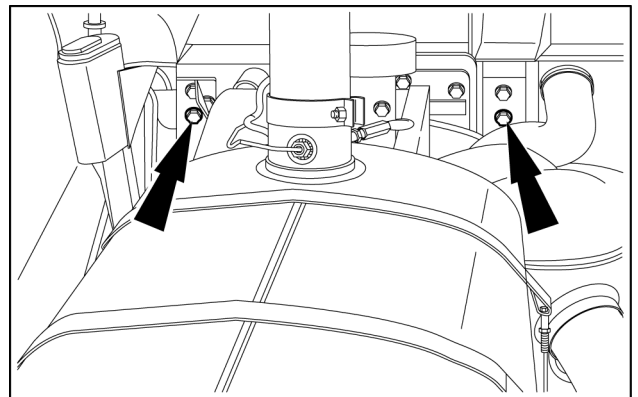

LEIL13WHL0142AB 17

18. Remove the pin from the bottom of the lifting motor cylinder where it attaches to the loader frame.

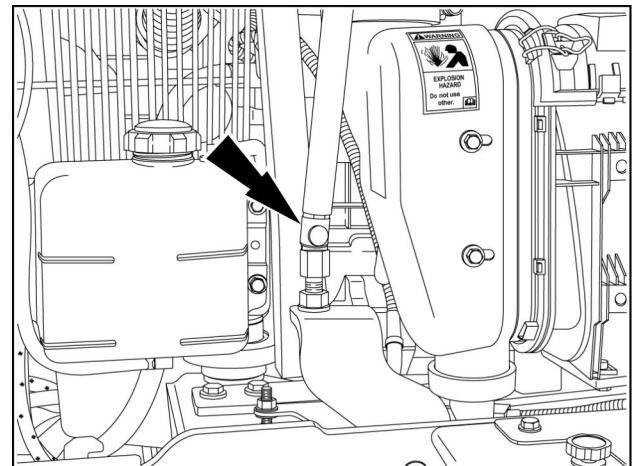

RAPH12WEL0606AA 18

19. Put the master disconnect switch in the ON position. Then, retract the lifting motor cylinder (2), replace pin and disconnect wiring harness (1).

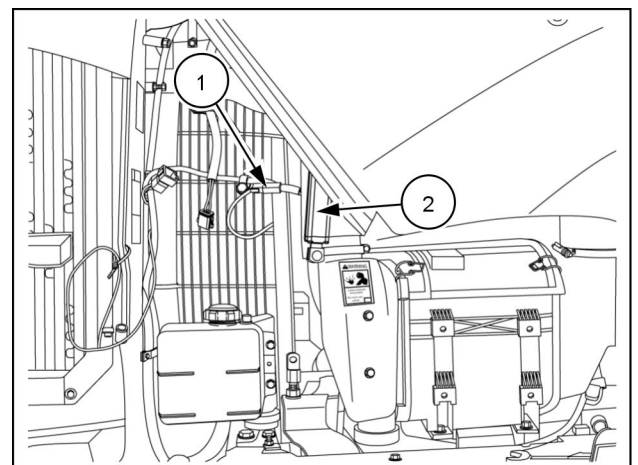

RAPH12WEL0606AA 19

20. Put master disconnect switch (1) in OFF position. Remove the battery cover and disconnect ground lead from the batteries (2). You may replace battery cover if desired to give you a place to stand.

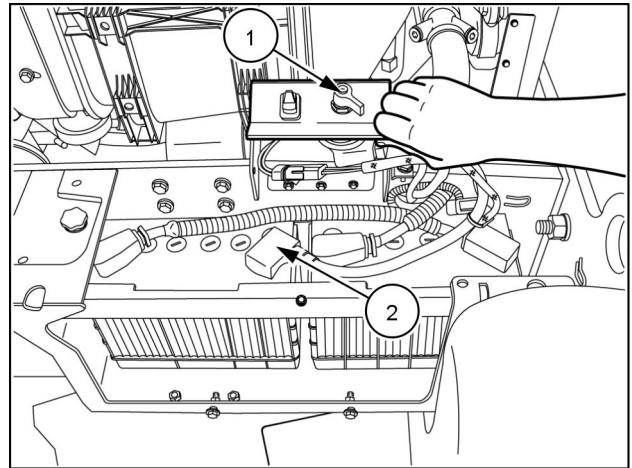

RAPH12WEL0608AA 20

21. Have another person to balance the hood and remove the hood hinge mounting bolts (arrows) from the cooler frame.

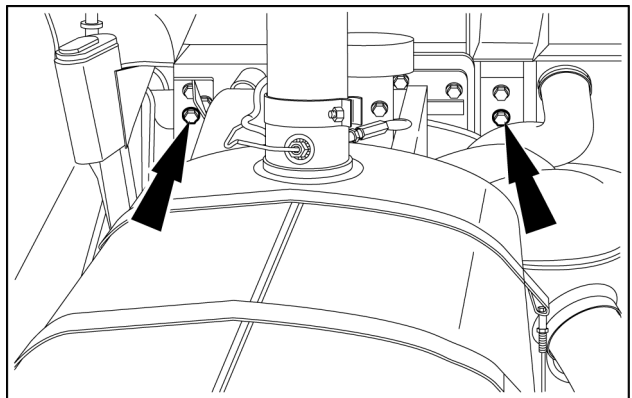

LEIL13WHL0142AB 21

22. Carefully raise and remove hood from loader. Lower hood onto suitable platform and disconnect lifting equipment from exhaust stack (1).

NOTE: Radiator overflow hose may interfere with left hand hood hinge movement and hood removal.

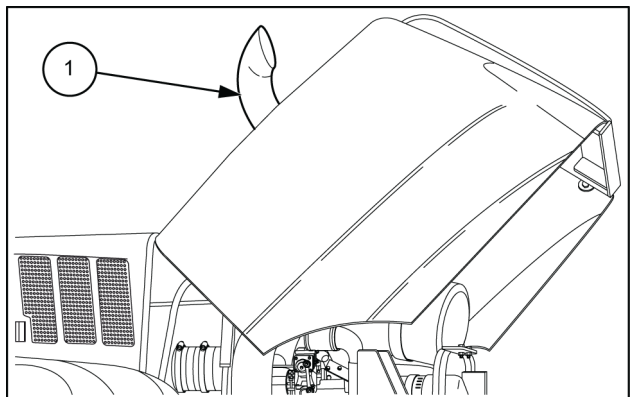

LEIL13WHL0552AB 22

23. Tag and disconnect engine wiring harness connector from air filter restriction switch.

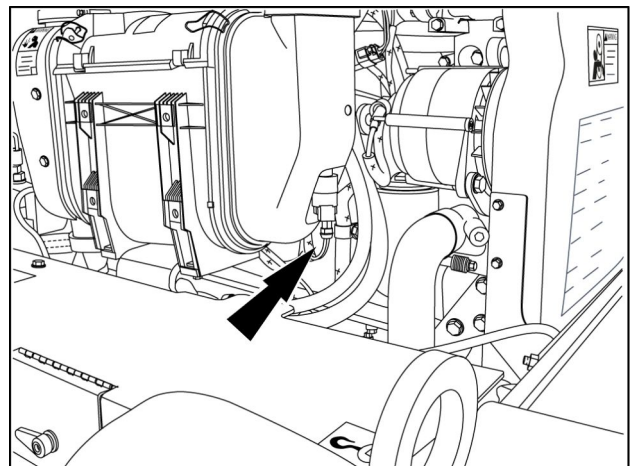

RAPH12WEL0610AA 23

24. Tag and disconnect engine wiring harness connector from air inlet humidity sensor (1).

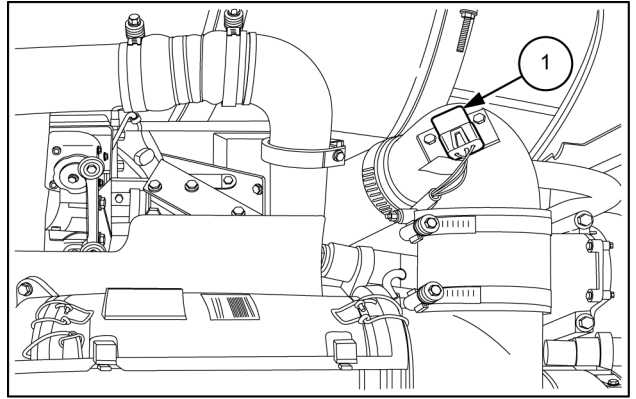

LEIL13WHL0143AB 24

25. Loosen clamp (1) on the crankcase ventilation hose (2) and disconnect hose.

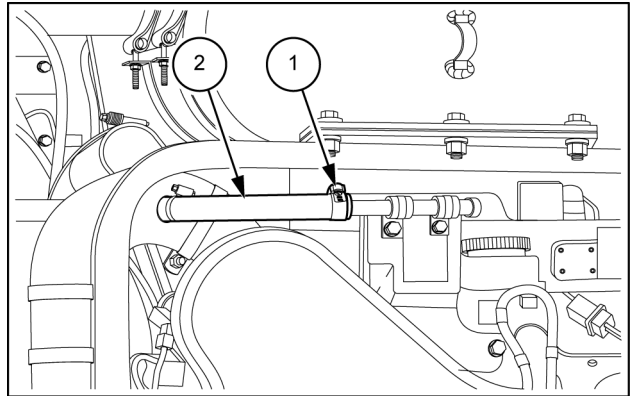

LEIL13WHL0144AB 25

26. Loosen clamps on turbocharger and air filter housing. Then remove the intake air hose (1). Cover turbocharger inlet to prevent debris entry.

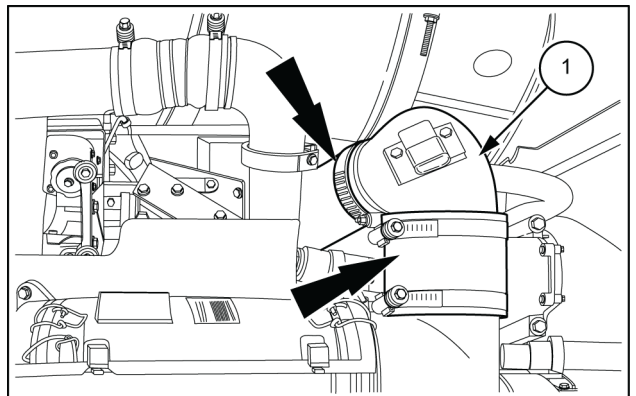

LEIL13WHL0145AB 26

27. Loosen the clamp from the elbow connected to the turbocharger.

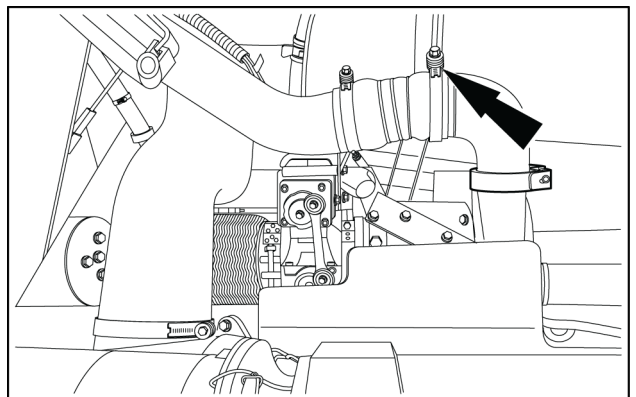

LEIL14WHL0203AB 27

28. Loosen the clamp on the hose at the after cooler inlet and remove the tube.

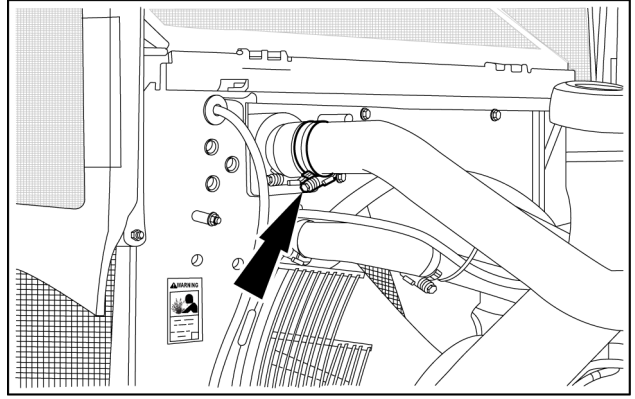

LEIL13WHL0147AB 28

29. Loosen clamp on the air inlet hose at the air filter housing.

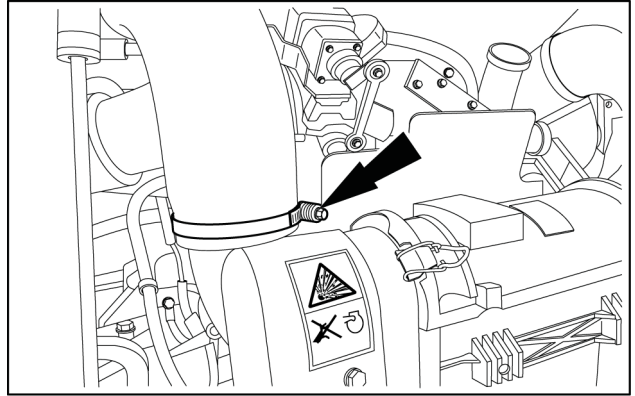

LEIL13WHL0148AB 29

30. Loosen the clamp (1) on the air inlet hose (2) at the exhaust support bracket. Remove the air inlet hose (2).

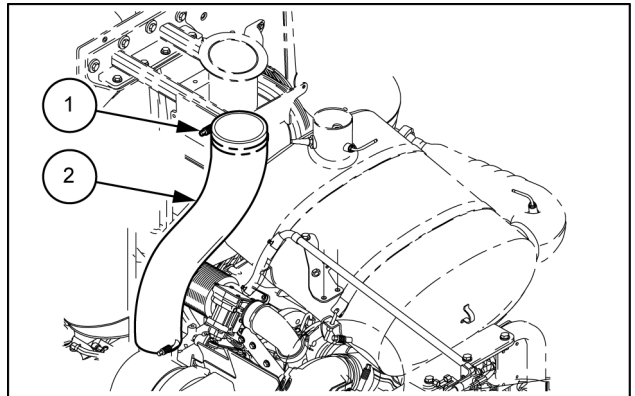

LEIL13WHL0151AB 30

31. Remove the four bolts securing the air filter housing to the mounting support bracket. Then remove the air filter housing.

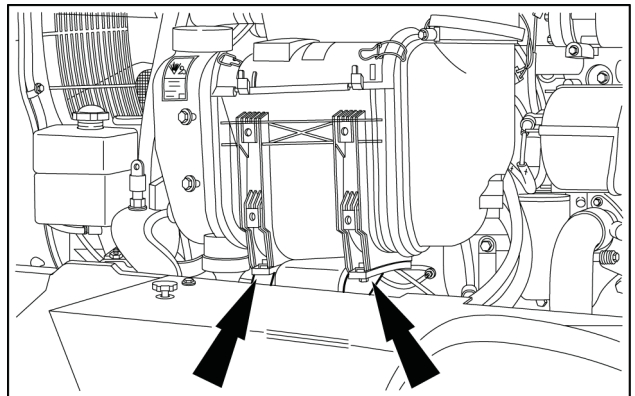

LEIL13WHL0153AB 31

32. Remove the four mounting bolts from the belt cover. Then remove the cover.

NOTE: After removing the belt cover, remove the cover mounting bracket from the left rear side of machine frame.

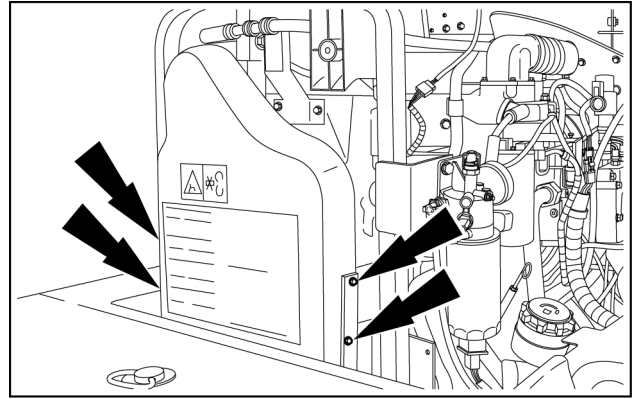

LEIL13WHL0154AB 32

33. Remove the drive belt from the engine.

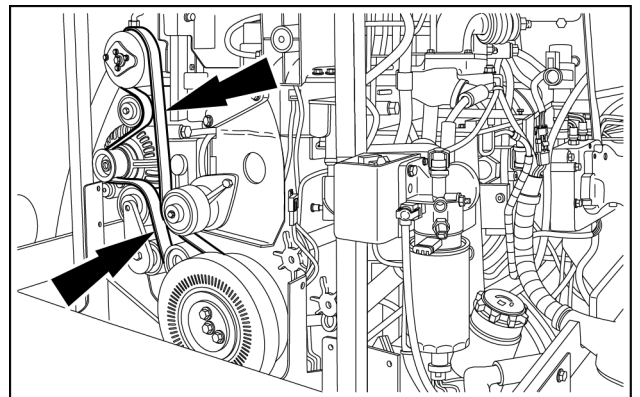

LEIL13WHL0155AB 33

34. If machine is equipped with the air conditioning system, identify, tag, and disconnect the engine wiring harness connectors from air compressor clutch connector (1) and high pressure switch (2). Then remove the three mounting bolts (3) for the compressor and carefully set it on the left battery cover.

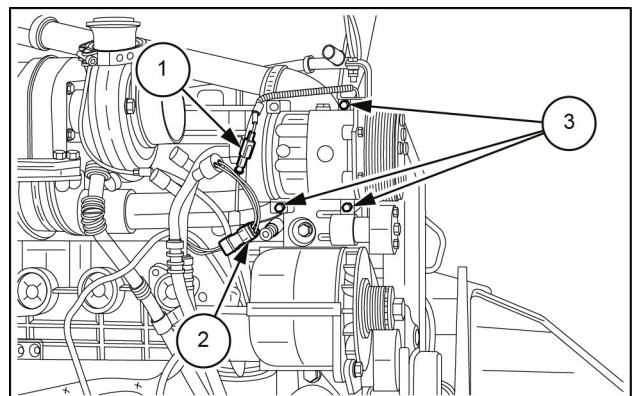

LEIL13WHL0156AB 34

35. Tag and disconnect the wiring from the alternator.

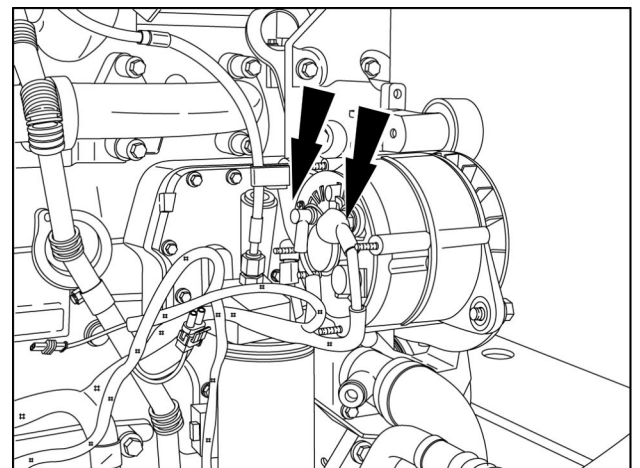

RAPH12WEL0622AA 35

36. Remove the return line of the SCR coolant.

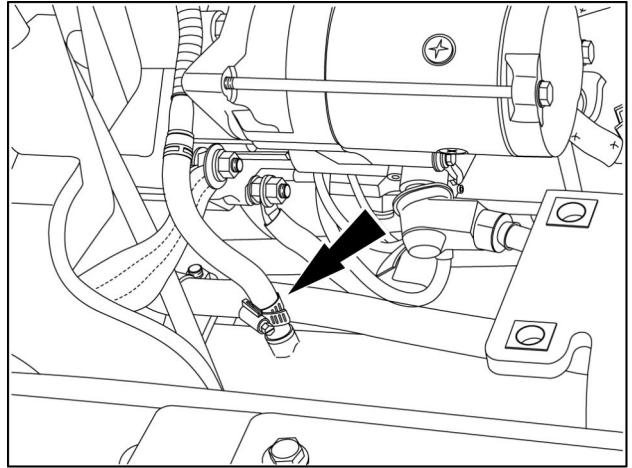

RAPH12WEL0623AA 36

37. Tag and remove the wires from the starter solenoid (1), the ground cable (2), and ground strap (3) from the starter.

NOTE: Move the starter cables away from the engine.

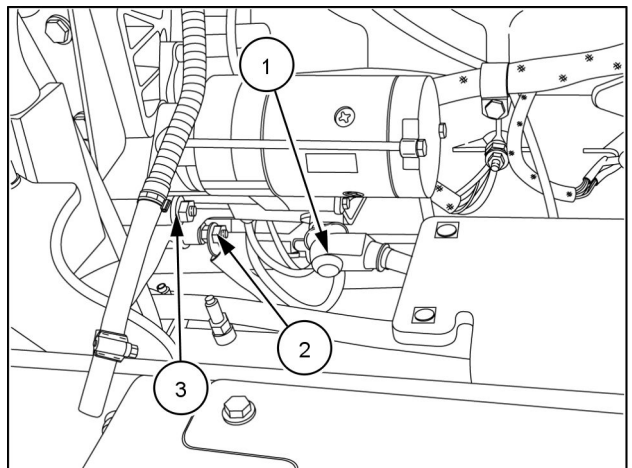

RAPH12WEL0624AA 37

38. Remove the bolts securing the wiring harness clamps to the engine.

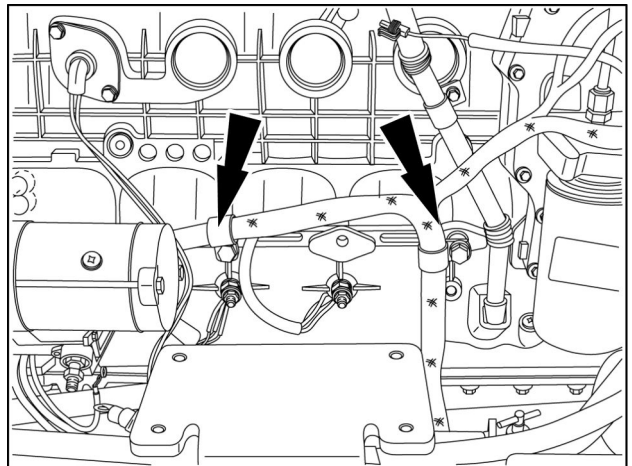

RAPH12WEL0625AA 38

39. Remove the ground wires from the engine.

NOTE: Move the wiring harness away from the engine.

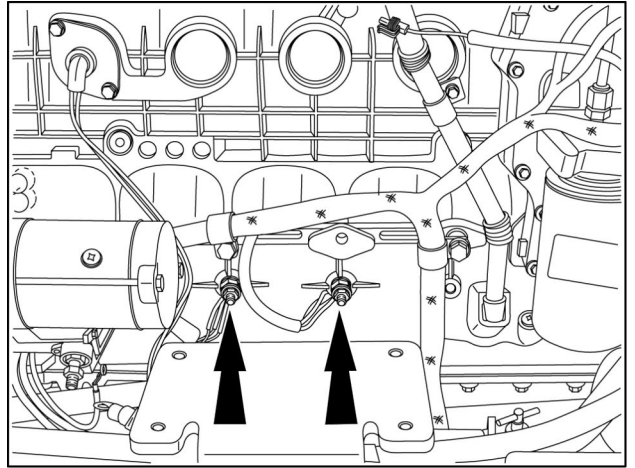

RAPH12WEL0625AA 39

40. If the machine is so equipped, unplug the engine block heater and set it aside.

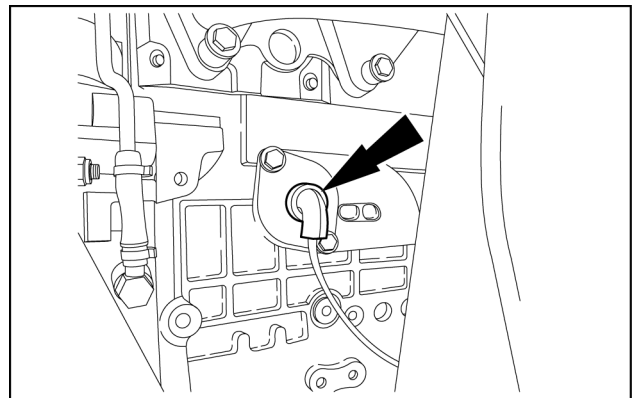

LEIL15WHL0016AB 40

41. Loosen the clamp (see the arrow in figure) and disconnect the pipe.

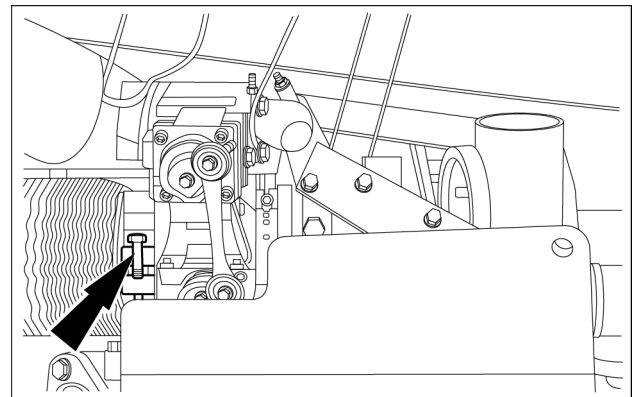

LEIL15WHL0015AB 41

42. Loosen the clamps and remove the lower coolant hose from the engine.

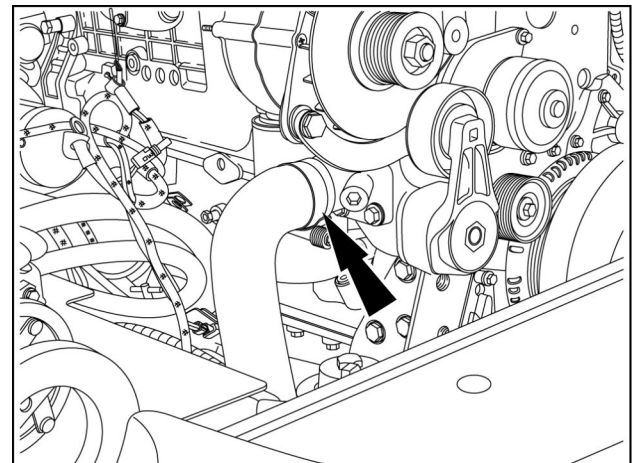

RAPH12WEL0629AA 42

43. Remove the radiator hose from the engine.

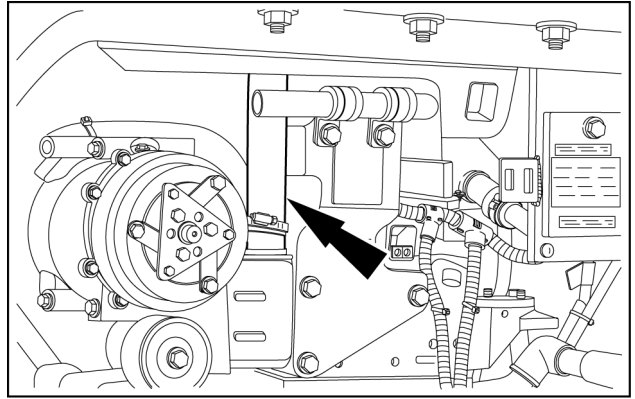

LEIL13WHL0159AB 43

44. Remove the return radiator hose (1) and the engine coolant vent hose from the top of the radiator.

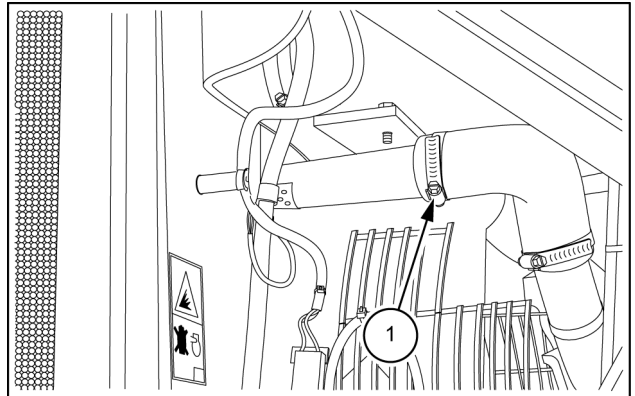

LEIL13WHL0141AB 44

45. Remove the overflow tank of the engine coolant.

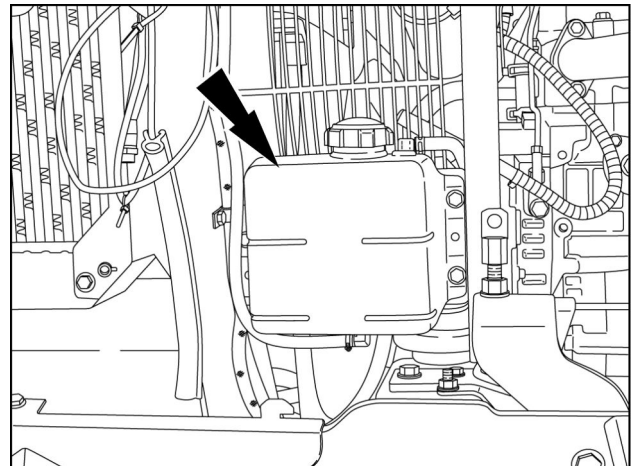

RAPH12WEL0633AA 45

46. Remove the bracket of the overflow tank.

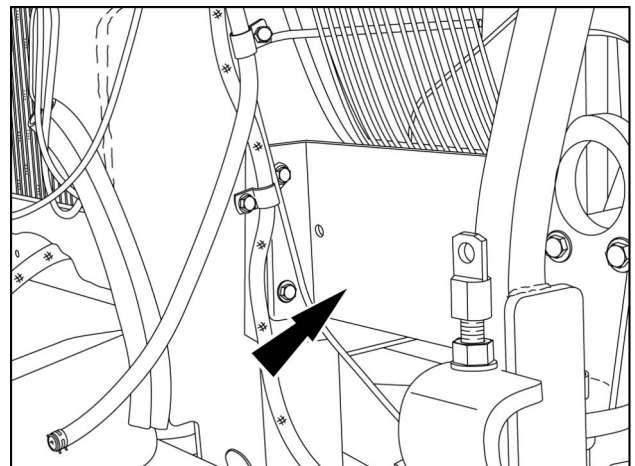

RAPH12WEL0634AA 46

47. Remove the cooling fan screen.

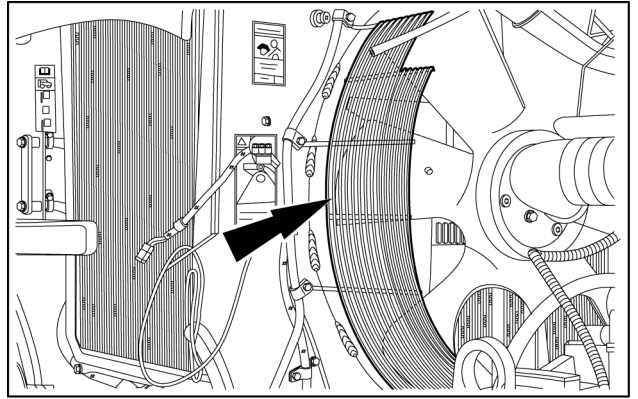

LEIL13WHL0160AB 47

48. Loosen the clamp **(1)** on the intake manifold for the output hose of the after cooler. Loosen the clamp **(2)** from the body of the DEF/AdBlue® tank vent filter.

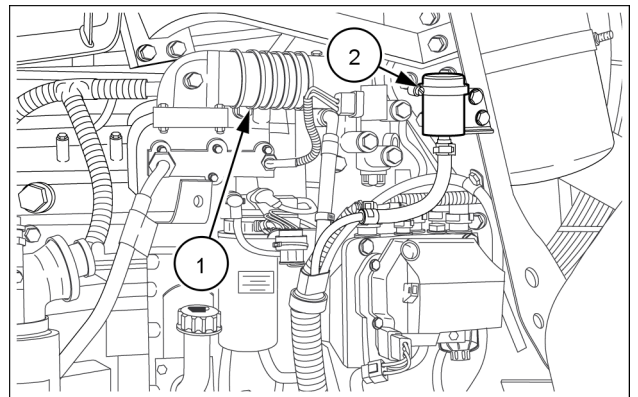

LEIL13WHL0613AA 48

49. Loosen the clamp on the after cooler, and remove the output hose of the after cooler from the machine.

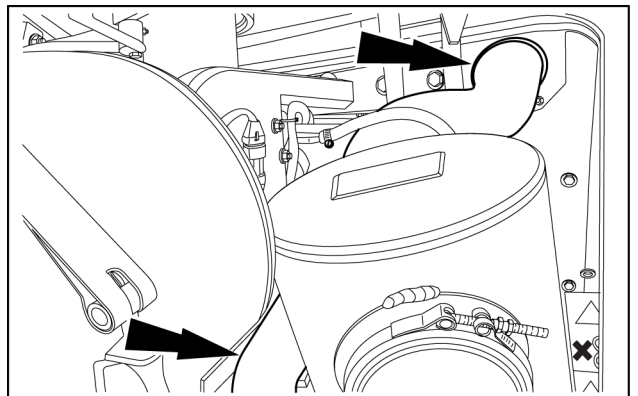

LEIL13WHL0162AB 49

50. Tag and disconnect the fuel filter heater wire **(1)** and the water sensor **(2)**. Then drain fuel filter and disconnect the inlet **(3)** and outlet **(4)** fuel lines from the fuel filter head. Plug the lines and cap the fittings. Remove the ground wire and the attachment bolt **(5)** of the fuel filter head.

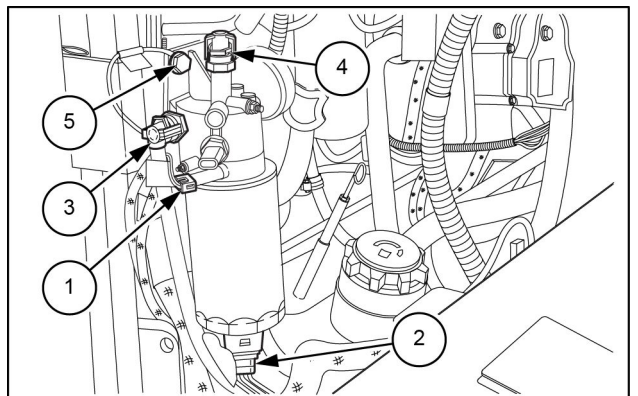

LEIL13WHL0163AB 50

51. Tag and remove the grid heater cable (1).

NOTE: Hold the rear nut with a second wrench to prevent grid heater damage.

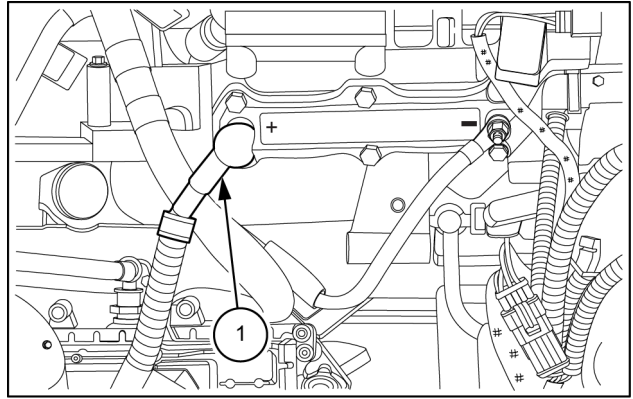

LEIL13WHL0164AB 51

52. Remove wire harness support clamp.

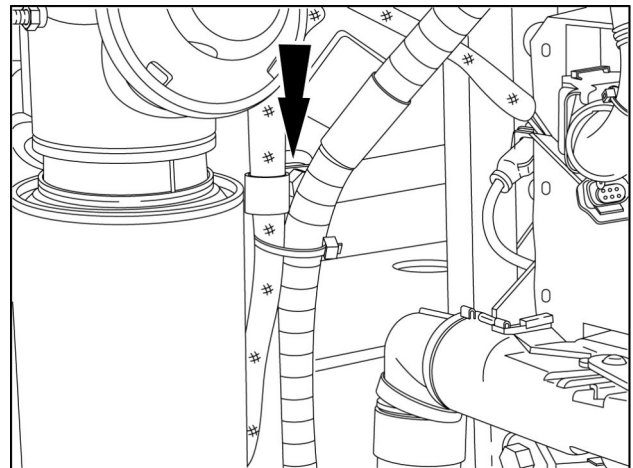

RAPH12WEL0064AA 52

53. Remove the P-clamp and cut the cable ties by the supply module. Disconnect the end of the jumper harness (near the supply module) from the DOC support.

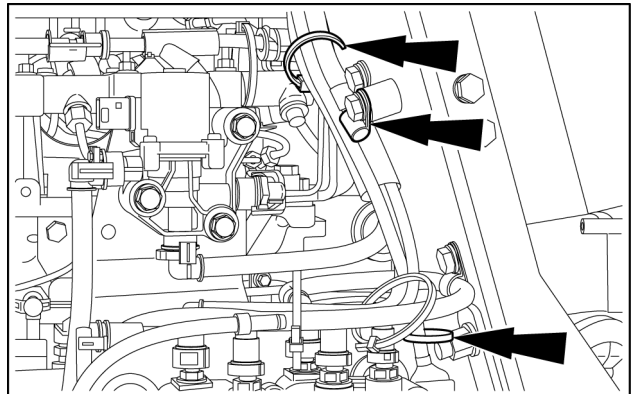

LEIL15WHL0034AB 53

54. Tag and disconnect the NOx controller harness (1), the NH3 sensor connector (4) and the temperature sensor connector (5). Then remove the screws (2) and (3) of the clamp.

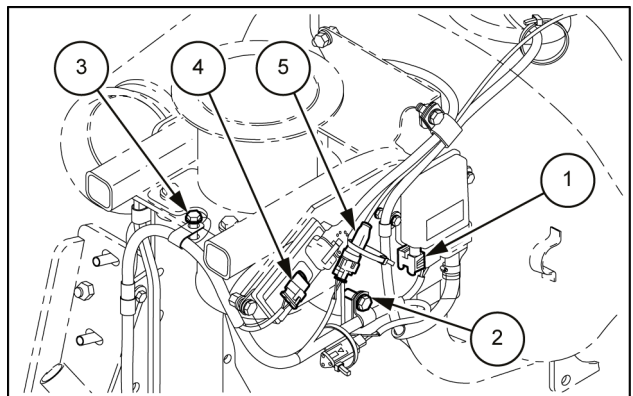

LEIL13WHL0165AB 54

55. Loosen the clamp **(1)** on the Diesel Oxidation Catalyst (DOC).

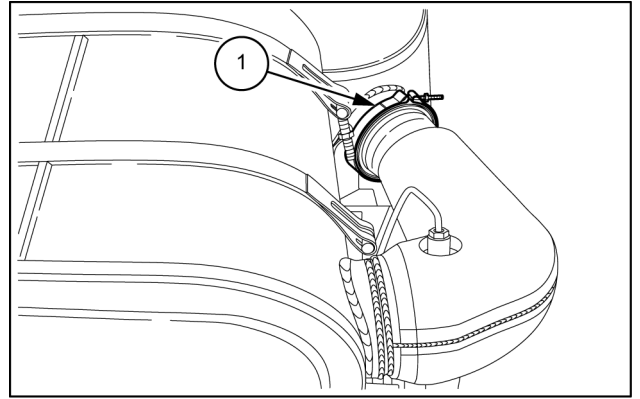

LEIL13WHL0166AB 55

56. Tag and disconnect the connector **(1)**.

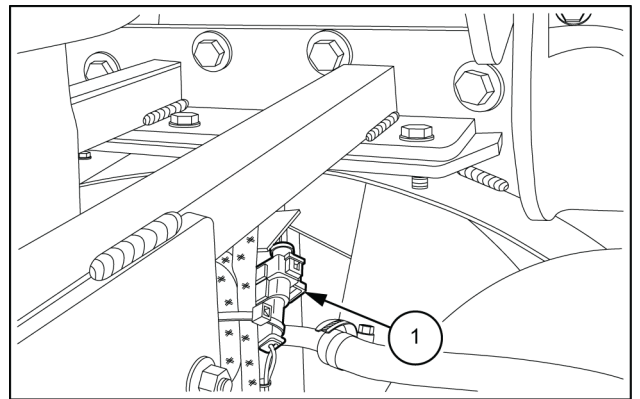

LEIL13WHL0167AB 56

57. Tag and disconnect the wire harness of the temperature sensor **(1)** for the Selective Catalytic Reduction (SCR) muffler (SCR) and cut the connector wire clamps. Loosen the screws and remove the bar **(2)**.

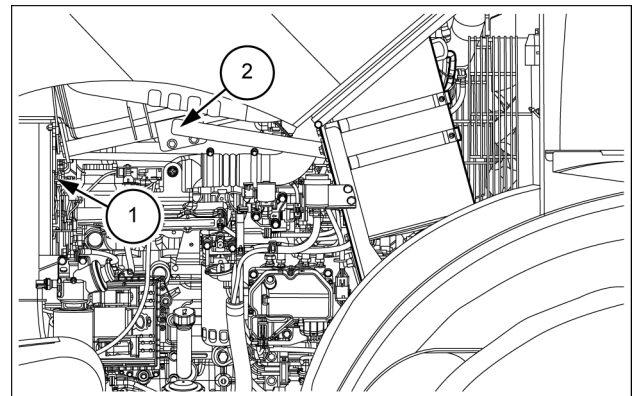

LEIL14WHL0213AB 57

58. Attach a suitable lifting straps to the Selective Catalytic Reduction (SCR) muffler support structure. Remove the bolts securing the support structure at the front **(1)** and rear **(2)** part of the structure. Use a suitable lifting device and carefully lift the support structure of the Selective Catalytic Reduction (SCR) muffler from the machine.

NOTE: Pay particular attention to the connection between the (SCR) muffler and the Diesel Oxidation Catalyst (DOC).

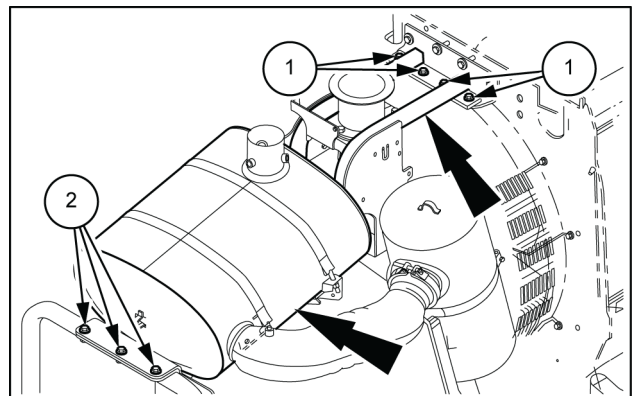

LEIL13WHL0169AB 58

59. Tag and disconnect the wire harness from the buzzer. Remove the bolts (1) securing the front support structure of the (SCR) muffler and remove it.

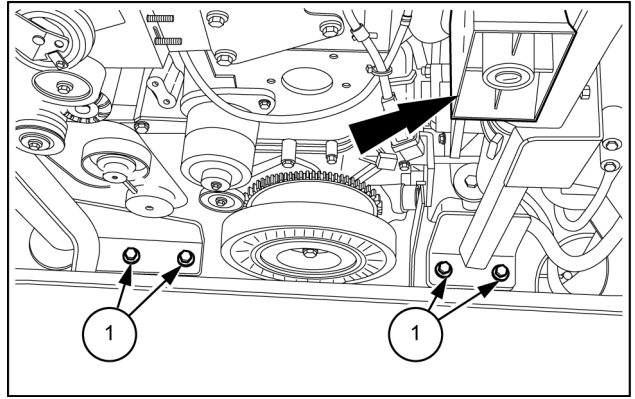

LEIL13WHL0174AB 59

60. Tag and disconnect wire harness from primary fuel filter.

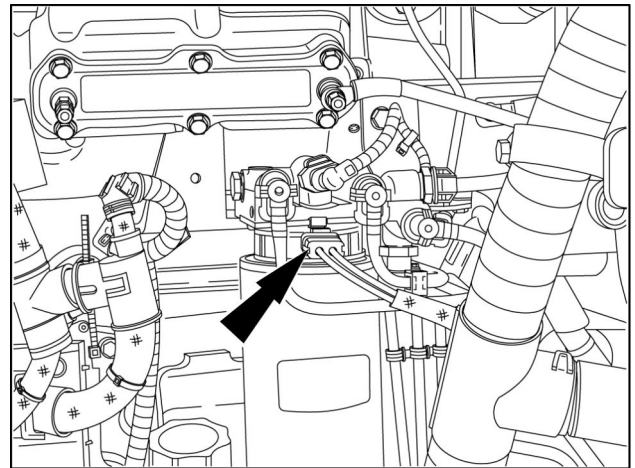

RAPH12WEL0068AA 60

61. Remove DEF/AdBLUE® storage tank cover located on the right hand side of the machine.

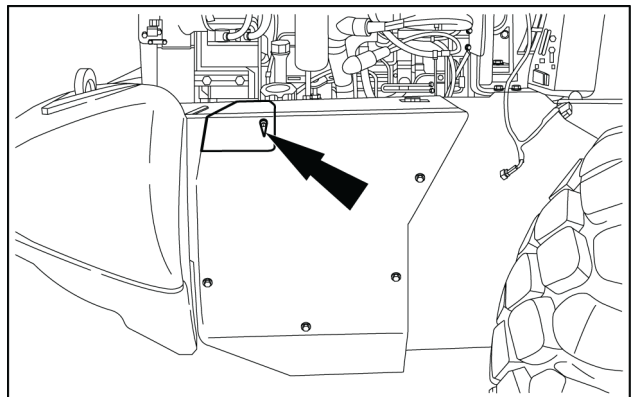

LEIL13WHL0170AB 61

62. Tag and disconnect the wire harness and DEF/AdBLUE® supply and return lines from the DEF/AdBLUE® storage tank. Cap the supply lines.

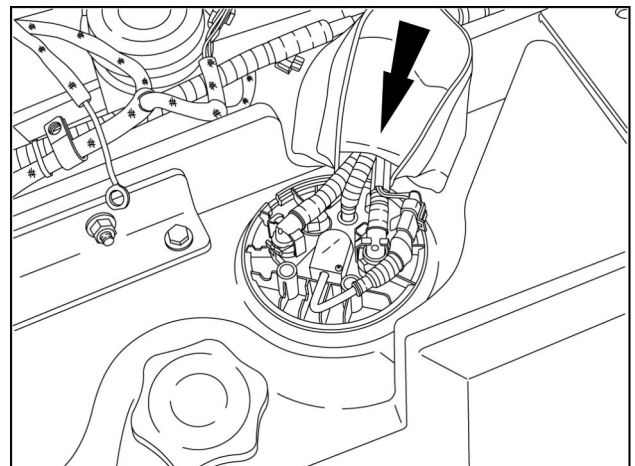

RAPH12WEL0070AA 62

63. Remove the support bracket of the hood lift cylinder.

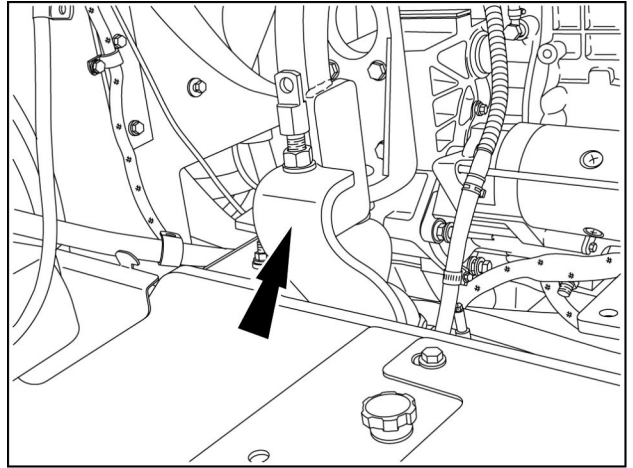

RAPH12WEL0071AA 63

64. Remove the heater hose from the engine.

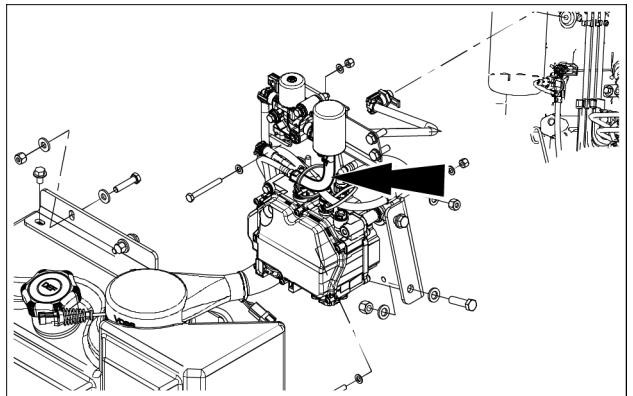

LEIL15WHL0009AB 64

65. Disconnect the main connector of the supply module.

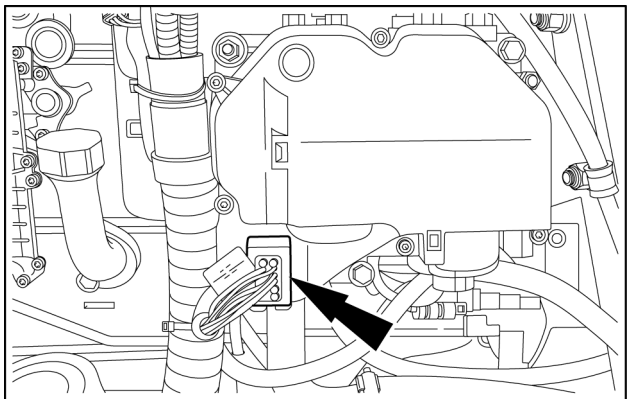

LEIL13WHL0171AB 65

66. Attach suitable lifting straps to the support structure **(1)** of the Diesel Oxidation Catalyst (DOC). The supply module and the coolant control valve are also attached to this support structure.

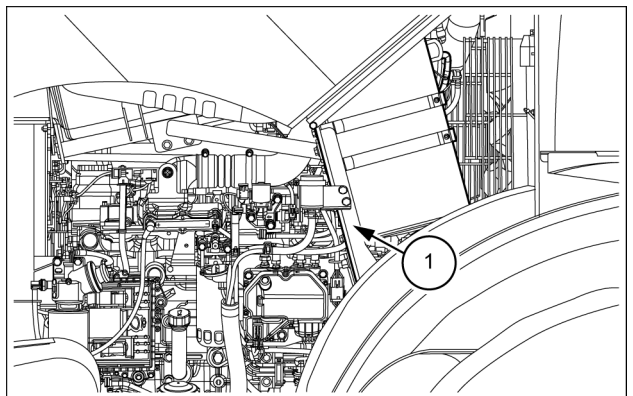

LEIL14WHL0212AB 66

67. Loosen the two hexagonal nuts of the sensors **(3)** and **(4)** and disconnect the sensors **(3)** and **(4)**. Loosen the clamp **(1)** on the Diesel Oxidation Catalyst (DOC) and disconnect the exhaust pipe **(2)** from the Diesel Oxidation Catalyst (DOC).

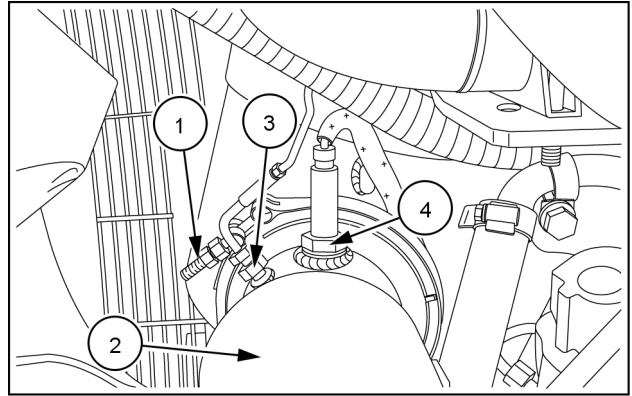

LEIL13WHL0229AA 67

68. Remove the SCR coolant supply line from the engine.

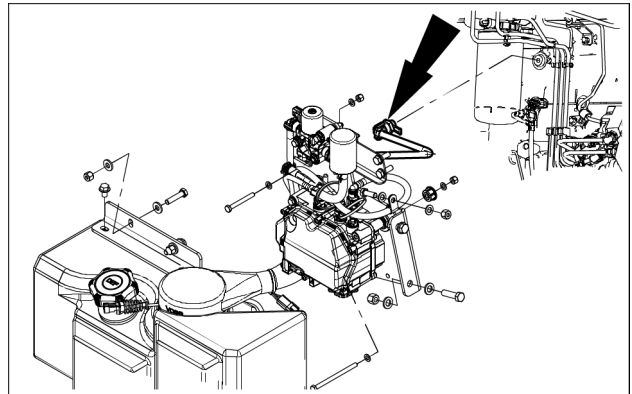

LEIL15WHL0008AB 68

69. Remove the bolts that secure the support structure of the Diesel Oxidation Catalyst (DOC). Use a suitable lifting device and carefully lift the support structure of the Diesel Oxidation Catalyst (DOC) (with SCR system components attached) from the machine.

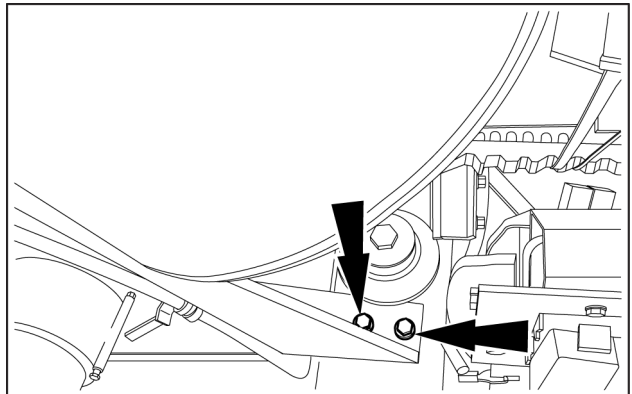

LEIL13WHL0173AB 69

70. Disconnect the wiring harness from the EDC17 controller.

NOTE: Lifting up on the lever will release the connector from the controller.

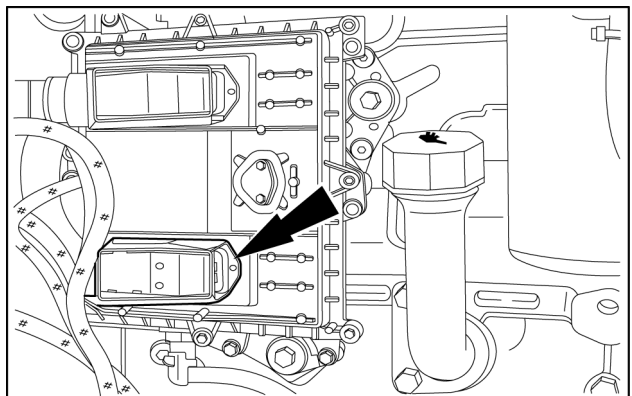

LEIL13WHL0175AB 70

71. Remove the fuel line from the top of the primary fuel filter, plug the line and cap the fitting.

NOTE: Make note on how fuel lines are routed.

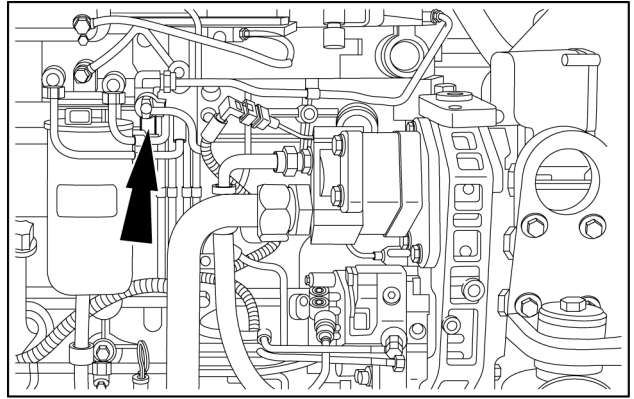

LEIL13WHL0176AB 71

72. Remove the support clamp of the fuel line.

NOTE: Make note on how fuel lines are routed.

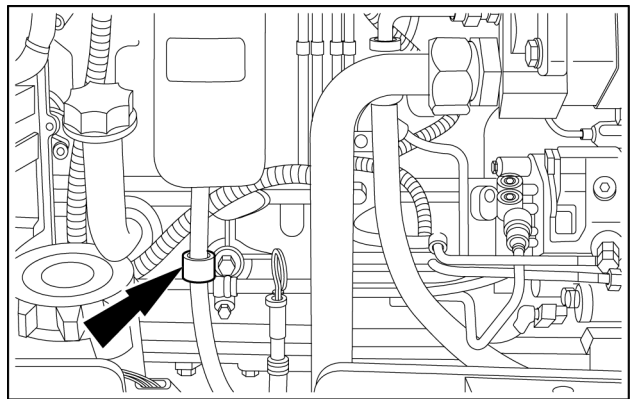

LEIL13WHL0177AB 72

NOTE: make note on how fuel lines are routed, for reference during the reassembly.

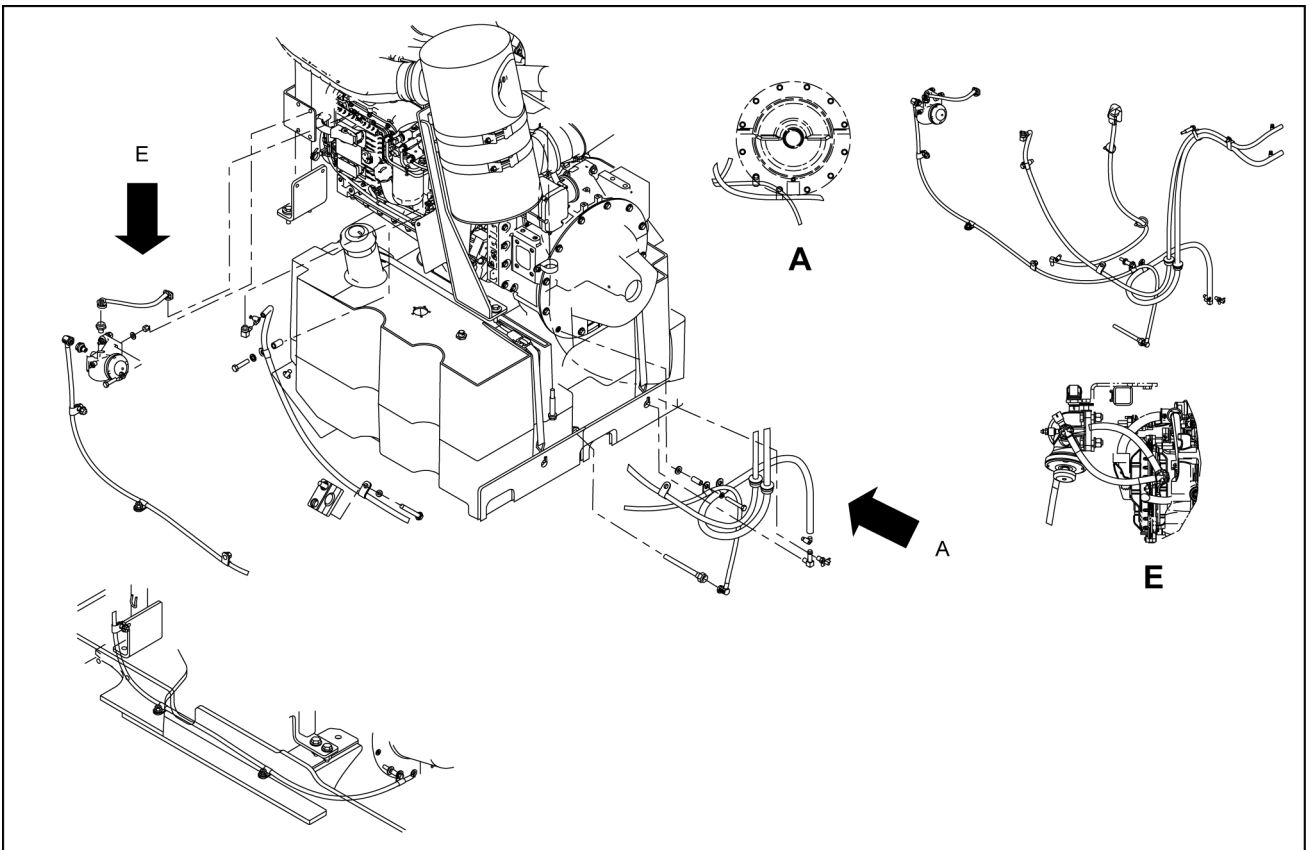

LEIL15WHL0017FB 73

73. Remove the upper and lower covers for the drive shaft.

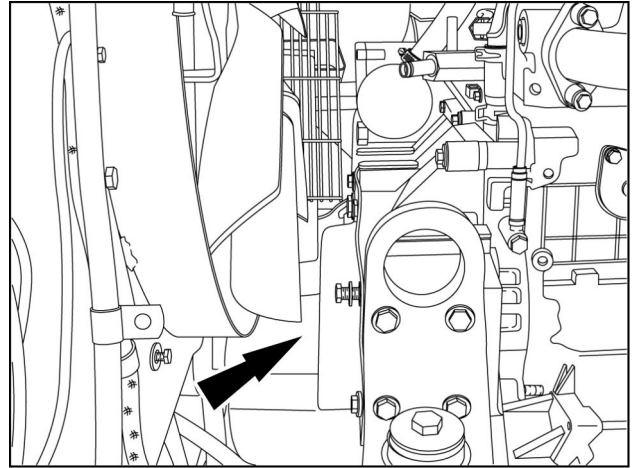

RAPH12WEL0079AA 74

74. Remove the drive shaft bolts (1) from the flywheel. Move the drive shaft clear of the flywheel.

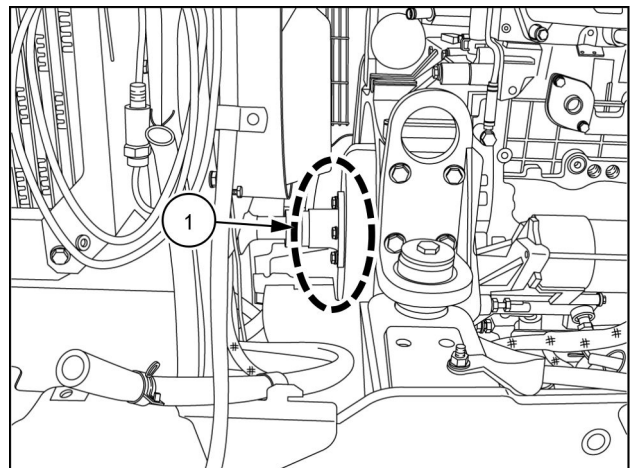

RAPH12WEL0080AA 75

75. Connect and turn on vacuum pump to hydraulic reservoir. Tag and remove the hydraulic lines from the brake system pump (arrow), plug the lines and cap the fittings.

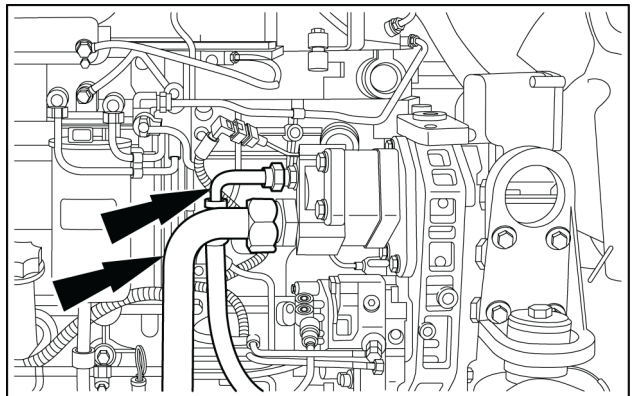

LEIL13WHL0178AB 76



Suggest:

If the above button click is invalid.

Please download this document

first, and then click the above link

to download the complete manual.

Thank you so much for reading

76. Connect suitable lifting equipment to engine lifting brackets. Take up all slack in lifting equipment. Remove the engine mounting bolts.

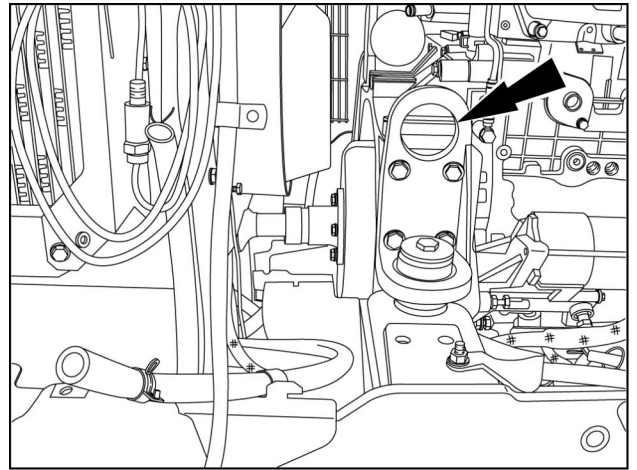

RAPH12WEL0080AA 77

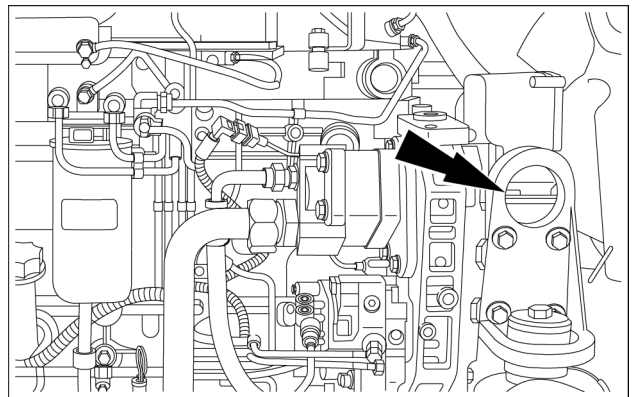

LEIL15WHL0036AA 78

77. Slowly raise engine from rear chassis. Be sure all wire harness connections and hoses have been disconnected and are clear of the engine. Guide the oil drain hose from the frame as the engine is lifted. Remove engine from machine.

<https://www.ebooklibonline.com>

Hello dear friend!

Thank you very much for reading.

Enter the link into your browser.

The full manual is available for immediate download.

<https://www.ebooklibonline.com>