

# 721D Loader Service Manual 6-47283

## Table of Contents

Description	Section No.	Form No.
<b>General</b>		
	<b>Tab 1</b>	
Section Index - General		6-47550
Standard Torque Specifications	1001	8-71603
Fluids and Lubricants	1002	6-47451
Metric Conversion Chart	1003	7-52950
Loctite Product Chart		6-48640
<b>Engines</b>		
	<b>Tab 2</b>	
Section Index - Engines		6-47560
Engine and Radiator Removal and Installation	2000	6-47570
Stall Tests	2002	6-47461
After Cooler	2003	6-49850
For Engine Repair, See the Engine Service Manual		
<b>Fuel System</b>		
	<b>Tab 3</b>	
Section Index - Fuel System		6-47580
For Fuel System Repair, See the Engine Service Manual		
<b>Electrical</b>		
	<b>Tab 4</b>	
Section Index - Electrical		6-47590
Removal and Installation of Starter and Alternator	4001	6-47600
Electrical Specifications and Troubleshooting	4002	6-47470
Batteries	4003	6-42330
Information and Diagnostic Center	4005	6-47611
<b>Steering</b>		
	<b>Tab 5</b>	
Section Index - Steering		6-47620
Removal and Installation of Steering Components	5001	6-47630
Steering Specifications, Pressure Checks, and Troubleshooting	5002	6-47480
Steering Control Valve	5003	6-47640
Steering Priority Valve	5004	6-42400
Steering Cylinders	5005	6-47650
Center Pivot	5006	6-47660
Auxiliary Steering Motor and Pump	5008	6-42430

# 721D Loader Service Manual 6-47283

## Table of Contents

Description	Section No.	Form No.
<b>Power Train</b> <span style="float: right;"><b>Tab 6</b></span>		
Section Index - Power Train		6-47670
Removal and Installation of Power Train Components	6001	6-47681
Transmission Specifications, Pressure Checks, and Troubleshooting	6002	6-47490
Transmission	6003	6-47690
Front Axle	6004	6-47700
Rear Axle	6004	6-47710
Drive Shafts, Center Bearing, and Universal Joints	6005	6-47720
Wheels and Tires	6006	6-47730
Transmission Control Valve	6007	6-42500
<b>Brakes</b> <span style="float: right;"><b>Tab 7</b></span>		
Section Index - Brakes		6-47740
Removal and Installation of Brake Components	7001	6-47750
Hydraulic Brake Troubleshooting	7002	6-47501
Brake Accumulators	7004	6-47761
Parking Brake	7008	6-44971
<b>Hydraulics</b> <span style="float: right;"><b>Tab 8</b></span>		
Section Index - Hydraulics		6-47770
Removal and Installation of Hydraulic Components	8001	6-47782
Hydraulic Specifications, Troubleshooting, and Pressure Checks	8002	6-47512
Cleaning the Hydraulic System	8003	7-49640
Loader Control Valve	8005	6-47800
Cylinders	8006	6-47812
Coupler Solenoid Locking Valve	8007	6-42600
Pilot Pressure Accumulator and Ride Control Accumulator	8013	6-47830
Ride Control Valve	8014	6-44751

# 721D Loader Service Manual 6-47283

## Table of Contents

Description	Section No.	Form No.
<b>Mounted Equipment</b>	<b>Tab 9</b>	
Section Index - Mounted Equipment		6-47840
Air Conditioning Troubleshooting and System Checks For Systems with HFC-134a Refrigerant	9002	6-42650
Air Conditioner System Service	9003	6-47850
Removal and Installation of Air Conditioning Components For Systems with HFC-134a Refrigerant	9004	6-47860
Loader	9006	6-47872
ROPS Cab and ROPS Canopy	9007	6-47880
Cab Glass Installation	9010	6-42710
<b>Electrical Schematic Foldouts and Hydraulic Schematic Foldout</b>	<b>In Rear Pocket</b>	<b>6-47530</b>

**NOTE:** CNH America LLC. reserves the right to make improvements in design or changes in specifications at any time without incurring any obligation to install them on units previously sold.

**<https://www.ebooklibonline.com>**

Hello dear friend!

Thank you very much for reading.

Enter the link into your browser.

The full manual is available for immediate download.

**<https://www.ebooklibonline.com>**

# Section 1001

## GENERAL TORQUE SPECIFICATIONS

## TORQUE SPECIFICATIONS - DECIMAL HARDWARE

Use the torques in this chart when special torques are not given. These torques apply to fasteners with both UNC and UNF threads as received from suppliers dry, or when lubricated with engine oil. Not applicable if special graphities, Molydisulfide greases, or other extreme pressure lubricants are used.

Grade 5 Bolts, Nuts, and Studs		
		
Size	Pound-Inches	Newton metres
1/4 inch	108 to 132	12 to 15
5/16 inch	204 to 252	23 to 28
3/8 inch	420 to 504	48 to 57
Size	Pound-Feet	Newton metres
7/16 inch	54 to 64	73 to 87
1/2 inch	80 to 96	109 to 130
9/16 inch	110 to 132	149 to 179
5/8 inch	150 to 180	203 to 244
3/4 inch	270 to 324	366 to 439
7/8 inch	400 to 480	542 to 651
1.0 inch	580 to 696	787 to 944
1-1/8 inch	800 to 880	1085 to 1193
1-1/4 inch	1120 to 1240	1519 to 1681
1-3/8 inch	1460 to 1680	1980 to 2278
1-1/2 inch	1940 to 2200	2631 to 2983

Grade 8 Bolts, Nuts, and Studs		
		
Size	Pound-Inches	Newton metres
1/4 inch	144 to 180	16 to 20
5/16 inch	288 to 348	33 to 39
3/8 inch	540 to 648	61 to 73
Size	Pound-Feet	Newton metres
7/16 inch	70 to 84	95 to 114
1/2 inch	110 to 132	149 to 179
9/16 inch	160 to 192	217 to 260
5/8 inch	220 to 264	298 to 358
3/4 inch	380 to 456	515 to 618
7/8 inch	600 to 720	814 to 976
1.0 inch	900 to 1080	1220 to 1465
1-1/8 inch	1280 to 1440	1736 to 1953
1-1/4 inch	1820 to 2000	2468 to 2712
1-3/8 inch	2380 to 2720	3227 to 3688
1-1/2 inch	3160 to 3560	4285 to 4827

**NOTE:** Use thick nuts with Grade 8 bolts.

## TORQUE SPECIFICATIONS - METRIC HARDWARE

Use the following torques when specifications are not given.

These values apply to fasteners with coarse threads as received from supplier, plated or unplated, or when lubricated with engine oil. These values do not apply if graphite or Molydisulfide grease or oil is used.

<b>Grade 8.8 Bolts, Nuts, and Studs</b>		
		
Size	Pound-Inches	Newton metres
M4	24 to 36	3 to 4
M5	60 to 72	7 to 8
M6	96 to 108	11 to 12
M8	228 to 276	26 to 31
M10	456 to 540	52 to 61
Size	Pound-Feet	Newton metres
M12	66 to 79	90 to 107
M14	106 to 127	144 to 172
M16	160 to 200	217 to 271
M20	320 to 380	434 to 515
M24	500 to 600	675 to 815
M30	920 to 1100	1250 to 1500
M36	1600 to 1950	2175 to 2600

<b>Grade 10.9 Bolts, Nuts, and Studs</b>		
		
Size	Pound-Inches	Newton metres
M4	36 to 48	4 to 5
M5	84 to 96	9 to 11
M6	132 to 156	15 to 18
M8	324 to 384	37 to 43
Size	Pound-Feet	Newton metres
M10	54 to 64	73 to 87
M12	93 to 112	125 to 150
M14	149 to 179	200 to 245
M16	230 to 280	310 to 380
M20	450 to 540	610 to 730
M24	780 to 940	1050 to 1275
M30	1470 to 1770	2000 to 2400
M36	2580 to 3090	3500 to 4200

### Grade 12.9 Bolts, Nuts, and Studs

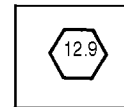

Usually the torque values specified for grade 10.9 fasteners can be used satisfactorily on grade 12.9 fasteners.

## TORQUE SPECIFICATIONS - STEEL HYDRAULIC FITTINGS

Tube OD Hose ID	Thread Size	Pound- Inches	Newton metres
<b>37 Degree Flare Fitting</b>			
1/4 inch 6.4 mm	7/16-20	72 to 144	8 to 16
5/16 inch 7.9 mm	1/2-20	96 to 192	11 to 22
3/8 inch 9.5 mm	9/16-18	120 to 300	14 to 34
1/2 inch 12.7 mm	3/4-16	180 to 504	20 to 57
5/8 inch 15.9 mm	7/8-14	300 to 696	34 to 79
Tube OD Hose ID	Thread Size	Pound- Feet	Newton metres
3/4 inch 19.0 mm	1-1/16-12	40 to 80	54 to 108
7/8 inch 22.2 mm	1-3/16-12	60 to 100	81 to 135
1.0 inch 25.4 mm	1-5/16-12	75 to 117	102 to 158
1-1/4 inch 31.8 mm	1-5/8-12	125 to 165	169 to 223
1-1/2 inch 38.1 mm	1-7/8-12	210 to 250	285 to 338

Tube OD Hose ID	Thread Size	Pound- Inches	Newton metres
<b>Straight Threads with O-ring</b>			
1/4 inch 6.4 mm	7/16-20	144 to 228	16 to 26
5/16 inch 7.9 mm	1/2-20	192 to 300	22 to 34
3/8 inch 9.5 mm	9/16-18	300 to 480	34 to 54
1/2 inch 12.7 mm	3/4-16	540 to 804	57 to 91
Tube OD Hose ID	Thread Size	Pound- Feet	Newton metres
5/8 inch 15.9 mm	7/8-14	58 to 92	79 to 124
3/4 inch 19.0 mm	1-1/16-12	80 to 128	108 to 174
7/8 inch 22.2 mm	1-3/16-12	100 to 160	136 to 216
1.0 inch 25.4 mm	1-5/16-12	117 to 187	159 to 253
1-1/4 inch 31.8 mm	1-5/8-12	165 to 264	224 to 357
1-1/2 inch 38.1 mm	1-7/8-12	250 to 400	339 to 542

<b>Split Flange Mounting Bolts</b>		
Size	Pound- Inches	Newton metres
5/16-18	180 to 240	20 to 27
3/8-16	240 to 300	27 to 34
7/16-14	420 to 540	47 to 61
Size	Pound- Feet	Newton metres
1/2-13	55 to 65	74 to 88
5/8-11	140 to 150	190 to 203

# Section 2000

## ENGINE AND RADIATOR REMOVAL AND INSTALLATION

# ENGINE

## Removal

### STEP 1

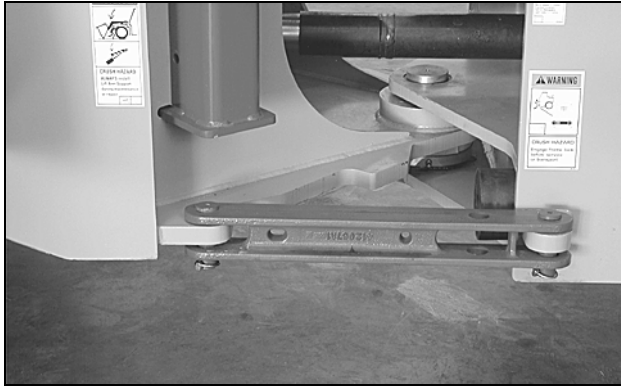

BD03A040

Park machine on a level surface and lower bucket to ground. Put articulation lock in LOCKED position.

### STEP 2

Stop engine. Actuate brake pedal several times to discharge brake accumulators. Put key switch in ON position and move loader control lever back and forth at least 30 times to release any pressure from hydraulic circuit. Put key switch in OFF position.

### STEP 3

Slowly loosen the filler cap for hydraulic reservoir to release air pressure in hydraulic reservoir.

### STEP 4

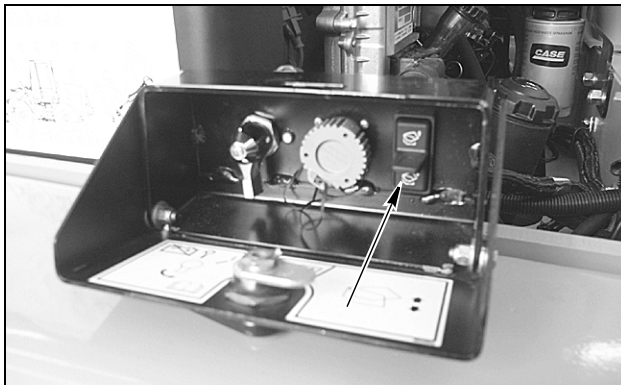

BD03A222

Raise the hood with the hood lift motor. Put master disconnect switch in OFF position. Remove both battery covers and disconnect batteries from the machine.

### STEP 5

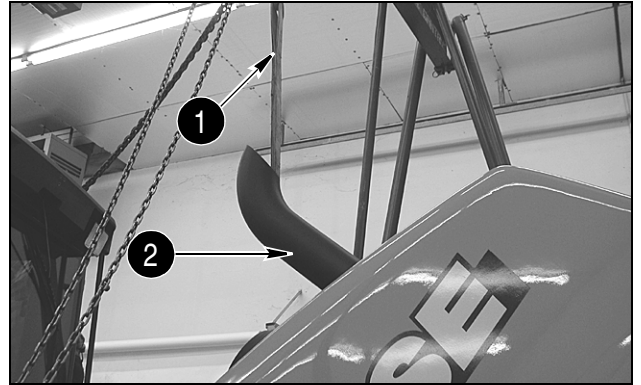

BD03A231

Double up a nylon lifting strap (1) and slide through the exhaust stack (2) on the hood.

### STEP 6

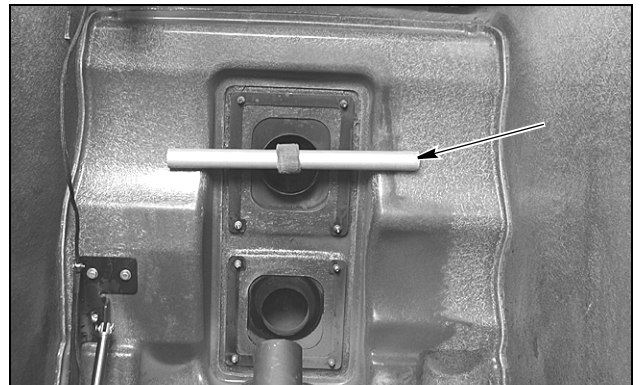

BD03A230

Place a solid steel bar through the strap, raise the hood and release tension on the lifting motor.

### STEP 7

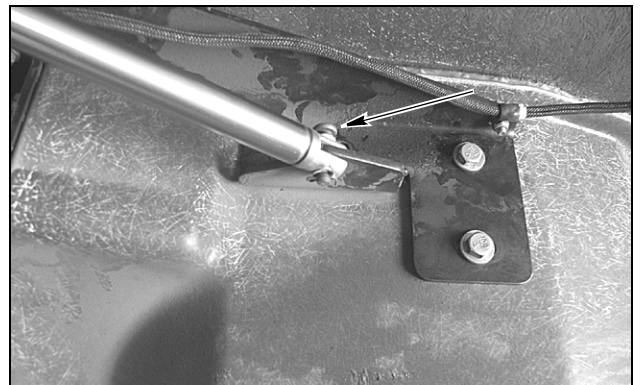

BD03A228

Remove the pin from the top of the lifting motor.

### STEP 8

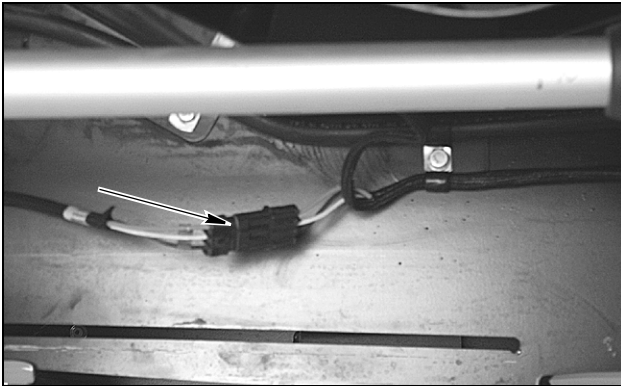

BD03A223

Tag and disconnect hood wiring harness connector from rear chassis wiring harness connector.

### STEP 9

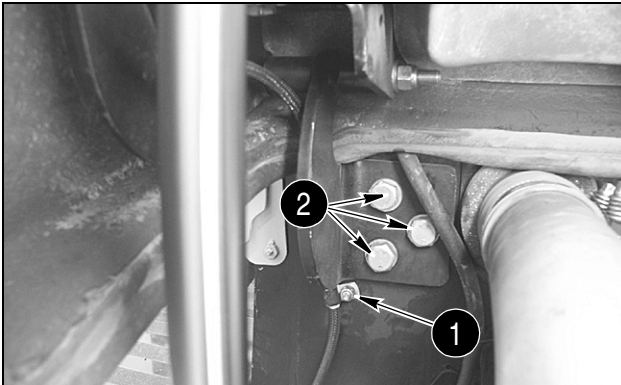

BD03A227

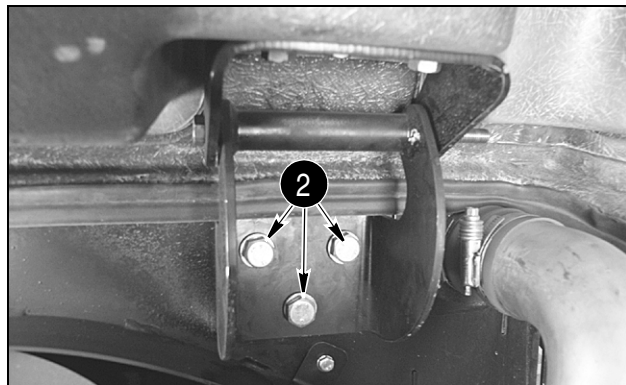

BD03A226

Remove mount bolt (1) and backup alarm wiring harness clamp from cooler housing. Have another person balance the hood and remove the hood hinge mounting bolts (2) from the cooler frame.

### STEP 10



BD03A232

Carefully raise and remove hood from loader. Lower hood onto suitable platform and disconnect lifting equipment.

### STEP 11

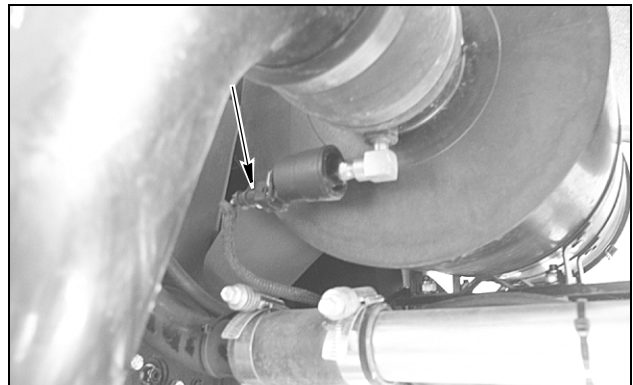

BD03A224

Tag and disconnect engine wiring harness connector from air filter restriction switch.

### STEP 12

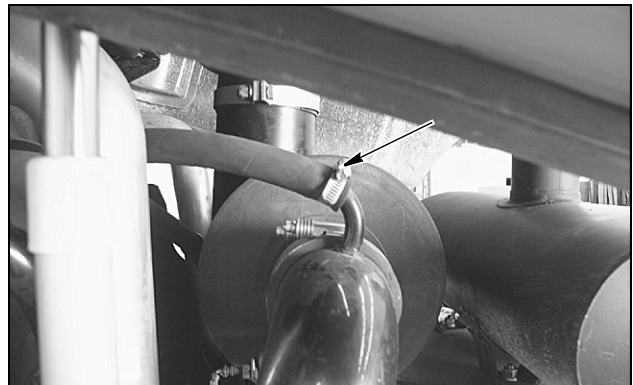

BD03A225

Loosen clamp on air cleaner intake hose and remove the crankcase ventilation hose.

**STEP 13**

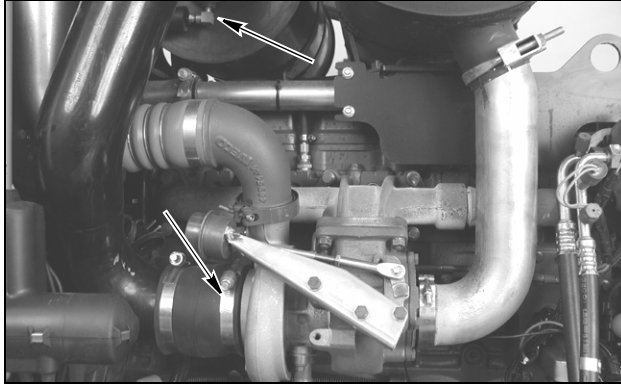

Loosen clamps on turbocharger and air cleaner, remove the intake hose.

**STEP 14**

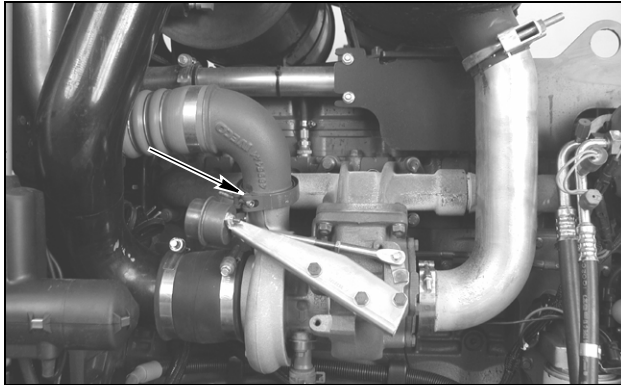

Loosen the clamp on the turbocharger for the after cooler inlet hose.

**STEP 15**



Loosen the clamp on the after cooler and remove the after cooler inlet hose from the machine.

**STEP 16**

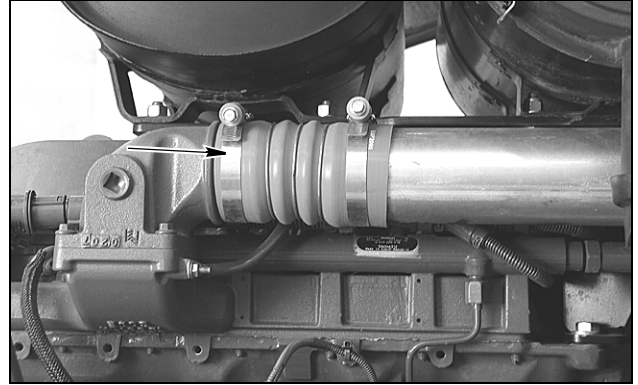

Loosen the clamp on the intake manifold for the after cooler output hose.

**STEP 17**



Loosen the clamp on the after cooler and remove the after cooler outlet hose from the machine.

**STEP 18**



Put a 25.5 liter (6.75 gallon) container below radiator drain. Remove radiator cap. Remove cap and drain coolant into container. Install cap after coolant has drained. Install radiator cap.

**STEP 19**

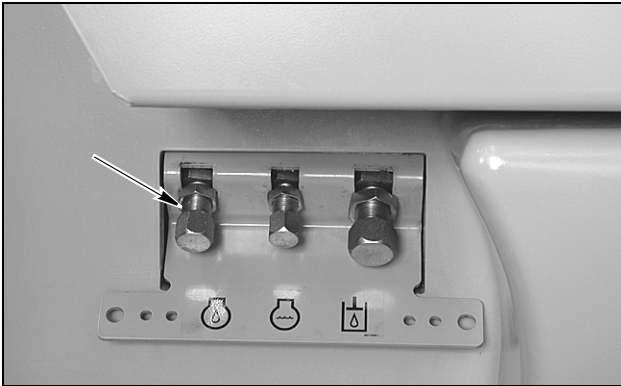

BD02N160

Put a 14.2 liter (15 U.S. quarts) container below engine oil drain. Remove cap and drain oil into container. Install cap after oil has drained.

**NOTE:** After draining oil disconnect drain hose from frame for removal with engine.

**STEP 20**

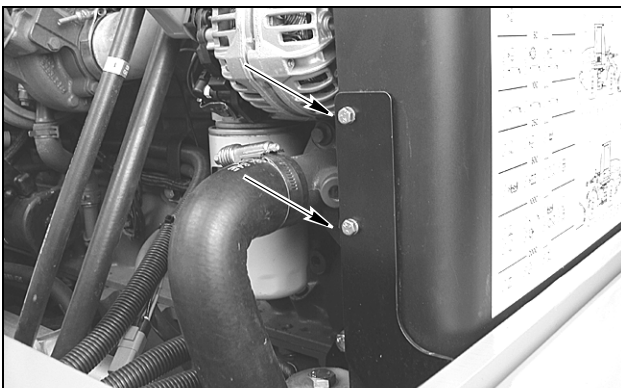

BD03A128

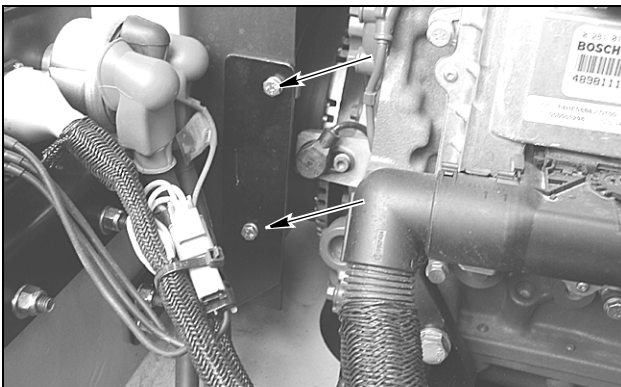

BD03A129

Remove the four mounting bolts from the belt cover, remove the cover.

**NOTE:** After removing the belt cover remove the cover mounting brackets from the machine frame.

**STEP 21**

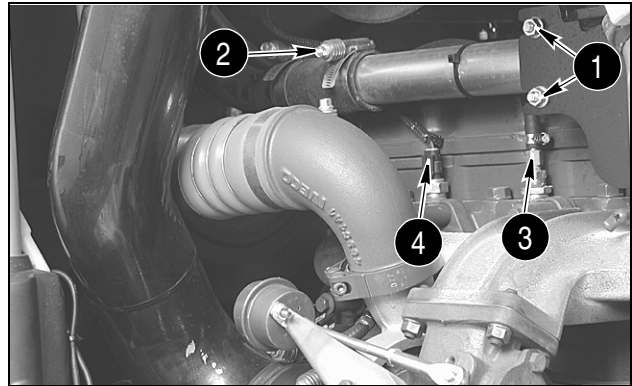

BD03A147

Loosen and remove the two nuts (1) and washers from the upper coolant pipe support clamp, remove the clamp. Loosen the coolant pipe clamp (2). Disconnect the engine coolant vent line (3). Tag and disconnect the coolant temperature sending unit (4).

**STEP 22**

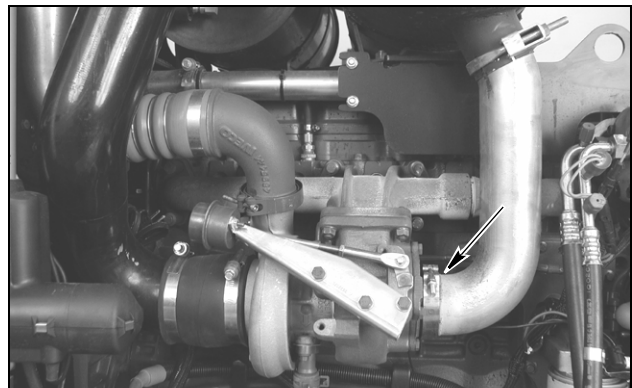

BD03A137

Loosen the exhaust clamp from the turbocharger.

**STEP 23**

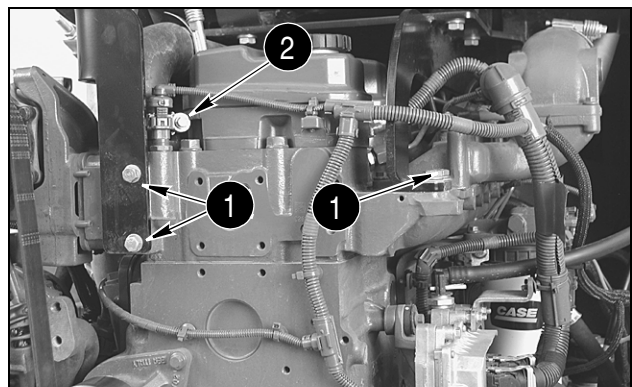

BD03A140

Loosen the upper coolant line hose clamp (2), remove the hose and pipe from the machine. Attach suitable lifting equipment to the muffler and air cleaner bracket. Remove the four front muffler and air cleaner bracket mounting bolts (1).

**STEP 24**

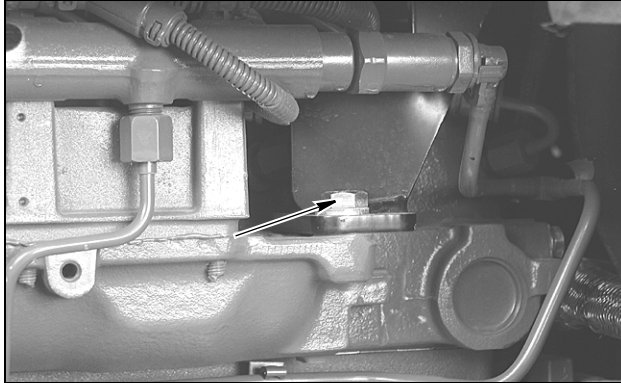

BD03A145

Remove the rear bracket mounting bolt. Remove two brace mounting bolts from the bell housing. Remove the bracket, muffler, and air cleaner from the machine.

**NOTE:** Make sure fuel lines and electrical wiring do not become entangled in the bracket during removal.

**STEP 25**

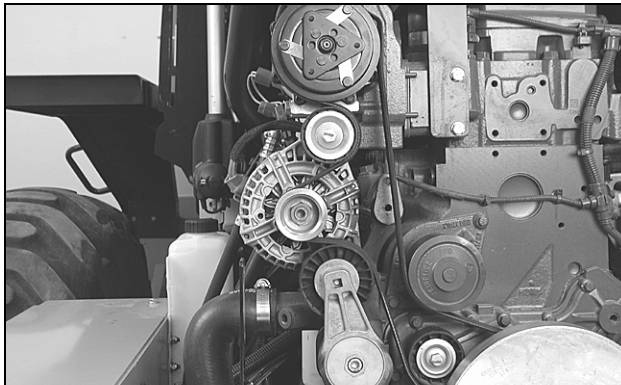

BD03A134

Remove the drive belt from the engine.

**STEP 26**

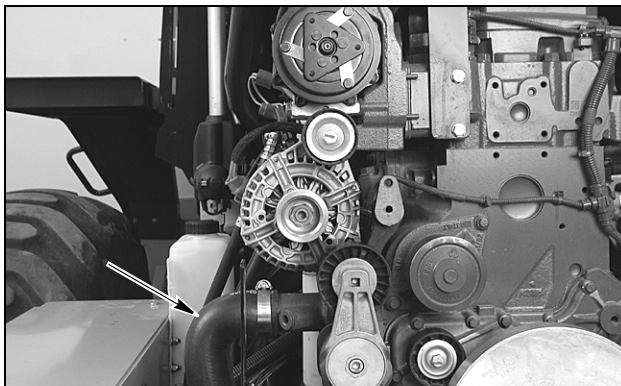

BD03A132

Loosen clamps and remove lower cooler hose from the engine.

**STEP 27**

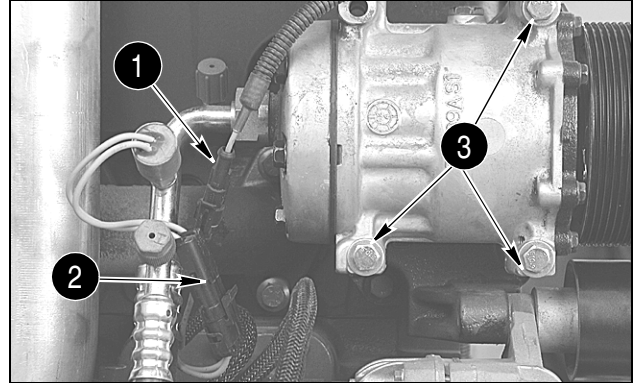

BD03A131

If loader is equipped with air conditioning, identify, tag, and disconnect the engine wiring harness connectors from air compressor clutch connector (1) and high pressure switch connector (2). Remove the three mounting bolts (3) for the compressor and set the compressor on the left battery cover.

**STEP 28**

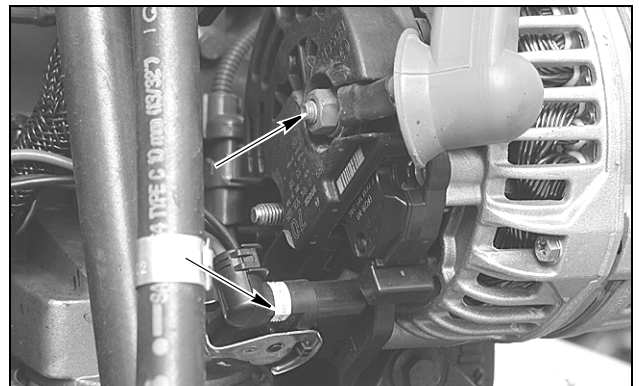

BD03A130

Tag and disconnect the wiring from the alternator.

**STEP 29**



BD03A136

Remove bolt securing wiring harness clamp to engine.

### STEP 30

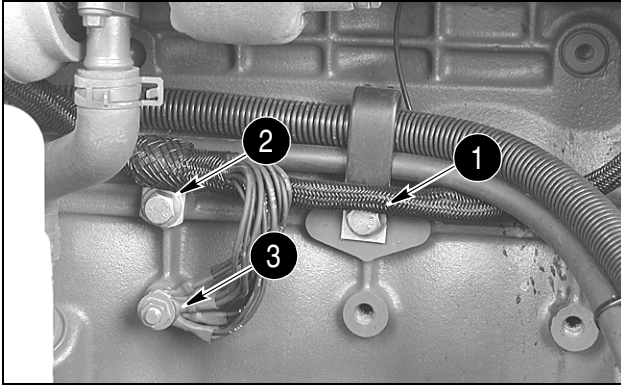

BD03A135

Remove bolts securing wiring harness (2), starter battery cables (1), clamps to the engine. Remove ground wires (3) from the engine.

### STEP 31



BD03A127

Remove the rubber cap from the starter solenoid cover.

### STEP 32

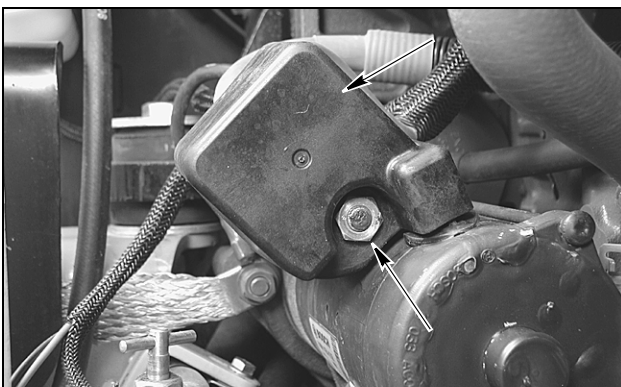

BD03A126

Remove the starter solenoid cover mounting nut, remove the cover.

### STEP 33

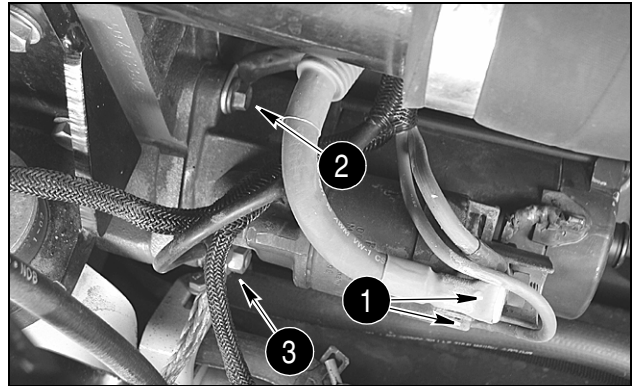

BD03A123

Tag and remove the wires from the starter solenoid (1), remove the ground cable (2), and ground strap (3) from the starter.

**NOTE:** Move the starter cables to the rear of the machine and away from the engine, move the wiring harness to the bell housing of the engine.

### STEP 34

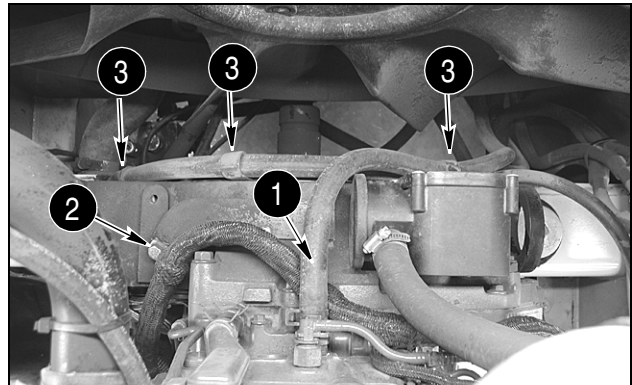

BD03A215

Remove the heater hose (1) from the rear of the engine, remove the mount bolt and wiring harness clamp (2), remove the clamp bolts and clamps (3) from the bell housing.

**NOTE:** Move the wiring harness to the right side of the engine.

**STEP 35**

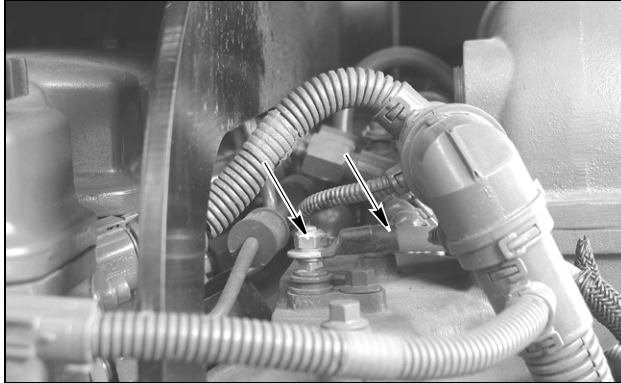

BD03A144

Tag and remove the grid heater cable.

**STEP 36**

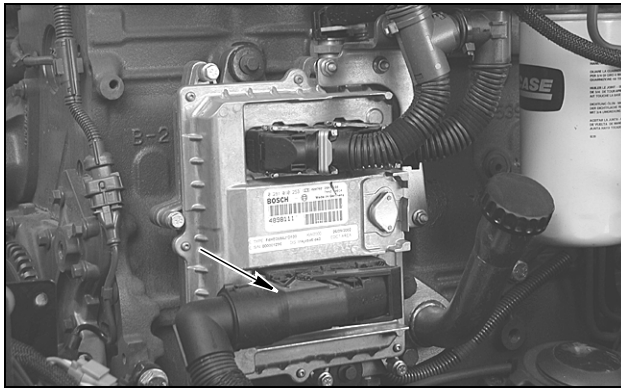

BD03A142

Disconnect the wiring harness from the EDC 7 controller.

**NOTE:** *Lifting up on the lever will release the connector from the controller.*

**STEP 37**

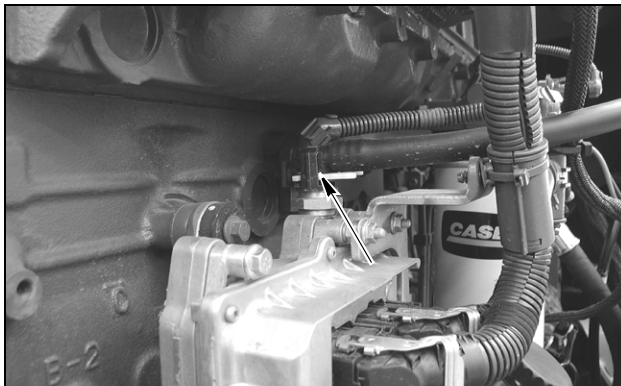

BD03A182

Remove the fuel line from the top of the EDC 7 controller, plug the line and cap the fitting.

**STEP 38**

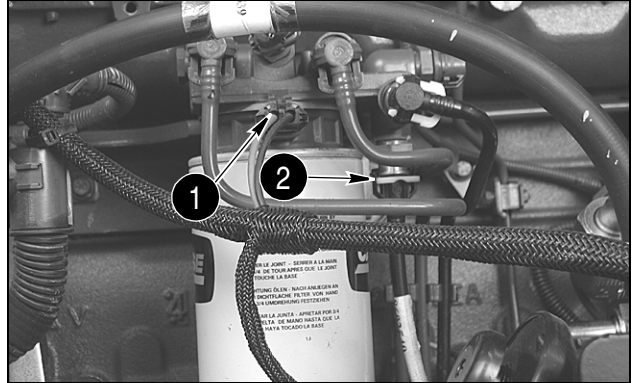

BD03A148

Tag and disconnect the fuel filter heater wires (1), disconnect the fuel line (2) from the fuel filter head, plug the line and cap the fitting.

**STEP 39**

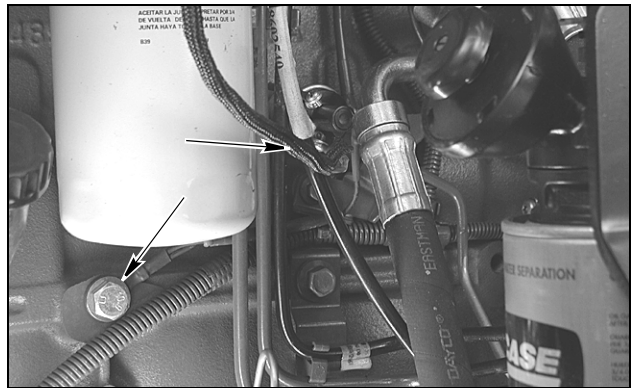

BD03A150

Tag and disconnect the wiring harness from the engine oil pressure switch. Remove the ground wires from the engine.

**NOTE:** *Move the wiring harness toward the front of the machine and away from the engine.*

### STEP 40

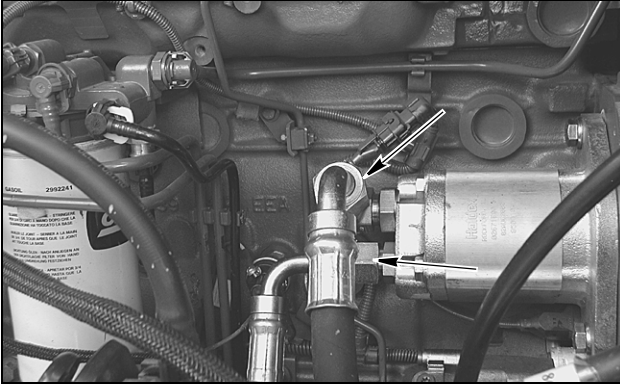

BD03A149

Connect and turn on vacuum pump to hydraulic reservoir. Tag and remove the hydraulic lines from the brake system pump, plug the lines and cap the fittings.

### STEP 41

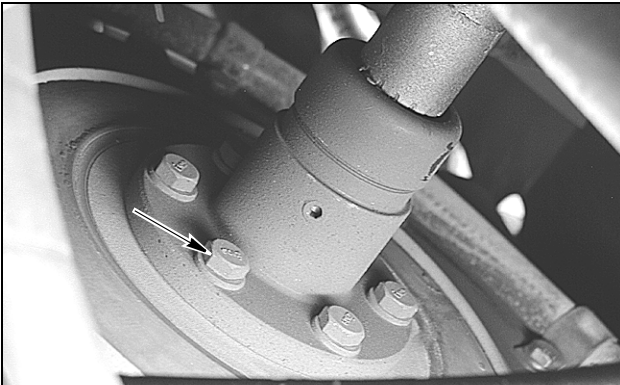

BD03A172

Remove the drive shaft bolts from the flywheel. Move the drive shaft clear of the flywheel.

### STEP 42

Connect suitable lifting equipment to engine lifting brackets. Take up all slack in lifting equipment. Remove the engine mounting bolts and lift the engine enough to gain access to the drain hose.

### STEP 43

Slowly raise engine from rear chassis. Be sure all harness connections and hoses have been disconnected and are clear of the engine. Remove engine from machine.

# Installation

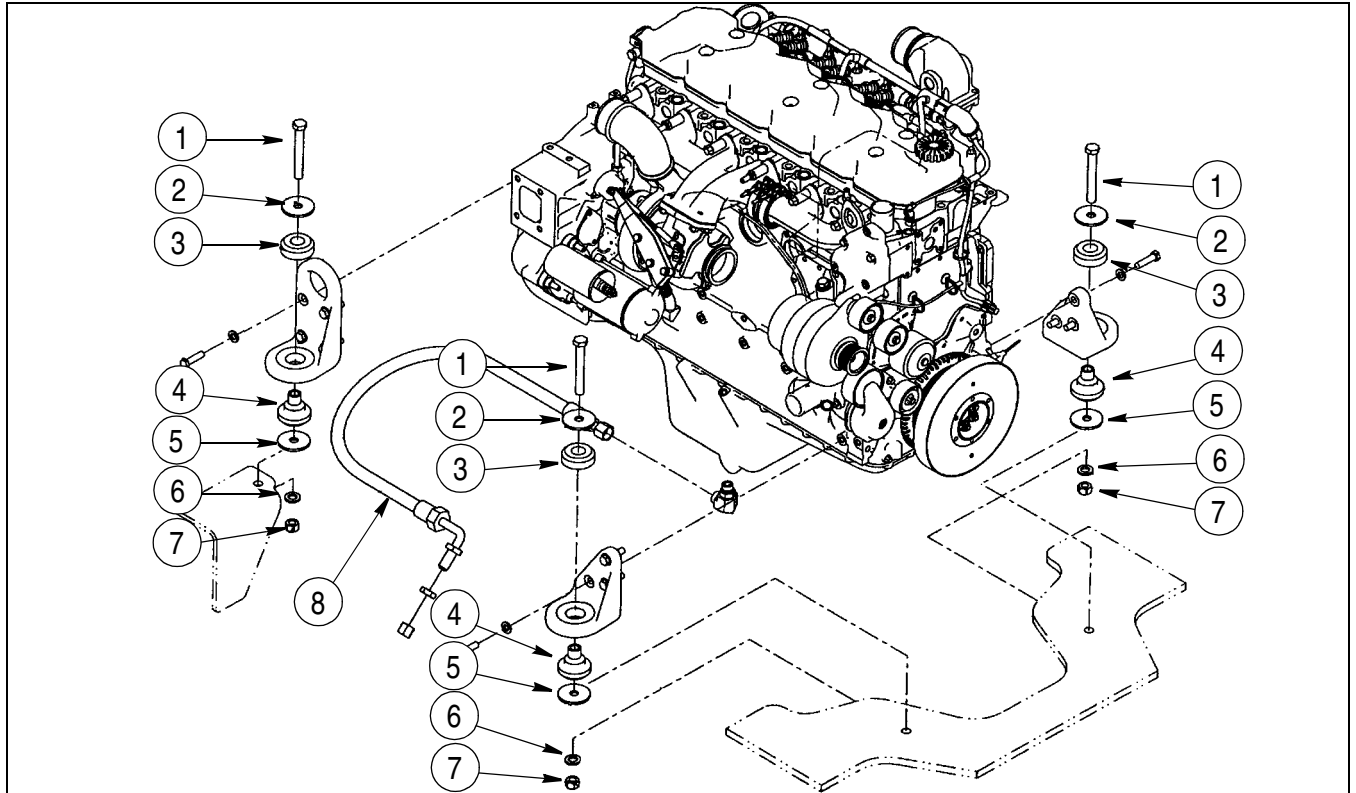

BS03B035

1. ENGINE MOUNT BOLT  
2. WASHER

3. INSOLATOR UPPER  
4. INSOLATOR LOWER

5. WASHER  
6. WASHER

7. NUT  
8. REMOTE OIL DRAIN HOSE

## STEP 44

If engine rubber isolators require replacement, remove and discard isolators (3 and 4). Install new rubber isolator (4), then rubber isolator (3).

## STEP 45

Slowly raise engine and move into position over rear chassis. Be sure all harness connections and hoses are out of the way then lower engine. Put washer (5) between front rubber isolator (4) and chassis. Install washer (2), bolt (1), washer (6), and nut (7) in engine isolators. Lower engine into position.

## STEP 46

Tighten engine mounting bolts to a torque of 244 to 298 Nm (180 to 220 lb-ft).

## STEP 47

Disconnect lifting equipment from engine lifting brackets.

## STEP 48

Connect engine oil drain hose to frame bracket.

## STEP 49

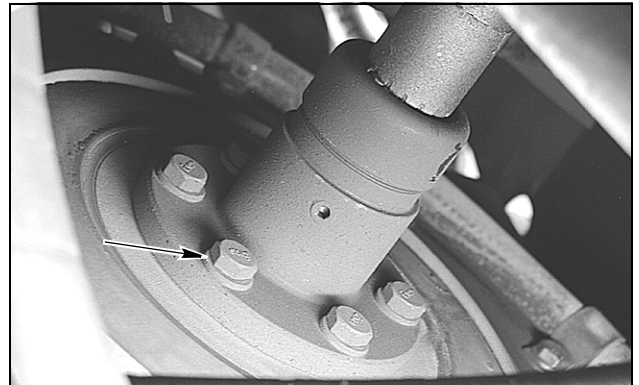

BD03A172

At front of engine, position drive shaft on engine coupling. Install six bolts to secure drive shaft to engine coupling. Tighten the six bolts to a torque of 53 to 62 Nm (39 to 46 lb-ft).

**STEP 50**

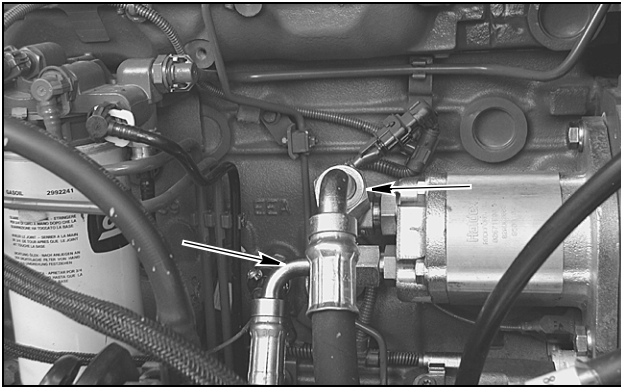

BD03A149

Connect and turn on vacuum pump to the hydraulic reservoir. Remove caps from fittings and plugs from hoses. Connect hoses to brake pump following tags installed during removal. Remove and discard tags. Turn off and disconnect vacuum pump from hydraulic reservoir.

**STEP 51**

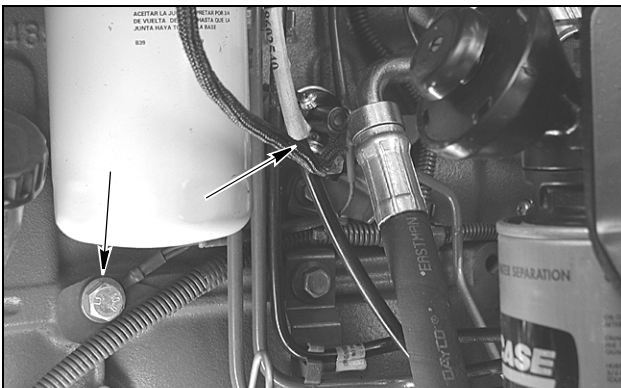

BD03A150

Connect wiring harness to oil pressure switch, connect grounding wire to engine block. Remove and discard tag.

**STEP 52**

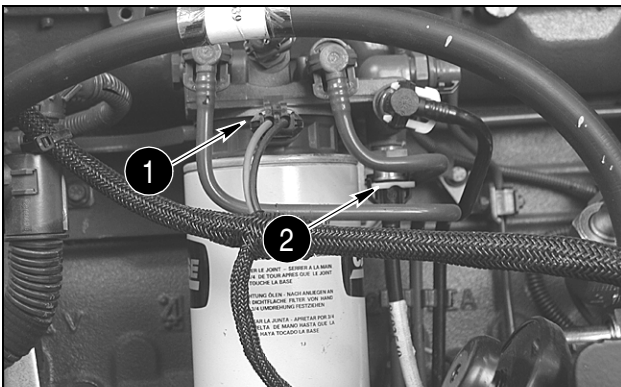

BD03A148

Remove cap from fitting and plug from the hose, connect fuel line (2). Connect fuel filter heater wires (1). Remove and discard tag.

**STEP 53**

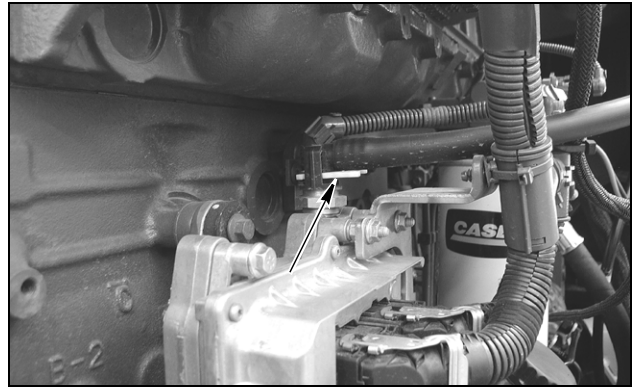

BD03A182

Remove cap from fitting and plug from the hose, connect fuel line to EDC 7.

**STEP 54**

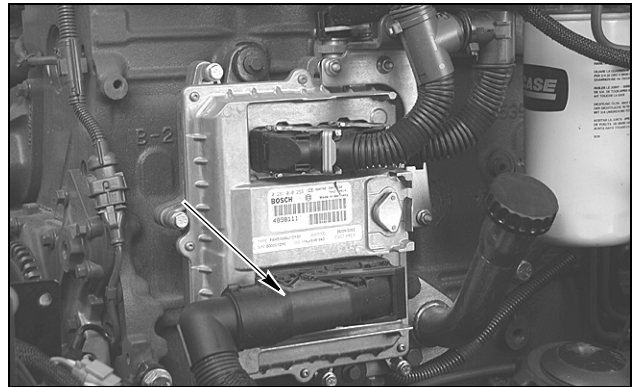

BD03A142

Connect wiring harness to EDC 7 controller.

**NOTE:** Start the connector on the EDC 7 with lever straight out from EDC 7. Use lever to pull connector into position.

**STEP 55**



BD03A144

Connect grid heater cable to grid heater. Remove and discard tag.

**STEP 56**

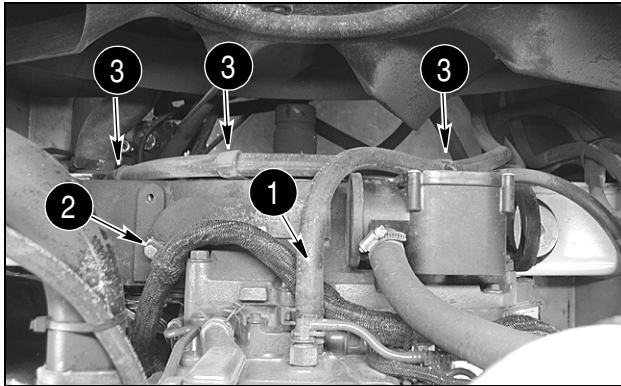

BD03A215

Install the heater hose (1) to the rear of the engine, mount the wiring harness clamp (2), install the clamps (3) to the bell housing.

**STEP 57**

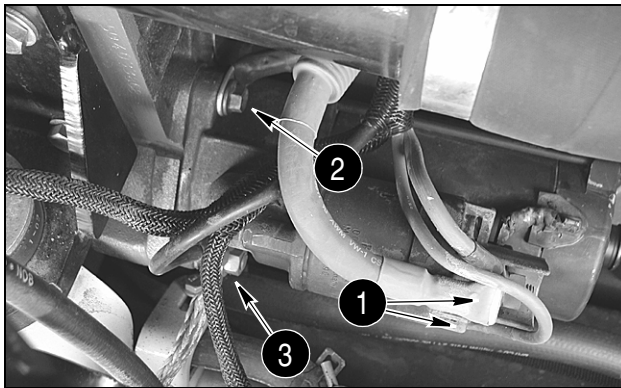

BD03A123

Install the wires to the starter solenoid (1), install the ground cable (2), and ground strap (3) to the starter. Remove and discard tags.

**STEP 58**

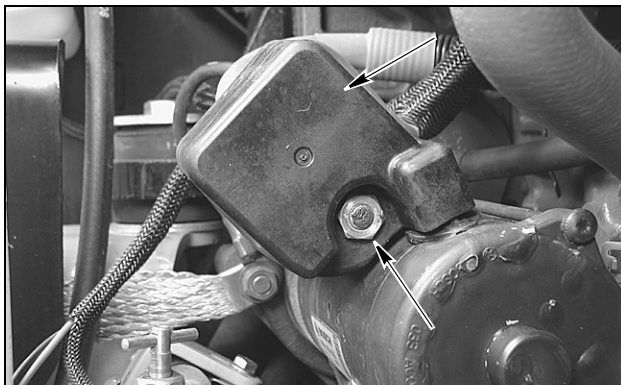

BD03A126

Install the starter solenoid cover and secure with mounting nut.

**STEP 59**



BD03A127

Install the rubber cap on the starter solenoid cover nut.

**STEP 60**

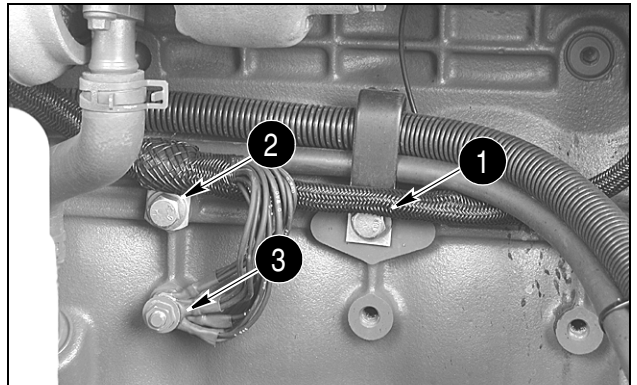

BD03A135

Install bolts securing wiring harness (2), starter battery cables (1), clamps to the engine. Install ground wires (3) to the engine.

**STEP 61**



BD03A136

Install bolt securing wiring harness clamp to engine.

### STEP 62

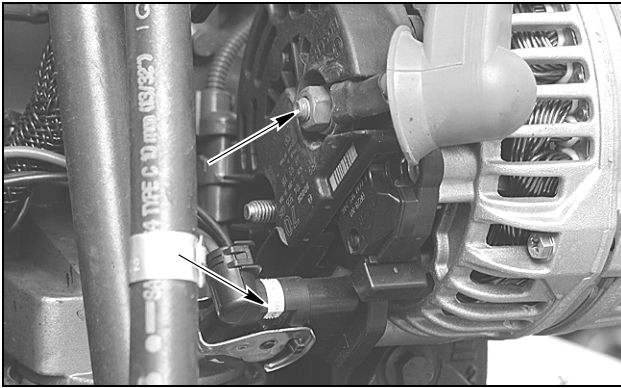

BD03A130

Connect the wiring to the alternator. Remove and discard tags.

### STEP 63

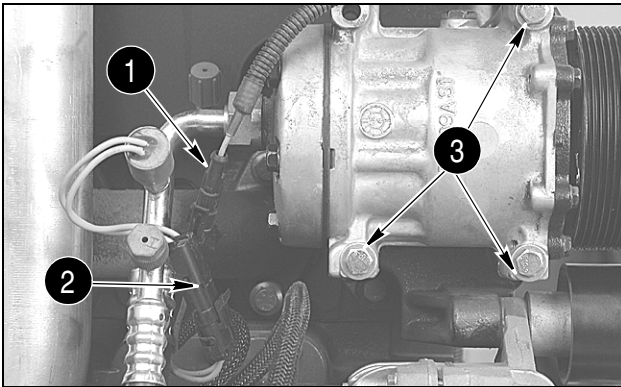

BD03A131

If loader is equipped with air conditioning, mount the compressor using the three mounting bolts (3), connect the engine wiring harness connectors to air compressor clutch connector (1) and high pressure switch connector (2). Remove and discard tags.

### STEP 64

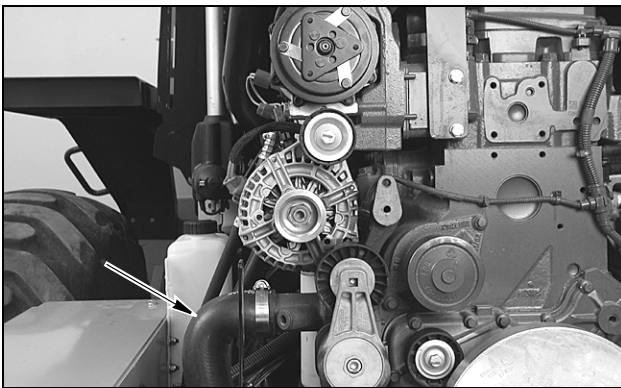

BD03A132

Install lower cooler hose to the engine and tighten the clamps to a torque of 10.1 to 11.3 Nm (90 to 100 lb-inch).

### STEP 65

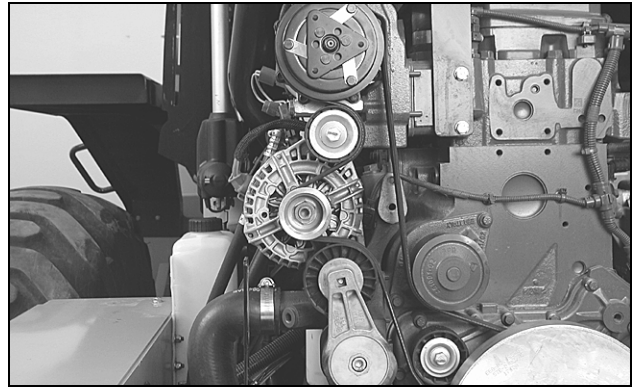

BD03A134

Install the drive belt.

### STEP 66

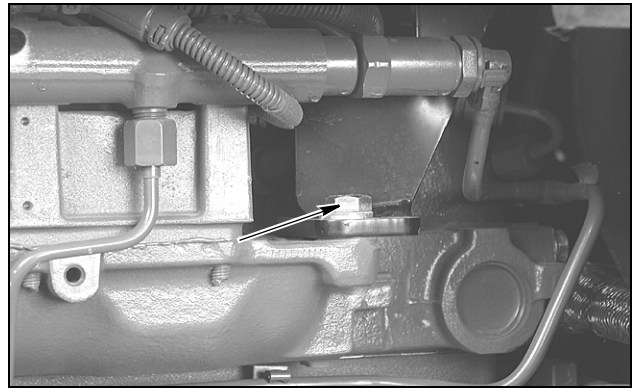

BD03A145

Place the bracket, muffler, and air cleaner over the engine. Install the rear bracket mounting bolt. Install two brace mounting bolts in the bell housing.

**NOTE:** Make sure fuel lines and electrical wiring do not become entangled in the bracket during installation.

### STEP 67

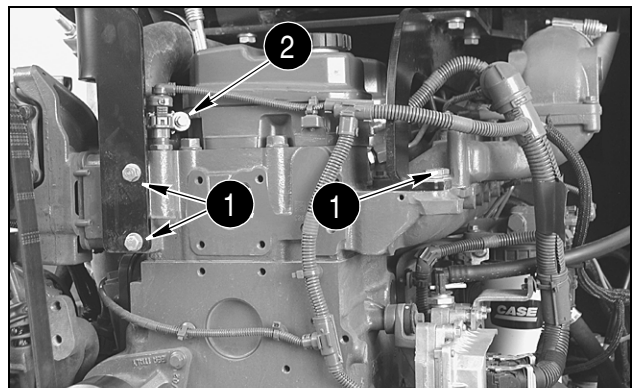

BD03A140

Install the four front muffler and air cleaner bracket mounting bolts (1). Install the upper coolant line and hose. Tighten the upper coolant line hose clamp (2) to a torque of 10.1 to 11.3 Nm (90 to 100 lb-inch).

**STEP 68**

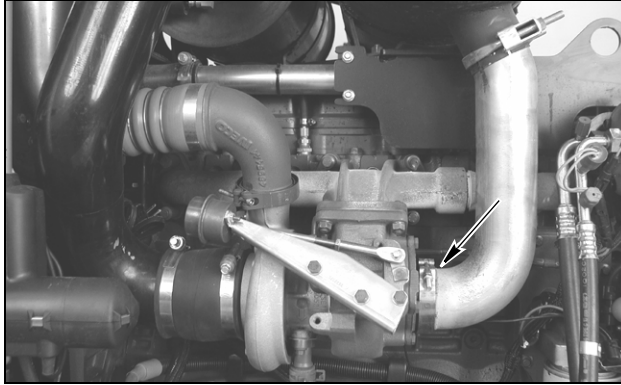

BD03A137

Install and tighten the exhaust clamp on the turbocharger.

**STEP 69**

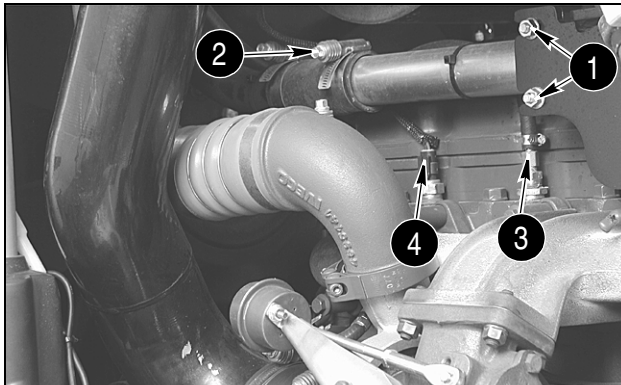

BD03A147

Install the coolant pipe support clamp, install washers two nuts (1) and tighten. Tighten the coolant pipe clamp (2) to a torque of 10.1 to 11.3 Nm (90 to 100 lb-inch). Connect the engine coolant vent line (3). Connect the coolant temperature sending unit (4). Remove and discard tag.

**STEP 70**

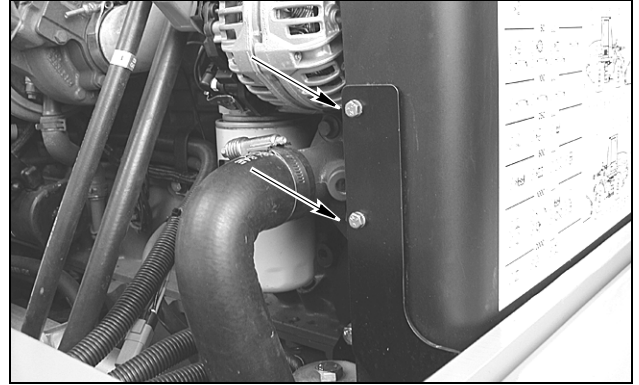

BD03A128

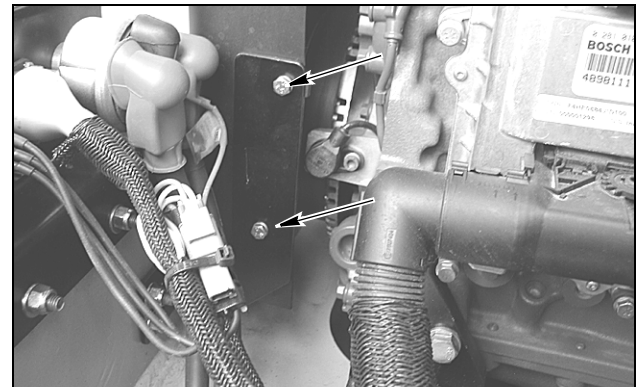

BD03A129

Install the cover mounting brackets to the machine frame. Install the belt cover, install the four mounting bolts for the belt cover.

**STEP 71**



BD03A118

Place the after cooler outlet hose on the machine. Tighten the clamp on the after cooler.

### STEP 72

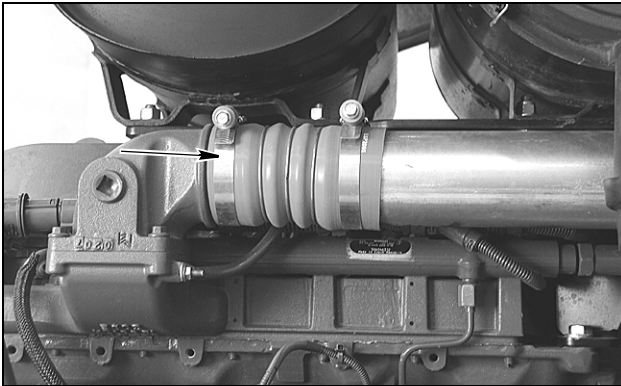

BD03A119

Tighten the clamp on the intake manifold for the after cooler output hose.

### STEP 73



BD03A115

Place the after cooler inlet hose on the machine. Tighten the clamp on the after cooler.

### STEP 74

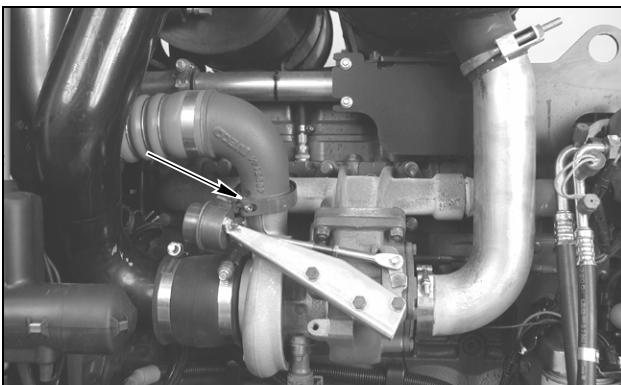

BD03A137

Tighten the clamp on the turbocharger for the after cooler inlet hose.

### STEP 75

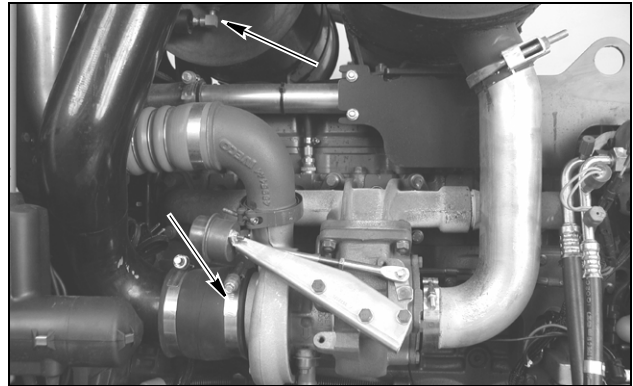

BD03A137

Install the intake hose and tighten the clamps on turbocharger and air cleaner.

### STEP 76

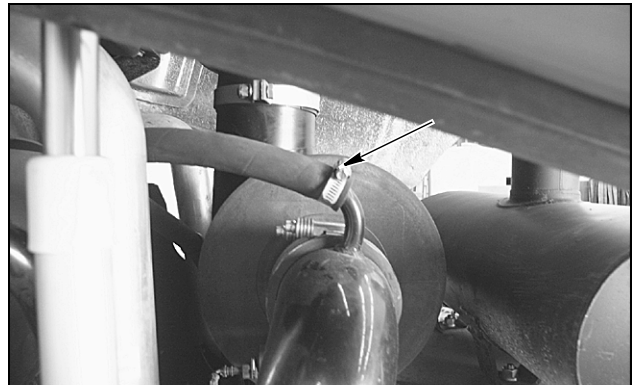

BD03A225

Install the crankcase ventilation hose and tighten the clamp on air cleaner intake hose.

### STEP 77

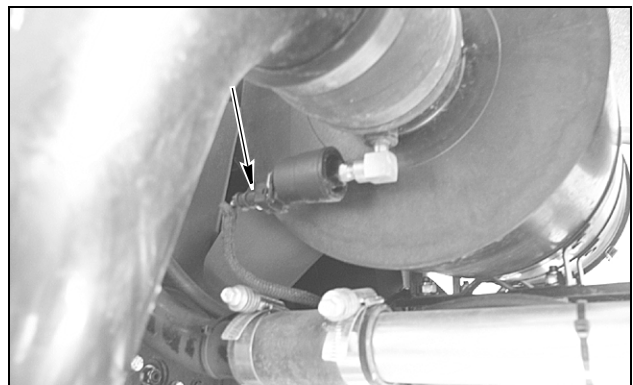

BD03A224

Connect engine wiring harness connector to air filter restriction switch. Remove and discard tag.

**STEP 78**



BD03A232

Carefully raise and place hood over loader.

**NOTE:** Refer to step 5 and 6 of removal for lifting procedure.

**STEP 79**



BD03A227

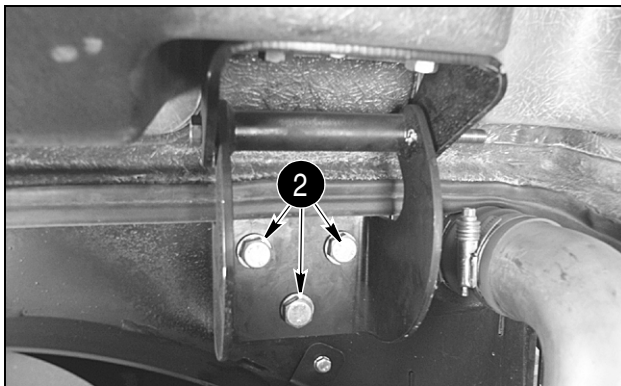

BD03A226

Have another person balance the hood, install the hood hinge mounting bolts (2) to the cooler frame. Install mount bolt (1) and backup alarm wiring harness clamp to cooler housing.

**STEP 80**

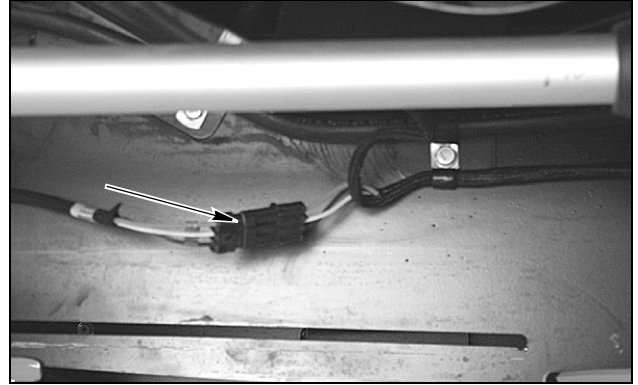

BD03A223

Connect hood wiring harness connector to rear chassis wiring harness connector. Remove and discard tag.

**STEP 81**

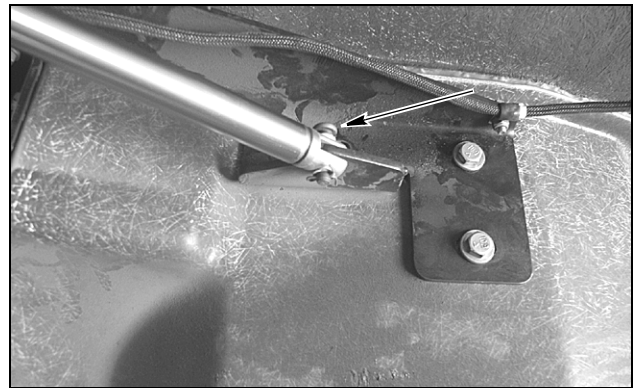

BD03A228

Install the pin from the top of the lifting motor, lower and remove lifting equipment.

**STEP 82**

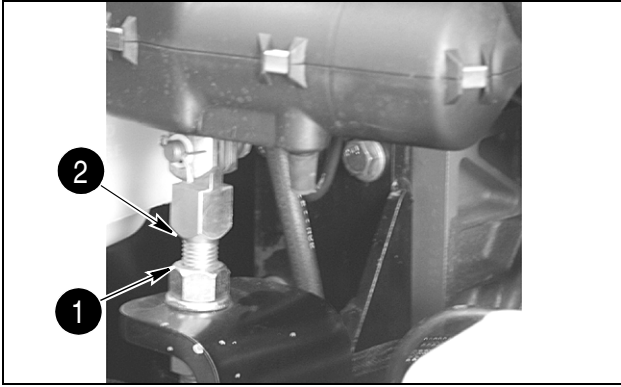

BD03A221

**NOTE:** If hood strut is not adjusted properly the hood will be damaged.

When a hood is removed and replaced an initial adjustment on the strut is necessary. Adjust between the top of the lift motor adjusting jam nut (1) to the top or the threads (2) to 20 mm (X). With the motor down to its lowest point take a measurement between the left hand side hood bumper and the counter weight, record this measurement (Y). Use the following table to adjust the strut (X).

721D Hood Adjustment Table							
Y (MM)	X (MM)	Y (MM)	X (MM)	Y (MM)	X (MM)	Y (MM)	X (MM)
1	19	21	14	41	9	61	5
2	19	22	14	42	9	62	5
3	18	23	14	43	9	63	4
4	18	24	13	44	9	64	4
5	18	25	13	45	9	65	4
6	18	26	13	46	8	66	4
7	17	27	13	47	8	67	3
8	17	28	12	48	8	68	3
9	17	29	12	49	8	69	3
10	17	30	12	50	7	70	3
11	16	31	12	51	7	71	2
12	16	32	12	52	7	72	2
13	16	33	11	53	7	73	2
14	16	34	11	54	6	74	2
15	16	35	11	55	6	75	2
16	15	36	11	56	6	76	1
17	15	37	10	57	6	77	1
18	15	38	10	58	6	78	1
19	15	39	10	59	5	79	1
20	14	40	10	60	5	80	0

**STEP 83**

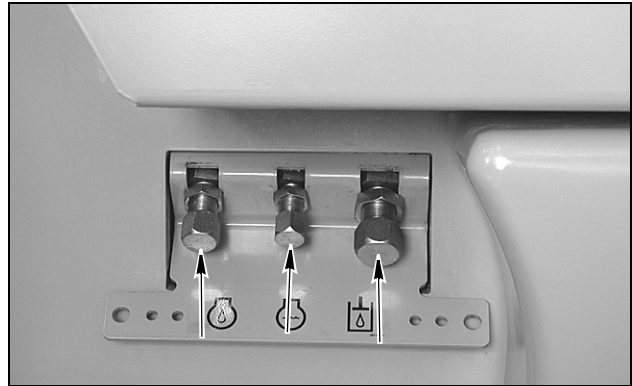

BD02N160

Check and make sure that drain caps are tight.

**STEP 84**

Install a new oil filter on engine. Fill engine with 14.2 liters (15 quarts) of Case AKCELA No. 1 Engine Oil (SAE 15W-40).

**STEP 85**

If hydraulic reservoir was drained, fill reservoir with 123 liters (32.5 gallons) of Case AKCELA Hy-Tran Ultra® fluid.

**STEP 86**

Fill engine coolant system with a solution of 50% Ethylene Glycol and 50% water. Cooling system capacity is 25.5 liters (6.75 gallons). Install the radiator cap. Fill the coolant reservoir up to the FULL mark on the reservoir.

**STEP 87**

Connect the batteries, install battery covers, put master disconnect switch in ON position.

**STEP 88**

Start engine and run the engine at low idle. Run the engine at operating temperature for approximately five minutes to completely mix the Ethylene Glycol and water. When the coolant is at operating temperature, stop the engine. When engine has cooled, check the coolant level at the reservoir.

**WARNING:** Hot coolant can spray out if radiator cap is removed. To remove radiator cap: Let system cool, turn to first notch, then wait until all pressure is released. Scalding can result from fast removal of radiator cap.

**STEP 89**

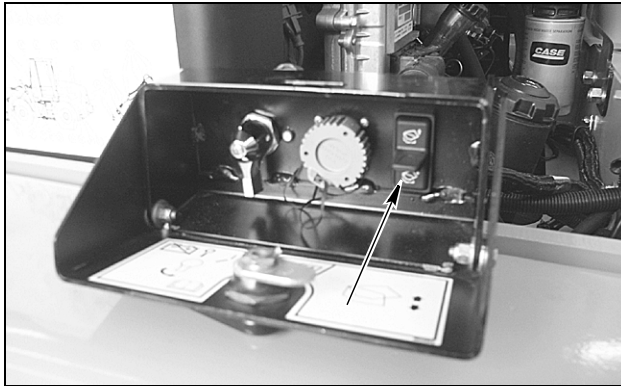

BD03A222

Lower the hood with the hood lift motor.

**STEP 90**

Put articulation lock in OPERATING position.

# RADIATOR

## Removal

### STEP 1

Park loader on level surface and lower bucket to ground. Apply parking brake and shut down engine.

### STEP 2

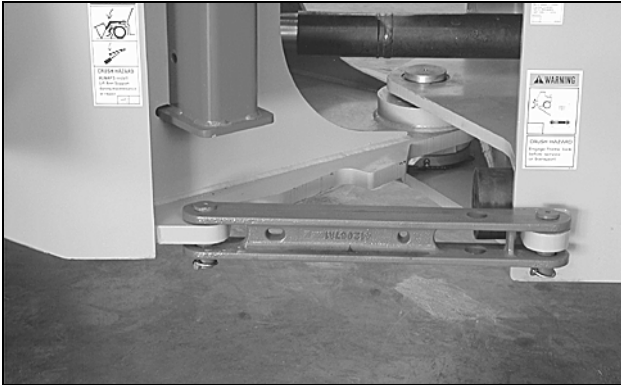

BD03A040

Put articulation lock in LOCKED position.

### STEP 3

Put master disconnect switch in OFF position.

### STEP 4

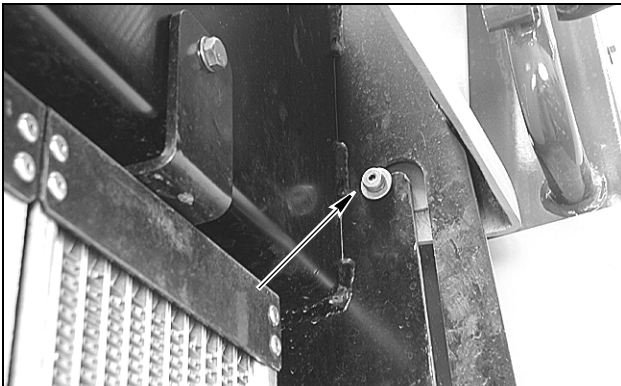

BD03A120

Have another person raise and hold the side panel up into the raised position. Remove the two mounting screws for the side panel, remove the panel.

**NOTE:** Photo is of the oil cooler side of the machine, the procedure is the same.

### STEP 5

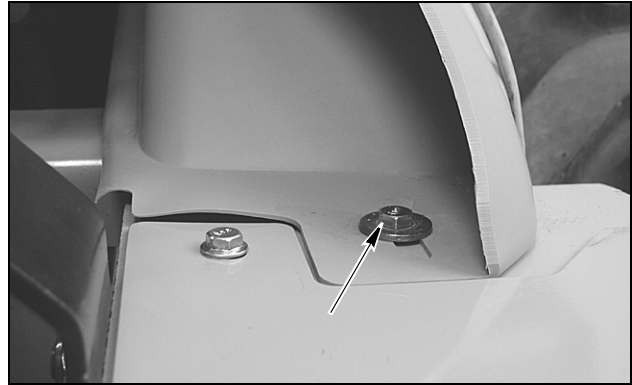

BD03A210



BD03A193

Remove two bolts and washers securing LH fender. Remove LH fender.

### STEP 6

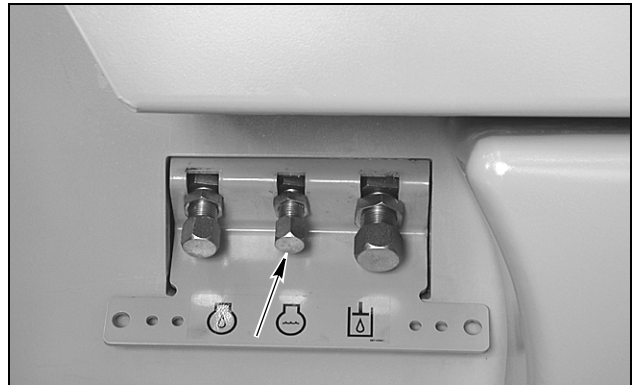

BD02N160

Put a 25.5 liter (6.75 gallon) container below radiator drain. Remove radiator cap then remove cap and drain coolant into container. Install cap after coolant has drained. Install radiator cap.

**STEP 7**

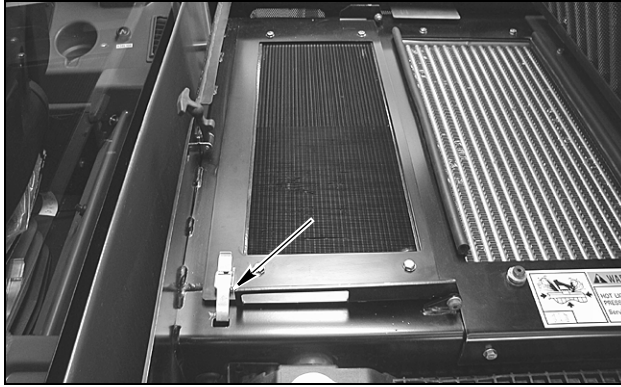

BD03A109

Release catch and tilt air conditioning condenser core up to gain access to upper radiator hose.

**STEP 8**

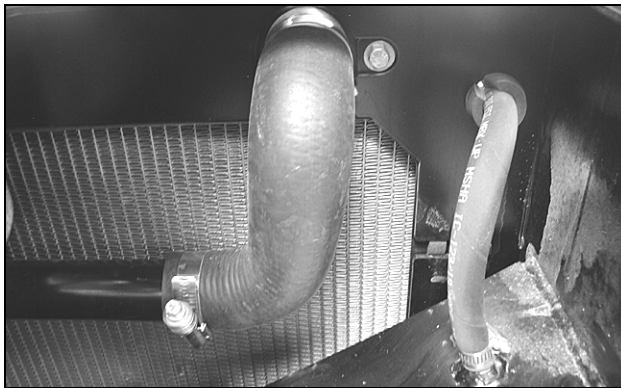

BD03A108

Loosen the upper radiator hose clamps, remove the hose.

**STEP 9**

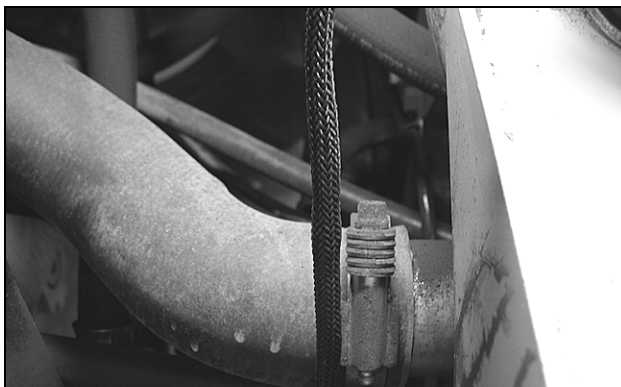

BD03A122

Loose and remove the lower radiator hose from the radiator.

**STEP 10**

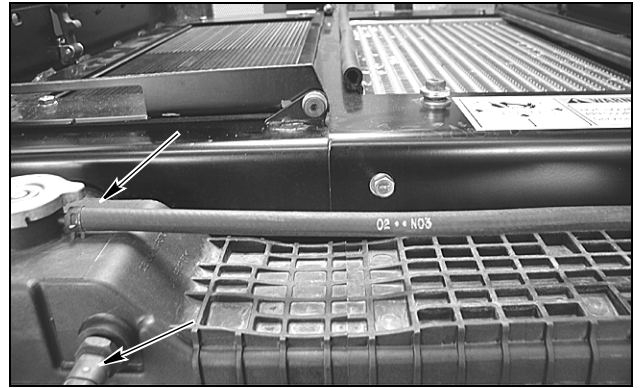

BD03A113

Disconnect overflow hose from radiator. Disconnect connector from coolant level sender.

**STEP 11**

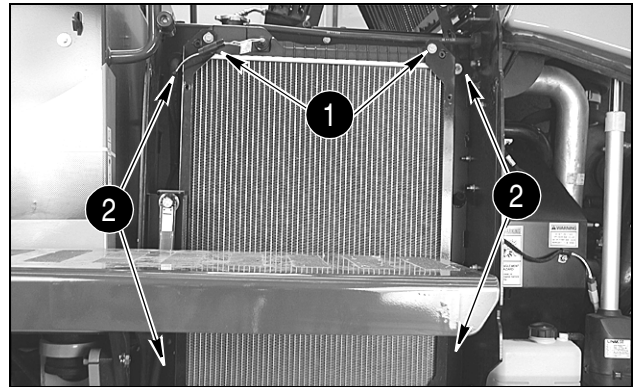

BD03A106

Remove screws and install lifting eyes (1). Attach suitable lifting equipment to lifting eyes. Remove four mounting bolts (2), remove radiator from machine.



**Suggest:**

**If the above button click is invalid.**

**Please download this document**

**first, and then click the above link**

**to download the complete manual.**

**Thank you so much for reading**

## Installation

### STEP 12

Move radiator into position above cooling frame. Carefully lower radiator while guiding it into position in cooling frame.

### STEP 13

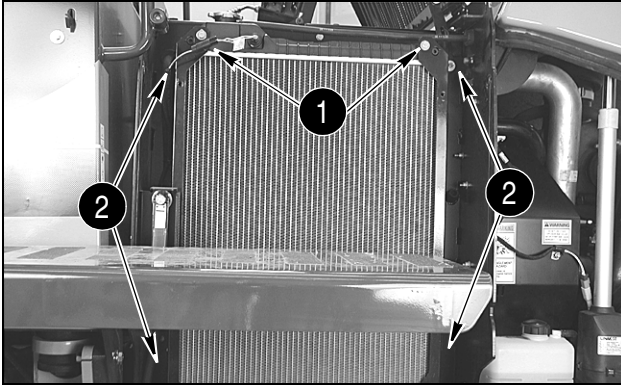

BD03A106

Install four lock washers and bolts (2) to secure radiator to cooling frame. Disconnect lifting equipment from lifting eyes. Remove lifting eyes and install screws (1).

### STEP 14

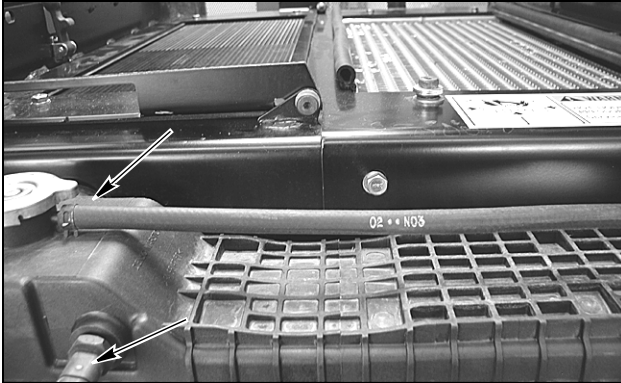

BD03A113

Connect connector to coolant level sender, connect overflow hose to radiator.

### STEP 15

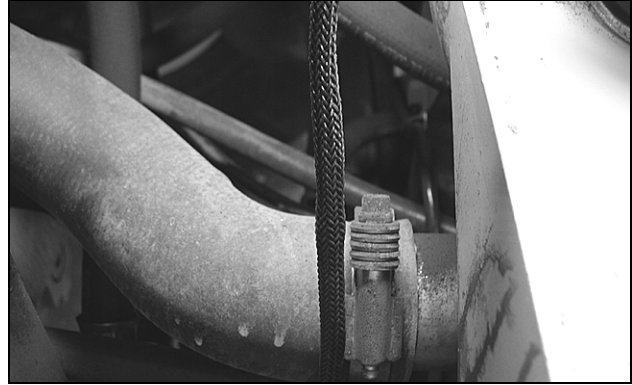

BD03A122

At bottom of radiator, install bottom radiator hose. Position and tighten two hose clamps to a torque of 10.1 to 11.3 Nm (90 to 100 lb-inch).

### STEP 16

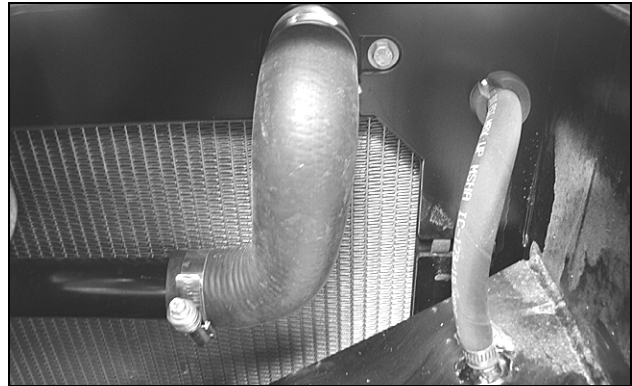

BD03A108

At top of cooling system frame, install hose. Position hose clamps and tighten to a torque of 10.1 to 11.3 Nm (90 to 100 lb-inch).

**<https://www.ebooklibonline.com>**

Hello dear friend!

Thank you very much for reading.

Enter the link into your browser.

The full manual is available for immediate download.

**<https://www.ebooklibonline.com>**