

1. Trim along dashed line.
2. Slide into pocket on Binder Spine.

TYPE 1-4

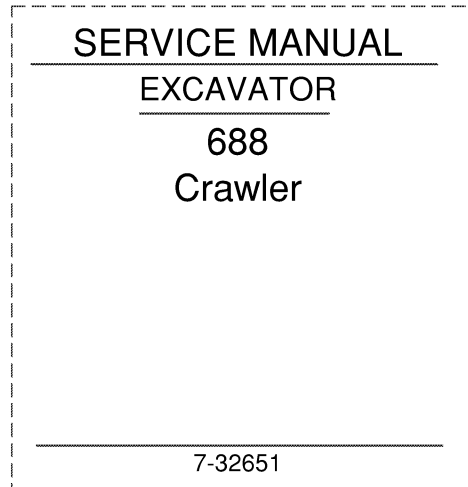

1. Trim along dashed line.
2. Slide into pocket on Binder Spine.

TYPE 1-4

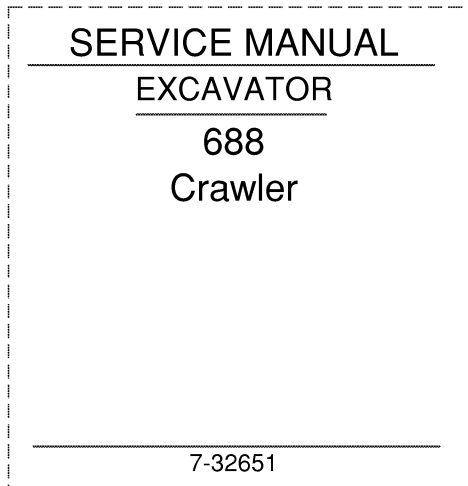

1. Trim along dashed line.
2. Slide into pocket on Binder Spine.

TYPE 1-4

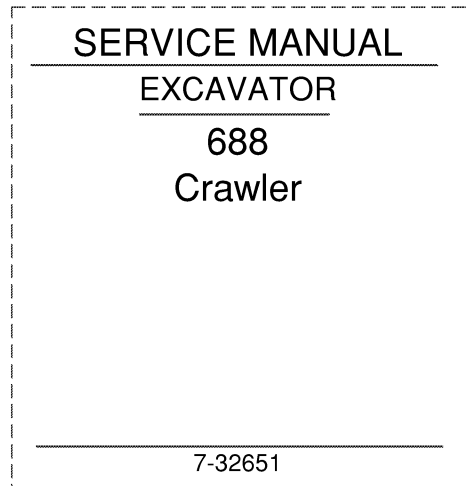

1. Trim along dashed line.
2. Slide into pocket on Binder Spine.

TYPE 1-4

688 Crawler Excavator

Table of Contents

	SECTION NO.	FORM NO.
1 GENERAL		
Sectional Index		7-32410
Safety, General Information and Torque Specifications	1001	8-86530
Specifications	1002	7-32351
2 ENGINE		
Sectional Index		7-32420
Engine Removal and Installation	2000	8-89000
Radiator and Oil Cooler	2001	8-89010
Cylinder Head and Valve Train	2415	8-24171
Cylinder Block	2425	8-24181
Lubrication System	2445	8-24191
Cooling System	2455	8-24201
Turbocharger	2465	8-25550
Turbocharger Failure Analysis	2565	9-78235
3 FUEL SYSTEM		
Sectional Index		7-32430
Fuel System and Filters	3410	8-24211
Fuel Injection Pump and Drive Gear	3412	8-27080
Fuel Injectors	3413	8-24231
4 ELECTRICAL		
Sectional Index		7-32440
Electrical Schematics and Troubleshooting	4001	8-89021
Battery Testing, Maintenance and Booster Battery Connections	4002	7-32080
Starter Motor	4003	8-89040
Alternator	4004	8-89050
5 TRACK		
Sectional Index		7-32470
Tracks, Rollers and Idlers	5002	7-32130
Track Troubleshooting	5502	7-33730
6 POWER TRAIN		
Sectional Index		7-32450
Drive Motor and Final Drive Transmission	6002	7-32290
Swing Motor and Reduction Gears	6003	7-32230

Reprinted

DON 8-88991 REPLACES DON 8-88990

CASE CORPORATION

Don 8-88991

Printed in England
May 1990

SECTION NO.

FORM NO.

8 HYDRAULICS

Sectional Index		7-32461
Hydraulic Troubleshooting	8001	8-89092
Low Pressure Pump	8002	8-89100
High Pressure Pump and Regulator	8003	8-89110
Attachment Valve Bank	8004	8-89130
Drive Control Valve	8005	7-32120
Option Control Valve	8006	7-32150
Counter Rotation Valve	8007	8-89150
Swing Brake Release Valve	8008	7-32170
Swing Control Valve	8009	7-32250
Anti-Surge Valve	8010	8-89160
Hydraulic Swivel	8011	7-32110
Drive Speed Limiter	8012	8-89230
Drive Brake Release Valve	8013	7-32190
Hand and Foot Valves	8015	8-89170
Hydraulic Oil Tank	8016	8-89080
Attachment Cylinders	8018	7-33600
Hydraulic Pick Hammer Control Valve	8222	7-34230

9 MOUNTED EQUIPMENT

Sectional Index		7-32471
Upperstructure and Turntable Bearing	9001	8-89140
Boom, Dipper and Bucket	9002	7-33620
Servicing the Cab	9004	7-32060

<https://www.ebooklibonline.com>

Hello dear friend!

Thank you very much for reading.

Enter the link into your browser.

The full manual is available for immediate download.

<https://www.ebooklibonline.com>

Section 1001

SAFETY, GENERAL INFORMATION
AND TORQUE SPECIFICATIONS

SAFETY

 *This symbol means ATTENTION! BECOME ALERT! YOUR SAFETY IS INVOLVED. The message that follows the symbol contains important information about safety. Carefully read the message. Make sure you fully understand the causes of possible injury or death.* 1 1 C

To prevent injury always follow the Warning, Caution and Danger notes in this section and throughout the manual.

Put the warning tag shown below on the key for the keyswitch when servicing or repairing the machine. One warning tag is supplied with each machine. Additional tags Part Number 331-4614 are available from your service parts supplier.





B004

 **WARNING:** Before starting engine, study Operator's Manual safety messages. Read all safety signs on machine. Clear the area of other persons. Learn and practice safe use of controls before operating. It is your responsibility to understand and follow manufacturers instructions on machine operation, service, and to observe pertinent laws and regulations. Operator's and Service Manuals may be obtained from your J.I. Case dealer 45 2

 **WARNING:** If you wear clothing that is too loose or do not use the correct safety equipment for your job, you can be injured. Always wear clothing that will not catch on objects. Extra safety equipment that can be required includes hard hat, safety shoes, ear protection, eye or face protection, heavy gloves and reflector clothing 45 3 A

 **WARNING:** Read the operator's manual to familiarize yourself with the correct control functions. 46 27

 **WARNING:** When working in the area of the fan belt with the engine running, avoid loose clothing if possible, and use extreme caution. 35 4

 **WARNING:** Operate the machine and equipment controls from the seat position only. Any other method could result in serious injury. 48 55

 **WARNING:** When doing checks and tests on the equipment hydraulics, follow the procedures as they are written. DO NOT change the procedure. 47 44

 **WARNING:** This is one man machine, no riders allowed. 35 8

 **WARNING:** When putting the hydraulic cylinders on this machine through the necessary cycles to check operation or to remove air from a circuit, make sure all people are out of the way. 47 45



WARNING: Use insulated gloves or mittens when working with hot parts.

8-11A



CAUTION: Lower all attachments to the ground or use stands to safely support the attachments before you do any maintenance or service.

8-11



CAUTION: Pin sized and smaller streams of hydraulic oil under pressure can penetrate the skin and result in serious infection. If hydraulic oil under pressure does penetrate the skin, seek medical treatment immediately. Maintain all hoses and tubes in good condition. Make sure all connections are tight. Make a replacement of any tube or hose that is damaged or thought to be damaged. **DO NOT** use your hand to check for leaks, use a piece of cardboard or wood.

8-11A



CAUTION: When removing hardened pins such as a pivot pin, or a hardened shaft, use a soft head (brass or bronze) hammer or use a driver made from brass or bronze and a steel head hammer.

8-12



CAUTION: When using a hammer to remove and install pivot pins or separate parts using compressed air or using a grinder, wear eye protection that completely encloses the eyes (approved goggles or other approved eye protectors).

8-13



CAUTION: Use suitable floor (service) jacks or chain hoist to raise wheels or tracks off the floor. Always block machine in place with suitable safety stands.

8-14



CAUTION: When servicing or repairing the machine. Keep the shop floor and operator's compartment and steps free of oil, water, grease, tools, etc. Use an oil absorbing material and or shop cloths as required. Use safe practices at all times.

8-16



CAUTION: Some components of this machine are very heavy. Use suitable lifting equipment or additional help as instructed in this Service Manual.

8-17



DANGER: Engine exhaust fumes can cause death. If it is necessary to start the engine in a closed place, remove the exhaust fumes from the area with an exhaust pipe extension. Open the doors and get outside air into the area.

8-18



DANGER: When the battery electrolyte is frozen, the battery can explode if (1) you try to charge the battery, or (2) you try to jump start and run the engine. To prevent the battery electrolyte from freezing, try to keep the battery at full charge. If you do not follow these instructions, you or others in the area can be injured.

8-19



DANGER: Batteries contain acid and explosive gas. Explosions can result from sparks, flames or wrong cable connections. To connect the jumper cables correctly to the battery of this machine see the Operator's Manual. Failure to follow these instructions can cause serious injury or death.

GENERAL INFORMATION

CLEANING

Clean all metal parts except bearings, in mineral spirits or by steam cleaning. Do not use caustic soda for steam cleaning. After cleaning dry, and put oil on all parts. Clean oil passages with compressed air. Clean bearings in kerosene, dry the bearings completely and put oil on the bearings.

INSPECTION

Check all parts when the parts are disassembled. Replace all parts that have wear or damage. Small scoring or grooves can be removed with a hone or crocus cloth. Complete visual inspection for indications of wear, pitting and the replacement of parts necessary will prevent early failures.

BEARINGS

Check bearings for easy action. If bearings have a loose fit or rough action replace the bearing. Wash bearings with a good solvent or kerosene and permit to air dry. **DO NOT DRY BEARINGS WITH COMPRESSED AIR.**

NEEDLE BEARINGS

Before you press needle bearings in a bore always remove any metal protrusions in the bore or edge of the bore. Before you press bearings into position put petroleum jelly on the inside and outside diameter of the bearings.

GEARS

Check all gears for wear and damage. Replace gears that have wear or damage.

OIL SEALS, O-RINGS AND GASKETS

Always install new oil seals, o-rings and gaskets. Put petroleum jelly on seals and o-rings.

SHAFTS

Check all shafts that have wear or damage. Check the bearing and oil seal surfaces of the shafts for damage.

SERVICE PARTS

Always install genuine Case service parts, when ordering refer to the Parts Catalog for the correct part number of the genuine Case replacement items. Failures due to the use of other than genuine Case replacement parts are not covered by warranty.

LUBRICATION

Only use the oils and lubricants specified in the Operator's or Service Manual. Failures due to the use of non specified oils and lubricants are not covered by warranty.

MODEL AND PIN NUMBERS

When ordering parts or when requesting information or assistance, always give the identification numbers of your machine.

Write the model and PIN numbers of your machine on the lines below.



C11414

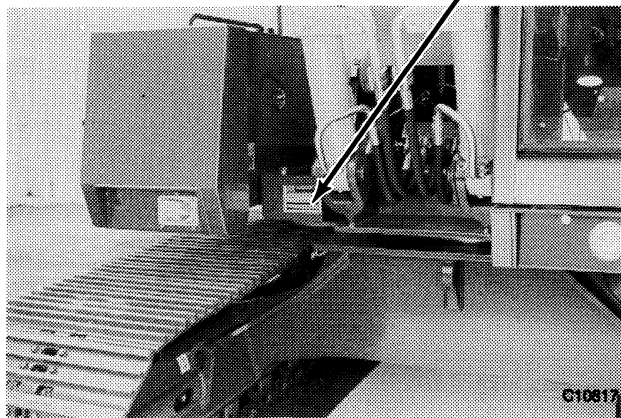

C10817

Machine Model Number _____

Machine PIN Number _____

Engine Serial Number _____

High Pressure Pump Serial Number _____

Low Pressure Pump Serial Number _____

Final Drive Serial Number:

Right Hand Side _____

Left Hand Side _____

Section 2000

ENGINE REMOVAL AND INSTALLATION

For 688 Crawler Excavators

2000

Removal



WARNING: When the machine is operating, the engine systems and the hydraulic pump systems heat up to a high temperature. To avoid the possibility of being burnt by hot metal or scalded by hot oil or water, allow the machine to cool before starting any maintenance work.

STEP 1

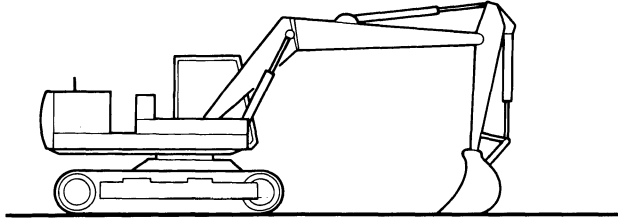

EA2836

Put the machine on level ground. Lower the attachment to the ground. Stop the engine and allow the systems to cool.

STEP 2

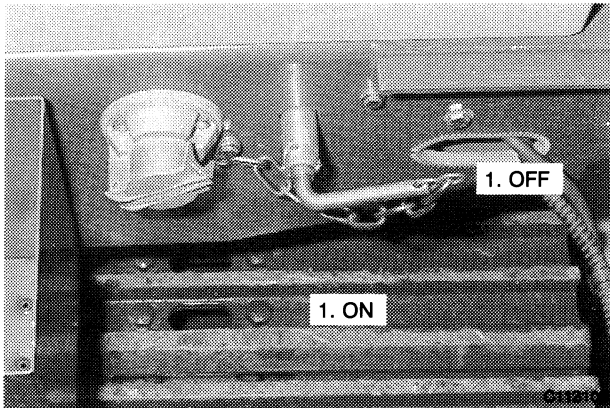

C11210

Turn the master disconnect switch, located under the right-hand side of the walkway, to the OFF position and remove the key.

STEP 3

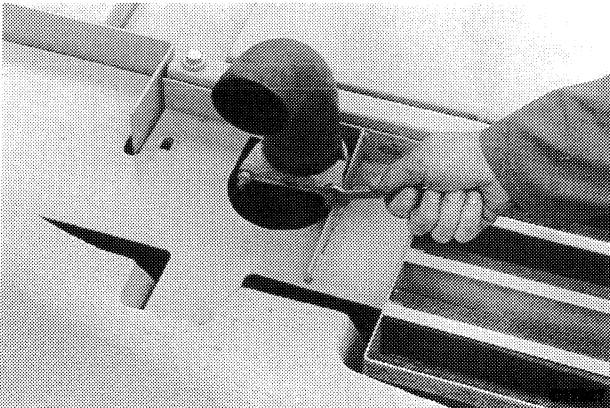

Loosen the nuts on the exhaust muffler extension tube. Remove the exhaust muffler extension tube.

STEP 4

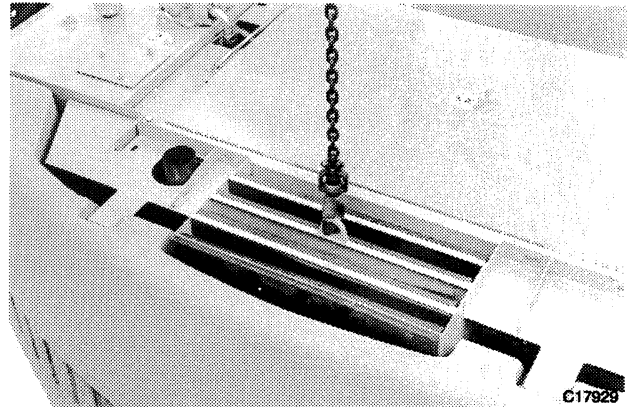

C17929

Install suitable lifting equipment onto the engine insulator. Remove the engine insulator mounting bolts and spacers and remove the engine insulator.

STEP 5

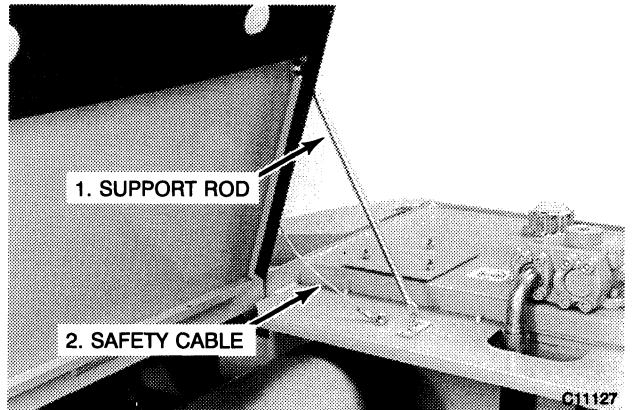

C11127

Raise the engine upper access cover and install the support rod. Remove the engine front cover. Remove the safety cable retaining bolt, spacers and nut. Lower the engine upper access cover.

STEP 6

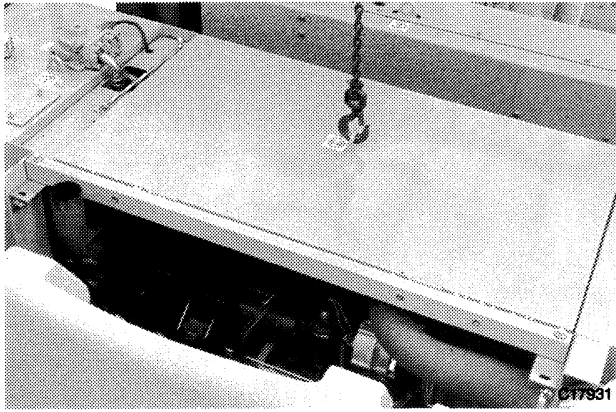

Install suitable lifting equipment on the engine upper access cover. Remove the retaining bolts, spacers and nuts and remove the engine upper access cover.

WARNING: Hot engine coolant can spray out of the radiator when the radiator cap is removed. To remove the radiator cap, allow the engine cooling system to cool. Turn the radiator cap to the first notch and wait until the pressure is released. Then remove the radiator cap.

STEP 7

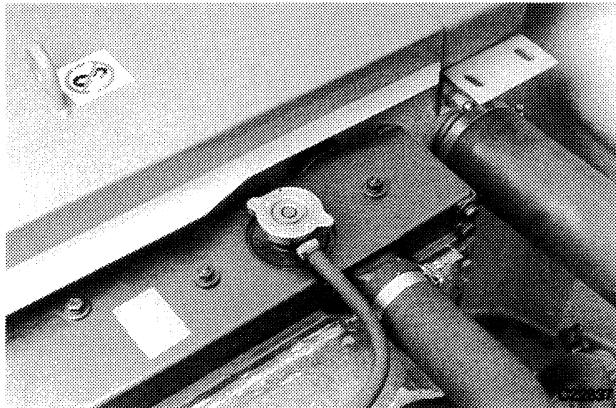

Remove the radiator cap.

STEP 8

Remove the access panels under the engine and under the hydraulic oil tank.

STEP 9

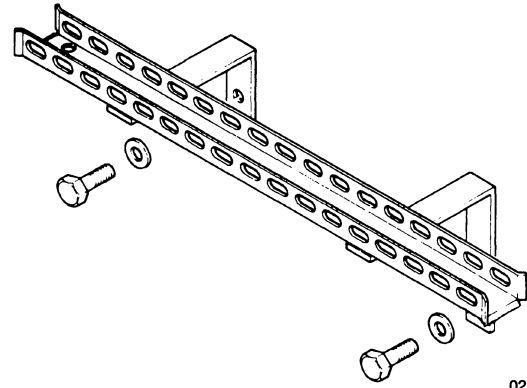

Remove the mounting bolts and spacers and remove the wiring harness carrier from the rear of the engine.

STEP 10

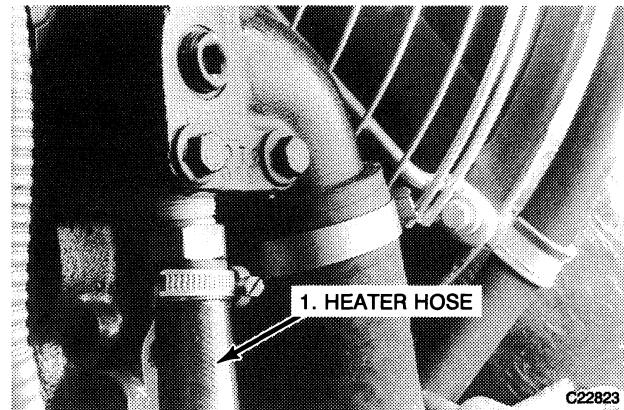

Put a clean container of at least 14 litres (3.7 US gallons) under the engine. Remove the heater hose from the engine and drain engine coolant into the container.

STEP 11

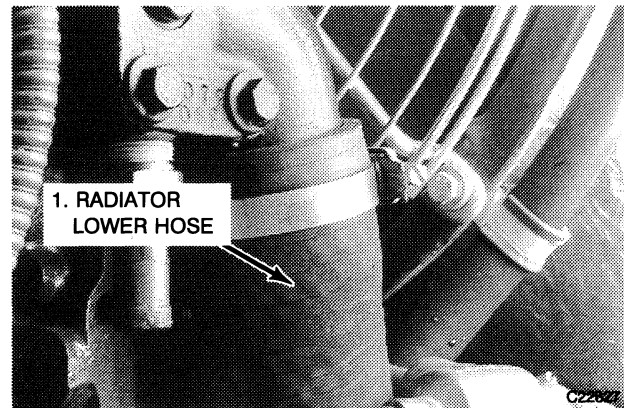

Remove the radiator lower hose and drain the remaining engine coolant into the container.

STEP 12

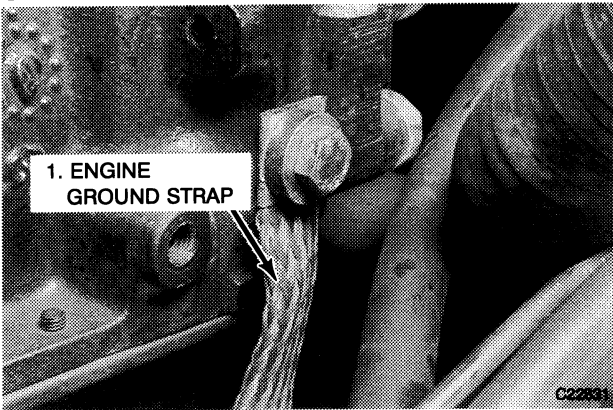

Remove the retaining bolt and spacer and remove the engine ground strap.

STEP 13

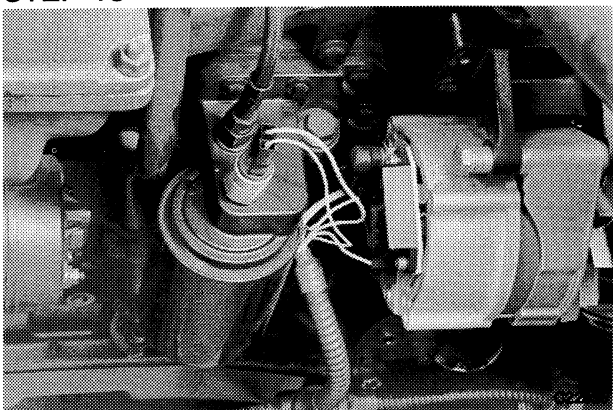

Disconnect the wires from the oil filter.

STEP 14

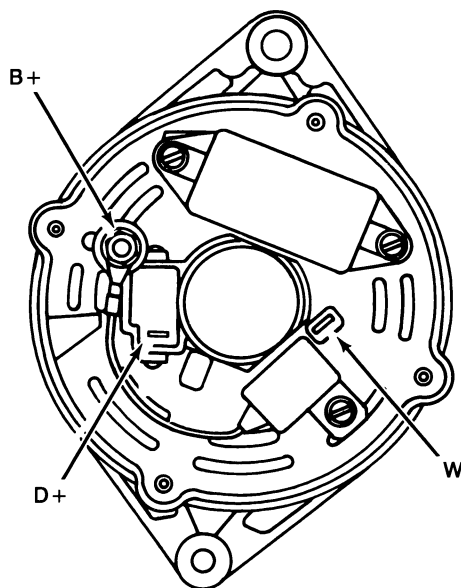

Disconnect the wires from the alternator.

STEP 15

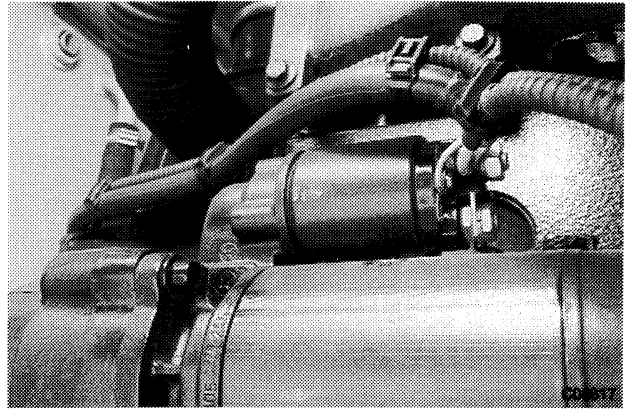

Disconnect the wires from the starter motor.

STEP 16

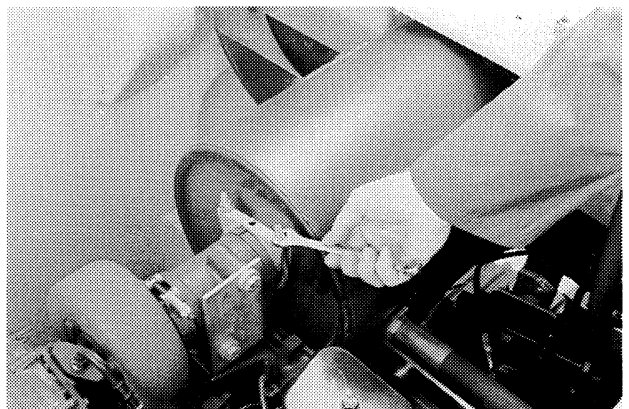

Loosen the nuts on the exhaust muffler clamp.

STEP 17

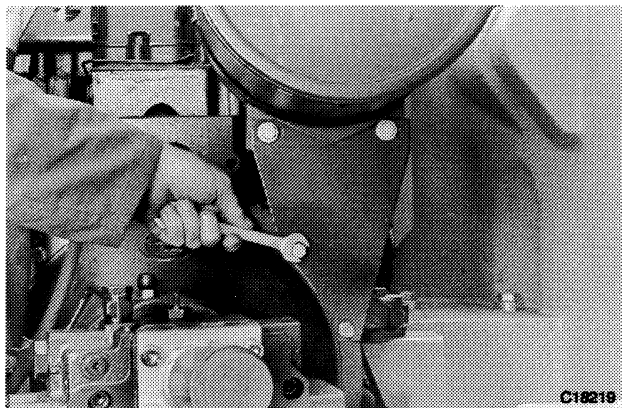

Remove the mounting bolts and spacers. Remove the exhaust muffler and bracket.

STEP 18

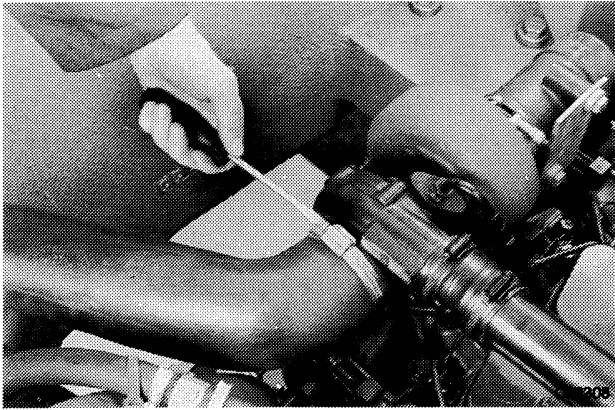

Disconnect the air inlet hose from the engine and from the air filter assembly.

STEP 19

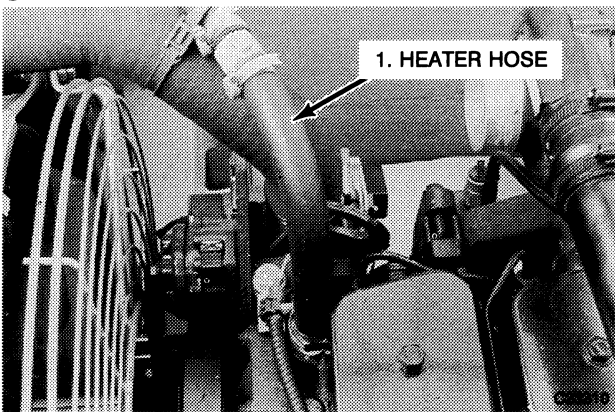

Disconnect the heater hose from the engine.

STEP 20

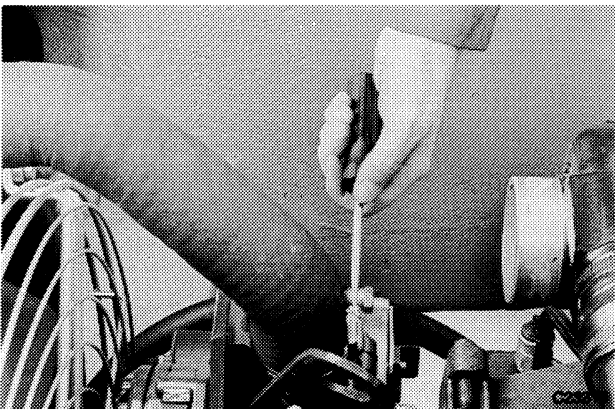

Disconnect the radiator upper hose from the engine and from the radiator.

STEP 21

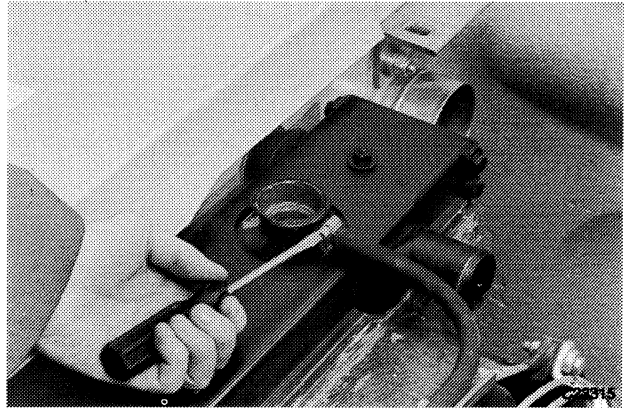

Disconnect the radiator overflow hose.

STEP 22

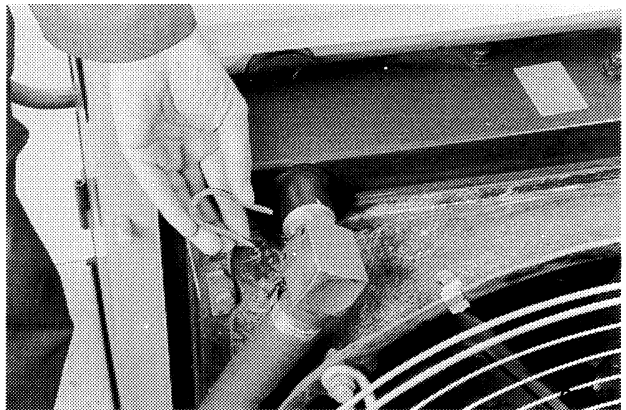

Remove the clip and disconnect the oil cooler upper hose from the oil cooler. Cap the oil cooler and the hose.

STEP 23

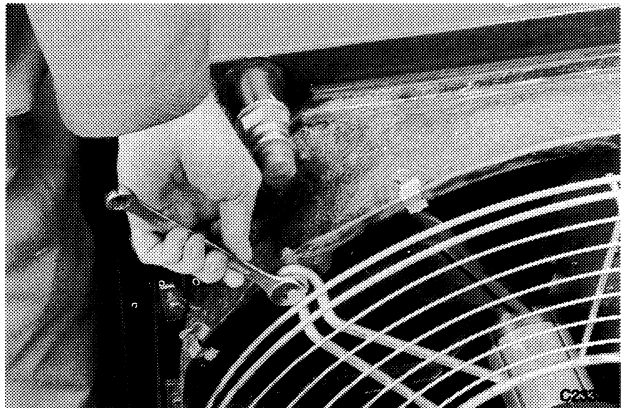

Remove the mounting bolts, spacers and nuts and remove the fan guard.

STEP 24

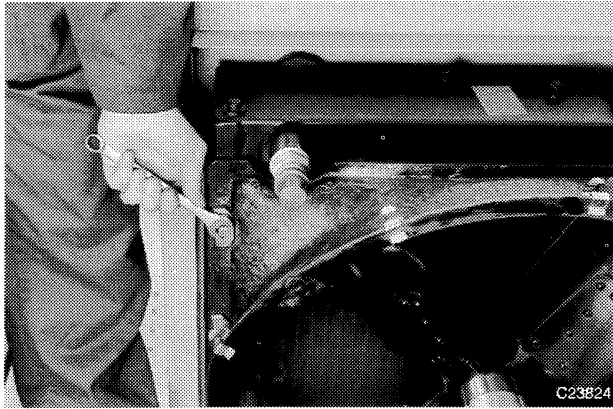

Remove the mounting bolts and spacers and move the fan shroud towards the engine.

STEP 25

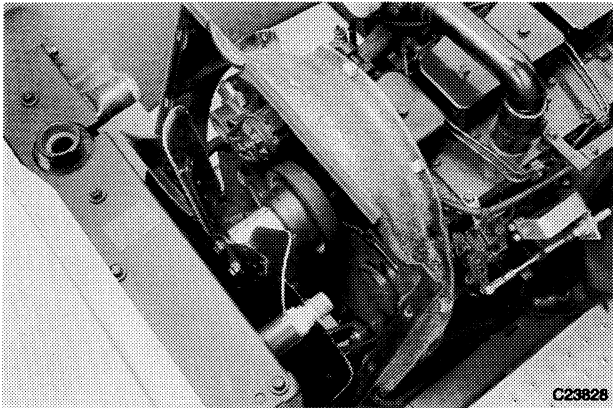

Remove the fan mounting bolts and washers. Remove the fan, the fan spacer and the fan shroud.

STEP 26

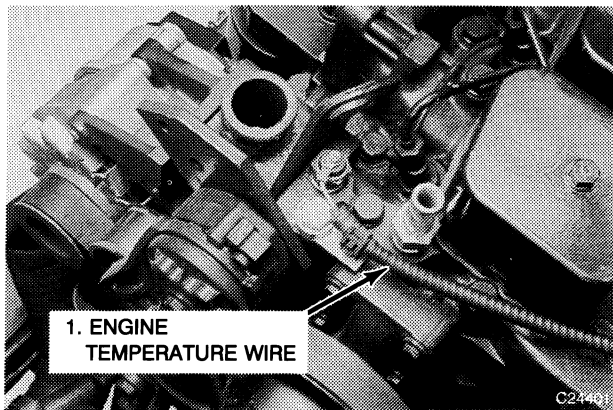

Disconnect the engine temperature wire.

STEP 27

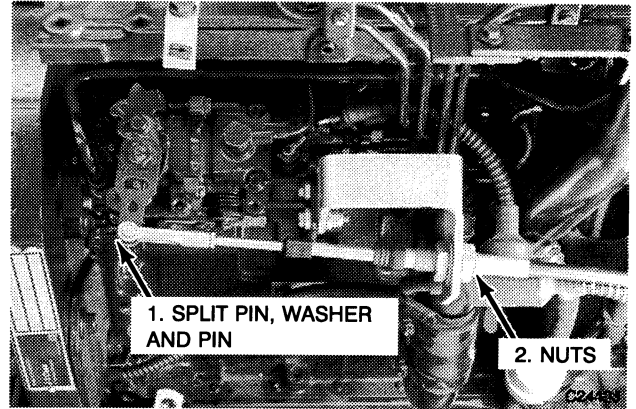

Remove the split pin, washer and pin that hold the throttle cable onto the fuel injection pump lever. Loosen the nuts that hold the throttle cable in the bracket and remove the throttle cable from the engine.

STEP 28

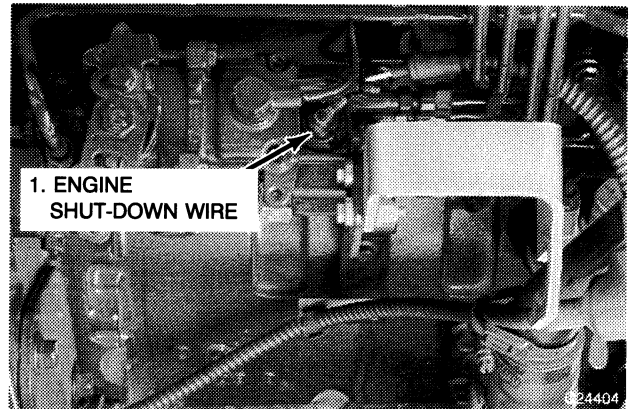

Disconnect the engine shut-down wire.

STEP 29

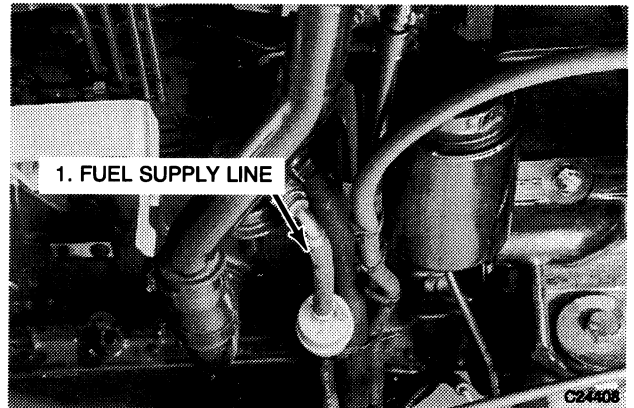

Disconnect and cap the fuel supply line.

STEP 30

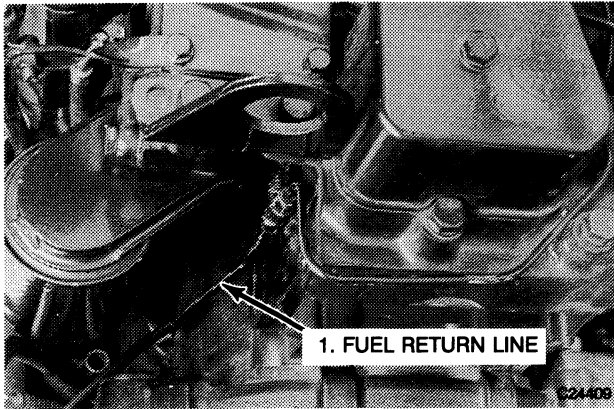

Disconnect and cap the fuel return line from the tee assembly and from the engine.

STEP 31

Disconnect the crankcase breather hose.

STEP 32

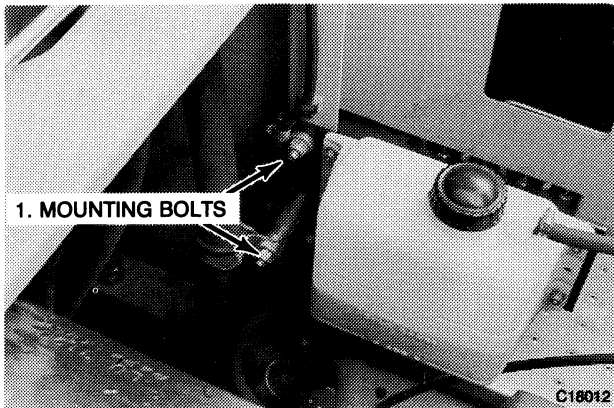

Disconnect the hoses from the top and the bottom of the coolant recovery reservoir. Remove the mounting bolts, spacers and nuts and remove the coolant recovery reservoir.

STEP 33

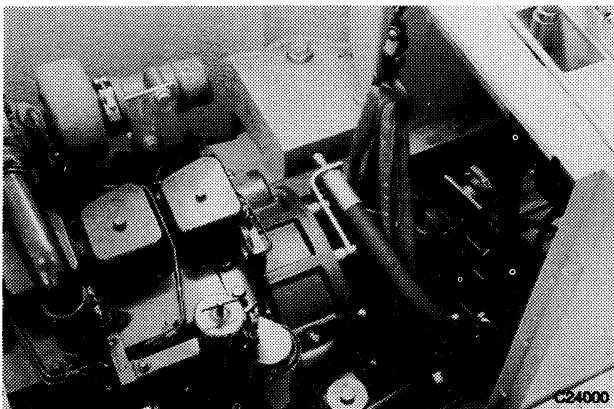

Install suitable lifting equipment to support the hydraulic pump when the engine is removed.

STEP 34

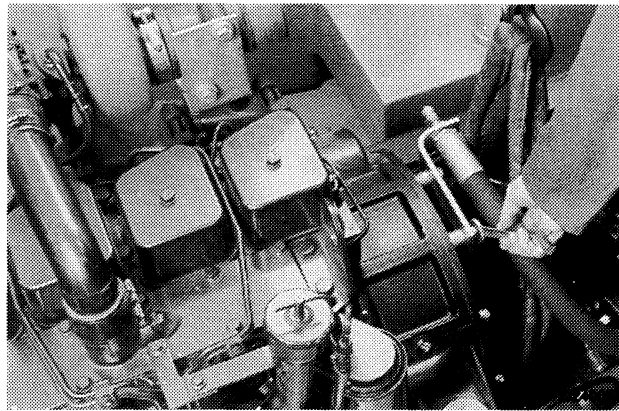

Remove the hydraulic pump mounting bolts and spacers and remove the pressure check hose and bracket. Remove the remaining hydraulic pump mounting bolts and spacers.

STEP 35

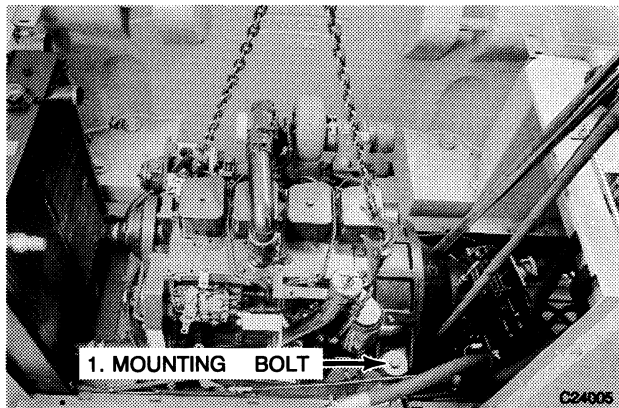

Install suitable lifting equipment onto the engine lifting eyes. Remove the engine mounting bolts, washers, spacers and nuts.

NOTE: *The engine weighs approximately 450 kg (990 lb).*

STEP 36

Lift the engine free of the mountings and move towards the radiator until it is free from the hydraulic pump coupling. Carefully remove the engine from the machine.

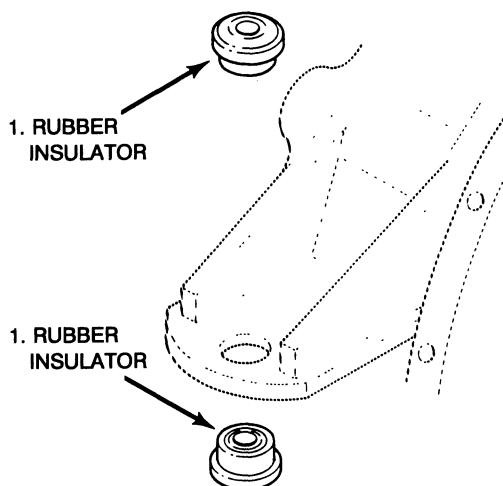
STEP 37

02165

Inspect the rubber insulators for wear or damage and replace if necessary.

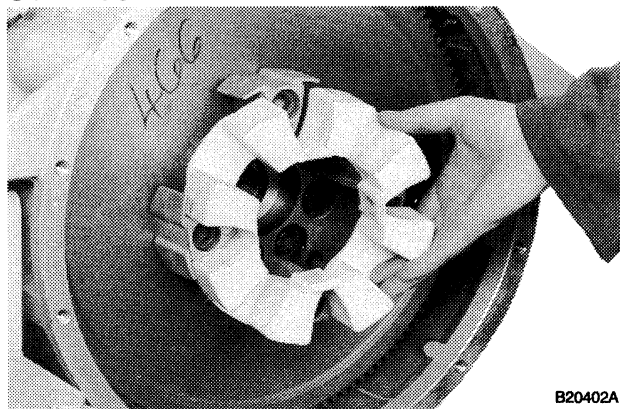
STEP 38

B20402A

Inspect the hydraulic pump shock-absorber for wear or damage and replace if necessary.

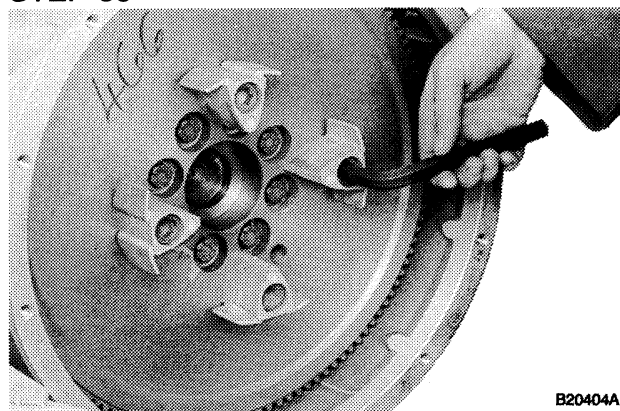
STEP 39

B20404A

Remove the shock-absorber centering-mount bolts, and remove the shock-absorber centering-mounts. Inspect the shock-absorber centering-mounts for wear or damage and replace if necessary.

Installation

STEP 40

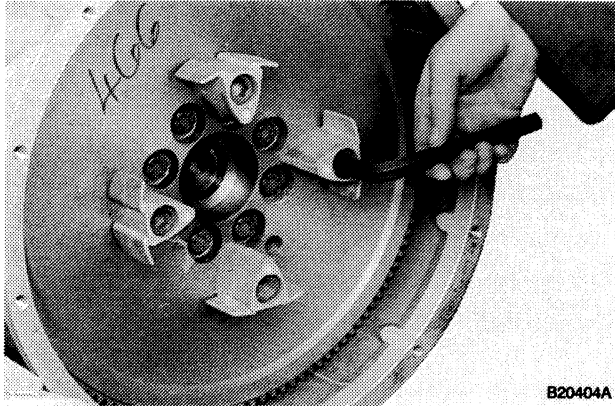

Clean the shock-absorber centering mount bolts and bolt holes. Apply Loctite 638 to the shock-absorber centering-mount bolts. Install the shock-absorber centering-mounts and bolts. Do not fully tighten the bolts.

STEP 41

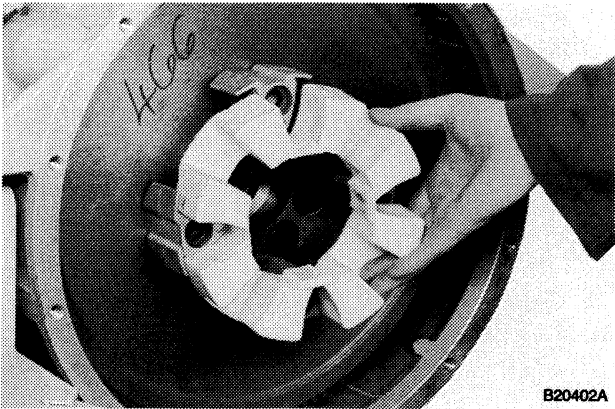

1. INCORRECT

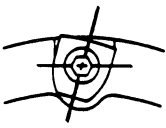

2. CORRECT

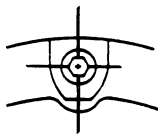

0216R

Install the shock-absorber. Make sure that the shock-absorber centering-mounts are centered in the shock-absorber and tighten the bolts to a torque of 220 Nm (162 lb ft).

STEP 42

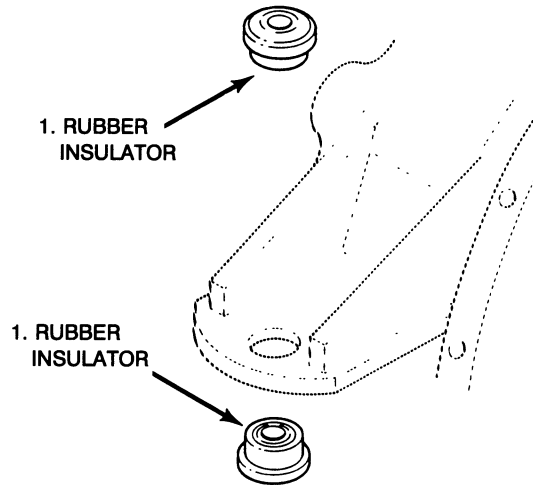

0216S

Install the upper and lower rubber insulators. The insulators are a tight fit in the engine supports.

STEP 43

Lift the engine into the engine compartment and connect the engine to the hydraulic pump, making sure that the hydraulic pump drive coupling engages correctly.

STEP 44

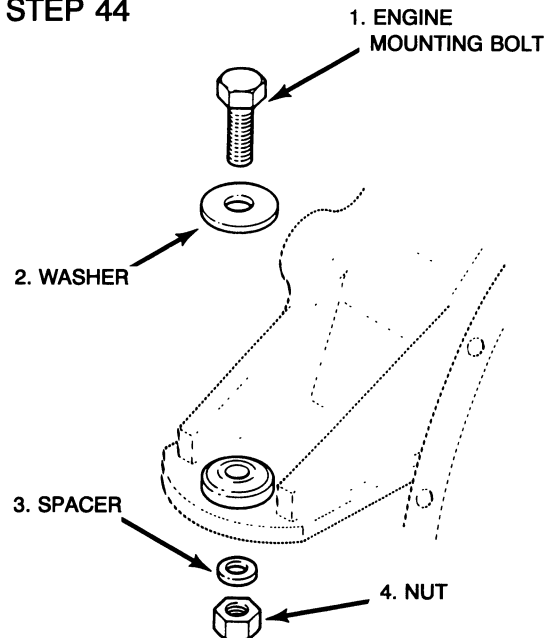

0216T

Install the engine mounting bolts, washers, spacers and nuts. Tighten the engine mounting bolts to a torque of 217 to 271 Nm (160 to 200 lb ft). Remove the lifting equipment from the engine.

STEP 45

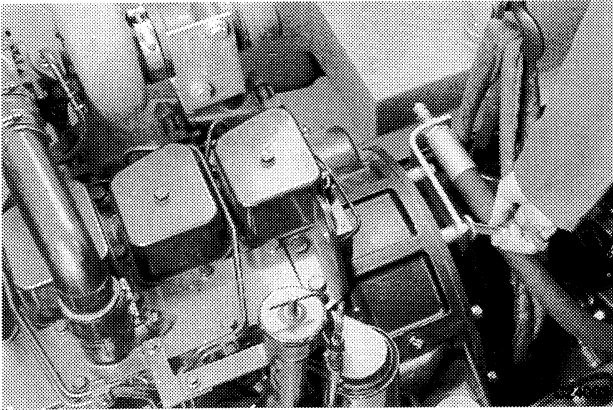

Install the pressure check hose and bracket. Install the hydraulic pump mounting bolts and spacers and tighten to a torque of 44 Nm (32.5 lb ft). Remove the lifting equipment from the hydraulic pump.

STEP 46

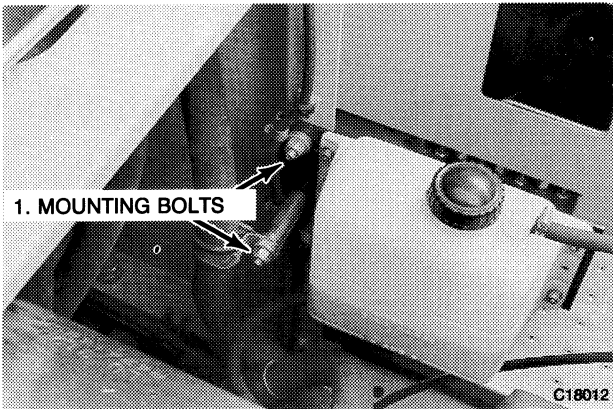

Install the coolant recovery reservoir and install and tighten the mounting bolts, spacers and nuts. Connect the hoses to the top and the bottom of the coolant recovery reservoir and tighten the clamps.

STEP 47

Connect the crankcase breather hose.

STEP 48

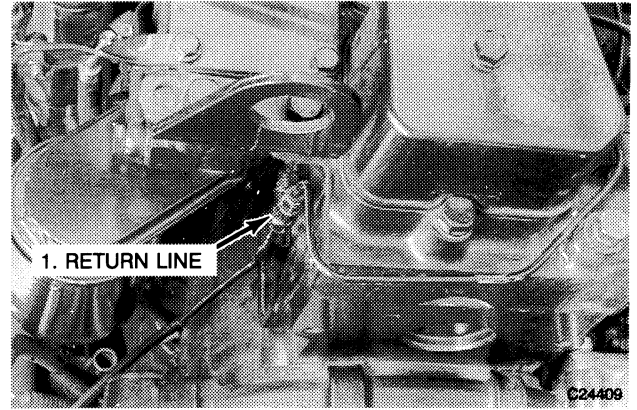

Connect the fuel return line to the tee assembly. Install and tighten the retaining bolt and washers.

STEP 49

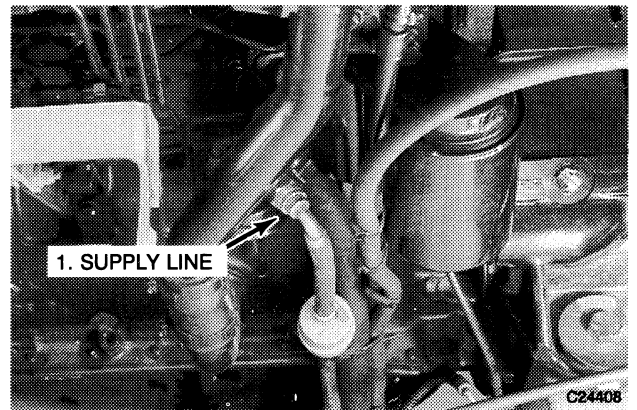

Connect the fuel supply line.

STEP 50

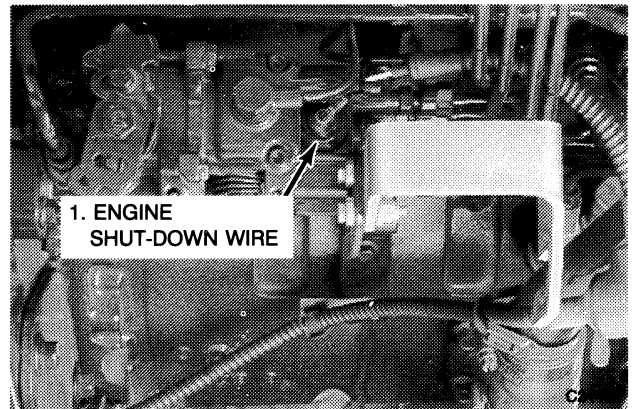

Connect the engine shut-down wire.

STEP 51

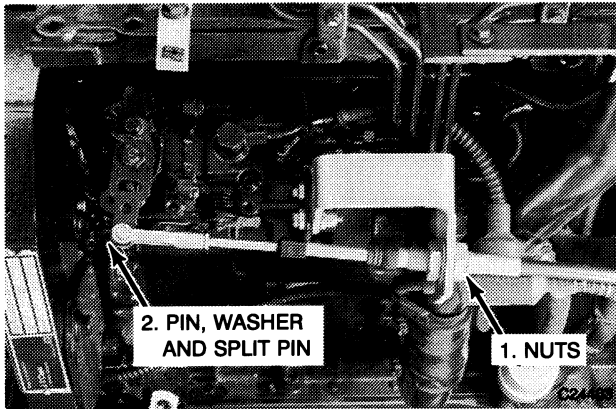

Install the throttle cable in the bracket and tighten the nuts. Install the throttle cable in the fuel injection pump lever and install the pin, washer and split pin.

STEP 52

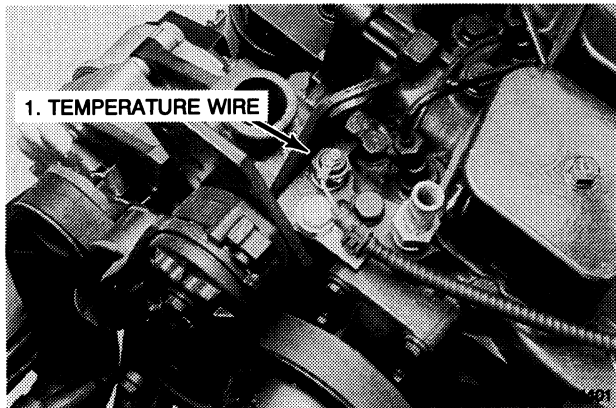

Connect the engine temperature wire.

STEP 53

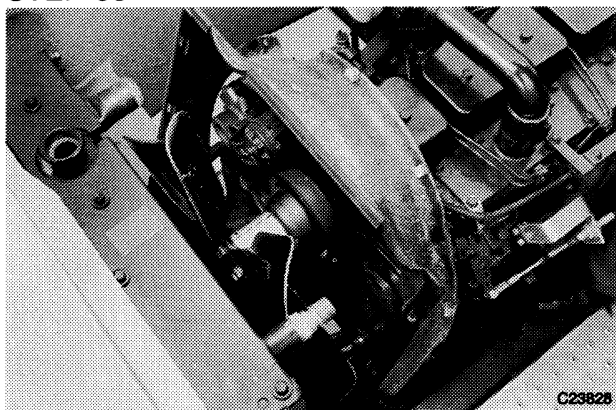

Install the fan shroud, but do not install the mounting bolts and spacers. Install the fan spacer and the fan. Install and tighten the fan mounting bolts and washers to a torque of 43 Nm (32 lb ft).

STEP 54

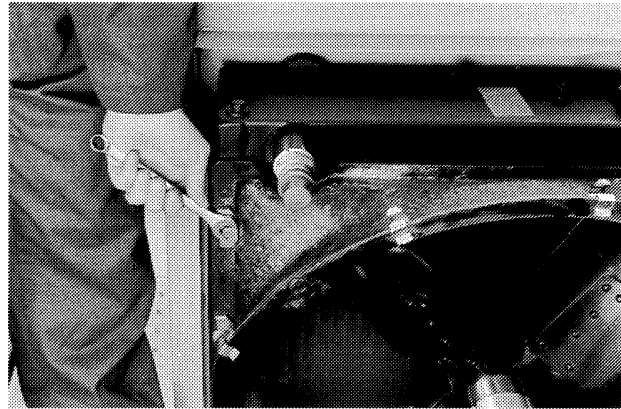

Install and tighten the fan shroud mounting bolts and spacers.

STEP 55

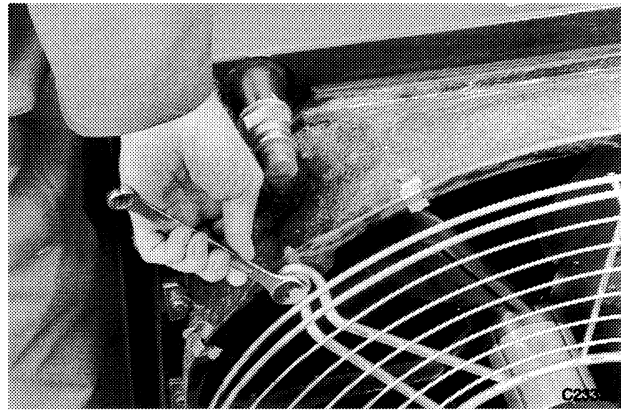

Install the fan guard. Install and tighten the mounting bolts, spacers and nuts.

STEP 56

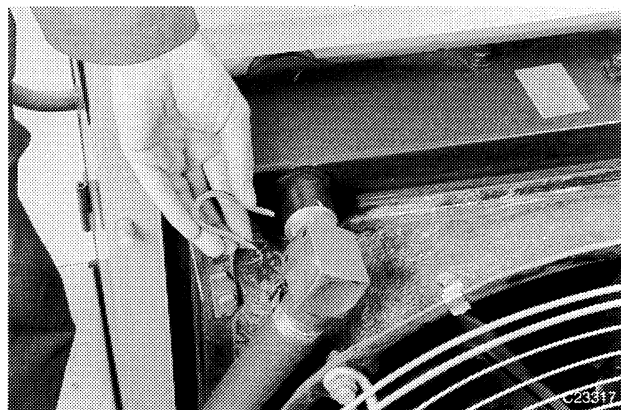

Install the oil cooler upper hose and install the clip.

STEP 57

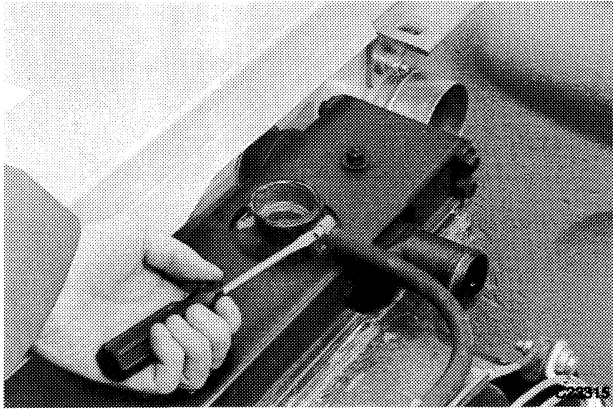

Install the radiator overflow hose and tighten the clamp.

STEP 58

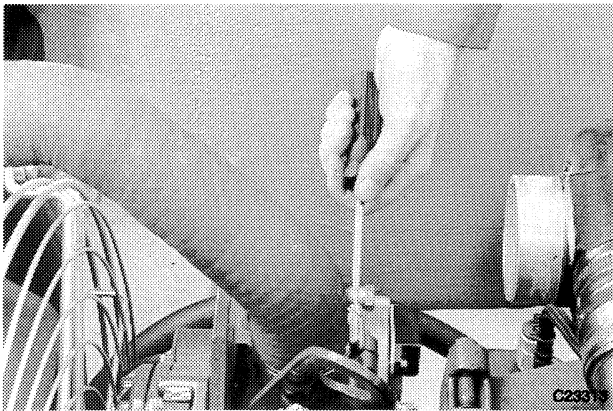

Install the radiator upper hose and tighten the clamps.

STEP 59

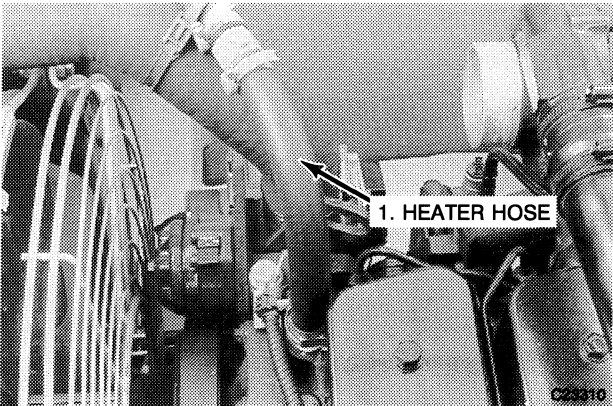

Install the heater hose and tighten the clamp.

STEP 60

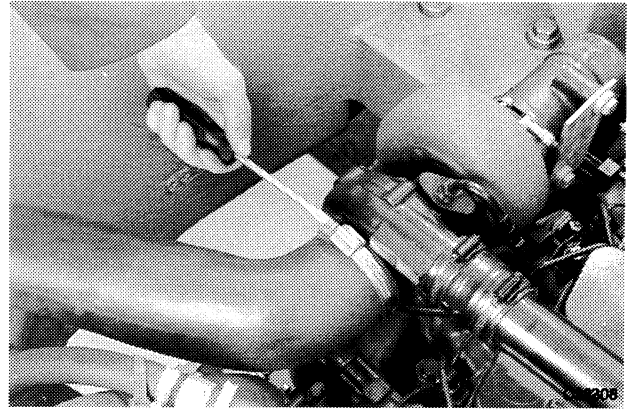

Install the air inlet hose and tighten the clamps.

STEP 61

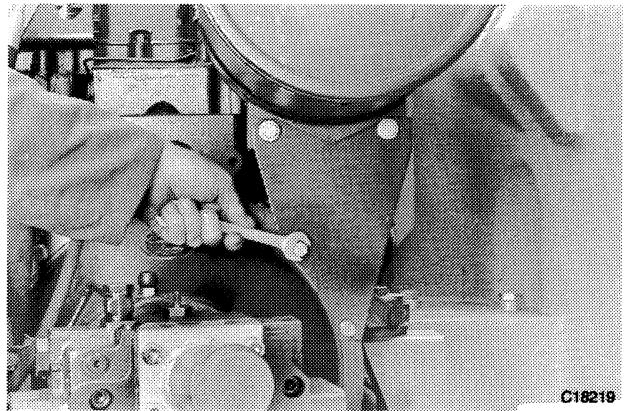

Install the exhaust muffler and bracket. Install the mounting bolts and spacers and tighten to a torque of 44 Nm (32.5 lb ft).

STEP 62

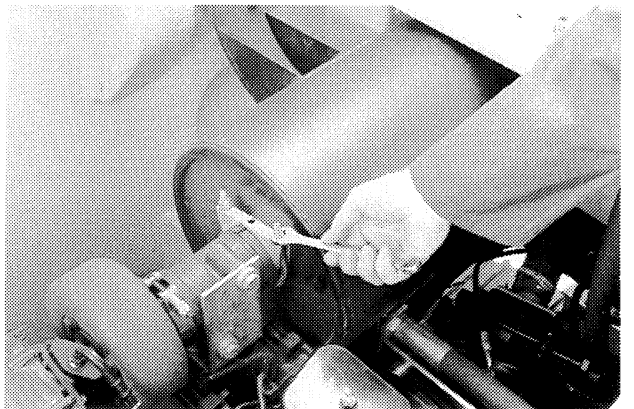

Install the exhaust muffler clamp and tighten the nuts.

STEP 63

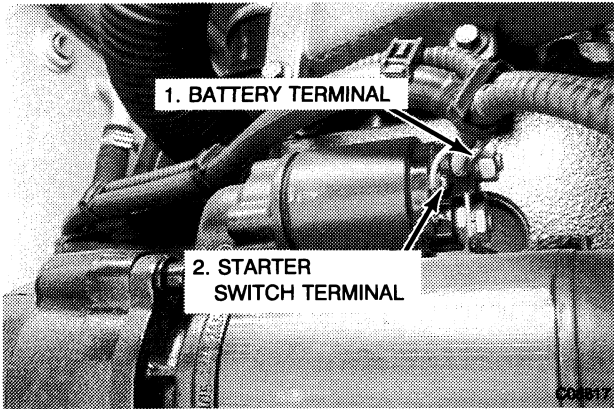

Install the battery cable and wire number 2 on the battery terminal. Install and tighten the washer and nut. Install wire number 4 on the starter switch terminal. Install and tighten the washer and screw.

STEP 64

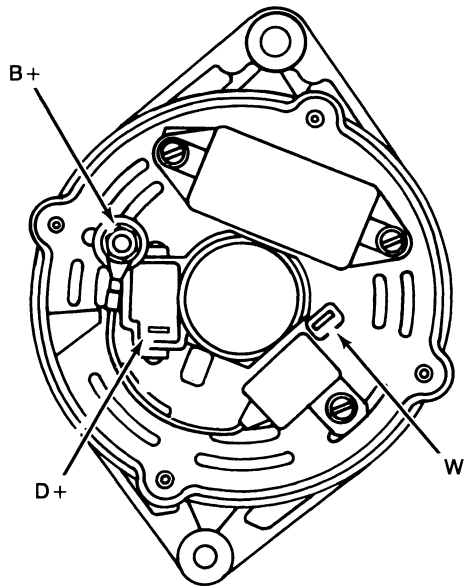

Make sure the capacitor wire is installed on the B+ terminal. Install wire number 2 on the B+ terminal and install and tighten the nut. Connect wire number 13 to the D+ terminal. Connect wire 14 to W terminal.

STEP 65

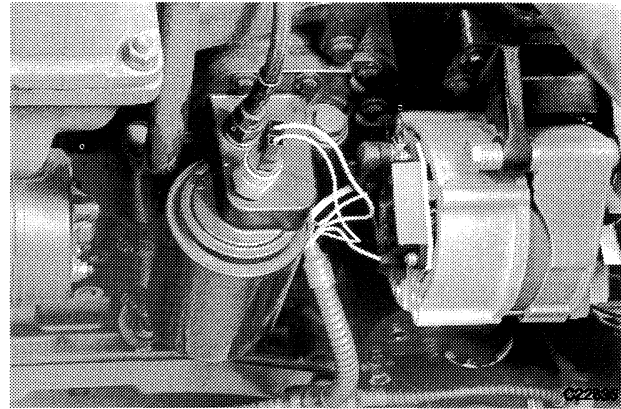

Connect wires number 23 and 0 to the oil filter.

STEP 66

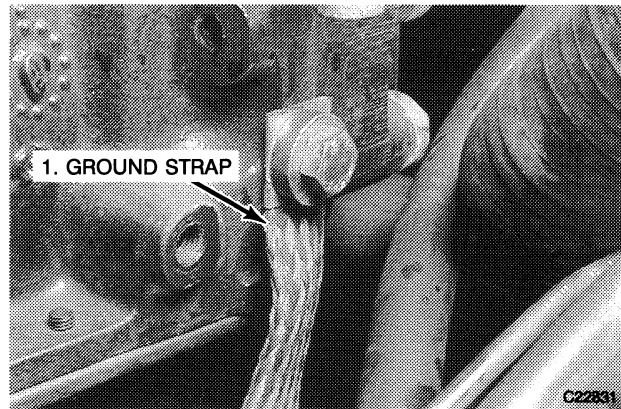

Install the engine ground strap and install and tighten the retaining bolt and spacer.

STEP 67

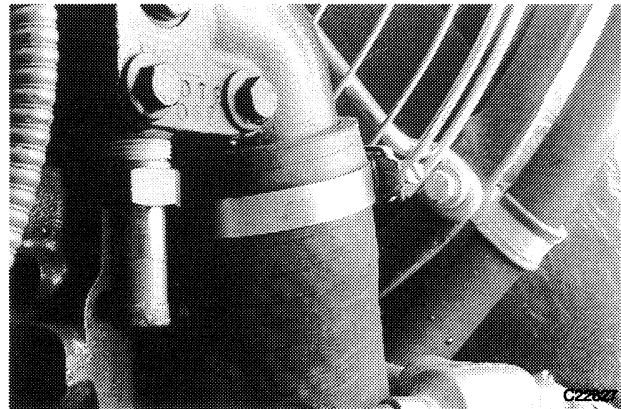

Install the radiator lower hose and tighten the clamps.

STEP 68

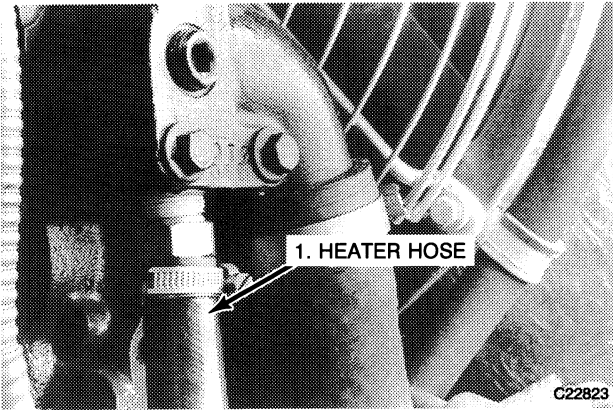

Install the heater hose and tighten the clamp.

STEP 69

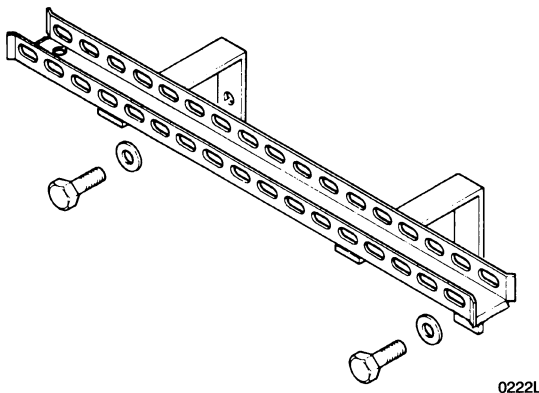

Install the wiring harness carrier and install and tighten the mounting bolts and spacers.

STEP 70

Fill the radiator with specified engine coolant. Install and tighten the radiator cap. Fill the coolant recovery reservoir with specified engine coolant up to the upper mark. Install and tighten the cap. Fill the engine with specified engine oil up to the FULL mark on the engine oil dipstick.

STEP 71

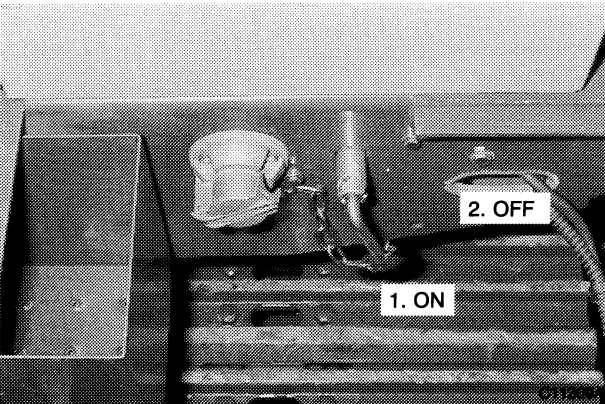

Install the key and turn the master disconnect switch to the ON position.

Don 8-89000

STEP 72

Remove air from the fuel system. Refer to Section 3410.



WARNING: *Never operate the engine in a closed building. Proper ventilation is required under all circumstances.*

STEP 73

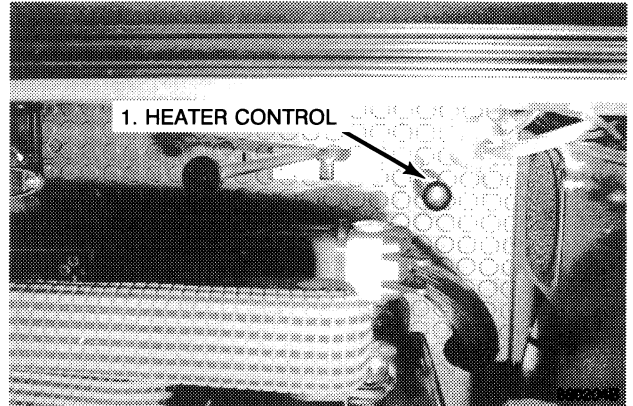

Push down the heater control in the cab to allow circulation of engine coolant and to allow trapped air to collect at the air bleed screw. Start and run the engine for five minutes. Stop the engine.



WARNING: *Hot engine coolant will spray out of air bleed screw. To avoid injury, care must be taken when removing air from the cooling system.*

STEP 74

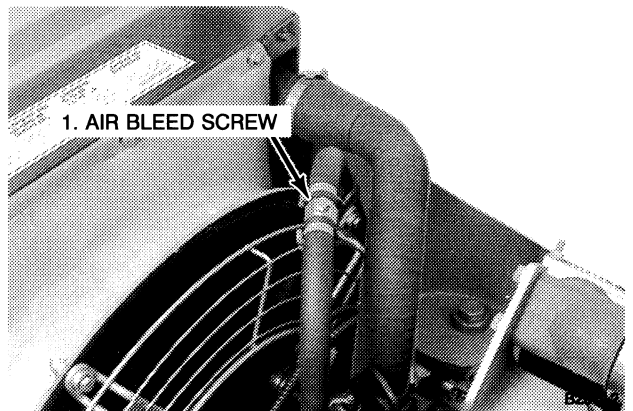

Open the air bleed screw. When there is a flow of engine coolant without air bubbles, tighten the air bleed screw.



Suggest:

If the above button click is invalid.

Please download this document first, and then click the above link to download the complete manual.

Thank you so much for reading

STEP 75

Check for and repair any fuel, engine coolant and engine oil leaks. Check the level of engine oil on the dipstick and the level of engine coolant in the engine coolant recovery reservoir. Top up the levels if necessary.

STEP 76

Install the engine upper access cover. Install and tighten the retaining bolts, spacers and nuts. Install and tighten the safety cable retaining bolt, spacer and nut. Install the engine front cover.

STEP 77

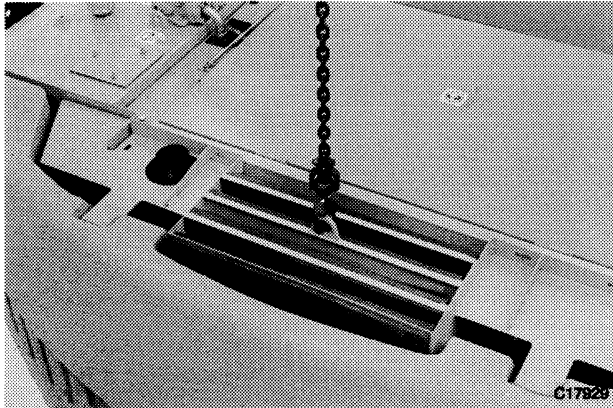

Install the engine insulator. Install and tighten the mounting bolts and spacers.

STEP 78

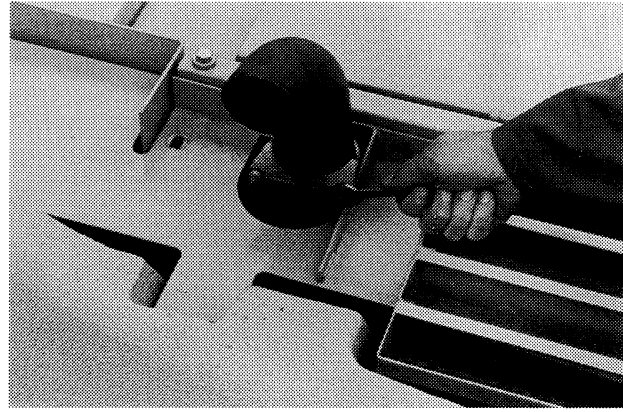

Install the exhaust muffler extension tube. Tighten the nuts on the clamp.

STEP 79

Install the access panels under the engine and under the hydraulic oil tank.

<https://www.ebooklibonline.com>

Hello dear friend!

Thank you very much for reading.

Enter the link into your browser.

The full manual is available for immediate download.

<https://www.ebooklibonline.com>