

680L Loader Backhoe
Service Manual

Table of Contents

Description	Section No.	Form No.
General		
Tab 1		
Section Index - General		8-74751
Torque Specifications	1001	8-71600
Fluids and Lubricants	1002	8-72841
Loctite Product Chart		8-98900
Engines		
Tab 2		
Section Index - Engines		8-74761
Engine Removal and Installation	2001	8-74651
Engine Stall Tests	2002	8-74660
Detailed Engine Specifications	2401	8-26063
Cylinder Head and Valve Train	2415	8-26073
Cylinder Block	2425	8-26084
Lubrication System	2445	8-26093
Cooling System	2455	8-26103
Turbocharger	2465	8-26110
Turbocharger Failure Analysis	2565	9-78235
Fuel System		
Tab 3		
Section Index - Fuel System		8-74771
Fuel System and Filters	3410	8-26131
Fuel Injection Pump - Cav	3411	8-97711
Fuel Injection Pump - Bosch	3412	8-26143
Fuel Injectors	3413	8-26152
Electrical System		
Tab 4		
Section Index - Electrical		8-74781
Specifications, Schematics, Troubleshooting and Booster Batteries	4001	8-72892
Starter and Starter Solenoid	4002	8-72900
Batteries	4004	8-71701
Instrument Cluster	4005	8-72921
65 Ampere Alternator A187873	4007	8-15670
65 Ampere Alternator A186125	4019	8-12902
Steering		
Tab 5		
Section Index - Steering		8-74791
Removal and Installation of Steering Components	5000	8-10370
Specifications, Troubleshooting and Pressure Checks	5001	8-72940
Steering Pump	5002	8-72950
Steering Control Valve	5003	8-72960
Steering Cylinder Repair	5004	8-72970
Flow Control Valve	5005	8-72980
Front Axle - Two Wheel Drive	5006	8-72990
Front Axle - Four Wheel Drive	5007	8-73001

Reprinted

680L Loader Backhoe
Service Manual

Table of Contents

Description	Section No.	Form No.
Power Train		
Tab 6		
Section Index - Power Train		8-74801
Transmission Specification and Troubleshooting	6001	8-73020
Transmission Repair	6002	8-73031
Differential and Planetary Repair	6003	8-73041
Wheels and Tires	6004	8-74680
Clutch Cutout Valve	6005	8-73100
Brakes		
Tab 7		
Section Index - Brakes		8-74811
Removal and Installation of Brake Components	7000	8-10380
Specifications and Troubleshooting	7001	8-73070
Brake Master Cylinder	7002	8-73080
Brake Valve	7003	8-73090
Brakes	7005	8-73111
Parking Brake and Acuator	7006	8-73120
Selector Valve	7007	8-74630
Hydraulics		
Tab 8		
Section Index - Hydraulics		8-74821
Removal and Installation of Hydraulic Components	8000	8-10391
Specifications, Schematics, Troubleshooting and Pressure Checks	8001	8-74691
Cleaning the Hydraulic System	8002	8-73150
Pump Repair	8003	8-73160
Loader Control Valve Repair	8004	8-73170
Backhoe Relief Valve Repair	8005	8-73180
Backhoe Control Valve	8006	8-74701
Stablizer Control Valve	8007	8-73200
Boom Lock	8008	8-73211
Cylinders	8009	8-74712
Mounted Equipment		
Tab 9		
Section Index - Mounted Equipment		8-74831
Pedals and Levers	9000	8-74721
Air Conditioning Troubleshooting and Pressure Checks	9001	8-18910
Discharging and Charging the Air Conditioning System	9002	8-18920
Compressor and Clutch	9003	8-18930
Loader	9004	8-74731
ROPS Cab and ROPS Canopy	9005	8-73280
Standard Seat	9006	8-73290
Suspension Seat and Seat Belt	9007	8-73300
Backhoe	9008	8-74741

1001

STANDARD TORQUE SPECIFICATIONS

TABLE OF CONTENTS

Torque Specifications - Decimal Hardware	1001-2	Torque Specifications - Steel Hydraulic Fittings	1001-4
Torque Specifications - Metric Hardware ...	1001-3	Torque Specifications - O-ring Face Seal Fittings	1001-5

<https://www.ebooklibonline.com>

Hello dear friend!

Thank you very much for reading.

Enter the link into your browser.

The full manual is available for immediate download.

<https://www.ebooklibonline.com>

TORQUE SPECIFICATIONS - DECIMAL HARDWARE

Use the torques in this chart when special torques are not given. These torques apply to fasteners with both UNC and UNF threads as received from suppliers, dry, or when lubricated with engine oil. Not applicable if special graphites, molydisulfide greases, or other extreme pressure lubricants are used.

Grade 5 Bolts, Nuts, and Studs		
		
Size	Pound-Feet	Newton metres
1/4 in	9-11	12-15
5/16 in	17-21	23-28
3/8 in	35-42	48-57
7/16 in	54-64	73-87
1/2 in	80-96	109-130
9/16 in	110-132	149-179
5/8 in	150-180	203-244
3/4 in	270-324	366-439
7/8 in	400-480	542-651
1.0 in	580-696	787-944
1-1/8 in	800-880	1085-1193
1-1/4 in	1120-1240	1519-1681
1-3/8 in	1460-1680	1980-2278
1-1/2 in	1940-2200	2631-2983

Grade 8 Bolts, Nuts, and Studs		
		
Size	Pound-Feet	Newton metres
1/4 in	12-15	16-20
5/16 in	24-29	33-39
3/8 in	45-54	61-73
7/16 in	70-84	95-114
1/2 in	110-132	149-179
9/16 in	160-192	217-260
5/8 in	220-264	298-358
3/4 in	380-456	515-618
7/8 in	600-720	814-976
1.0 in	900-1080	1220-1465
1-1/8 in	1280-1440	1736-1953
1-1/4 in	1820-2000	2468-2712
1-3/8 in	2380-2720	3227-3688
1-1/2 in	3160-3560	4285-4827

NOTE: Use thick nuts with Grade 8 bolts.

TORQUE SPECIFICATIONS - METRIC HARDWARE

Use the following torques when special torques are not given.

These values apply to fasteners with coarse threads as received from supplier, plated or unplated, or when lubricated with engine oil. These values do not apply if graphite or molydisulfide grease or oil is used.

Grade 8.8 Bolts, Nuts, and Studs		
		
Size	Pound-Feet	Newton metres
M4	2-3	3-4
M5	5-6	6.5-8
M6	8-9	10.5-12
M8	19-23	26-31
M10	38-45	52-61
M12	66-79	90-107
M14	106-127	144-172
M16	160-200	217-271
M20	320-380	434-515
M24	500-600	675-815
M30	920-1100	1250-1500
M36	1600-1950	2175-2600

Grade 10.9 Bolts, Nuts, and Studs		
		
Size	Pound-Feet	Newton metres
M4	3-4	4-5
M5	7-8	9.5-11
M6	11-13	15-17.5
M8	27-32	37-43
M10	54-64	73-87
M12	93-112	125-15
M14	149-179	200-245
M16	230-280	310-380
M20	450-540	610-730
M24	780-940	1050-1275
M30	1470-1770	2000-2400
M36	2580-3090	3500-4200

Grade 12.9 Bolts, Nuts, and Studs



Usually the torque values specified for grade 10.9 fasteners can be used satisfactorily on grade 12.9 fasteners.

Section

2001

**ENGINE REMOVAL AND INSTALLATION
AND RADIATOR REMOVAL AND INSTALLATION**

ENGINE REMOVAL

STEP 1



Park the machine on a level surface and apply the parking brake.

STEP 2

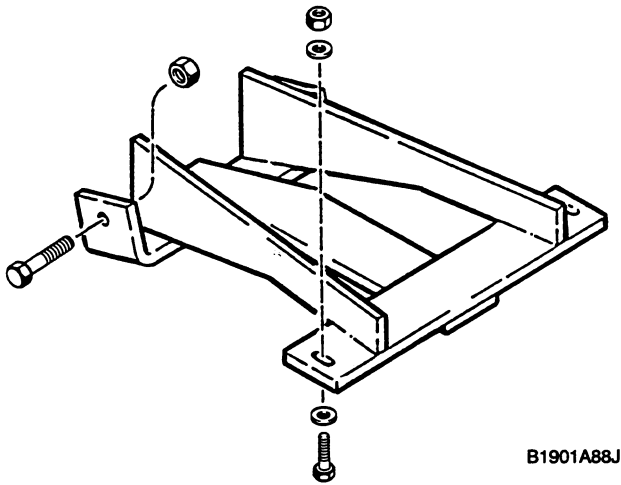

If the machine has four wheel drive, use a floor jack to hold the guard while the nuts, washers, and bolts are being removed.

STEP 3

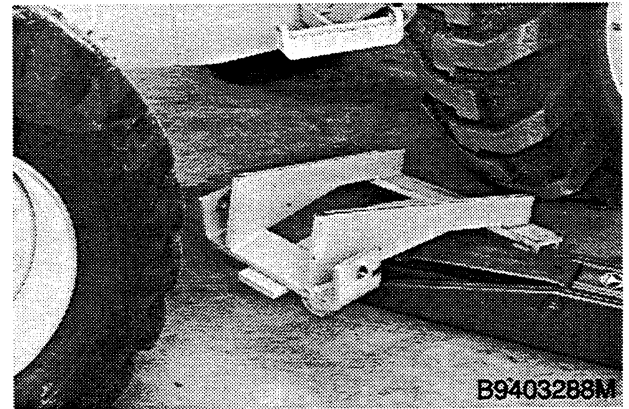

Carefully lower the guard and remove the guard from under the machine.

STEP 4

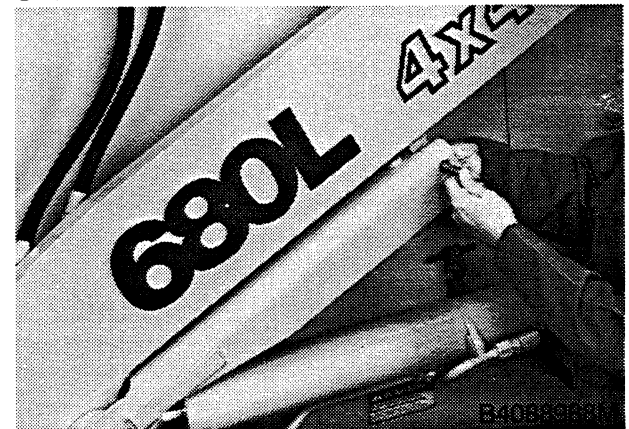

Remove the pin that holds the strut in place and lower the strut onto the lift cylinder.

STEP 5



Raise the loader frame until the strut is against the end of the lift cylinder. Install the pin in the strut. Stop the engine.

STEP 6



Remove both side panels for the engine compartment.

STEP 9

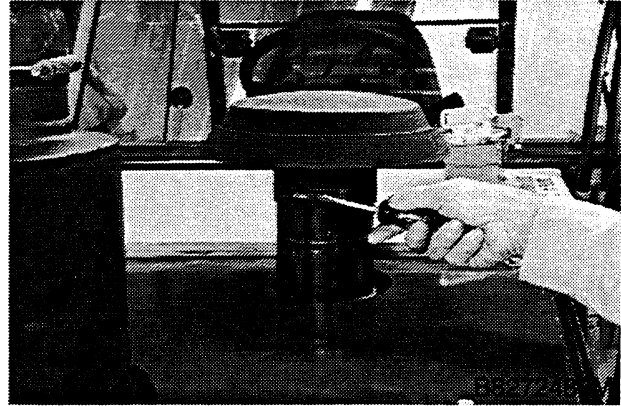

Loosen the clamp for the air cleaner cap and remove the air cleaner cap.

STEP 7

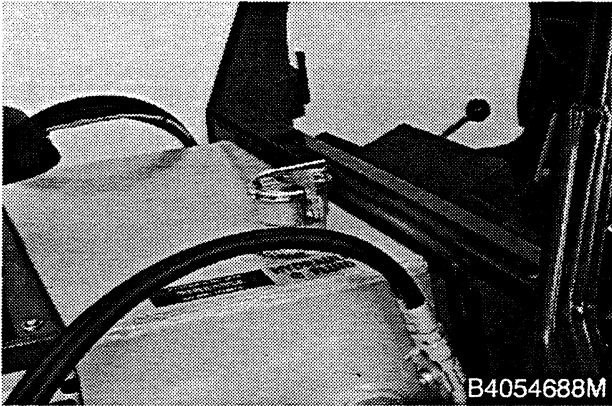

Loosen the fill cap for the reservoir to remove the air pressure.

STEP 10

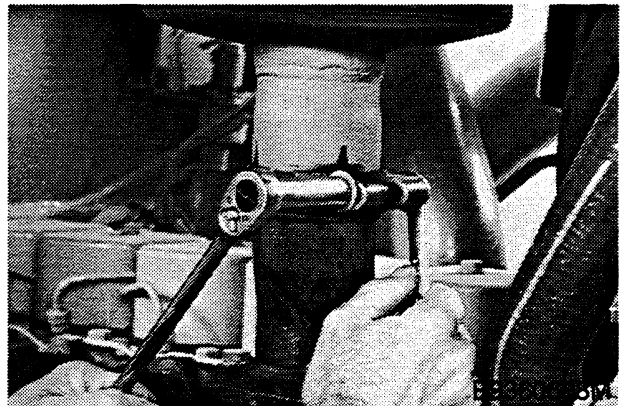

Loosen the clamp for the muffler.

STEP 8

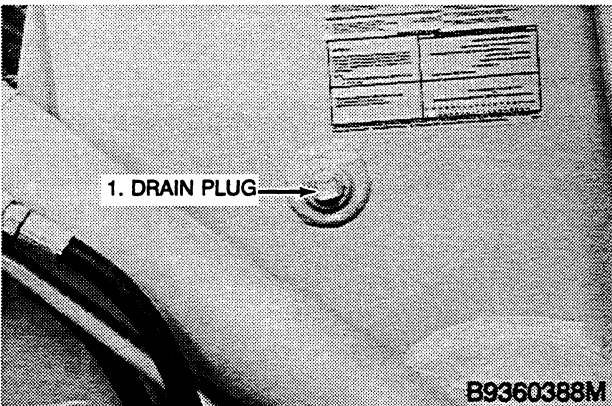

Drain or use a pump to remove the oil from the reservoir. The reservoir contains 18.9 U.S. gallons (71.5 litres) of oil.

STEP 11



Remove the muffler.

STEP 12

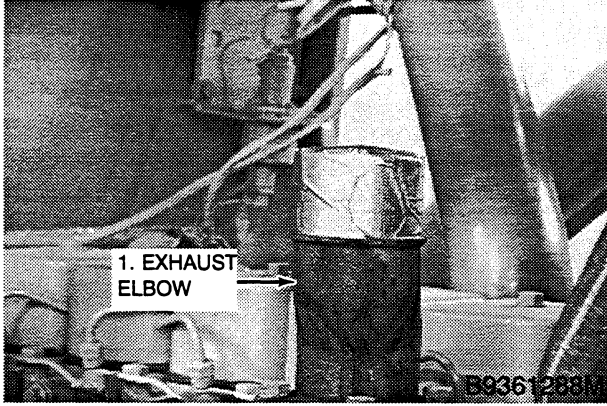

Cover or close the opening in the exhaust elbow.

STEP 13

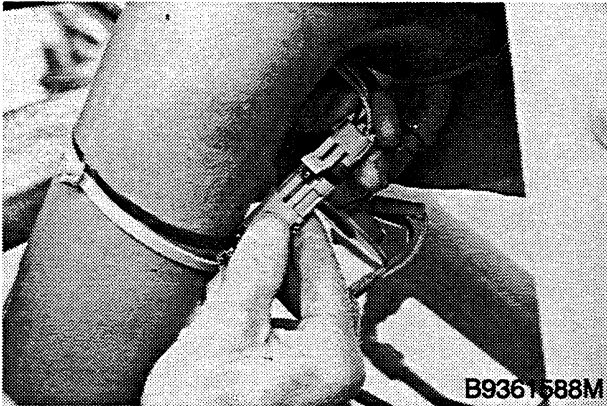

Disconnect the wire harness for the hydraulic oil filter.

STEP 14

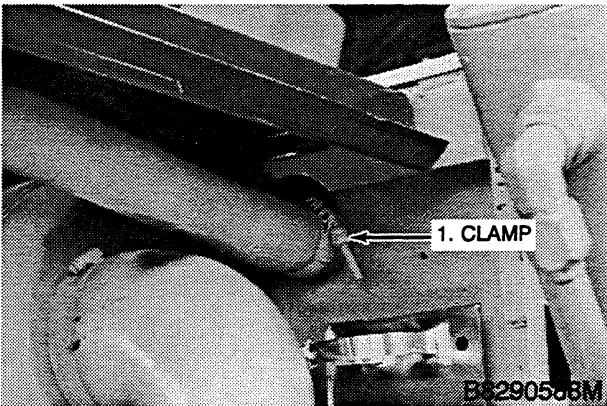

Loosen the clamp that connects the hose from the hydraulic oil filter to the reservoir. Disconnect the hose. Install a plug in the hose and a cap on the reservoir.

STEP 15

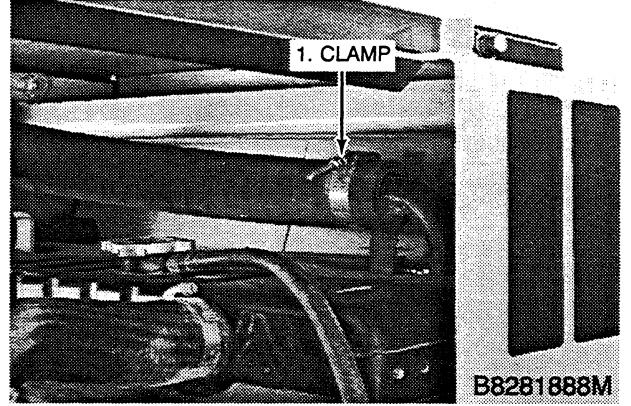

Loosen the clamp that connects the hose for the hydraulic oil filter to the oil cooler. Disconnect the hose. Install a plug in the hose and a cap on the tube.

STEP 16

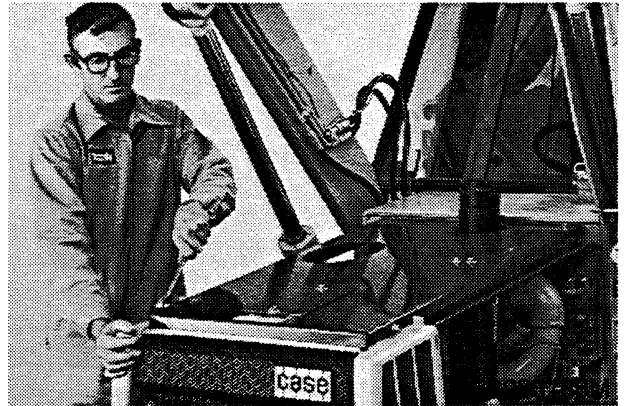

Loosen and remove the cap screws, lock washers, flat washers, and spacers that fasten the front of the hood. Loosen and remove the nuts, lock washers, flat washers, and bolts that fasten the rear of the hood.

STEP 17

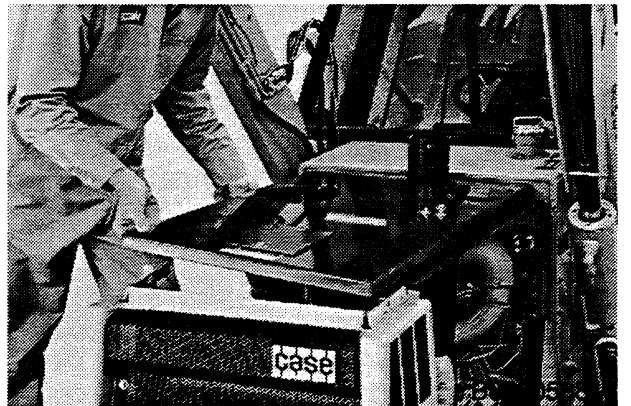

Remove the hood. If necessary, have another person help you.

STEP 18

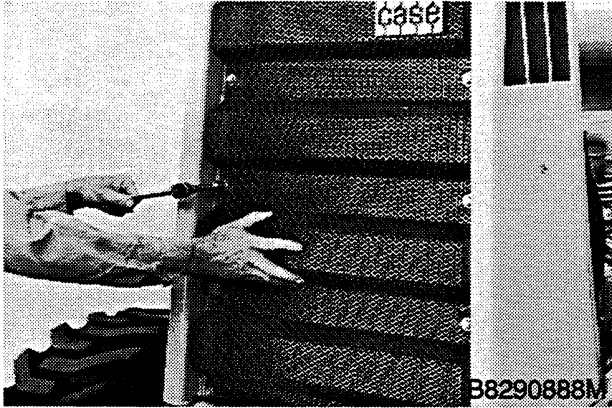

Loosen and remove the cap screws, lock washers, and flat washers that fasten the grille. Remove the grille.

STEP 21

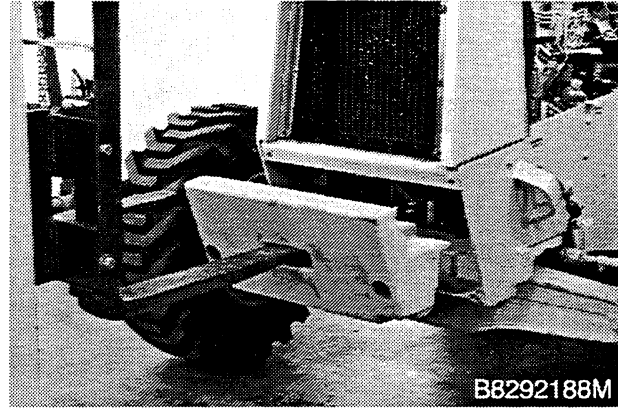

Remove the counterweight.

STEP 19

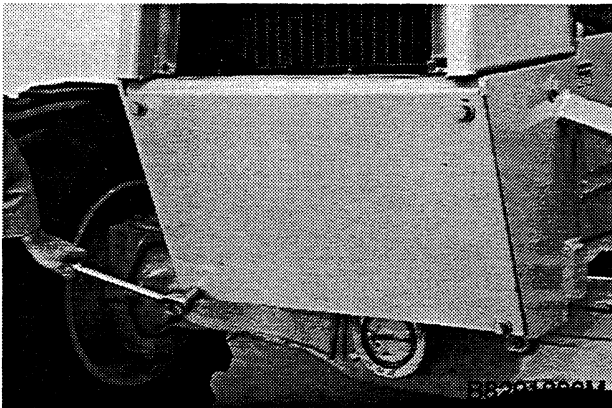

Loosen and remove the cap screws, lock washers, and flat washers that fasten the cover to the front of the machine. Remove the cover.

STEP 22

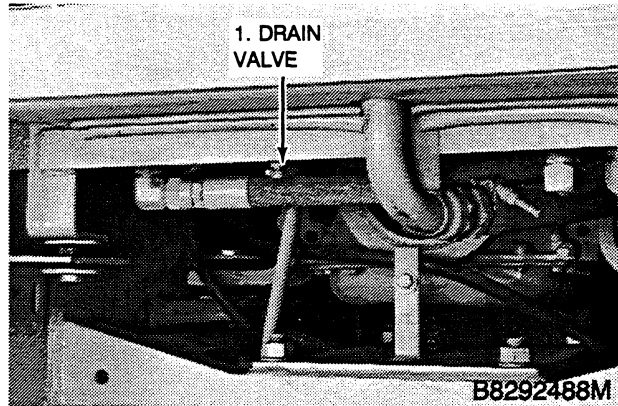

Remove the cap from the radiator and open the drain valve to drain the cooling system. The cooling system holds approximately 6.75 U.S. gallons (25.6 litres) of coolant.

STEP 20

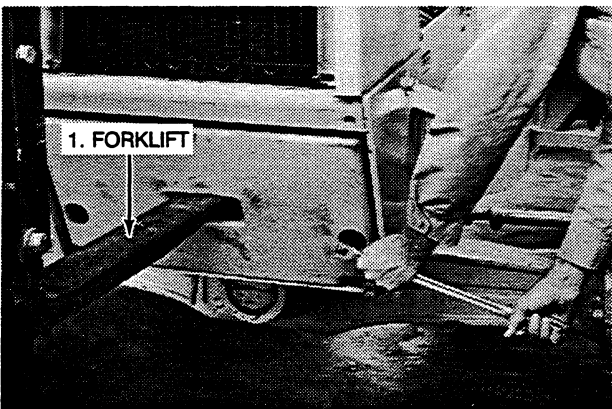

If your machine is equipped with an extendable dipper, loosen and remove the cap screws and flat washers that fasten the counterweight to the frame. The weight of the counterweight is 710 pounds (322 kg).

STEP 23

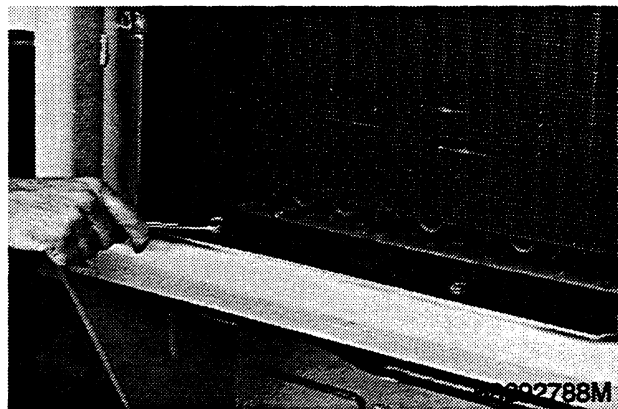

Loosen and remove the cap screws, lock washers, and flat washers that fasten the plate to the frame. Remove the plate.

STEP 24

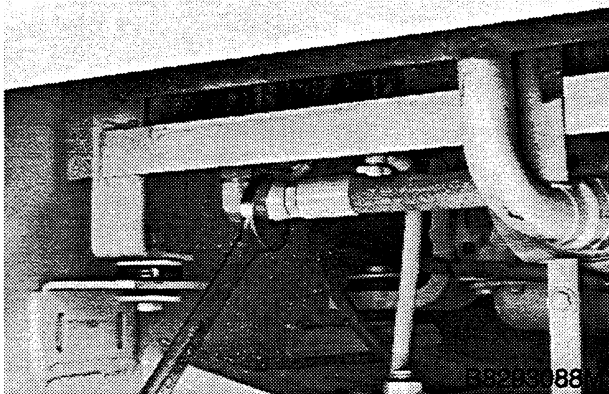

Disconnect the hose from the right side of the transmission oil cooler.

STEP 27

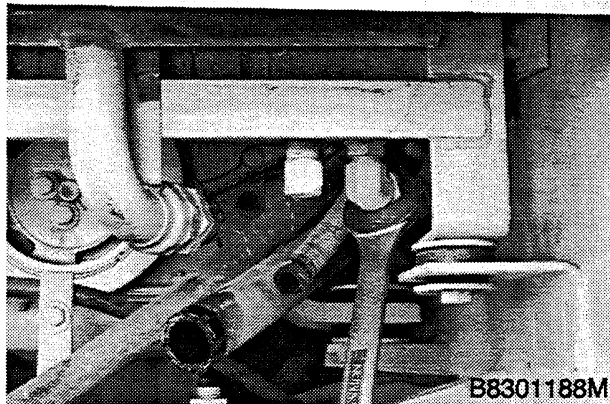

Disconnect the hose from the left side of the transmission oil cooler.

STEP 25

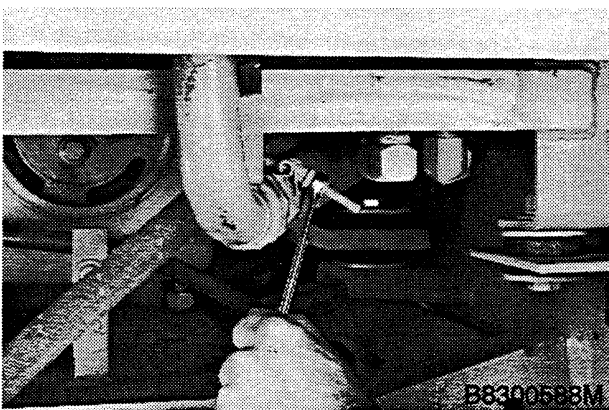

Loosen the clamp and disconnect the hose from the hydraulic oil cooler.

STEP 28

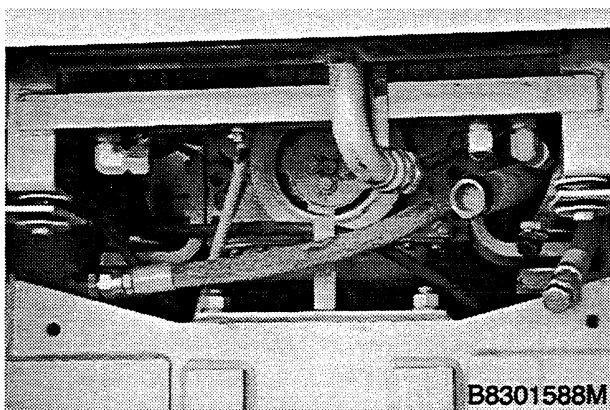

Install plugs in the hoses and caps on the fittings.

STEP 26

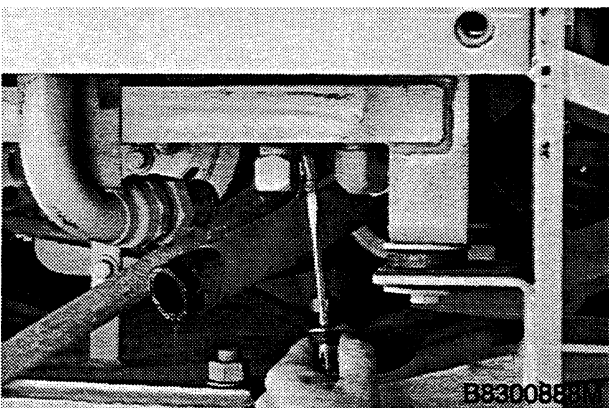

Loosen the clamp and disconnect the hose from the fitting.

STEP 24

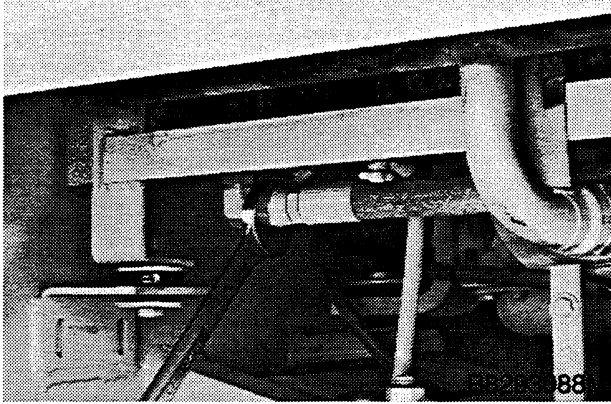

Disconnect the hose from the right side of the transmission oil cooler.

STEP 27

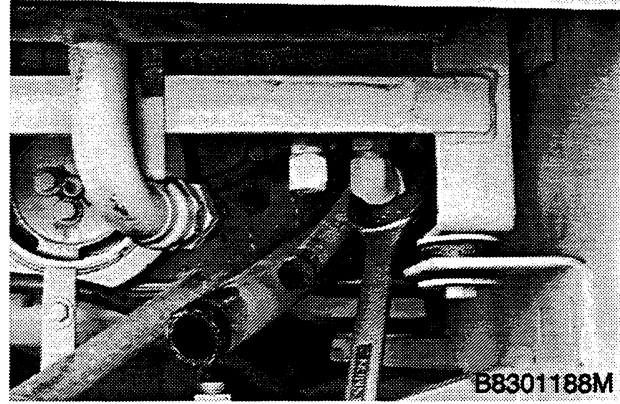

Disconnect the hose from the left side of the transmission oil cooler.

STEP 25

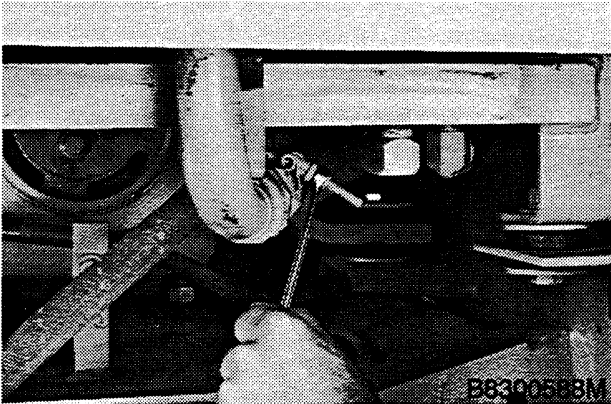

Loosen the clamp and disconnect the hose from the hydraulic oil cooler.

STEP 28

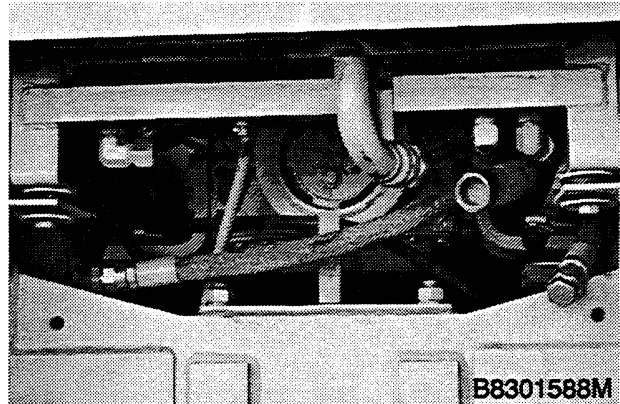

Install plugs in the hoses and caps on the fittings.

STEP 26

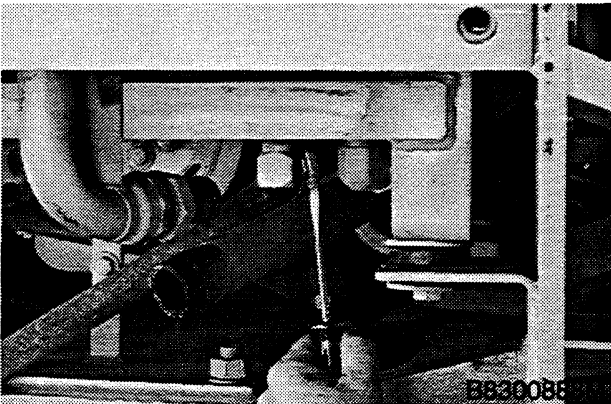

Loosen the clamp and disconnect the hose from the fitting.

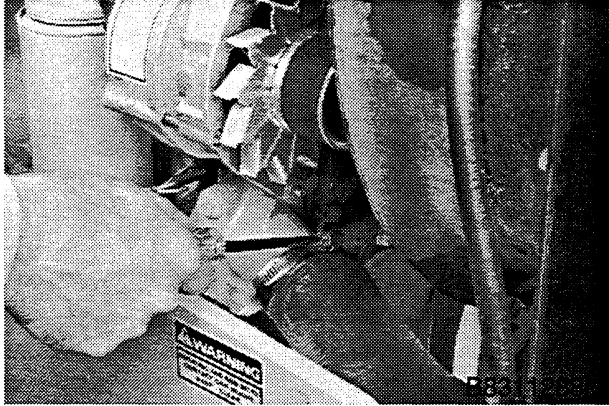
STEP 35

Loosen the clamp and disconnect the bottom radiator hose from the water pump.

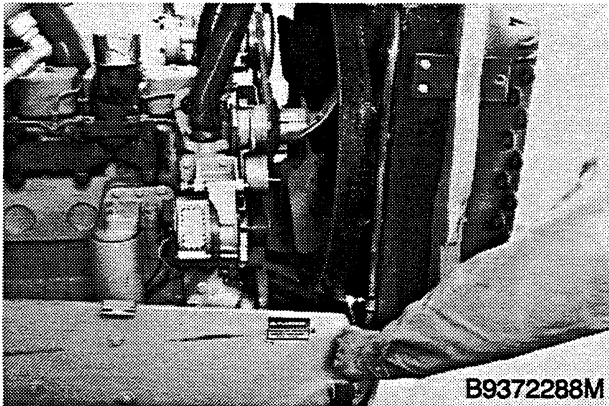
STEP 36

Loosen and remove the cap screws, lock washers, and flat washers that hold the clamps for the hoses and the fan shroud to each side of the radiator. Move the hoses out of the way and move the fan shroud toward the engine.

If the machine is equipped with air conditioning, do the following:

Remove the hardware that fastens the condenser and oil cooler to the radiator.

Move the condenser to the LH side out of the way.

Disconnect the two wire connectors at the compressor.

Remove all clamps and tie straps that fasten the condenser, compressor, and receiver/drier hoses to the engine and other hoses and tubes.

Remove the hardware that fastens the compressor to the mounting bracket, then remove the drive belt and lay the compressor over the side of the frame.

Bur 8-74651

Remove the clamp that fastens the receiver/drier to the LH side of the engine and lay the receiver/drier over the side of the frame.

NOTE: If the air conditioning system must be broken, see Section 9002 for discharging the air conditioning system.

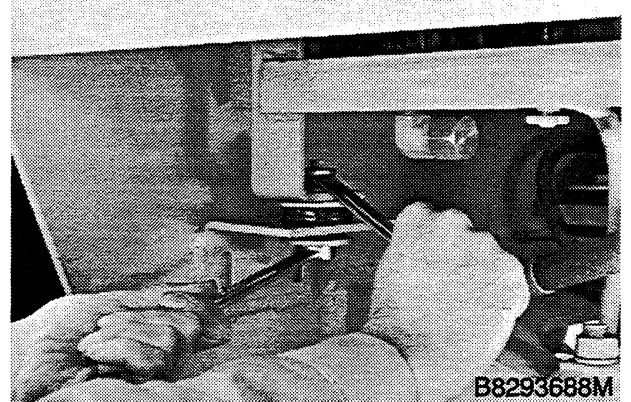
STEP 37

Loosen and remove the nuts, lock washers, flat washers, and bolts that fasten the support for the radiator and oil cooler.

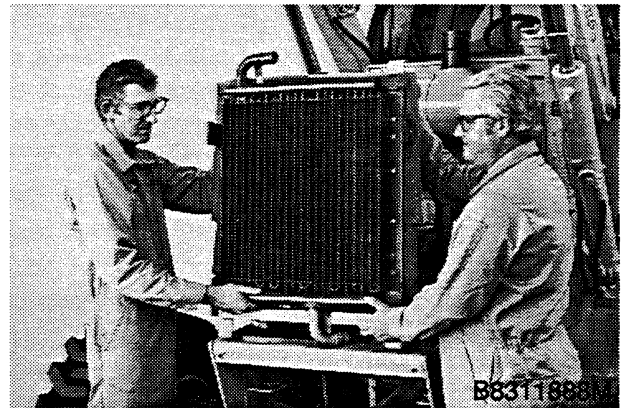
STEP 38

Remove the radiator and oil cooler from the machine.

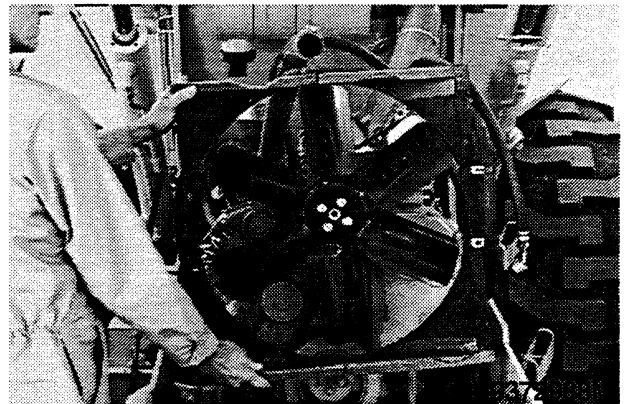
STEP 39

Remove the fan shroud.

STEP 40

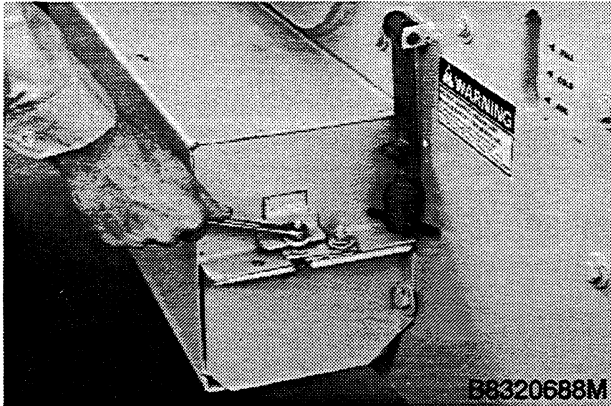

Loosen the nuts that hold the cover for the batteries in place. Remove the cover.

STEP 43

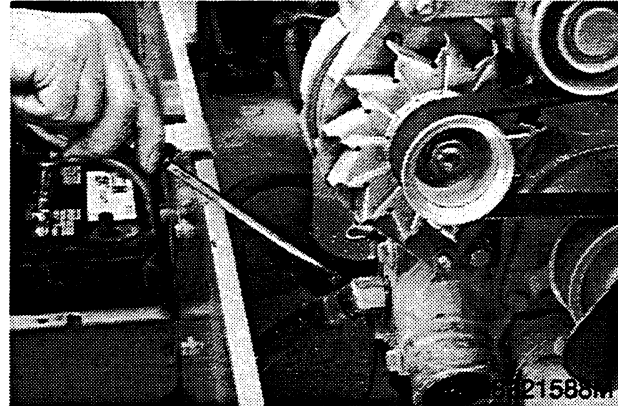

Loosen the clamp on the heater hose and disconnect the hose. Install a plug in the hose.

STEP 41

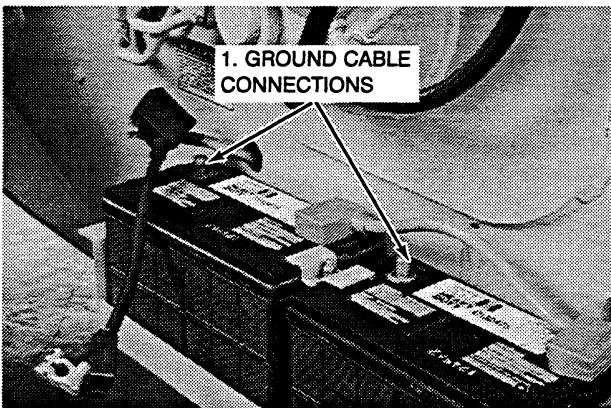

Disconnect the ground cable from both batteries.

STEP 44

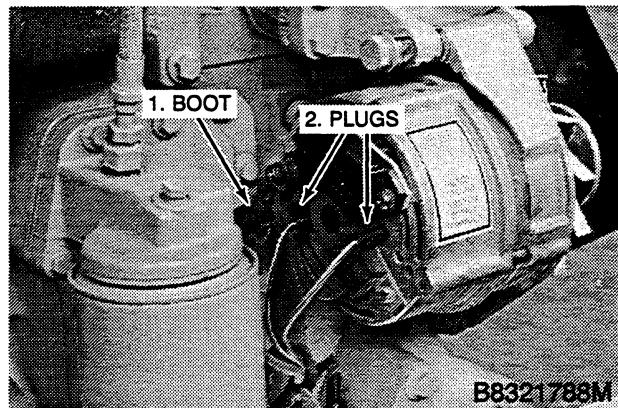

Remove the boot and disconnect the wire and both plugs from the alternator.

STEP 42

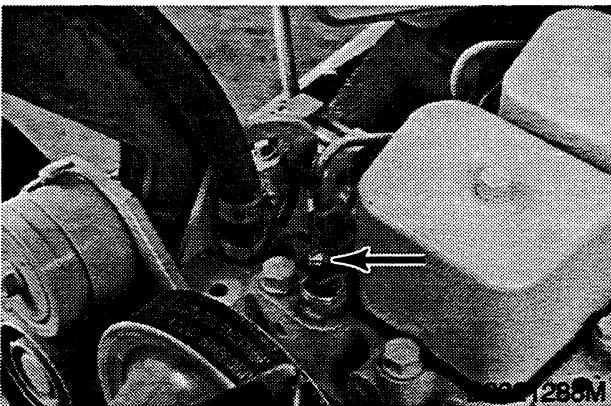

Disconnect wire from the temperature switch. Cut the tie strap that fastens the wire for the temperature switch.

STEP 45

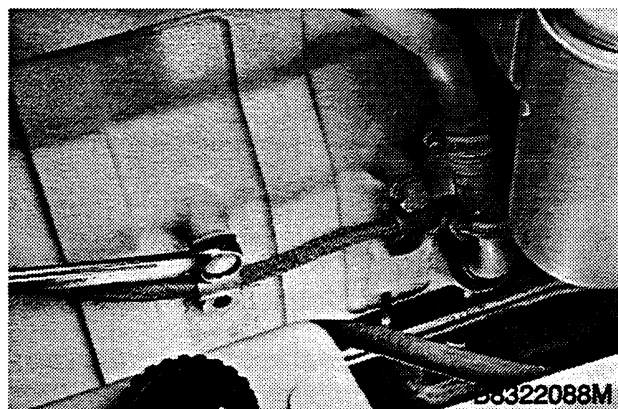

Loosen and remove the cap screws and lock washers that fasten the clamps for the wire harness to the engine.

STEP 46

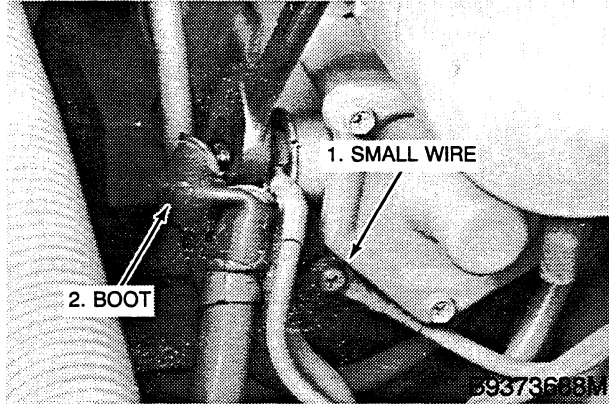

Remove the boot and disconnect the cables from the battery terminal on the starter. Disconnect the small wire from the start terminal on the starter.

STEP 49

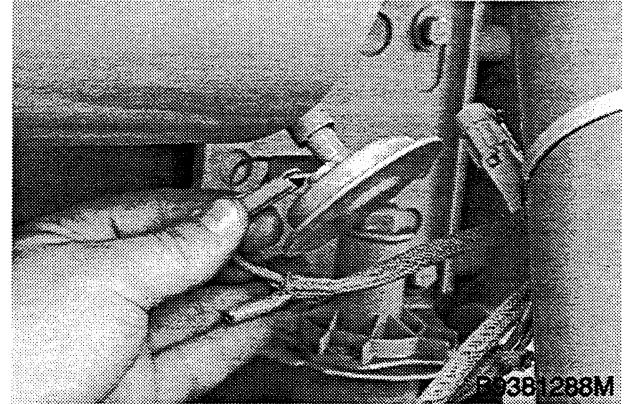

Disconnect the wires from the switch for the air cleaner warning lamp.

STEP 47

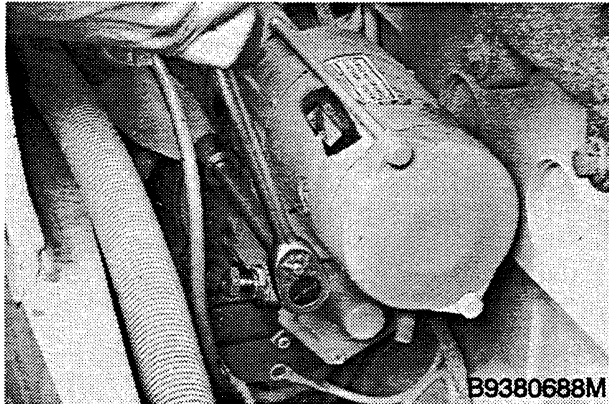

Loosen and remove the cap screw and lock washer that fasten the brace for the dipstick and the ground strap to the starter.

STEP 50

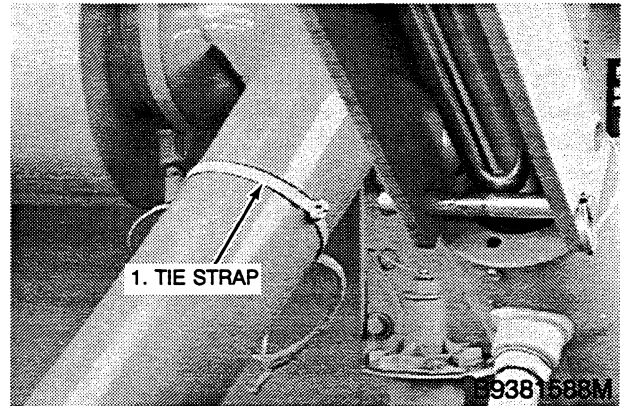

Cut the tie strap that fastens the wires for the switch for the air cleaner warning lamp and the wires for the hydraulic oil filter to the intake hose.

STEP 48

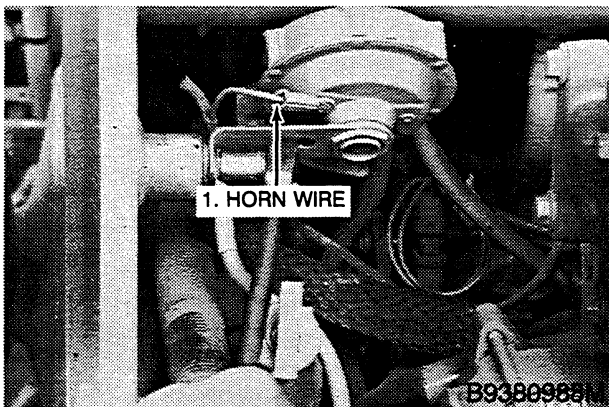

Disconnect the horn wire from the horn. Loosen and remove the nut and lock washer that fasten the cable, horn, and ground strap to the frame. Remove the cable, horn and ground strap.

STEP 51

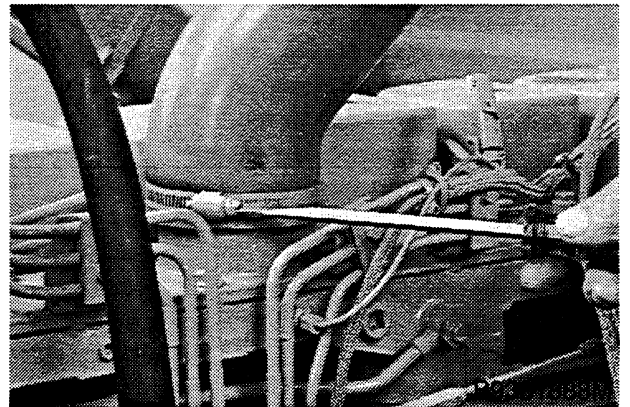

Loosen the clamp on the intake hose for the air cleaner at the turbocharger. Disconnect the hose.

STEP 52

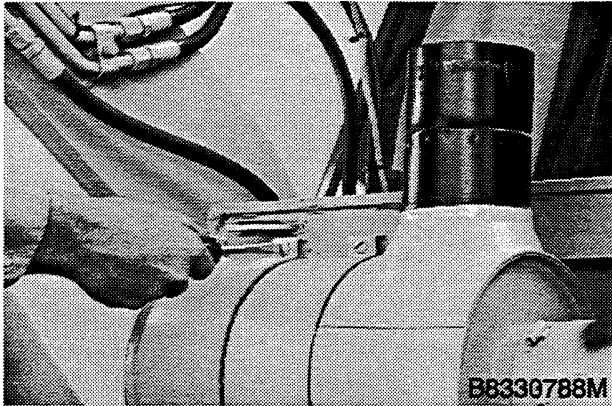

Loosen and remove the nuts and screws that fasten the air cleaner in the mounting straps.

STEP 53

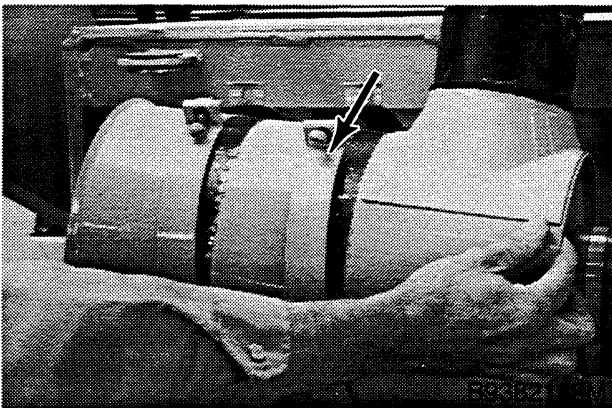

Remove the air cleaner.

STEP 54

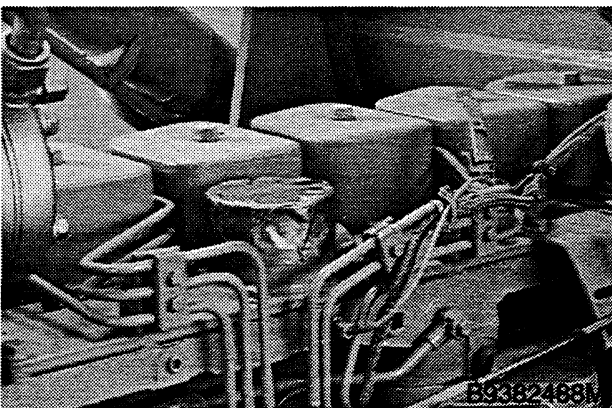

Cover or close the opening in the intake manifold.

STEP 55

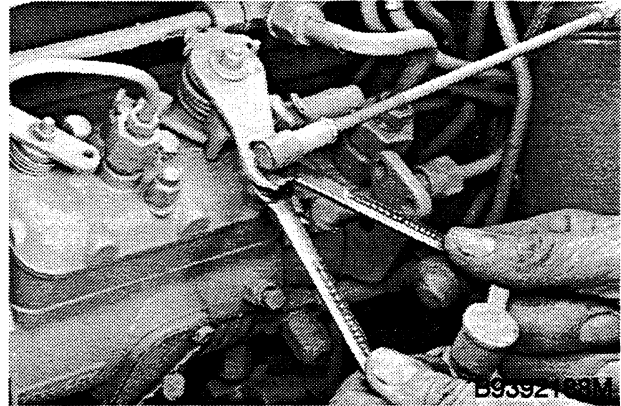

Disconnect the throttle cable from the arm on the fuel injection pump.

STEP 56

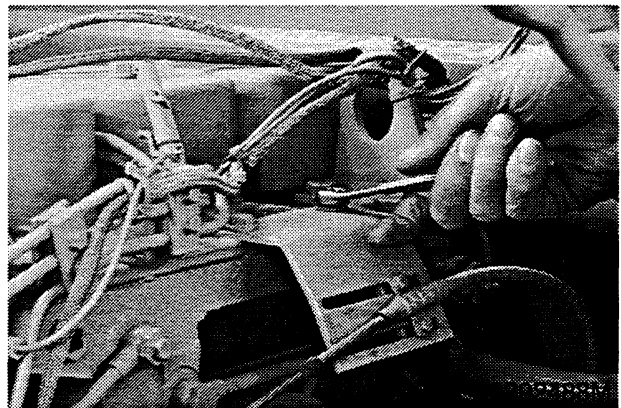

Loosen and remove the cap screws that fasten the bracket for the throttle cable to the engine. Move the throttle cable and bracket out of the way.

STEP 57

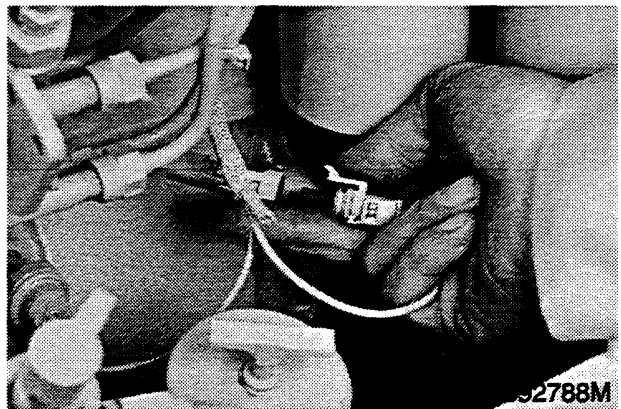

Disconnect the wiring from the connector for the fuel injection solenoid on the fuel injection pump.

STEP 58

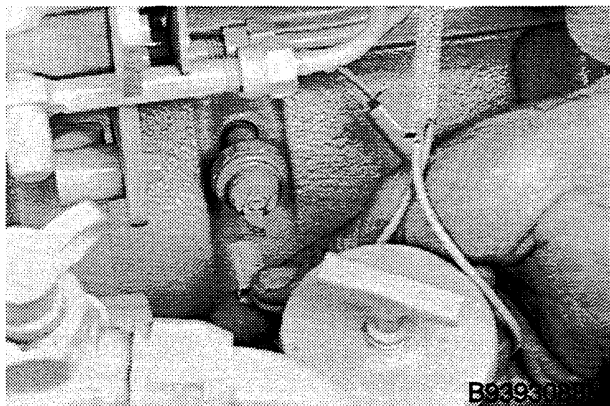

Disconnect the wire harness from the oil pressure switch.

STEP 61

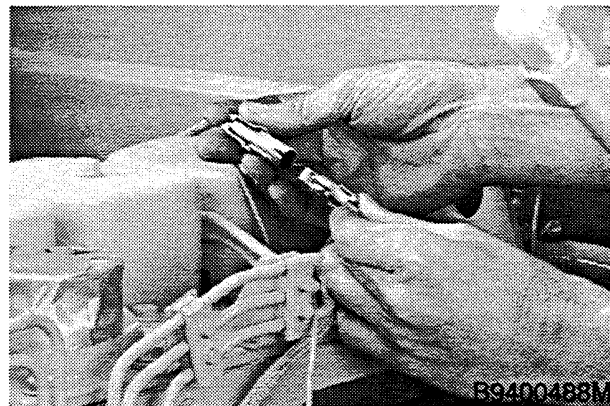

If the machine is equipped with ether injection, disconnect the wiring from the connector for the temperature switch.

STEP 59

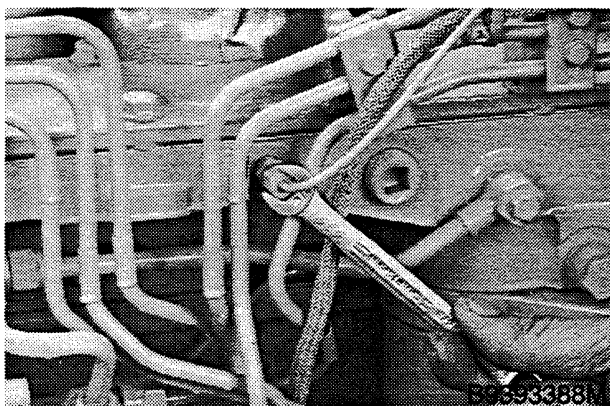

If the machine is equipped with ether injection, disconnect the tube from the intake manifold.

STEP 62

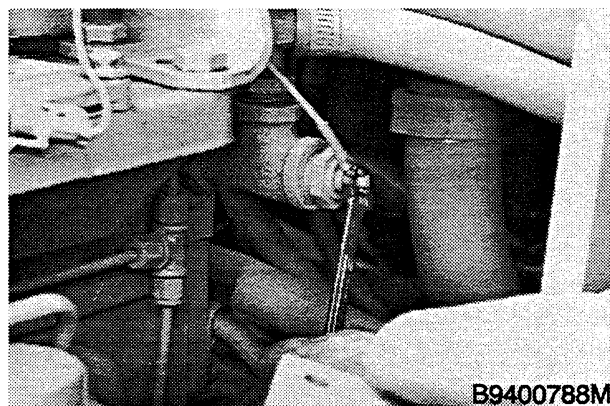

Disconnect the wire for the heater temperature switch. Move all of the wiring and the wire harness out of the way.

STEP 60

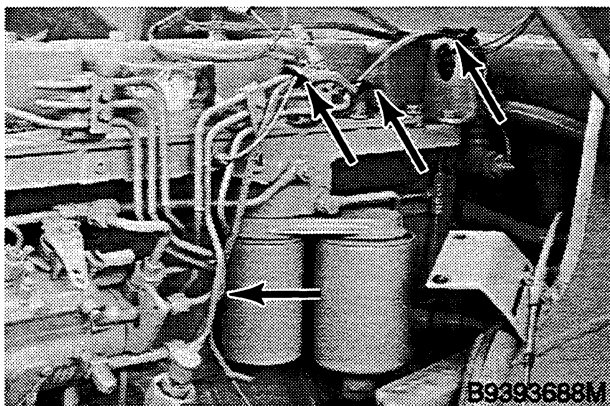

Cut the tie straps that fasten the wire harness and the tube for the ether injection, if equipped.

STEP 63

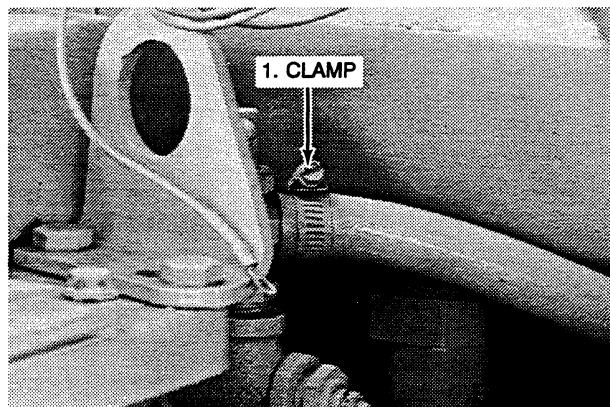

Loosen the clamp on the heater hose and disconnect the hose. Install a plug in the hose and a cap on the fitting.

STEP 64

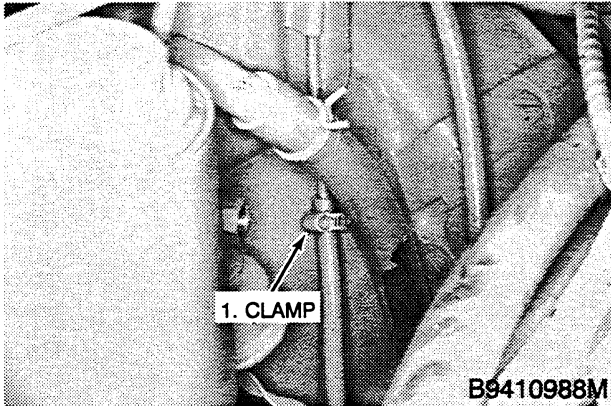

Close the shutoff valve for the fuel line at the bottom of the fuel tank. Loosen the clamp on the hose for the fuel return line and disconnect the hose. Install a plug in the hose and a cap on the fuel return line.

STEP 65

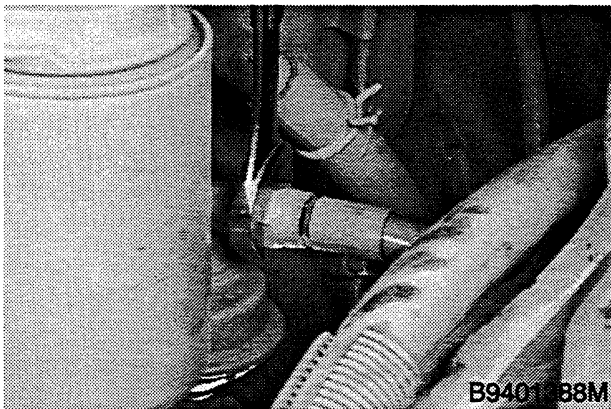

Disconnect the fuel supply line from the hand primer pump. Install a plug in the hose and a cap on the fitting.

STEP 66

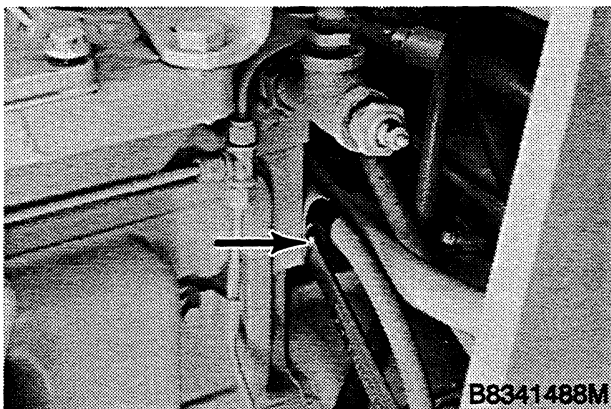

Loosen and remove the cap screw and lock washer that fasten the clamp for the hose to the rear of the engine.

STEP 67

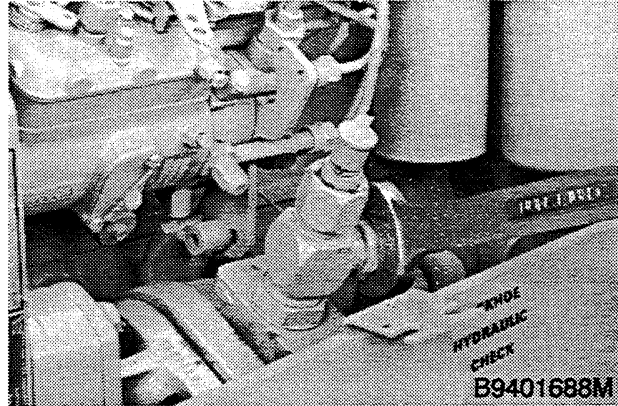

Disconnect the top hose from the hydraulic pump. Install a plug in the hose and a cap on the fitting.

STEP 68

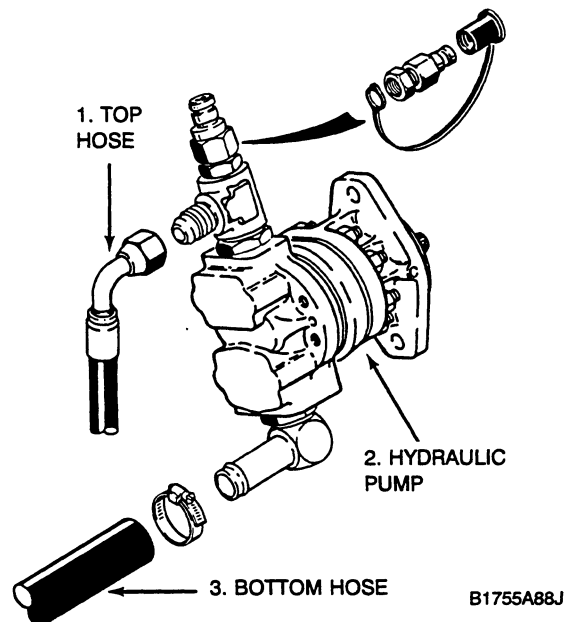

Disconnect the bottom hose from the hydraulic pump. Install a plug in the hose and a cap on the fitting.

NOTE: There are eight cap screws with lock washers that fasten the flex plates to the flywheel. The engine must be rotated to align each cap screw with the access hole in the flywheel housing at the left side of the engine.

STEP 69

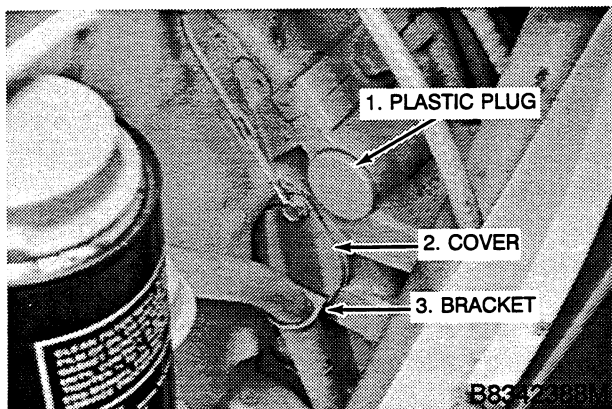

Remove the plastic plug from the flywheel housing. Remove the hose from the bracket and remove the cover and gasket from the access hole for the cap screws.

STEP 70

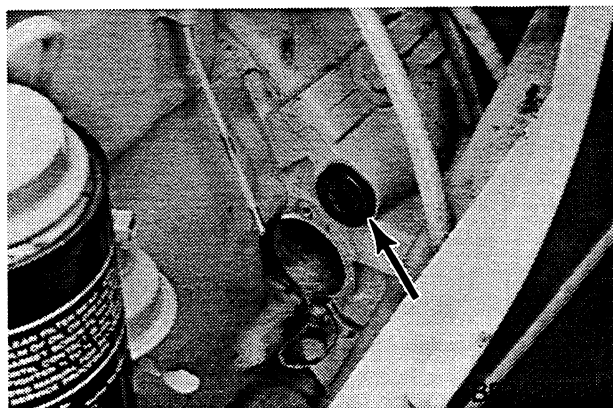
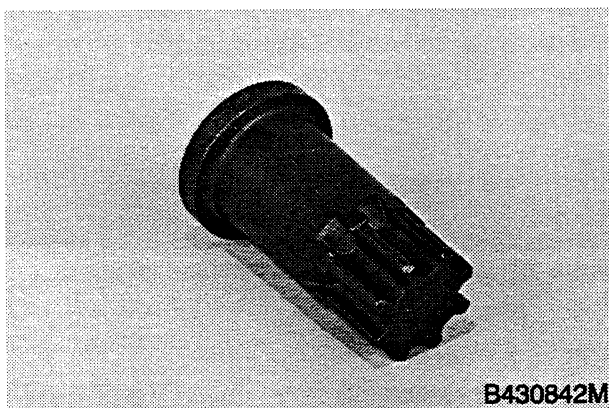

Install the CAS-1690 tool shown above to turn the flywheel.

STEP 71

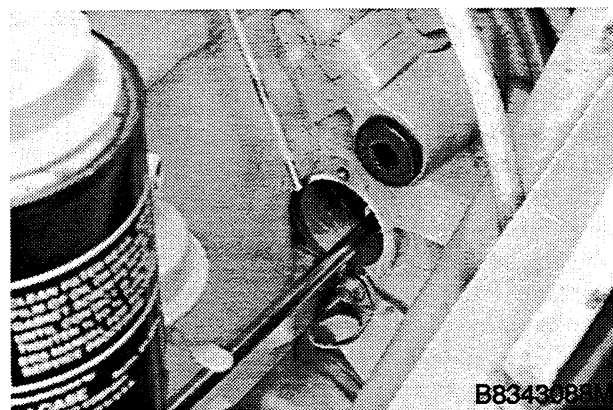

Loosen and remove all eight cap screws and lock washers that fasten the flex plates to the flywheel.

STEP 72

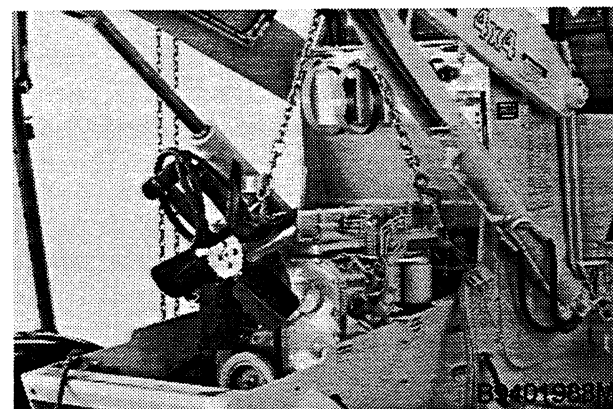

Connect an adjustable lifting sling to the lifting eyes on the engine. Connect a chain hoist to the adjustable lifting sling.

STEP 73

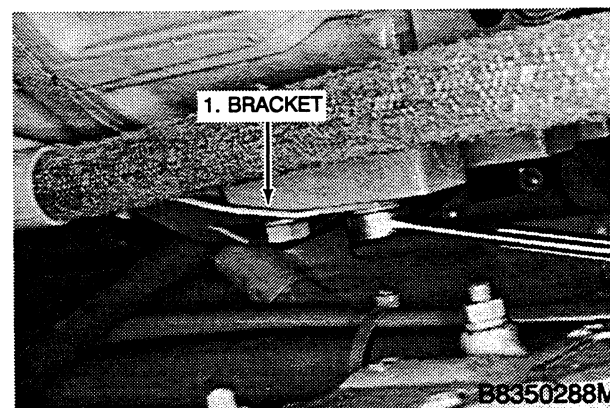

Loosen and remove the cap screws and lock washers that fasten the bracket to the left side of the flywheel housing. Remove the bracket.

STEP 74

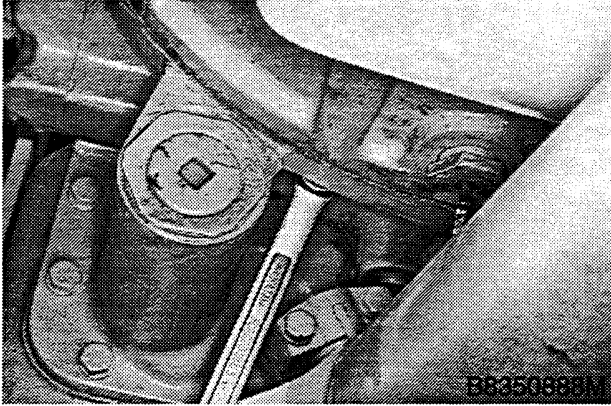

Loosen and remove the cap screws and lock washers that fasten the transmission to the flywheel housing.

STEP 75

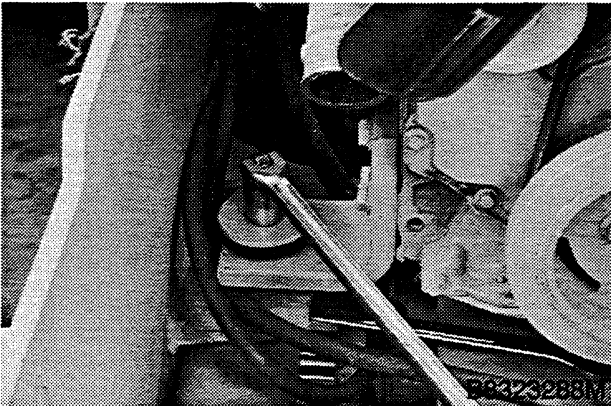

Loosen and remove the self-locking nuts, hardened washers, and bolts that fasten both front engine mounting brackets to the frame.

NOTE: *There is a stud located on each side of the flywheel housing. Loosen and remove the nut and lock washer from the stud on the left side of the flywheel housing.*

STEP 76

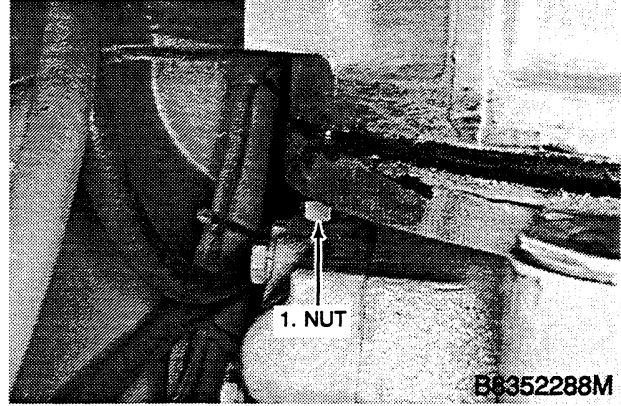

The other stud is located on the right side of the flywheel housing next to the transmission control valve. Loosen the nut on the stud. Move the engine forward and remove the nut and lock washer from the stud.

STEP 77

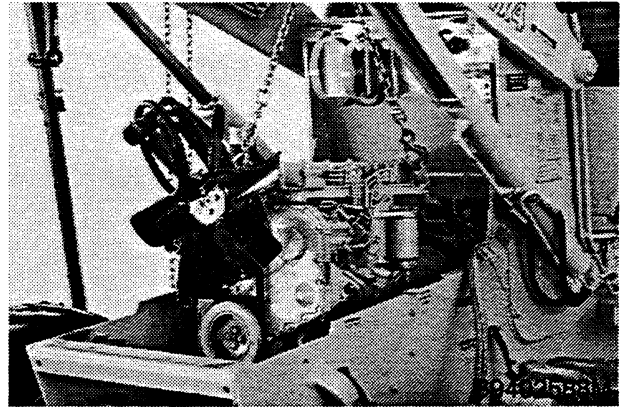

Move the engine forward and raise the engine.

STEP 78

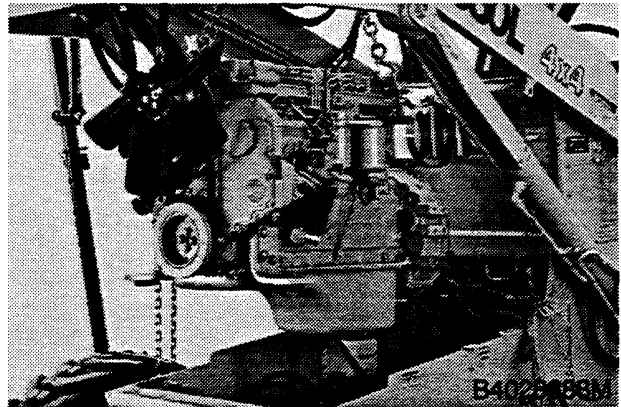

Remove the engine from the machine.

ENGINE INSTALLATION

STEP 79

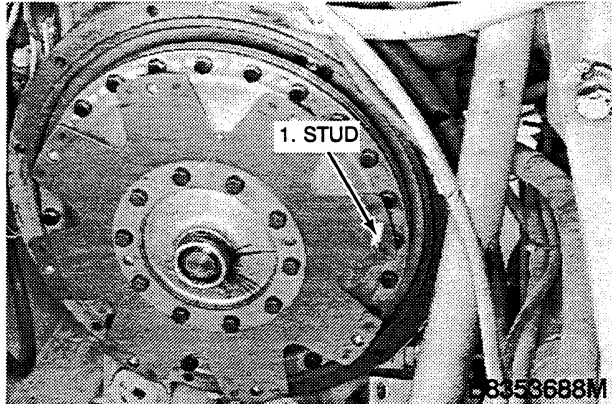

Install a stud 2-3/4 inches (70 mm) long with 3/8 NF threads in one of the holes in the flex plates. Turn the flex plates so that the stud is to the left side as shown. Make sure that the flex plates are not bent or damaged. Turn the crankshaft to align one of the holes in the flywheel with the stud.

STEP 82

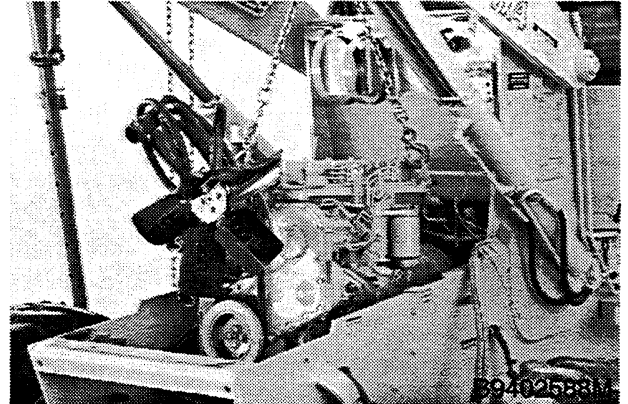

Lower the engine and move the engine toward the rear. Have another person align the stud in the flex plates with the hole in the flywheel.

STEP 80

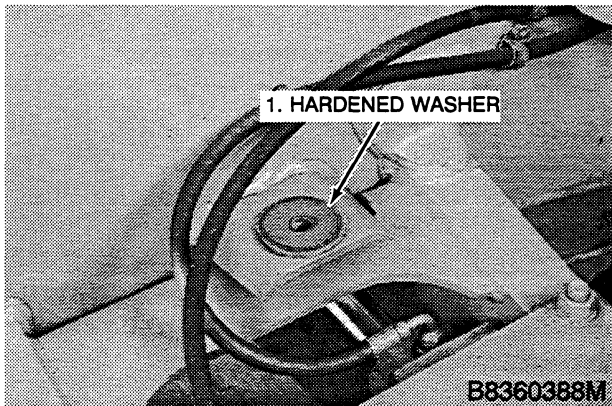

Make sure the hardened washer is installed on each front engine mounting bracket.

STEP 83

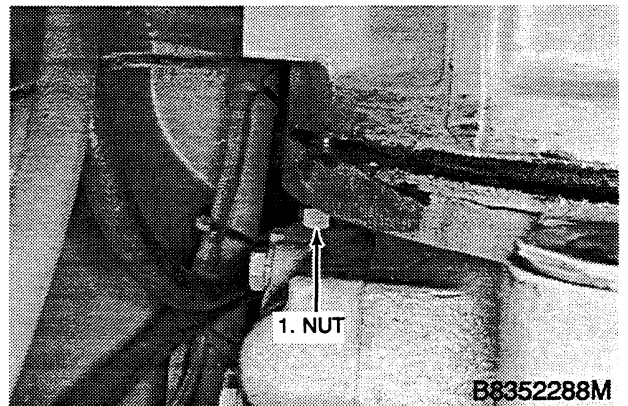

Install the lock washer and nut on the stud located on the right side of the flywheel housing next to the transmission control valve. Install the lock washer and nut on the other stud at the left side of the flywheel housing.

STEP 81

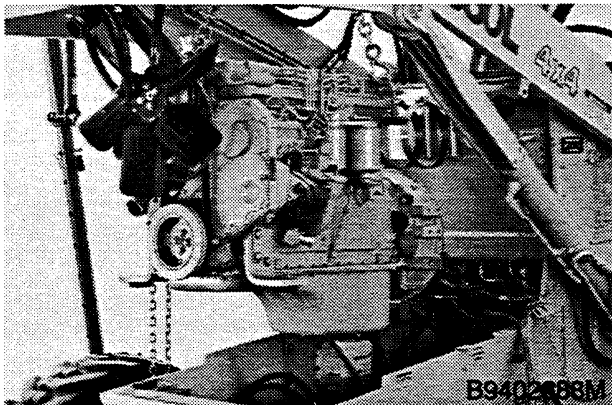

Lower the engine through the loader frame.

Bur 8-74651

STEP 84

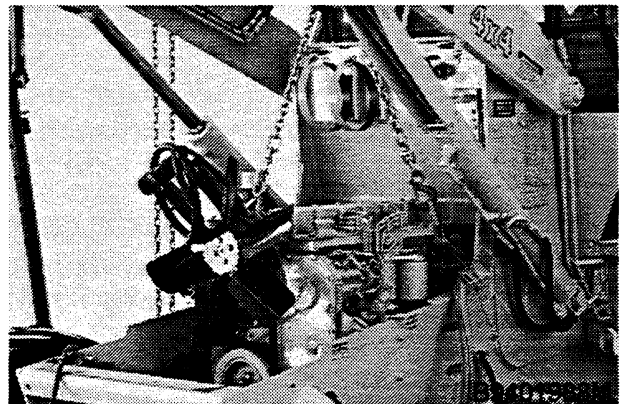

Push the engine to the rear.

STEP 85

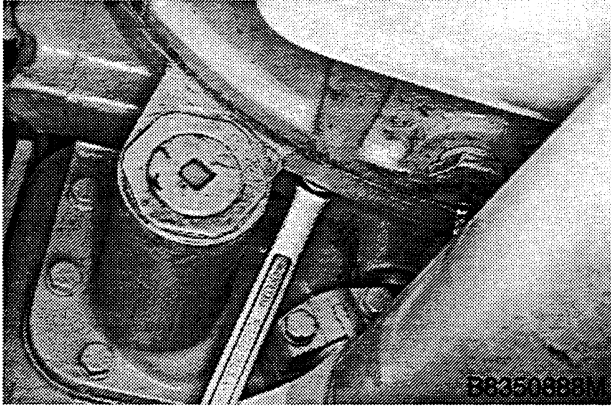

Install and tighten the cap screws and lock washers that fasten the transmission to the flywheel housing. Tighten the nut on the left side of the flywheel housing.

STEP 88

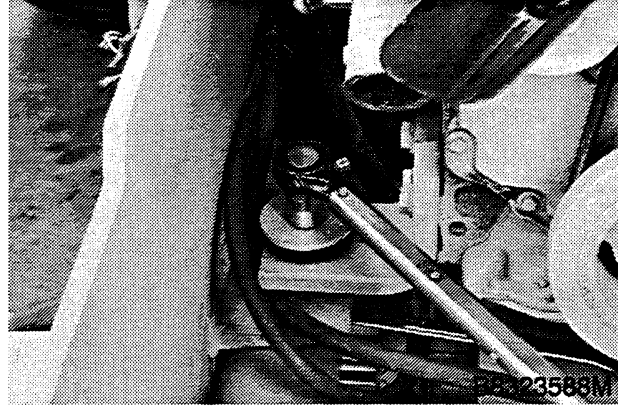

Install the bolts, hardened washers, and self-locking nuts that fasten the front engine mounting brackets to the frame. Tighten the bolts to 150 to 160 pound-feet (203 to 217 Nm).

STEP 86

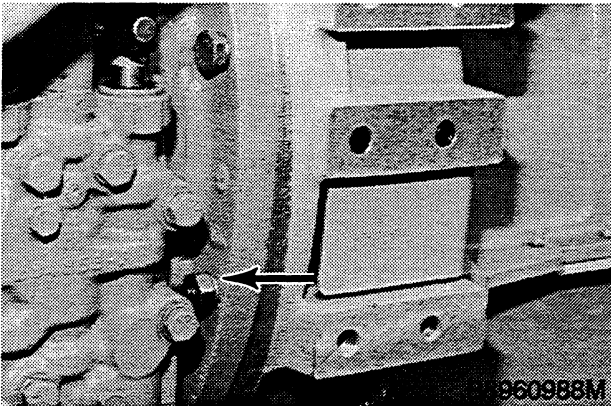

Tighten the nut on the right side of the flywheel housing.

STEP 89

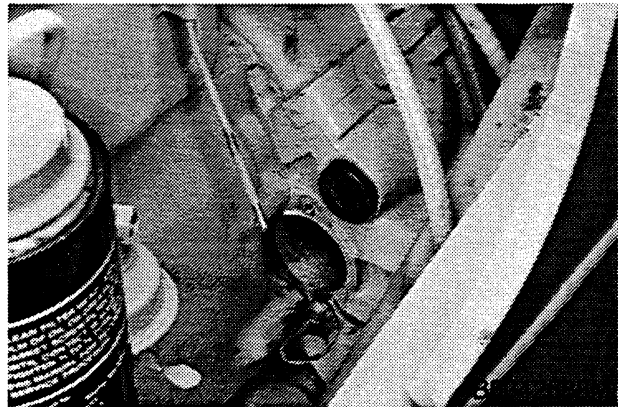

Remove the stud from the flex plates and install a cap screw and lock washer. Install the CAS-1690 tool to turn the flywheel.

STEP 87

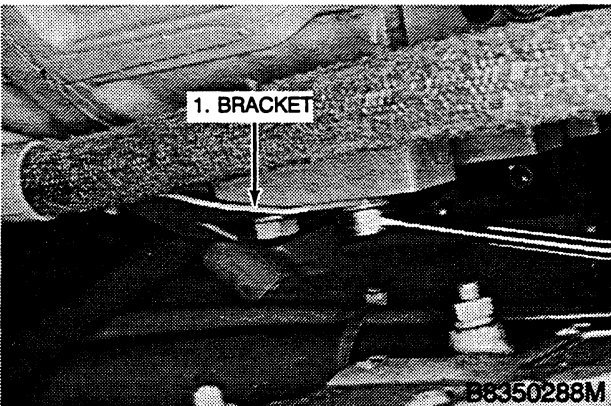

Install the cap screws and lock washers that fasten the bracket to the left side of the flywheel housing. Tighten the cap screws.

STEP 90

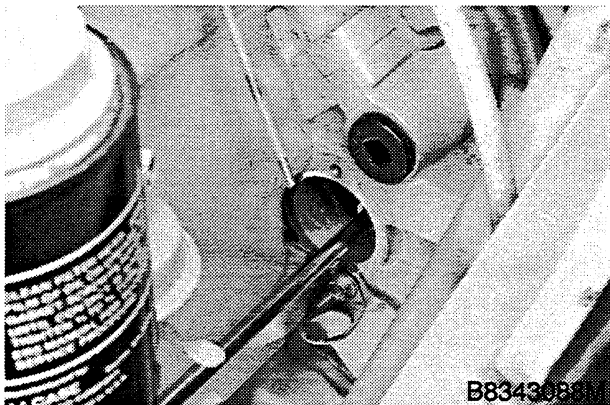

Install the remainder of the cap screws and lock washers. Tighten the cap screws to 300 to 360 pound-inches (34 to 41 Nm).

NOTE: If one or more of the cap screws is difficult to install, there is a plate located on the right side of the flywheel housing. Removal of the plate will give you access to the hole in the flywheel for the cap screw and also the flex plates behind the flywheel.

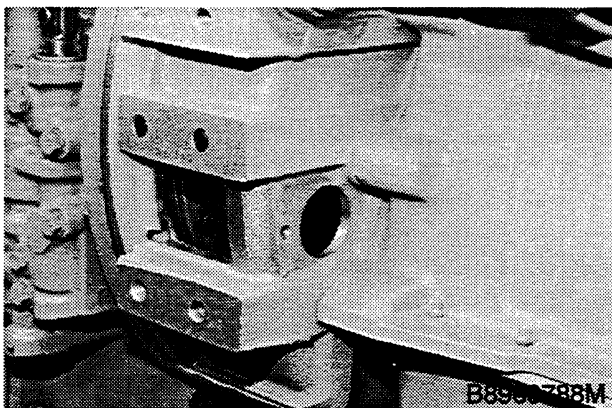
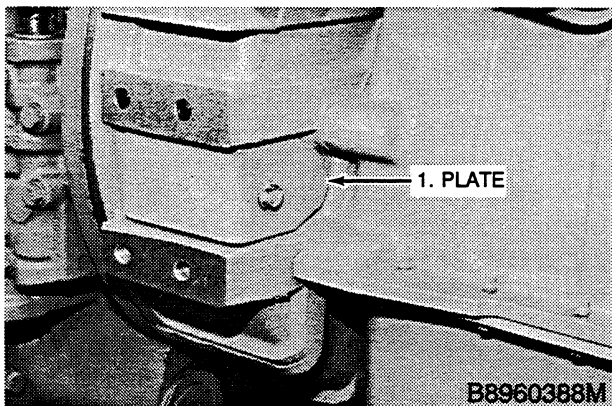

STEP 91

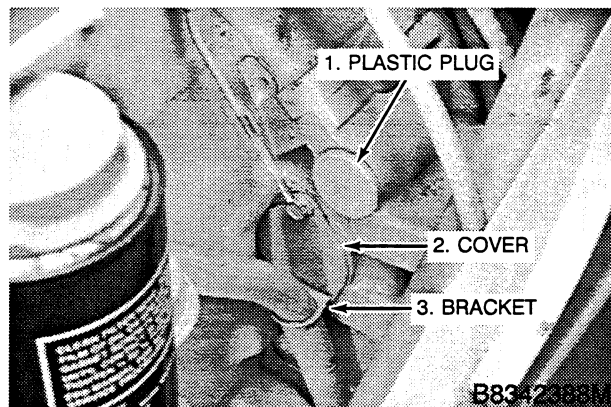

Remove the CAS-1690 tool and install the plastic plug. If necessary, install a new gasket on the cover for the access hole in the flywheel housing. Install the cover. Install the bracket for the hose and install the hose.

STEP 92

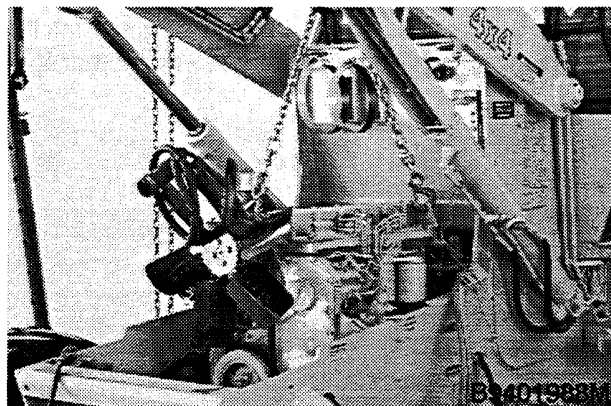

Disconnect and remove the lifting equipment from the engine.

STEP 93

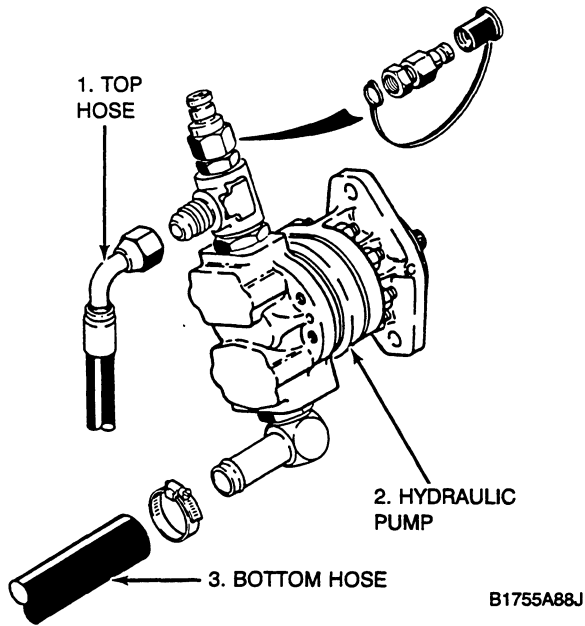

Remove the plug from the hose and the cap from the fitting and connect the bottom hose to the hydraulic pump.

STEP 94

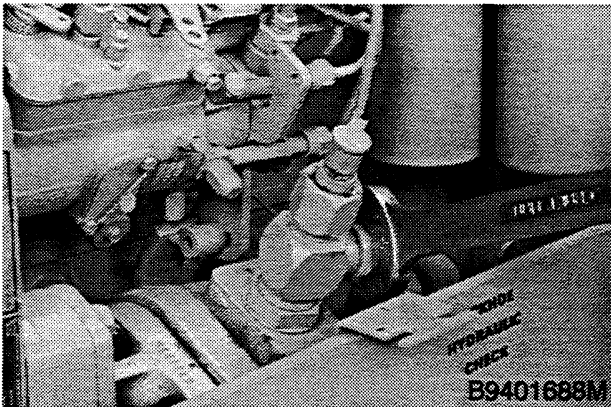

Remove the plug from the hose and the cap from the fitting and connect the top hose to the hydraulic pump.

STEP 95

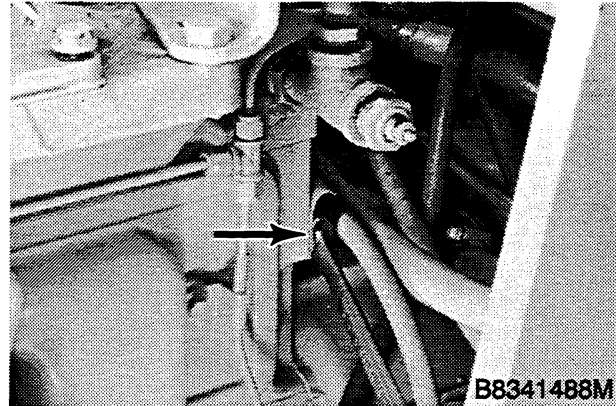

Install the cap screw, lock washer, and clamp that fasten the hose to the rear of the engine. Tighten the cap screw.

STEP 96

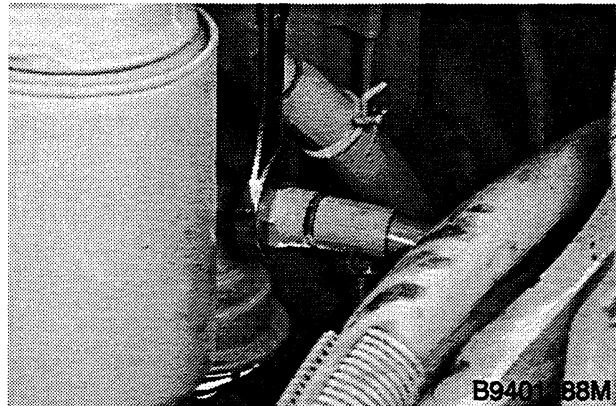

Remove the plug from the hose and the cap from the fitting and connect the fuel supply line to the hand primer pump.

STEP 97

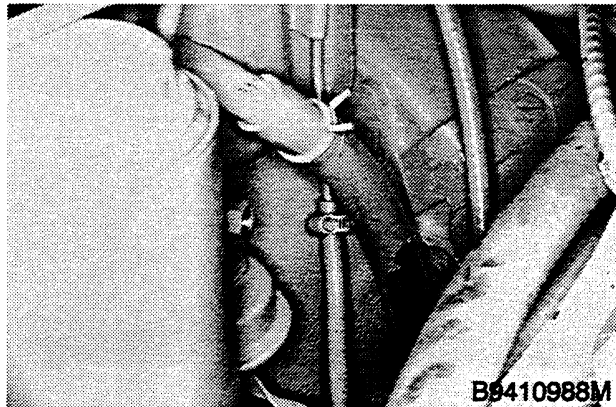

Remove the plug from the hose and the cap from the tube and connect the hose to the fuel return line. Tighten the clamp for the hose. Open the shutoff valve for the fuel line at the bottom of the fuel tank.

STEP 98

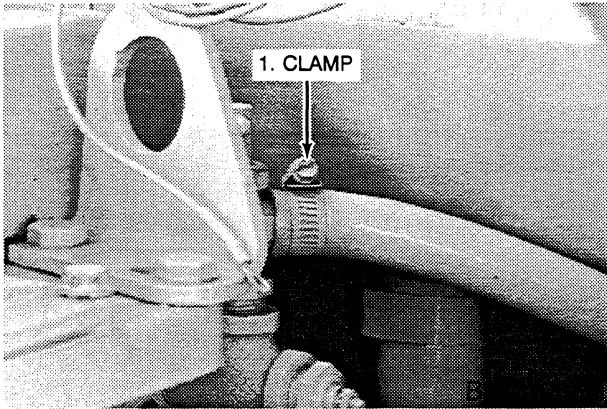

Remove the plug from the hose and connect the heater hose. Tighten the clamp for the hose.

STEP 99

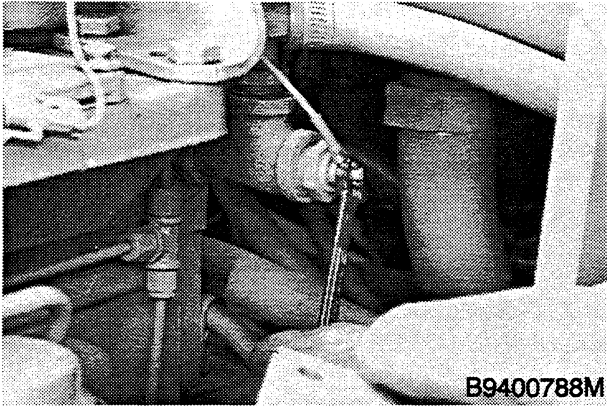

Connect the wire for the heater temperature switch.

STEP 100

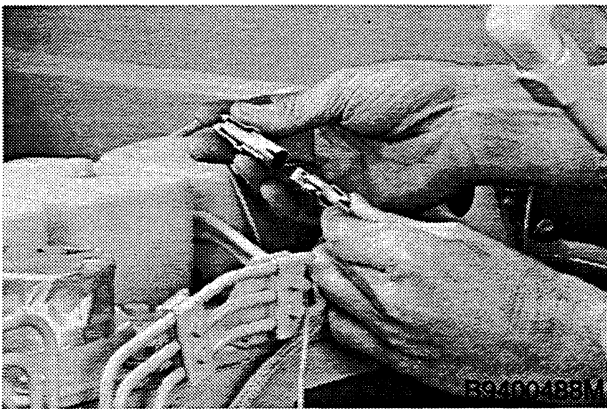

If the machine is equipped with ether injection, connect the wiring to the connector for the temperature switch.

STEP 101

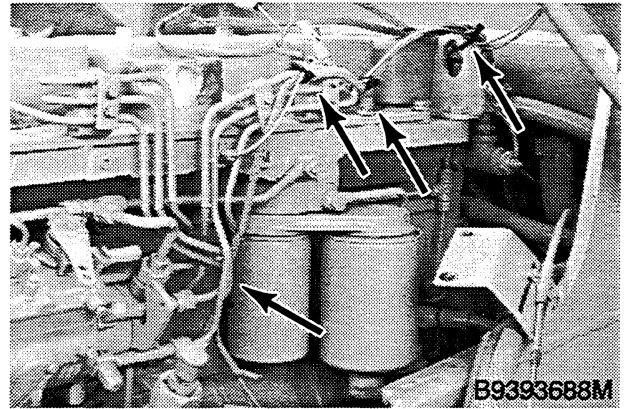

Install new tie straps to fasten the wire harness and the tube for the ether injection, if equipped.

STEP 102

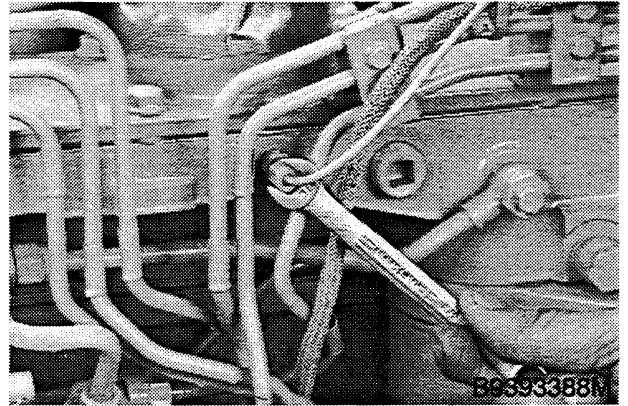

If the machine is equipped with ether injection, connect the tube to the intake manifold.

STEP 103

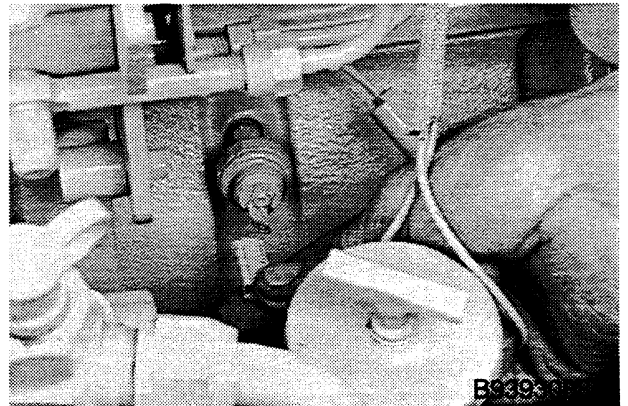

Connect the wire harness to the oil pressure switch.



Suggest:

If the above button click is invalid.

Please download this document

first, and then click the above link

to download the complete manual.

Thank you so much for reading

STEP 104

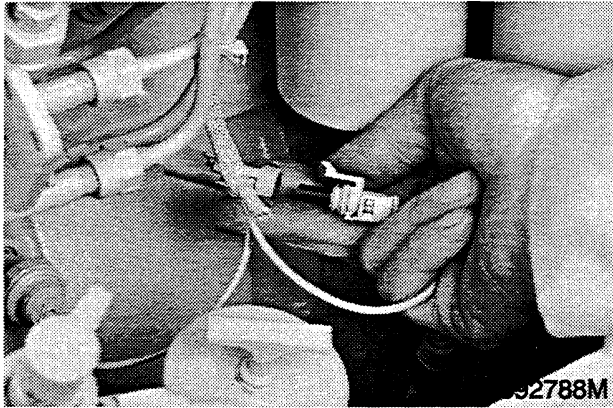

Connect the wiring to the connector for the fuel injection solenoid on the fuel injection pump.

STEP 107

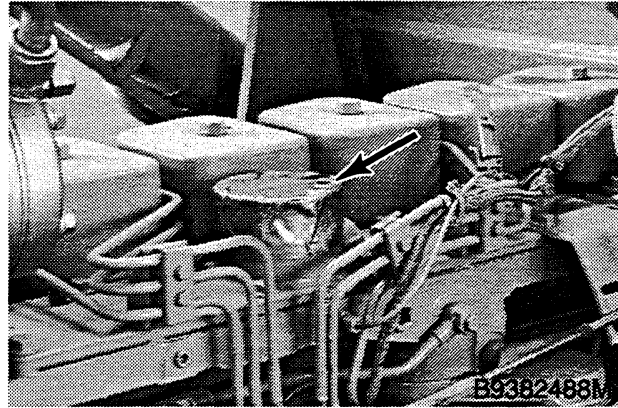

Remove the tape from or uncover the opening in the intake manifold.

STEP 105

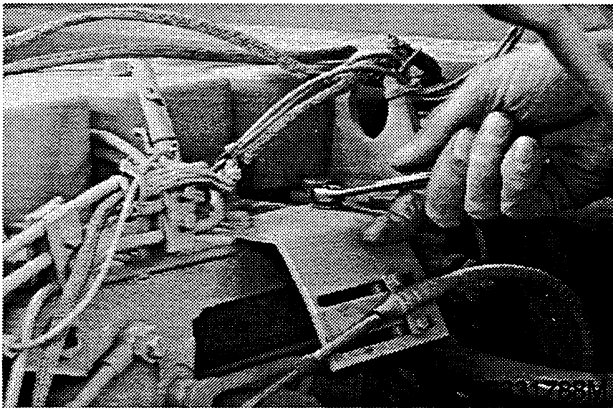

Install the bracket for the throttle cable to the engine. Install and tighten the cap screws that fasten the bracket.

STEP 108

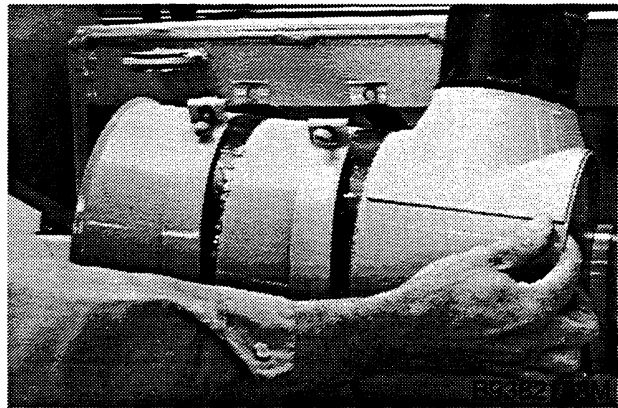

Install the air cleaner.

STEP 106

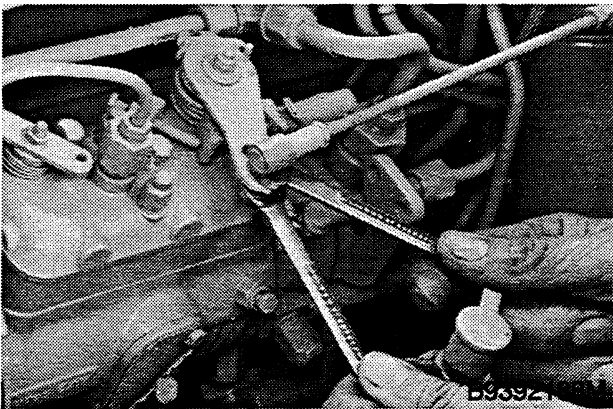

Connect the throttle cable to the arm on the fuel injection pump.

STEP 109

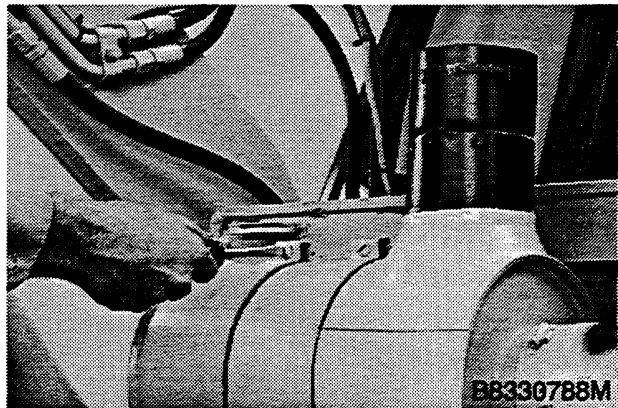

Install the screws and nuts that fasten the air cleaner in the mounting straps. Tighten the screws.

<https://www.ebooklibonline.com>

Hello dear friend!

Thank you very much for reading.

Enter the link into your browser.

The full manual is available for immediate download.

<https://www.ebooklibonline.com>