

## 680CK SERIES E LOADER BACKHOE TABLE OF CONTENTS

SERIES/SECTION	SECTION NO.	FORM NO.
<b>10 GENERAL</b>		
General Engine Specifications .....	1010	9-77655
Maintenance and Lubrication .....	1050	9-73496
Torque Chart .....	1051	9-73495
<b>20 ENGINES</b>		
Engine Diagnosis .....	2001	9-76365
Engine Tune-up .....	2002	9-76379
Cylinder Head, Valve Train and Camshaft .....	2015	9-76166
Cylinder Block, Sleeves, Pistons and Rods .....	2025	9-76176
Crankshaft, Main Bearing, Flywheel and Oil Seal Replacement .....	2035	9-76187
Lubricating System .....	2047	9-78667
Stall Checks and Engine Removal and Installation .....	2050	9-73495
Air Cleaner .....	2051	9-73495
Cooling System .....	2055	9-76337
Reconditioning Engine Cylinder Block .....	2290	8-21170
<b>30 FUEL SYSTEM</b>		
Fuel System and Filters - Four and Six Cylinder "B" Series Diesel Engines .....	3010	9-75297
Robert Bosch Fuel Injection Pumps - Four and Six Cylinder "B" Series Diesel Engines .....	3012	9-74937
Rosa Master Fuel Injectors "B" Series Diesel Engines .....	3013	9-74959
Foot Throttle, Hand Throttle Fuel Shutoff Control, Fuel Lines and Fuel Tank .....	3052	9-73495
<b>40 HYDRAULICS</b>		
Hydraulic Diagrams, Troubleshooting Pressure Checks .....	4011	9-73495
Hydraulic Pump L55247 .....	4013	9-73495
Loader Control Valves - L55009 (2-Spool) and L55010 (3-Spool) .....	4021	9-73495
Backhoe Control Valve .....	4022	9-73495
Stabilizer Control Valve .....	4025	9-73495
L54772 and L59641 Backhoe Relief Valves, L54470 Flow Control Valve .....	4042	9-73495
Loader and Backhoe Cylinders .....	4057	9-73495
<b>50 STEERING</b>		
Steering Hydraulic System, Troubleshooting, Pressure Checks .....	5011	9-73495
Steering Valve and Steering Column .....	5013	9-73495
Steering Cylinders .....	5015	9-73495
Front Axle .....	5017	9-73495

**SERIES/SECTION****SECTION NO.****FORM NO.****60 POWER TRAIN**

Transmission/Converter Hydraulic Diagram, Operation and Description .....	6011	9-73495
Troubleshooting and Testing .....	6012	9-73495
Forward-Reverse Transmission (Power Shuttle) .....	6014	9-73495
Four Speed Mechanical Transmission .....	6018	9-73495
Differentials and Planetaries .....	6020	9-73495
Drive Shaft .....	6022	9-73495

**70 BRAKES**

Air System Diagrams, Operation Pressurizing/Depressurizing the Air System and Troubleshooting .....	7011	9-73495
Foot Brakes and Slack Adjuster .....	7013	9-73495
Air Compressor, Governor, Reservoir and Safety Valve .....	7014	9-73495
Brake Valve .....	7015	9-73495
Brake Actuator .....	7016	9-73495
Parking Brake Control Valve and Quick Release Valve .....	7017	9-73495
Pressure Reducing, Pressure Protection, Double Check, Clutch Cutout Valves and Stoplight Switch .....	7018	9-73495
Alcohol Evaporator .....	7020	9-73495

**80 ELECTRICAL**

Wiring Diagrams .....	8011	9-73495
Troubleshooting .....	8012	9-73495
Batteries .....	8014	9-73495
Starter and Starter Solenoid .....	8015	9-73495
Alternator .....	8016	9-73495

**90 MOUNTED EQUIPMENT**

Loader .....	9011	9-73495
Backhoe .....	9012	9-73495
Roll-Over Protection Structure .....	9019	9-73495

# Section 1010

## GENERAL ENGINE SPECIFICATIONS 680 CK Series E Loaders

THE MODEL AND ENGINE SERIAL NUMBER PLATE IS LOCATED ON THE RIGHT HAND SIDE OF THE ENGINE ABOVE THE CRANKING MOTOR.

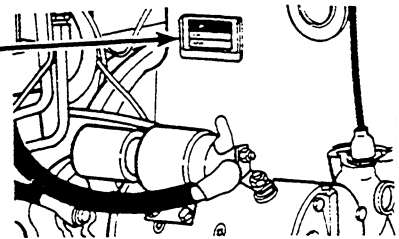

### General

### DIESEL ENGINES

Type .....	4 Cylinder, 4 Stroke Cycle, Valve-in-Head
Firing Order .....	1-3-4-2
Bore .....	4-5/8 Inches
Stroke .....	5 Inches
Piston Displacement .....	336 Cubic Inches
Compression Ratio .....	16.5 to 1
No Load Governed Speed .....	2330 to 2370 RPM
Rated Engine Speed .....	2200 RPM
Engine Idling Speed .....	700 to 750 RPM
*Valve Tappet Clearance (Exhaust) .....	(Hot) .020 Inch (Cold) .025 Inch
(Intake) .....	(Hot and Cold) .015 Inch

\*Hot Settings Are Made After The Engine Has Operated At Thermostat Controlled Temperature For At Least Fifteen Minutes.

### Piston and Connecting Rods

Rings per Piston .....	3
Number of Compression Rings .....	2
Number of Oil Rings .....	1
Type Pins .....	Full Floating Type
Type Bearing .....	Replaceable Precision, Steel Back, Copper-Lead Alloy Liners

### Main Bearings

Number of Bearings .....	5
Type Bearings .....	Replaceable Precision, Steel Back, Copper-Lead Alloy Liners

### Engine Lubricating System

Oil Pressure .....	45 to 60 Pounds with Engine Warm and Operating at Rated Engine Speed
Type System .....	Pressure and Spray Circulation
Oil Pump .....	Gear Type
Oil Filter .....	Full Flow Spin on Type
Oil Capacity With Filter .....	11 U.S. Quarts
Without Filter .....	10 U.S. Quarts

### Fuel System

Fuel Injection Pump .....	Robert Bosch, Type PES Multiple Plunger
Pump Timing .....	34 Degrees Before Top Dead Center (Port Closing)
Fuel Injectors .....	Pencil Type (Opening Pressure 3200 PSI)
Fuel Transfer Pump .....	Plunger Type, Integral Part of Injection Pump
Governor .....	Variable Speed, Fly-Weight Centrifugal Type, Integral Part of Injection Pump
1st Stage Fuel Filter .....	Full Flow Spin on Type
2nd Stage Fuel Filter .....	Full Flow Spin on Type

**<https://www.ebooklibonline.com>**

Hello dear friend!

Thank you very much for reading.

Enter the link into your browser.

The full manual is available for immediate download.

**<https://www.ebooklibonline.com>**

# **Section 1050**

**MAINTENANCE**

**AND**

**LUBRICATION**

## FUEL, FLUIDS AND LUBRICANTS

COMPONENT	CAPACITY		SPECIFICATIONS
	U.S.	Metric	
Fuel tank	30 gallons	113.5 liters	
Engine crankcase oil			
With filter change	11 quarts	10.4 liters	Engine oil: Case HDM oil (CD Commercial class D) MIL-L-45199B Above 32° F (0° C) . . . . . SAE 30 10° to 50° F (-12° to 10° C) SAE 20W Below 40° F (4° C) . . . . . SAE 10W
Without filter change	10 quarts	9.5 liters	
Hydraulic system			
Total	35 gallons	133 liters	Case TCH Fluid Alternate oils Engine oil - SD - Service class D or CA - Commercial class A Above 32° F (0° C) . . . . SAE 10W Below 32° F. (0° C) . . . SAE 5W  Type C-2 Transmission and hydraulic fluid such as Tenneco Hytrans Fluid.
Reservoir refill	13.8 gallons	52.2 liters	
Forward/Reverse transmission refill	12 quarts	11.4 liters	Case TCH Fluid
Synchromesh transmission	6.4 pints	3.0 liters	Case FDL Multipurpose Gear Lubricant or (SAE 90, API-GL-4, MIL-L-2105B)
Rear Axle			
Center bowl	13.5 quarts	12.8 liters	Hypoid Gear Oil, API-GL-5 SAE 90 or SAE 80W/90 - -15° F. (-26° C) and above SAE 80W - -15° F. (-26° C) to +70° F. (+21° C) SAE 75W - -40° F. (-40° C) to +35° F. (+2° C)
Planetaries - each	3 pints	1.4 liters	
Cooling System	32 quarts	30.2 liters	Ethylene glycol type antifreeze and water should be mixed for prevailing temperatures. Follow manufacturer's specifications.
Alcohol evaporator	1 pint	0.5 liters	Clean wood alcohol
Batteries	As required		Add colorless, odorless drinking water.
Grease fittings	As required		No. 2 moly disulfide grease  Alternate grease: Multipurpose lithium-soap base grease.
Wheel bearings	As required		Number 2 wheel bearing grease.

## RUN-IN MAINTENANCE CHART

**NOTE:** The following charts are based on maximum intervals. If the machine operates in severe conditions, service more often.

**NOTE:** See page 1050-2 for a listing of fluids and lubricants.

INTERVAL	SERVICE	INSTRUCTIONS
Every Two Hours Until Stabilized	<p>Check wheel nut and bolt torque. Front - 170 foot-pounds torque. Rear - 220-240 foot-pounds torque.</p> <p>Check rear axle mounting bolts. 320-420 foot-pounds torque.</p> <p>Check swing cylinder plate mounting bolts. 500 foot-pounds torque.</p> <p>Check upper swing tower pivot pin nut. 1000 foot-pounds torque.</p>	<p>Section 9012.</p> <p>Section 9012.</p>
After First 20 Hours	<p>Change engine crankcase oil.</p> <p>Replace engine oil filter.</p> <p>Check drive belt tension.</p> <p>Service fuel system.</p>	<p>Section 2047.</p> <p>Section 8016.</p> <p>Section 3010.</p>

## SCHEDULED MAINTENANCE CHART

INTERVAL	SERVICE	INSTRUCTIONS
Every 10 Hours or Daily Whichever Occurs First	<p>Grease loader and backhoe pivot points.</p> <p>Check engine crankcase oil level.</p> <p>Check hydraulic oil level.</p> <p>Check radiator coolant level.</p> <p>Drain moisture from air reservoir.</p> <p>Grease inner Extendahoe dipper.</p> <p>Grease front axle pivots.</p> <p>Check machine and ground under it for leaks.</p> <p>Check fuel sediment bowl for water or sediment. If found, drain bowl, 1st stage filter and fuel tank.</p>	<p>Section 7011.</p> <p>Section 3010.</p>

INTERVAL	SERVICE	INSTRUCTIONS
Every 50 Hours or Weekly, Whichever Occurs First	Grease steering king pins. Grease driveshaft universals and slip spline. Check battery electrolyte level. Check Forward/Reverse transmission oil level. Grease brake shafts and slack adjusters. Check tire pressures.	Section 6014. Section 7013. Section 5011.
Every 150 Hours	Change engine oil.	
Every 250 Hours	Check rear axle oil level. Check synchromesh transmission oil level. Clean alcohol evaporator filter. Grease seat post. Lubricate shuttle control lever. Grease loader and backhoe control lever grease fittings.	Section 6020. Section 6018. Section 7020.
Every 300 Hours	Replace engine oil filter.	Section 2047.
Every 500 Hours	Drain deposits from fuel tank. Check drive belt tension. Change fuel filters. Check ROPS as indicated. Repack front wheel bearings.	Sections 7014, 8016 Section 3010. Section 9019. Section 5017.
Every 1000 Hours or Yearly, Whichever Occurs First	Change hydraulic reservoir oil. Replace hydraulic oil filter. Clean hydraulic filter by-pass screen. Change forward/reverse transmission oil. Clean forward/reverse transmission suction screen.	Section 6014. Section 6014.

INTERVAL	SERVICE	INSTRUCTIONS
Every 1000 Hours or Yearly, Whichever Occurs First (Cont'd)	Change synchromesh transmission oil. Change rear axle oil. Clean air compressor cylinder head (by dealer only).	Section 6018. Section 6020. Section 7014.
Every 2000 Hours or Yearly, Whichever Occurs First	Disassemble and clean alcohol evaporator (by dealer only). Drain, flush and refill cooling system.	Section 7020.
Every 3000 Hours	Rebuild or replace air compressor (by dealer only).	Section 7014.
As Required	Service air cleaner element when restriction indicator shows red band. After wheel has been removed for service and reinstalled, check wheel nut/bolt torque every two hours until stabilized. Replace fire extinguisher shell. Fill alcohol evaporator with clean wood alcohol. Check the over-the-center boom stop pad for deterioration. Replace as required. The pad bolt torque is 9 foot-pounds.	Section 2051. Section 9012.

# **Section 2001**

## **ENGINE DIAGNOSIS**

## GENERAL INFORMATION

Before making any repairs or adjustments on an engine, a mechanic or technician must properly diagnose the trouble.

Locating the trouble and repairing it is only part of the job, a technician must find and eliminate the cause of the trouble as well. Too many repairs are made with no thought to removing the causes that made the repair necessary.

For any engine to start or perform properly, three main requirements must be present.

1. FUEL
2. COMPRESSION
3. IGNITION

When any of these requirements are not present or limited by some mechanical reason the engine will not start or fails to operate properly throughout the power range.

1. FUEL. Fuel system problems can be present anywhere from the fuel tank, through the filters and injection pump as well as the injectors. Correct injection pump timing is important in the overall fuel system performance.

2. COMPRESSION. Compression on an engine is related to the "breathing function".

Proper compression is affected by the air cleaner condition, muffler restriction, valve condition and operation including proper valve adjustment, cylinder head gaskets condition of sleeves, rings, pistons, camshaft, and camshaft timing.

3. IGNITION. Ignition is the result of adequate compression to develop enough heat in the air charge on the compression stroke to fire the fuel being injected into the engine cylinders. Proper spray pattern and atomization of the fuel by the injector is very important. Timing the fuel injection pump to the engine to a precise degree BTDC is a vital requirement for proper ignition.

The engine diagnosis contained in the following pages covers many trouble symptoms, the causes, and what will be necessary to repair or eliminate the problem. Under each symptom are listed the most common and re-occurring problems progressively to the not so common problems. Locate your problem symptom in the diagnosis chart and refer to the pages listed for the probable causes and remedies.

# INSTALLATION INSTRUCTIONS FOR M20614 TEFLON VALVE SEAL KIT

## Special Tools Required

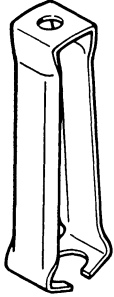

M20624 SEAL INSTALLATION TOOL

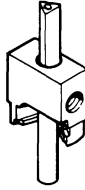

M20617 VALVE GUIDE CUTTING TOOL

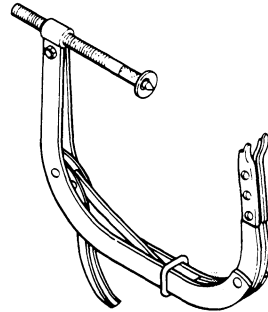

VALVE SPRING COMPRESSOR

NOTE: FOUR CYLINDER ENGINES REQUIRE TWO M20614 KITS AND SIX CYLINDER ENGINES REQUIRE THREE M20614 KITS.

### STEP 1

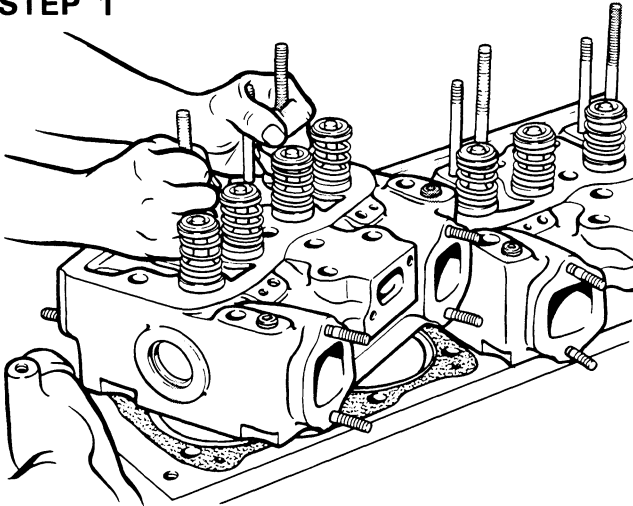

REMOVE THE CYLINDER HEADS FROM THE ENGINE, REFER TO SECTION 2015 FOR HEAD REMOVAL.

### STEP 2

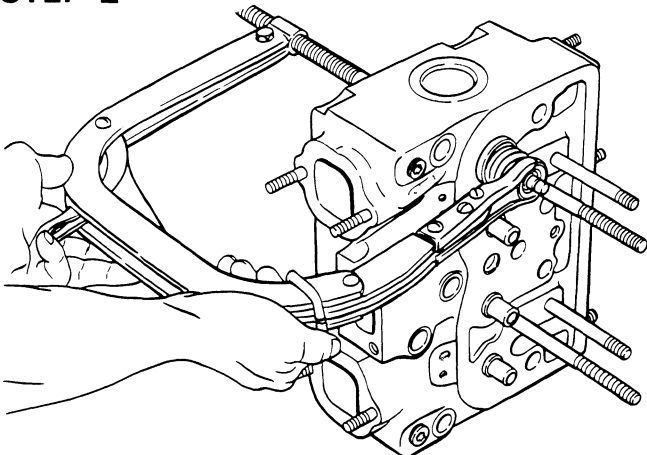

INSTALL A VALVE SPRING COMPRESSOR.

### STEP 3

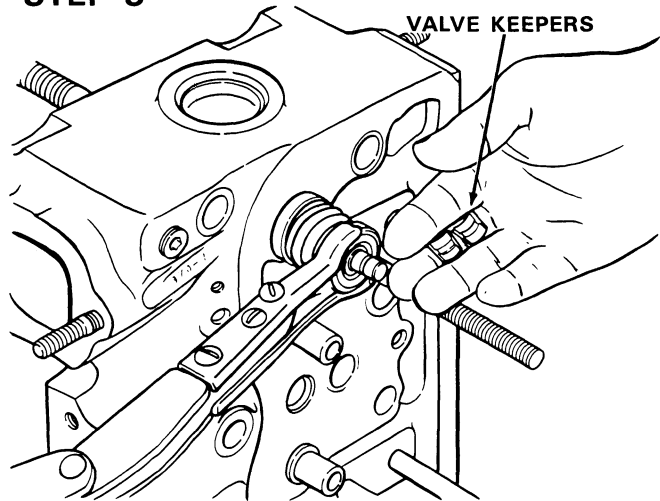

COMPRESS VALVE SPRING AND REMOVE VALVE KEEPERS.

IMPORTANT: VALVES, VALVE RETAINERS OR ROTATORS AND VALVE KEEPERS SHOULD BE MARKED WHEN REMOVED, TO INSURE THAT THEY WILL BE REINSTALLED IN THEIR ORIGINAL LOCATION.

### STEP 4

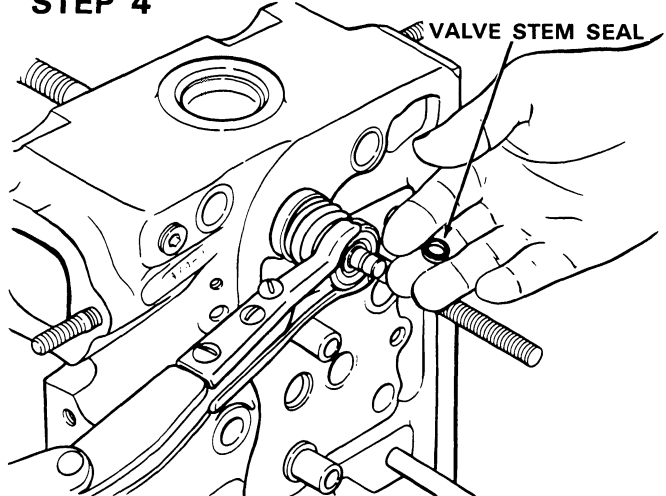

REMOVE VALVE STEM SEAL.

**STEP 5**

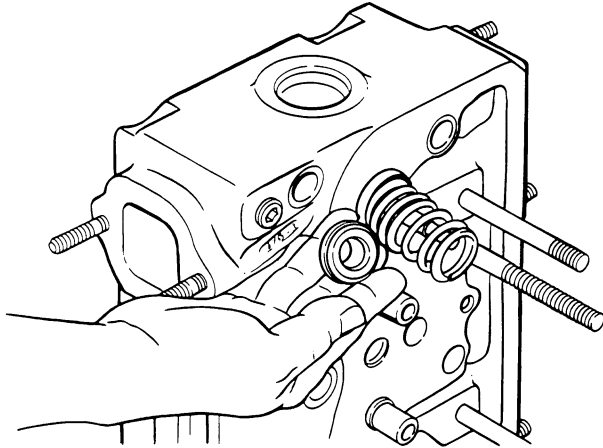

**REMOVE VALVE ROTATORS OR SPRING RETAINERS, SPRINGS, SPRING SEATS AND VALVES.**

**STEP 6**

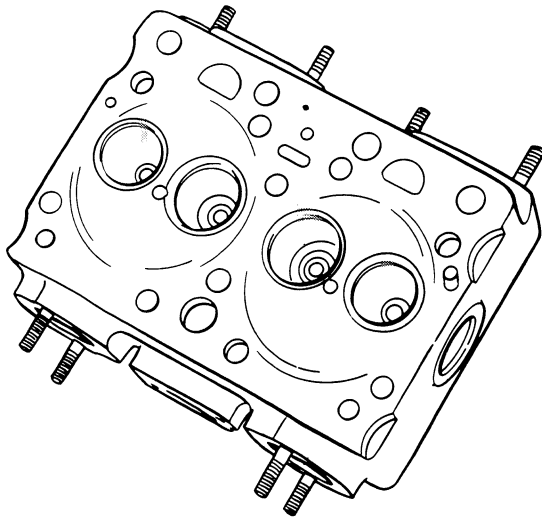

**CLEAN CYLINDER HEAD COMPLETELY, REMOVING ALL TRACES OF CARBON AND OTHER DEPOSITS.**

**STEP 7**



**CLEAN VALVES WITH A FINE POWER DRIVEN WIRE BRUSH, REMOVING ALL CARBON AND VARNISH DEPOSITS. BE CAREFUL NOT TO SCRATCH VALVE STEMS.**

**STEP 8**

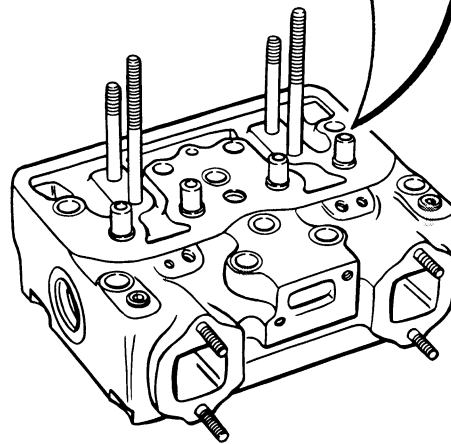
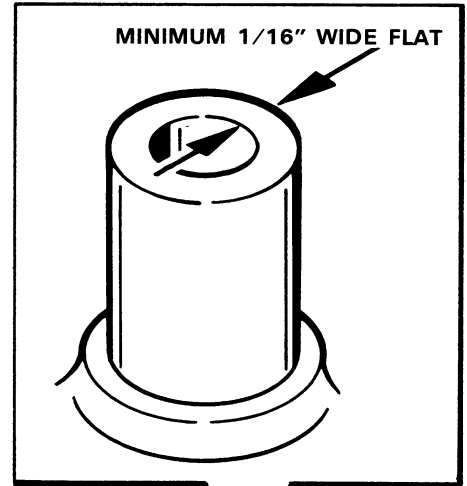

**CHECK VALVE GUIDE TOP SURFACE, THERE MUST BE A MINIMUM OF A 1/16\"/>A line drawing of a cylinder head with valve guides, showing the top surface of the valve guides. A callout box from the previous image points to the top surface of one of the valve guides.**

**STEP 9**

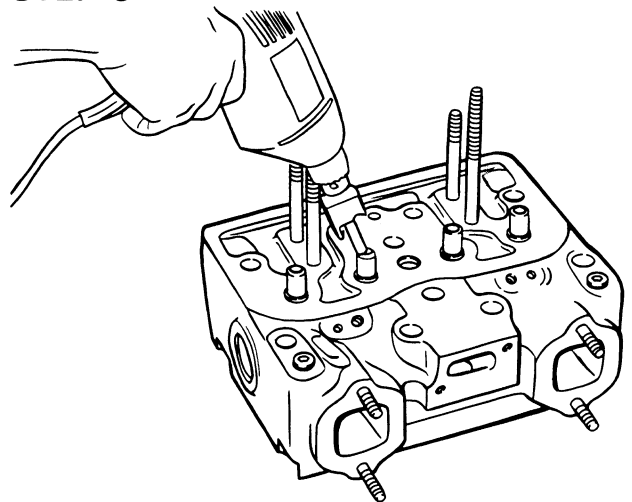

**USE M20617 TOOL IN A ELECTRIC DRILL (IF REQUIRED) TO PROVIDE NECESSARY FLAT AREA ON VALVE GUIDE. IMPORTANT: DO NOT EXCEED 450 RPM WHEN DRILLING**

**STEP 10**

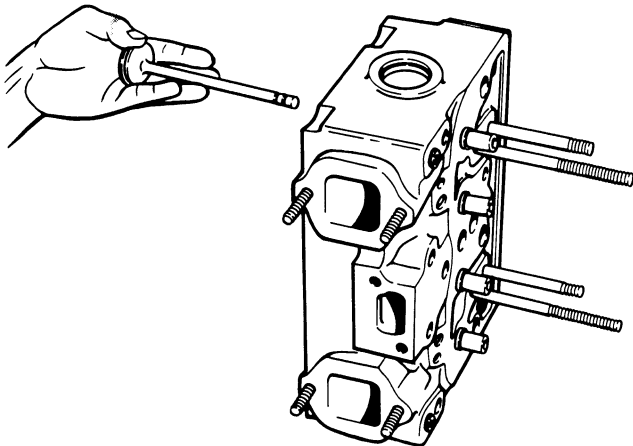

LUBRICATE VALVES WITH CLEAN ENGINE OIL BEFORE REINSTALLING INTO CYLINDER HEAD.

**STEP 11**

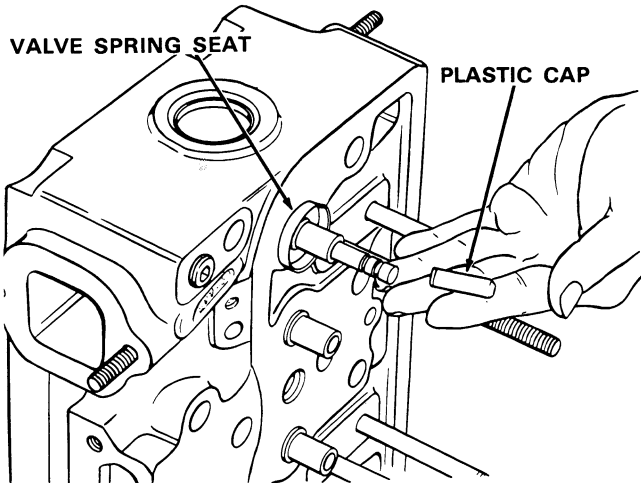

PLACE PLASTIC INSTALLATION CAP, PROVIDED IN KIT, ON THE END OF THE VALVE STEM. NOTE: CAP PREVENTS SHARP EDGES ON VALVE STEM GROOVES FROM CUTTING VALVE SEAL.

**STEP 12**

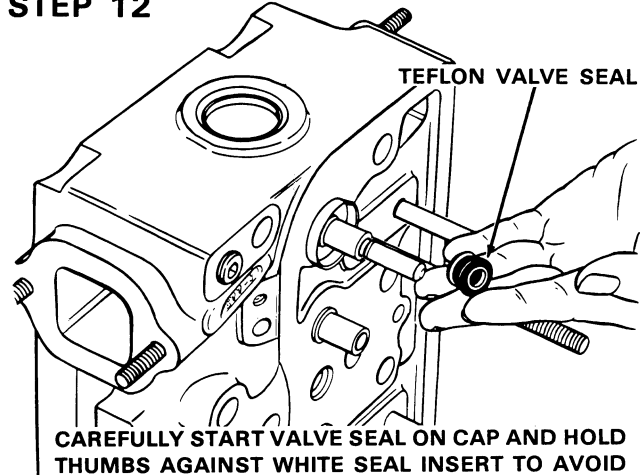

CAREFULLY START VALVE SEAL ON CAP AND HOLD THUMBS AGAINST WHITE SEAL INSERT TO AVOID DISLODGING IT, PUSH SEAL DOWN UNTIL SEAL JACKET TOUCHES TOP OF VALVE GUIDE. REMOVE INSTALLATION CAP AND SAVE, SINCE IT MUST BE REUSED.

**STEP 13**

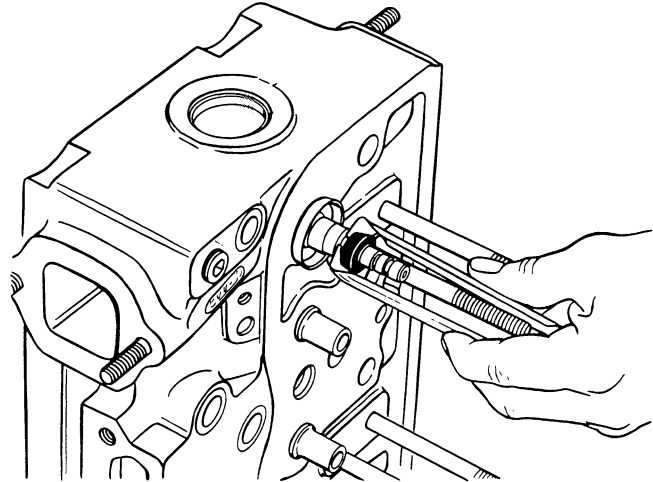

USE M20624 TOOL AND PRESS SEAL DOWN OVER VALVE GUIDE UNTIL SEAL IS FLUSH WITH TOP OF GUIDE.

**STEP 14**

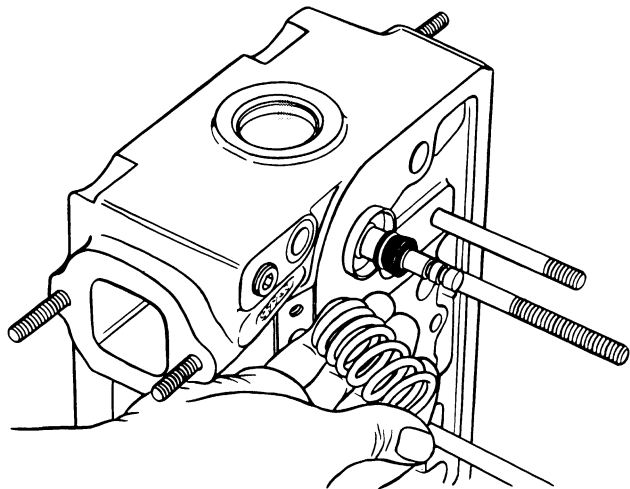
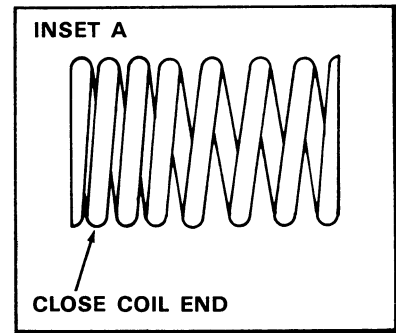

INSTALL THE VALVE SPRING. IMPORTANT: THE CLOSE COIL END OF THE SPRING MUST BE INSTALLED TOWARDS THE CYLINDER HEAD, SEE INSET A.

**STEP 15**

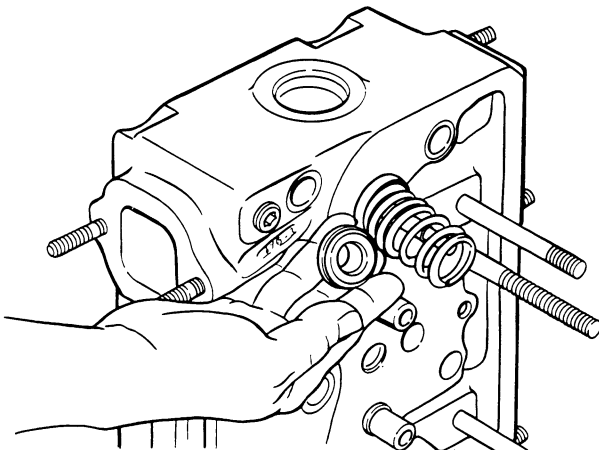

**INSTALL VALVE ROTATORS OR SPRING RETAINERS. IMPORTANT: ASSEMBLE VALVE ROTATORS WITH THEIR ORIGINAL VALVES SINCE THEY TEND TO WEAR IN AS A MATCHED SET.**

**STEP 16**

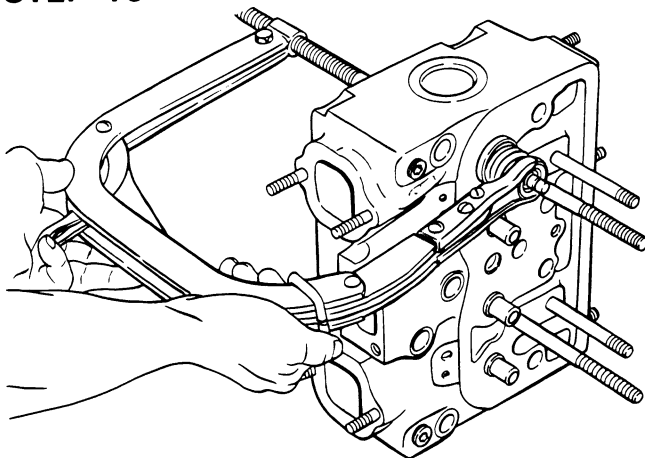

**INSTALL VALVE SPRING COMPRESSOR.**

**STEP 17**

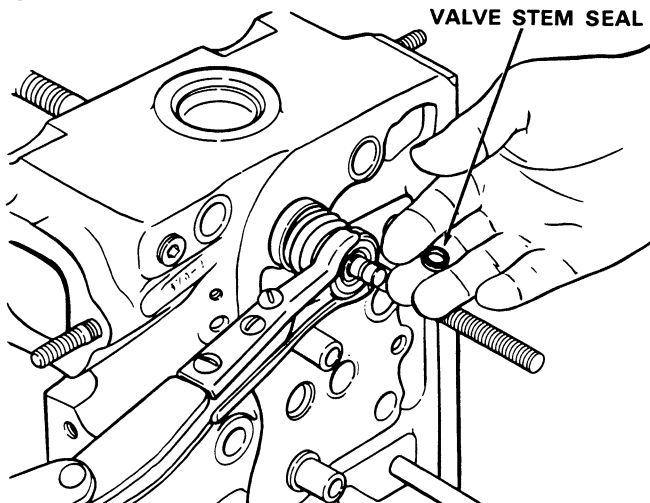

**INSTALL STEM SEAL IN LOWER VALVE STEM GROOVE.**

**STEP 18**

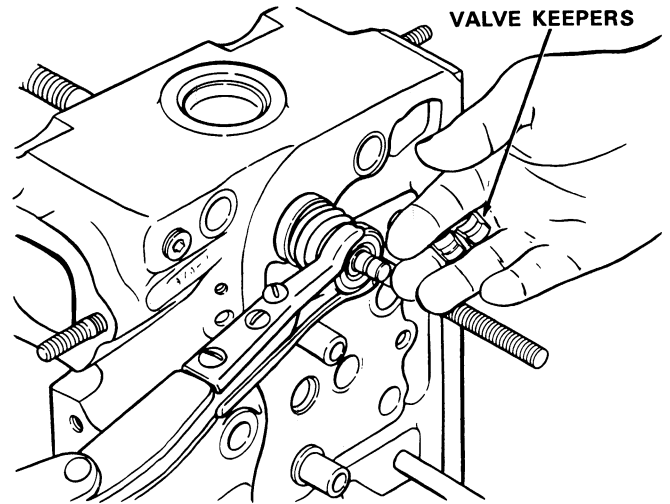

**INSTALL VALVE KEEPERS IN OUTER VALVE STEM GROOVE.**

**STEP 19**

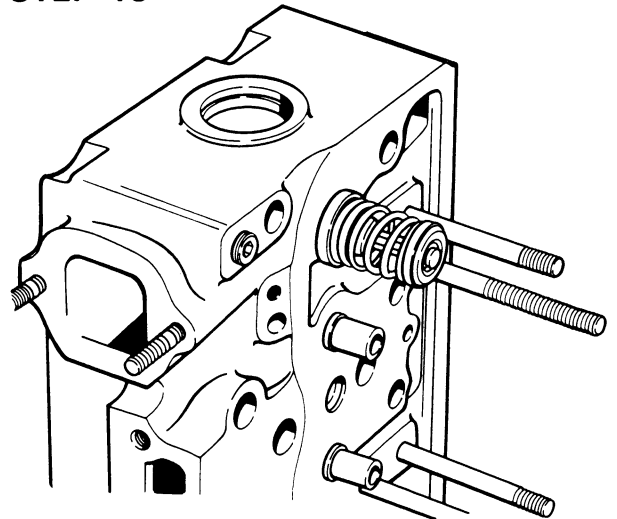

**REMOVE SPRING COMPRESSOR AND TAP VALVE STEM END TO SEAT KEEPERS.**

**STEP 20**

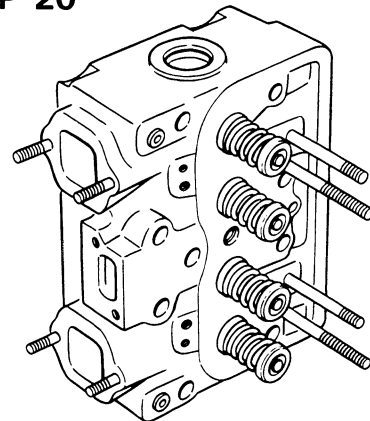

**INSTALL TEFLON SEALS ON THE OTHER INTAKE AND EXHAUST VALVES, FOLLOWING THE PRECEDING PROCEDURE.**

**STEP 21**

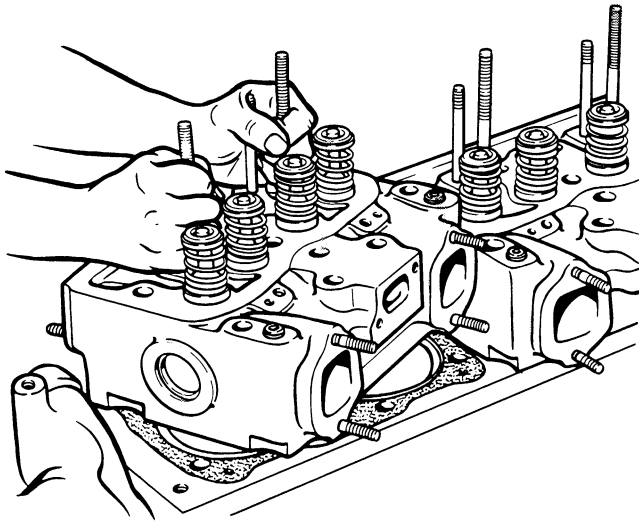

**REINSTALL CYLINDER HEAD ON ENGINE FOLLOWING PROCEDURE OUTLINED IN SECTION 2015.**

**NOTE:** The CASE CORPORATION reserves the right to make improvements in design or changes in specifications at any time without incurring any obligation to install them on units previously sold.

# ENGINE TUNEUP PROCEDURE

## Checking Crankshaft Damper Pulley

### STEP 1

THE RECOMMENDED CHANGE INTERVAL FOR THE CRANKSHAFT DAMPER PULLEY IS 2000 HOURS MAXIMUM. AT ANY TIME OVER 1500 HOURS. CONSIDER CHANGING PULLEY AT ANY MAJOR ENGINE OVERHAUL OR TUNE UP.

EVERY 500 HOURS AND AT ENGINE TUNEUP, VISUALLY INSPECT RUBBER ELEMENT FOR PEEL AREAS OR RUBBER MISSING. CHECK ALIGNMENT OF THE "V" MARKS BETWEEN THE INNER AND OUTER MEMBERS. IF "V" MARKS SHIFT, ENGINE TIMING WILL BE OFF AND DAMPER PULLEY MUST BE REPLACED.

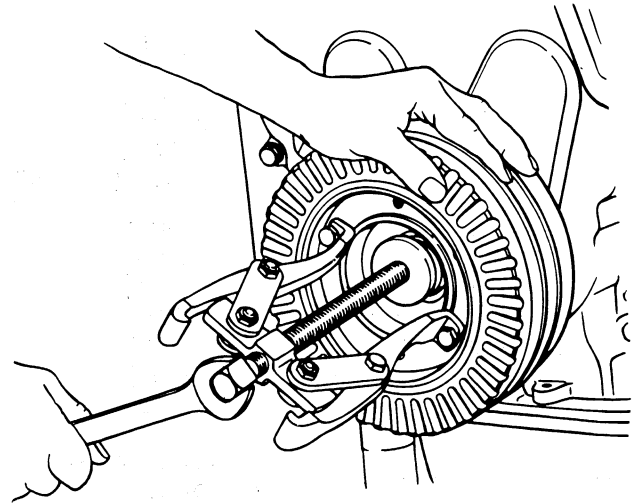
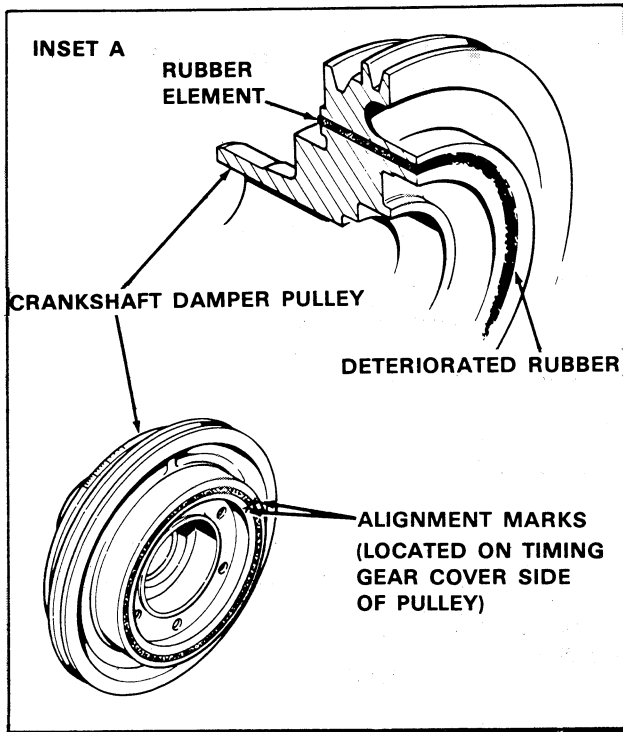
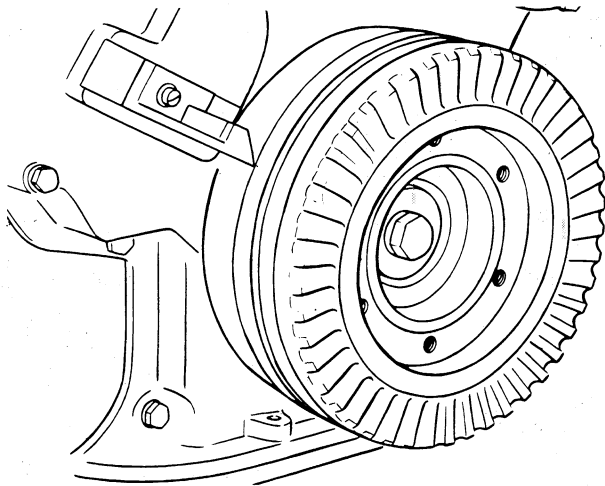

USE BOLT ON TYPE PULLER TO REMOVE PULLEY. REMOVE VISCOUS DAMPER FROM PULLEY (IF SO EQUIPPED). DO NOT PULL OR HAMMER ON OUTSIDE OF PULLEY OR VISCOUS DAMPER; SERIOUS DAMAGE TO PULLEY, DAMPER, AND RUBBER SLEEVE COULD RESULT.

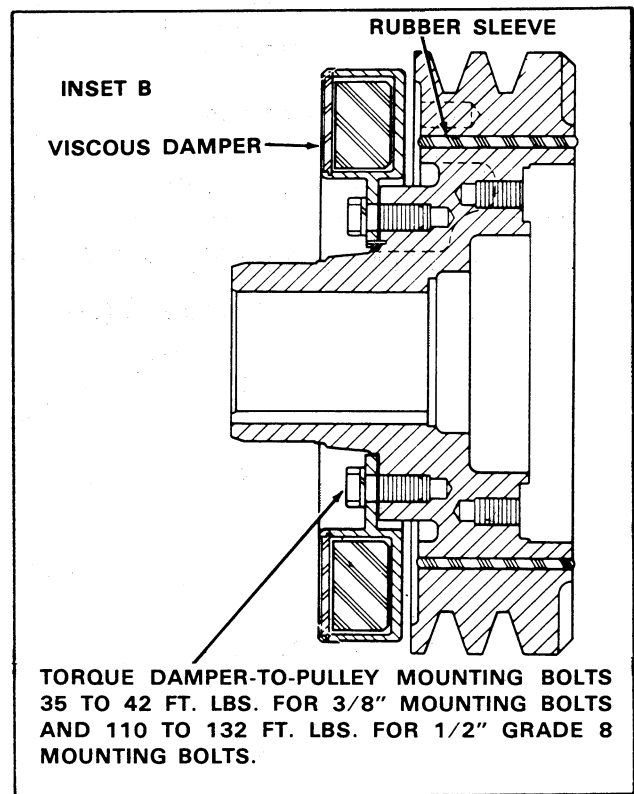

## Checking Top Dead Center

### STEP 2

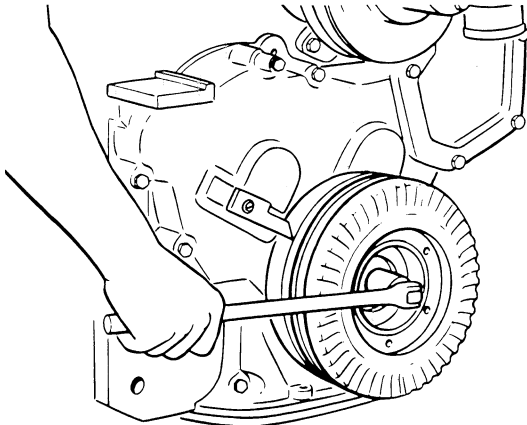

CRANK ENGINE UNTIL 10° BTDC MARK ON CRANK-SHAFT PULLEY IS ALIGNED WITH TIMING POINTER.

---

### STEP 3

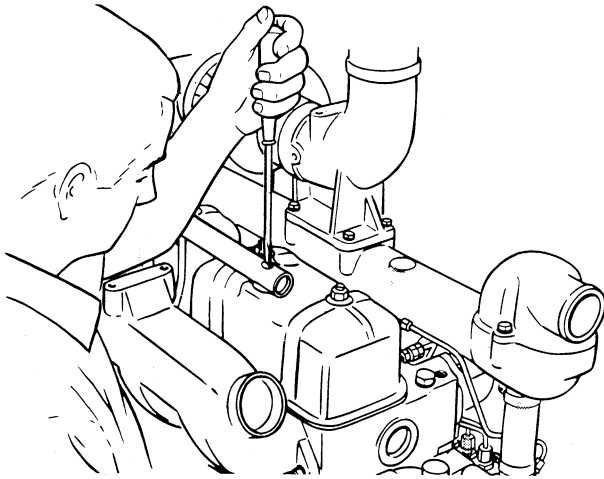

REMOVE BREATHER TUBE.

---

### STEP 4

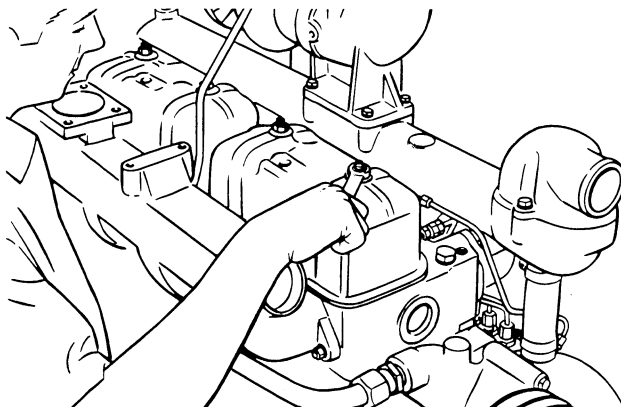

REMOVE VALVE COVER AND GASKET FROM NO. 1 AND NO. 2 CYLINDERS.

---

### STEP 5

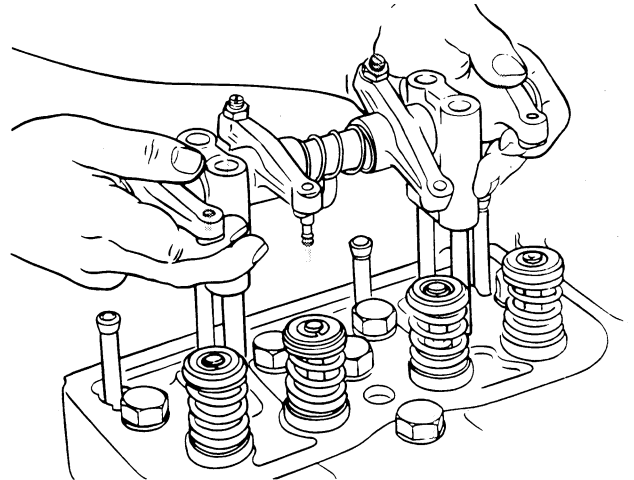

REMOVE ROCKER ARM ASSEMBLY.

---

### STEP 6

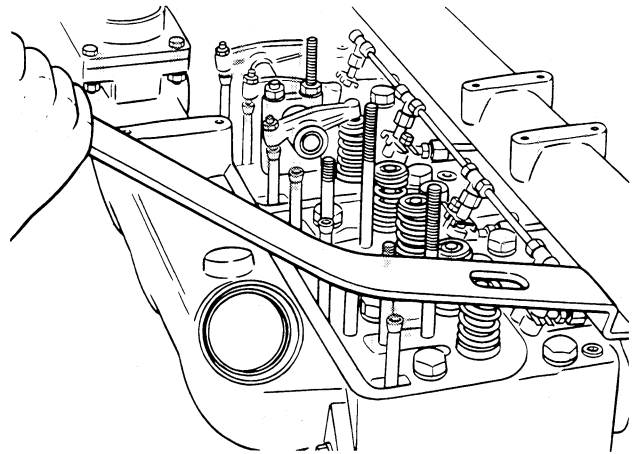

COMPRESS EXHAUST VALVE SPRING ON NO. 1 CYLINDER USING FABRICATED TOOL (SEE PAGE 3).

---

### STEP 7

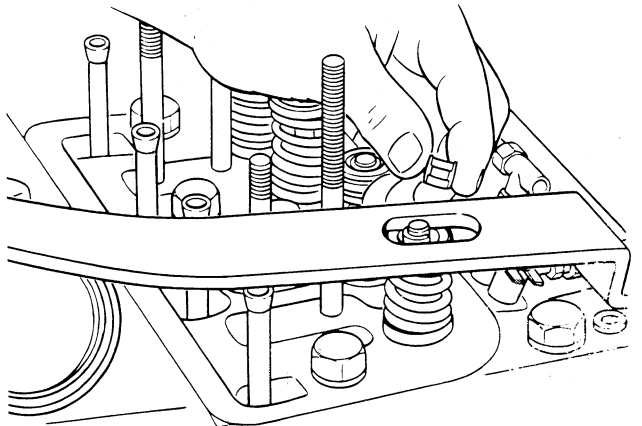

REMOVE VALVE KEEPERS

**STEP 8**

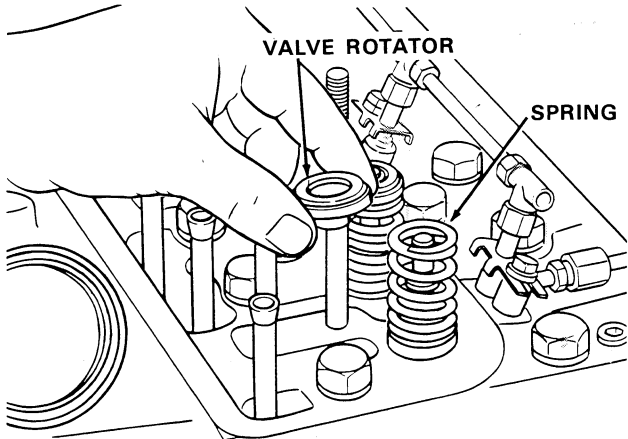

REMOVE VALVE ROTATOR, SPRING AND SEAT.

**STEP 9**

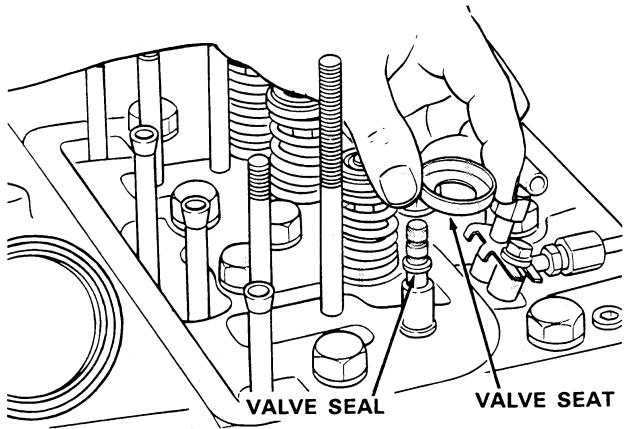

KEEP VALVE SEAL IN PLACE TO PREVENT VALVE FROM FALLING THROUGH VALVE GUIDE IF PISTON IS MOVED TOO FAR

**STEP 10**

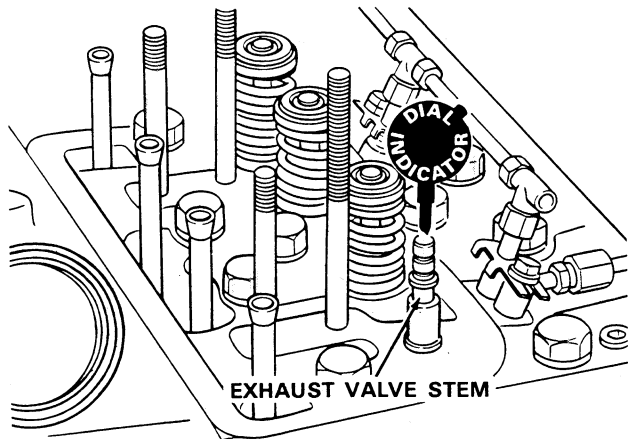

INSTALL DIAL INDICATOR ON END OF VALVE STEM WITH VALVE RESTING ON TOP OF PISTON.

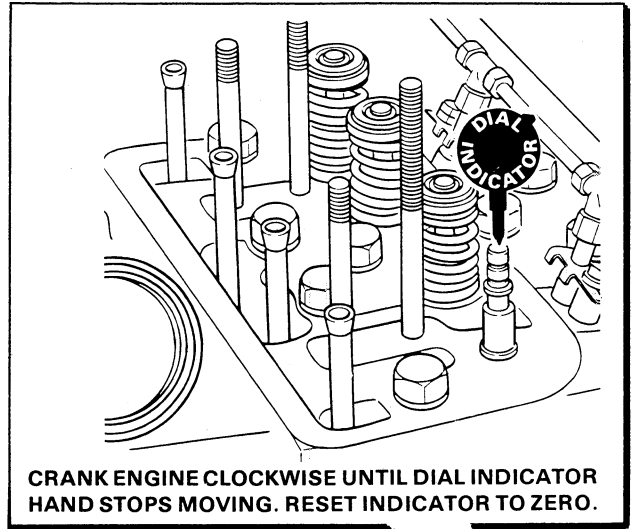

CRANK ENGINE CLOCKWISE UNTIL DIAL INDICATOR HAND STOPS MOVING. RESET INDICATOR TO ZERO.

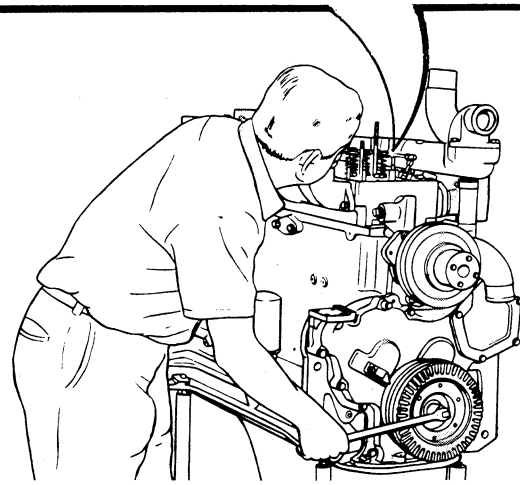

CRANK ENGINE CLOCKWISE UNTIL .010" SHOWS ON DIAL. SCRIBE A MARK ON CRANKSHAFT PULLEY IN LINE WITH TIMING POINTER.

CRANK ENGINE COUNTERCLOCKWISE PAST ZERO MARK ON INDICATOR UNTIL .010" SHOWS ON DIAL. AGAIN, SCRIBE MARK ON CRANKSHAFT PULLEY.

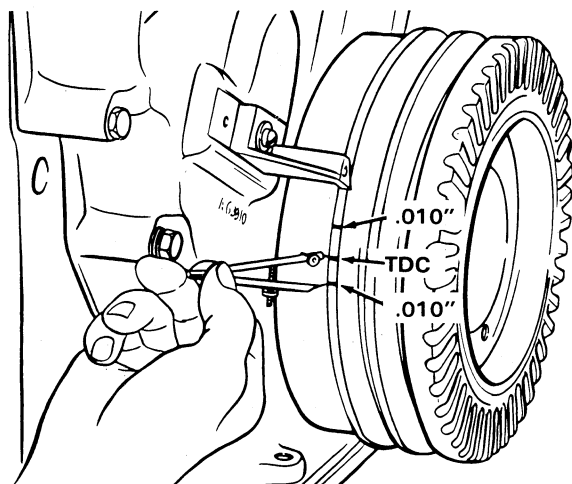
**STEP 11**

HALF THE DISTANCE BETWEEN THESE TWO SCRIBE MARKS ON CRANKSHAFT PULLEY WILL BE THE TOP DEAD CENTER (TDC) MARK. IF THE SCRIBE MARKS ARE NOT THE SAME AS ORIGINAL MARKS ON PULLEY CHECK DAMPER.

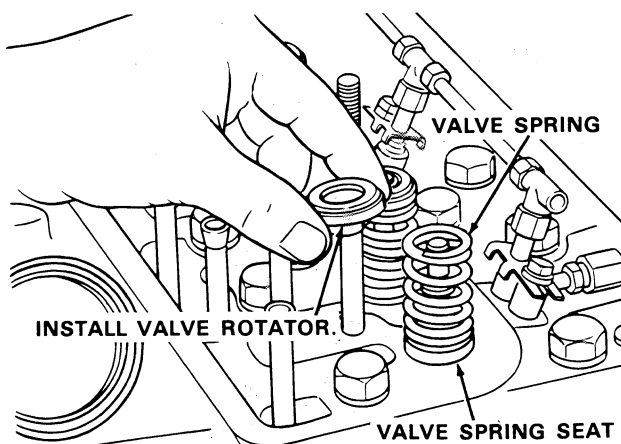
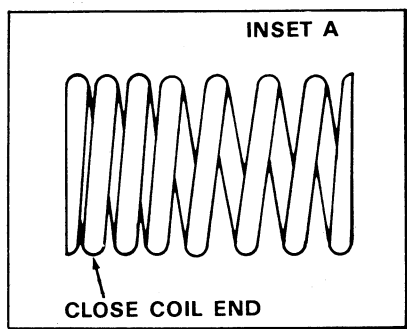
**STEP 12**

INSTALL SPRING SEAT AND VALVE SPRING. **NOTE:** IF EQUIPPED WITH VALVE SPRING HAVING ONLY ONE CLOSE COIL END, PLACE THIS END TOWARD CYLINDER HEAD, SEE INSET A.

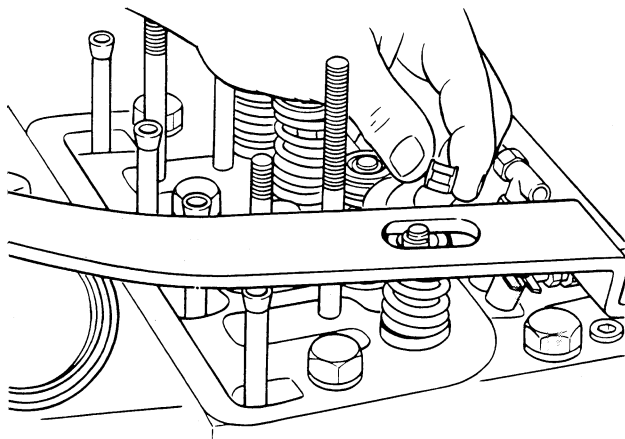
**STEP 13**

COMPRESS VALVE SPRING USING FABRICATED TOOL. INSTALL SEAL IN LOWER VALVE STEM GROOVE. INSTALL VALVE KEEPERS IN OUTER VALVE STEM GROOVE.

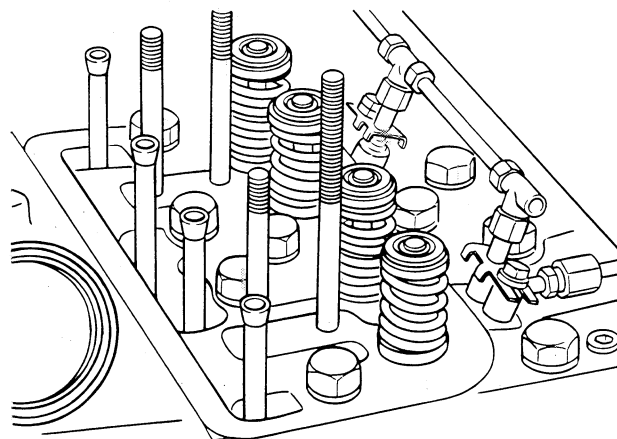
**STEP 14**

REMOVE SPRING COMPRESSING TOOL. TAP END OF VALVE STEM TO SEAT KEEPERS.

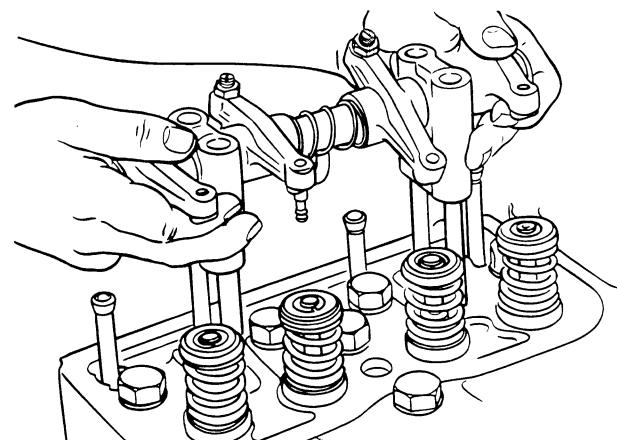
**STEP 15**

INSTALL ROCKER ARM ASSEMBLY ONTO CYLINDER HEAD.

**STEP 16**

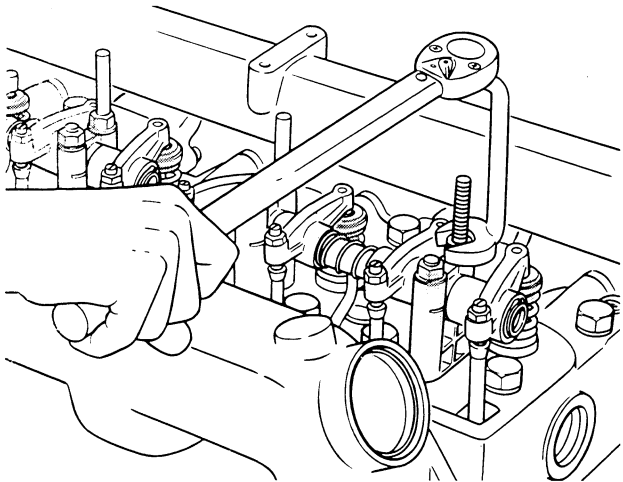

**TORQUE ROCKER ARM ASSEMBLY RETAINING NUTS  
40 TO 45 FT. LBS.**

---

**STEP 17**

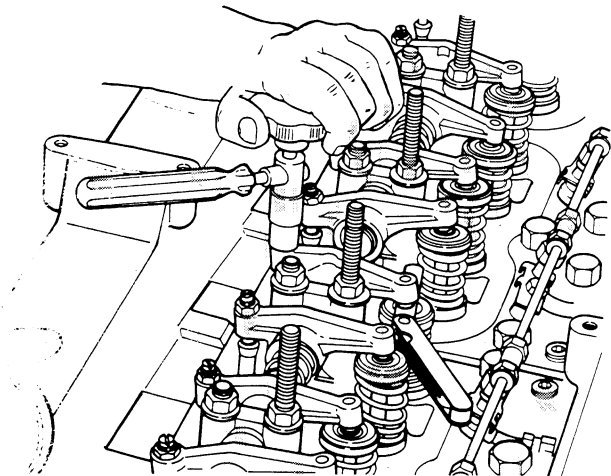

**ADJUST VALVE TAPPETS. REFER TO STEP 26  
FOR COLD SETTING OR TO STEP 33 FOR HOT  
SETTING.**

**STEP 18**

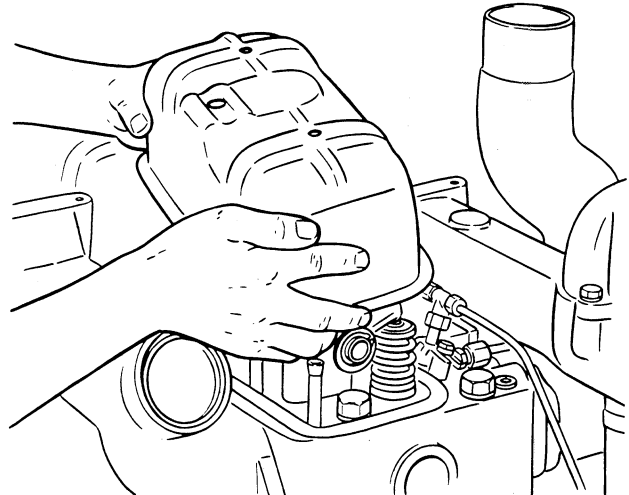

**INSTALL VALVE COVERS AND GASKETS.**

---

**STEP 19**

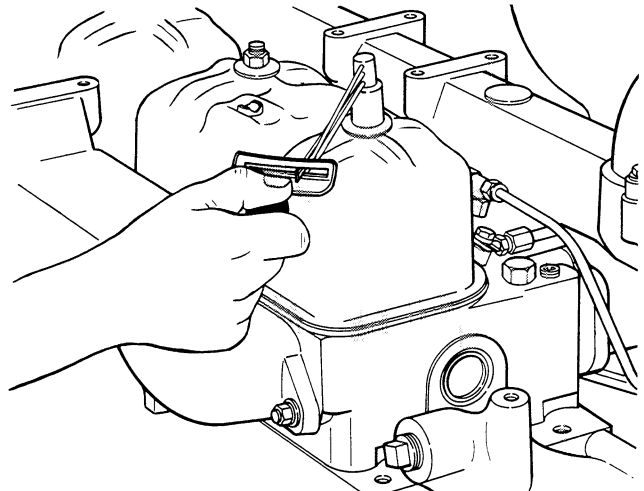

**TORQUE VALVE COVER NUTS 60 TO 70 IN. LBS.**

---

**STEP 20**

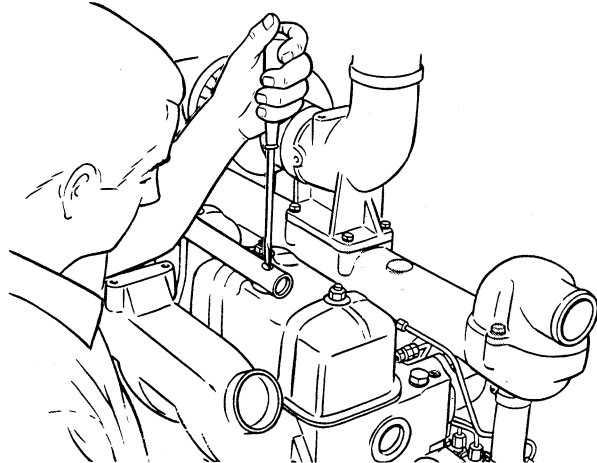

**INSTALL BREATHER TUBE AND GASKETS.**

# Adjusting Tappets

## Cold Setting

### STEP 21

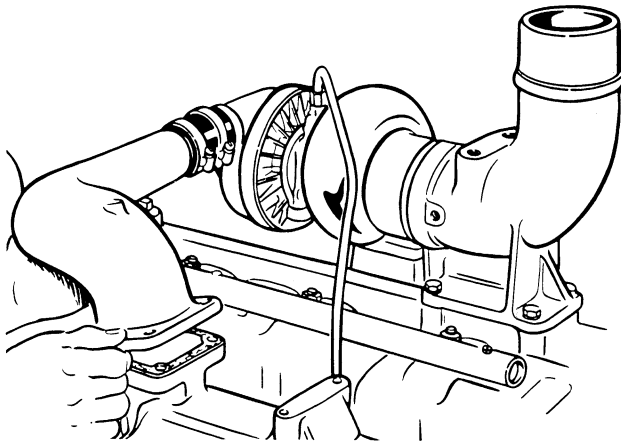

REMOVE TURBOCHARGER INTAKE ELBOW (IF SO EQUIPPED).

### STEP 22

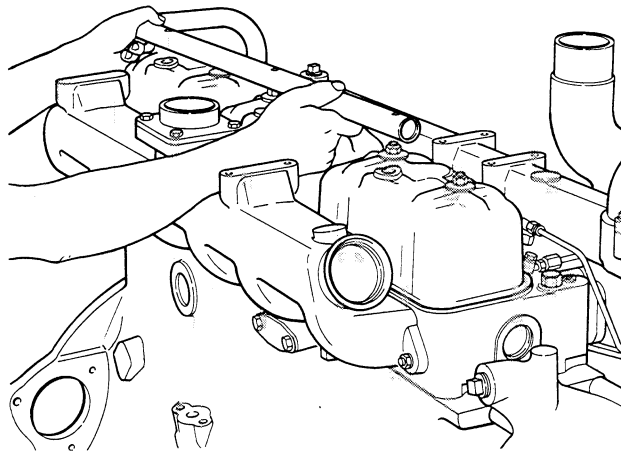

REMOVE BREATHER TUBE.

### STEP 23

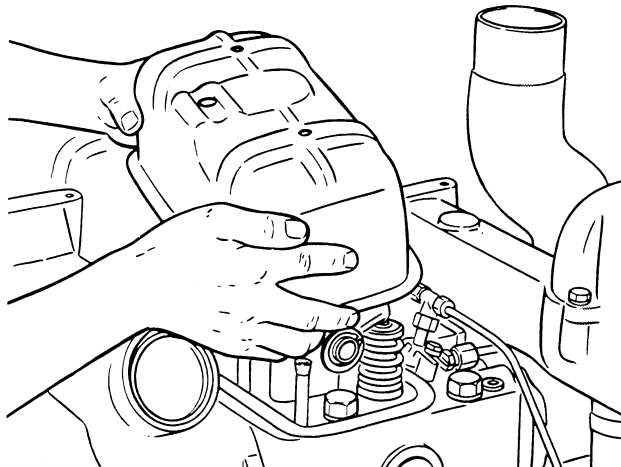

REMOVE VALVE COVERS AND GASKETS FROM ALL CYLINDERS.

### STEP 24

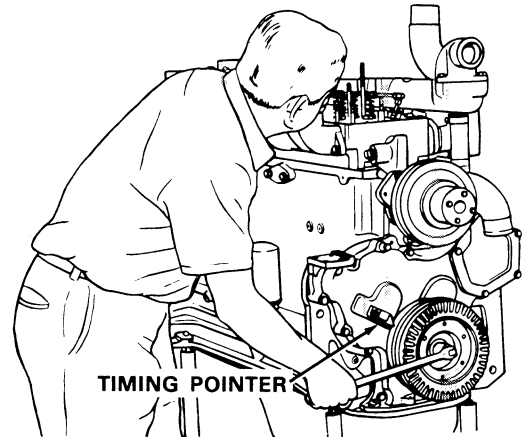

TIMING POINTER

CRANK ENGINE UNTIL TIMING POINTER IS ALIGNED WITH TDC TIMING MARK ON CRANKSHAFT PULLEY.

### STEP 25

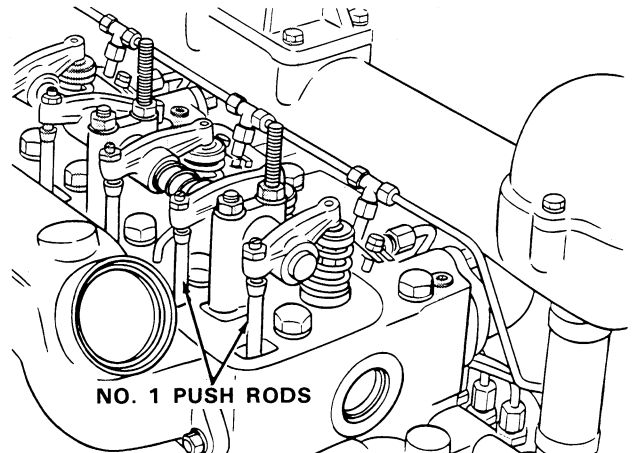

NO. 1 PUSH RODS

CHECK PUSH RODS ON NO. 1 CYLINDER FOR LOOSENESS. IF PUSH RODS ARE LOOSE, NO. 1 CYLINDER IS AT TDC ON THE COMPRESSION STROKE. IF PUSH RODS ARE TIGHT, CRANK ENGINE ONE COMPLETE REVOLUTION AND ALIGN TIMING POINTER WITH TDC MARK ON PULLEY.

**STEP 26**

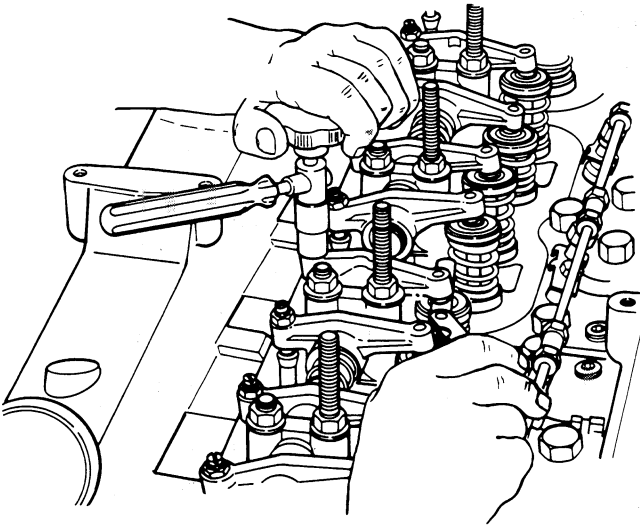

**CHECK AND ADJUST THE INTAKE AND EXHAUST VALVES AS POINTED OUT BY THE ARROWS BELOW.**

**TAPPET CLEARANCE COLD - INTAKE VALVES .015"  
EXHAUST VALVES - .025"**

**FOUR CYLINDER ENGINES**

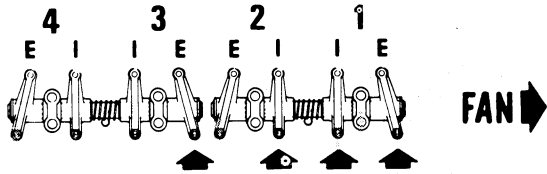

**NO. 1 TDC COMPRESSION STROKE**

**SIX CYLINDER ENGINES**

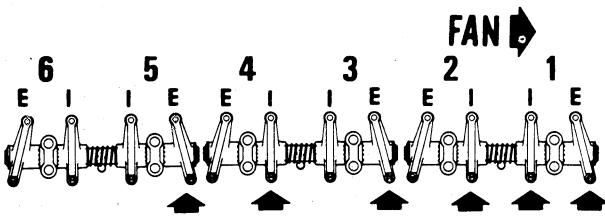

**NO. 1 TDC COMPRESSION STROKE**

**STEP 27**

**CRANK THE ENGINE ONE COMPLETE REVOLUTION AND ALIGN THE TIMING POINTER WITH THE TDC MARK ON CRANKSHAFT PULLEY.**

**CHECK AND ADJUST THE INTAKE AND EXHAUST VALVES AS POINTED OUT BY THE ARROWS BELOW.**

**TAPPET CLEARANCE COLD - INTAKE VALVES .015"  
EXHAUST VALVES .025"**

**FOUR CYLINDER ENGINES**

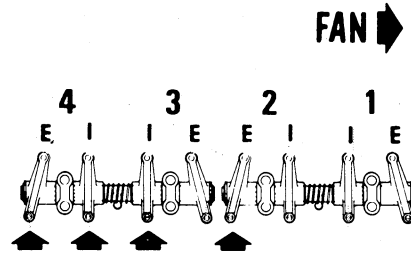

**NO. 4 TDC COMPRESSION STROKE**

**SIX CYLINDER ENGINES**

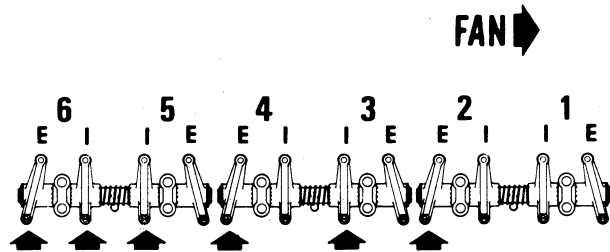

**NO. 6 TDC COMPRESSION STROKE**

**NOTE: AFTER COMPLETING COLD SETTING VALVE TAPPET ADJUSTMENT PROCEED TO STEP 35.**

# Adjusting Tappets

## Hot Setting with Engine Stopped

### STEP 28

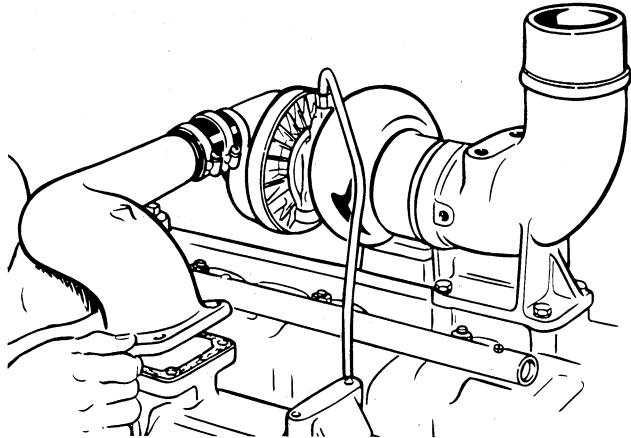

REMOVE TURBOCHARGER INTAKE ELBOW (IF SO EQUIPPED).

### STEP 29

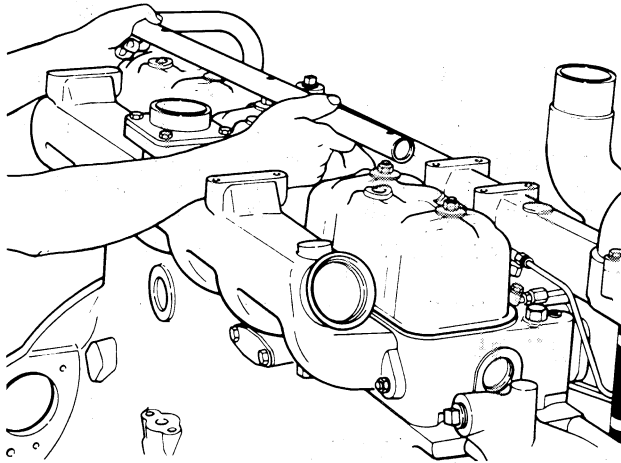

REMOVE BREATHER TUBE

### STEP 30

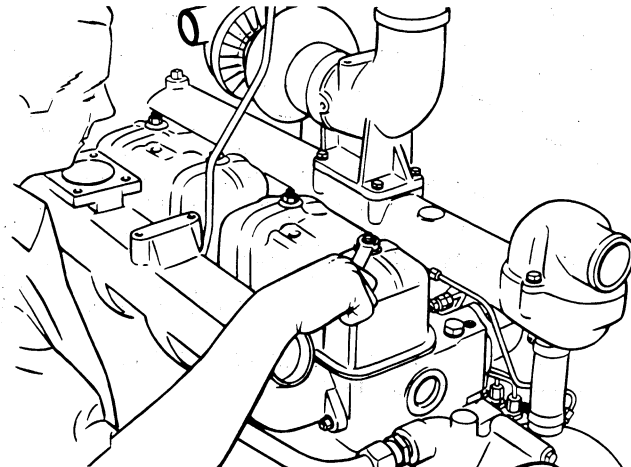

REMOVE VALVE COVERS AND GASKETS FROM ALL CYLINDERS.

### STEP 31

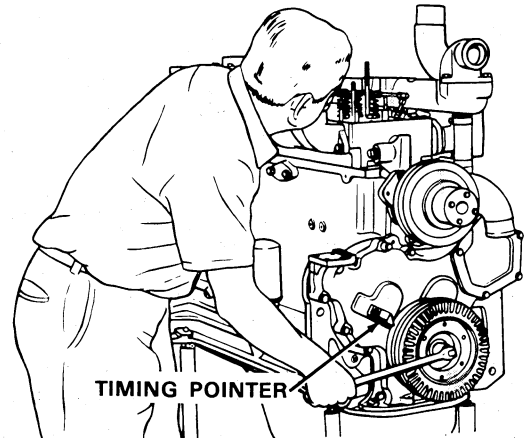

TIMING POINTER

CRANK ENGINE UNTIL TIMING POINTER IS ALIGNED WITH TDC TIMING MARK ON CRANKSHAFT PULLEY.

### STEP 32

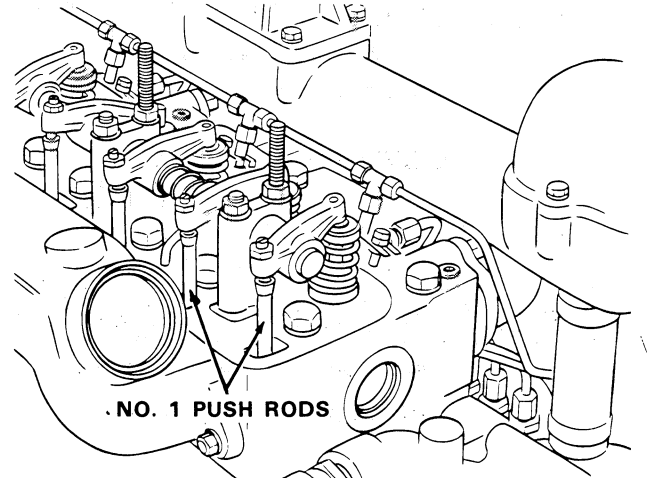

NO. 1 PUSH RODS

CHECK PUSH RODS ON NO. 1 CYLINDER FOR LOOSENESS. IF PUSH RODS ARE LOOSE, NO. 1 CYLINDER IS AT TDC ON THE COMPRESSION STROKE. IF PUSH RODS ARE TIGHT, CRANK ENGINE ONE COMPLETE REVOLUTION AND ALIGN TIMING POINTER WITH TDC MARK ON PULLEY.

**STEP 33**

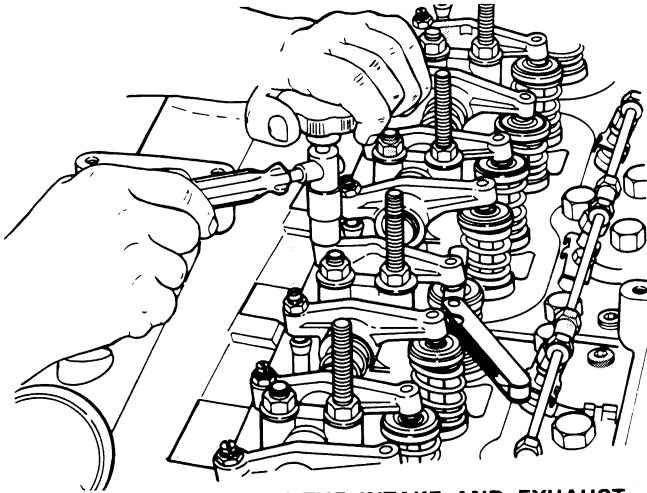

CHECK AND ADJUST THE INTAKE AND EXHAUST VALVES AS POINTED OUT BY THE ARROWS BELOW.  
TAPPET CLEARANCE HOT - INTAKE VALVES .015"  
EXHAUST VALVES .020"

**FOUR CYLINDER ENGINES**

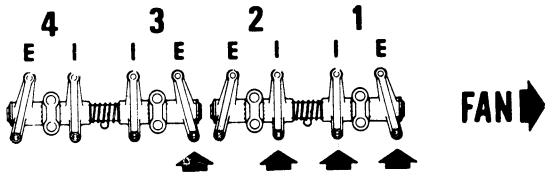

NO. 1 TDC COMPRESSION STROKE

**SIX CYLINDER ENGINES**

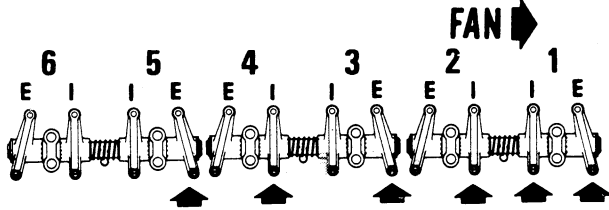

NO. 1 TDC COMPRESSION STROKE

**STEP 34**

CRANK THE ENGINE ONE COMPLETE REVOLUTION AND ALIGN THE TIMING POINTER WITH THE TDC MARK ON CRANKSHAFT PULLEY.

CHECK AND ADJUST THE INTAKE AND EXHAUST VALVES AS POINTED OUT BY THE ARROWS BELOW.

TAPPET CLEARANCE HOT - INTAKE VALVES .015"  
EXHAUST VALVES .020"

**FOUR CYLINDER ENGINES**

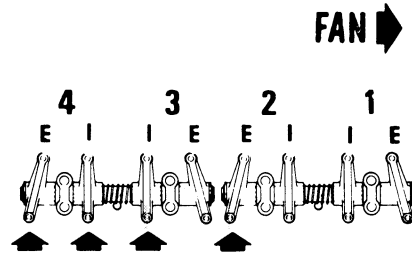

NO. 4 TDC COMPRESSION STROKE

**SIX CYLINDER ENGINES**

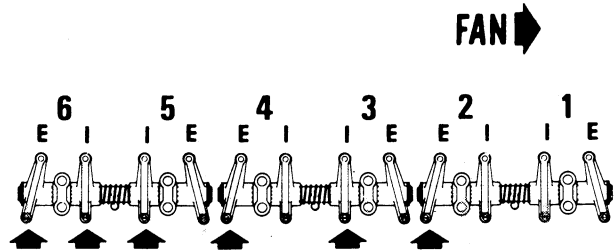

NO. 6 TDC COMPRESSION STROKE

**STEP 35**

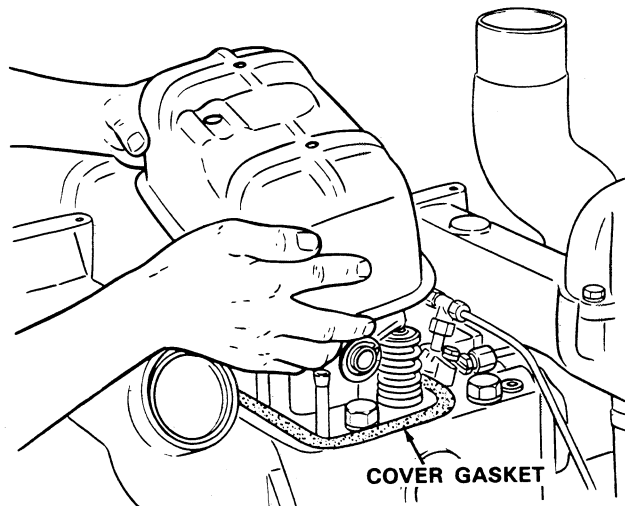

COVER GASKET

AFTER TAPPET ADJUSTMENT, INSTALL VALVE COVERS AND GASKETS.

**STEP 36**

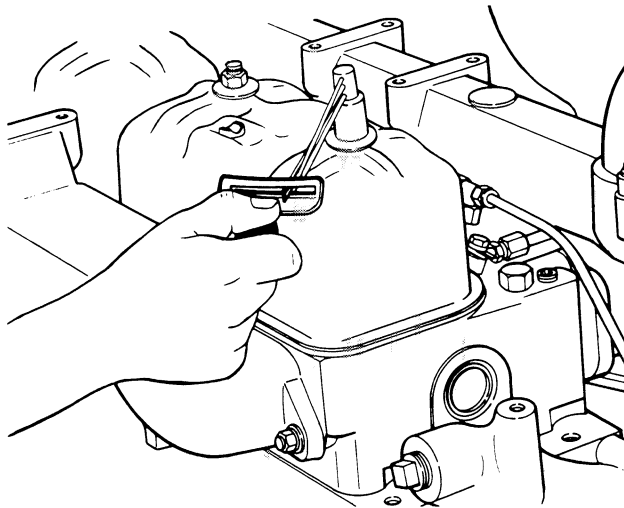

**TORQUE VALVE COVER NUTS 60 TO 70 IN. LBS.**

**STEP 37**

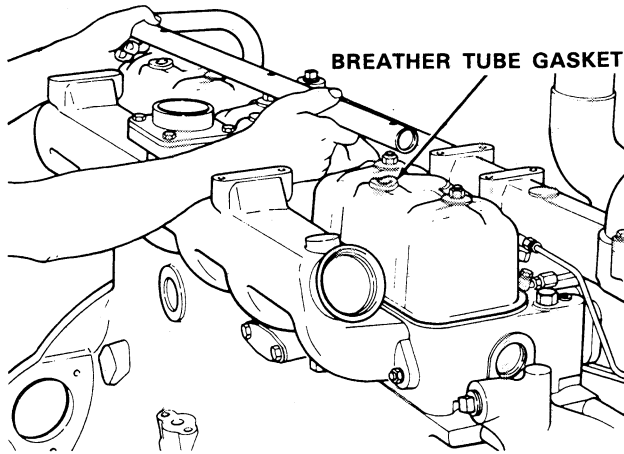

**BREATHER TUBE GASKET**

**INSTALL BREATHER TUBE AND GASKETS.**

**STEP 38**

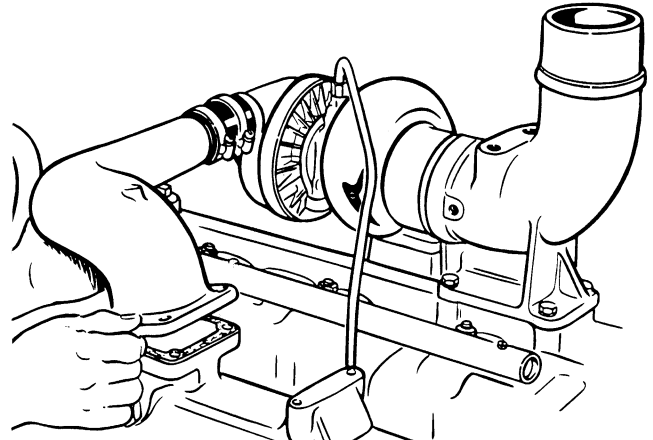

**INSTALL TURBOCHARGER INTAKE ELBOW**

# Checking Nozzle Spray Pattern and Engine Compression

## Nozzle Removal

### STEP 39 (CLAMP TYPE INJECTOR)

NOZZLE PULLER A43278

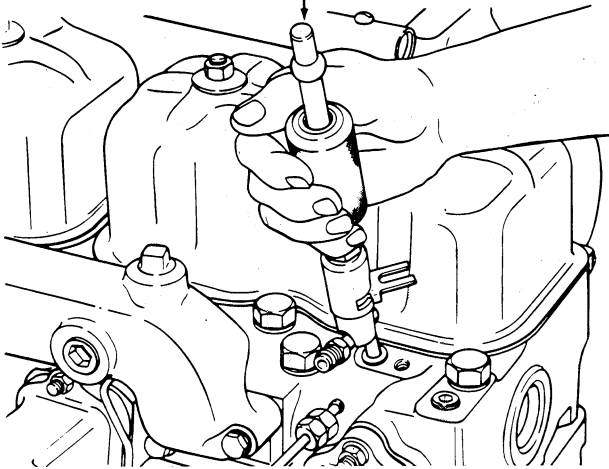

REMOVE AND TEST EACH FUEL INJECTOR. REFER TO SECTION 3013. PERFORM A COMPRESSION TEST ON EACH CYLINDER BEFORE INSTALLING FUEL INJECTOR

### STEP 40 (SCREW-IN TYPE INJECTOR)

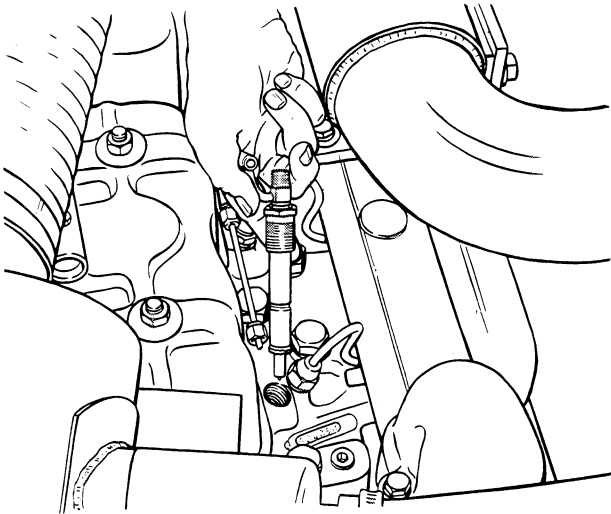

REMOVE AND TEST EACH FUEL INJECTOR. REFER TO SECTION 3113. PERFORM A COMPRESSION TEST ON EACH CYLINDER BEFORE INSTALLING FUEL INJECTOR.

## Compression Check

### STEP 41

THERE ARE TWO METHODS OF CHECKING COMPRESSION PRESSURE - THE CRANKING METHOD AND THE ENGINE RUNNING METHOD. THE ENGINE MUST BE AT OPERATING TEMPERATURE FOR EITHER METHOD USED.

A. CRANKING METHOD - REMOVE ALL INJECTORS.

B. RUNNING METHOD - DISCONNECT HIGH PRESSURE FUEL LINE AND LEAKOFF LINE FROM NO. 1 INJECTOR. ROUTE FUEL FROM THESE LINES BACK TO FUEL TANK OR CLEAN CONTAINER. REPEAT FOR EACH CYLINDER.

**CAUTION** Before cranking engine make sure all operating controls are in neutral, brakes are set and wheels are securely blocked.

### STEP 42 (CLAMP TYPE INJECTOR)

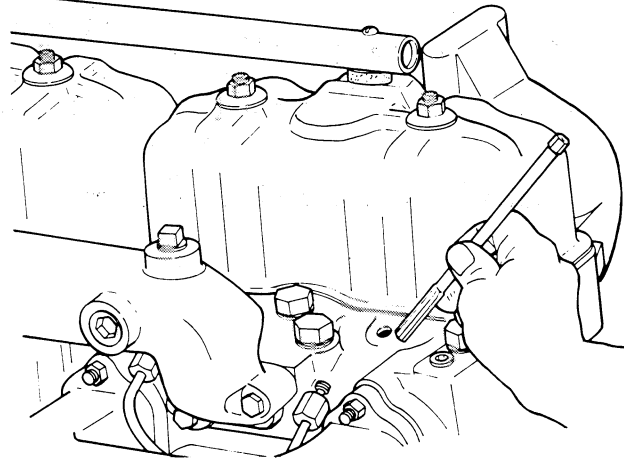

CLEAN CYLINDER HEAD INJECTOR BORE USING BORE CLEANING TOOL A43277.



**Suggest:**

**If the above button click is invalid.**

**Please download this document**

**first, and then click the above link**

**to download the complete manual.**

**Thank you so much for reading**

**STEP 43 (CLAMP TYPE INJECTOR)**

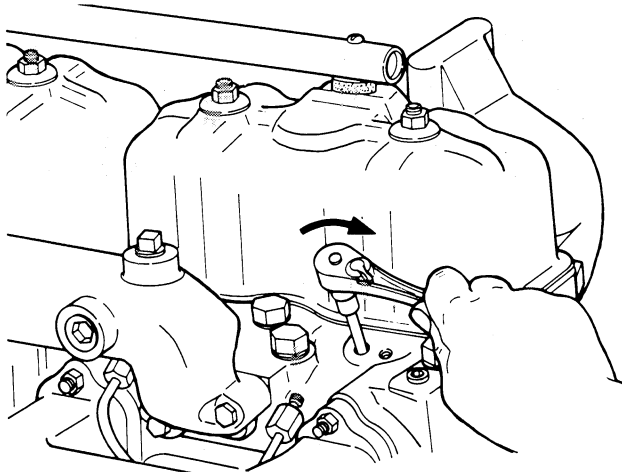

ALWAYS TURN TOOL CLOCKWISE. COUNTER-CLOCKWISE ROTATION DULLS TOOL. BLOW OUT WITH COMPRESSED AIR.

**STEP 44 (SCREW-IN TYPE INJECTOR)**



BORE CLEANING TOOL  
 NUDAY CO. P/N 6062  
 14615 WYOMING AVE.  
 DETROIT, MICHIGAN 48238  
 (PART OF KIT 2205)

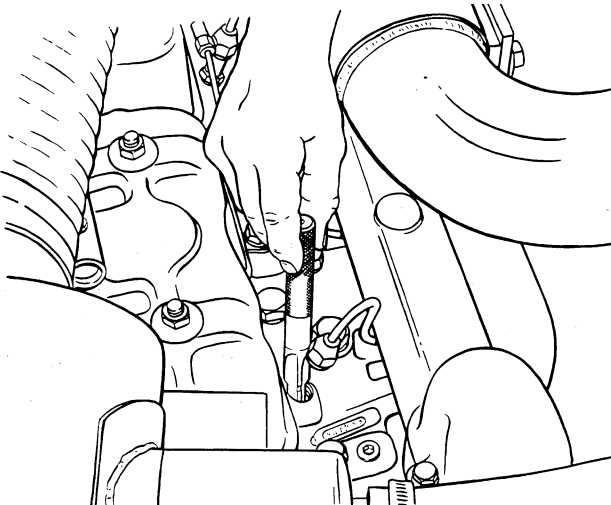

CLEAN CYLINDER HEAD INJECTOR BORE USING BORE CLEANING TOOL 6062.

**STEP 45 (CLAMP TYPE INJECTOR)**

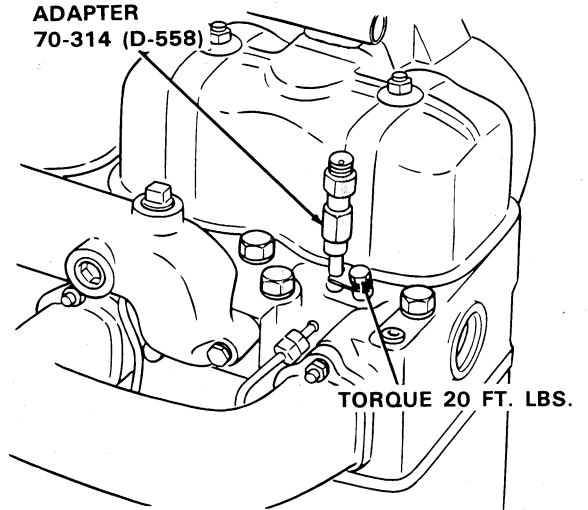
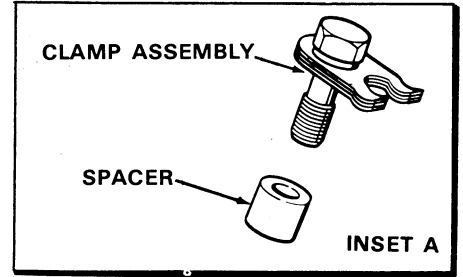

INSTALL BACHARACH 70-314 (D-558) COMPRESSION GAUGE ADAPTER. SECURE WITH AN ORIGINAL INJECTOR CLAMP ASSEMBLY AND SPACER.

**STEP 46 (CLAMP TYPE INJECTOR)**

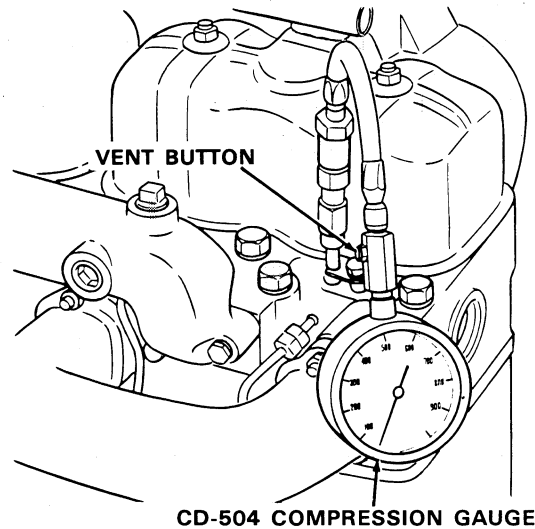

CONNECT CASE NO. CD-504 COMPRESSION GAUGE TO ADAPTER.  
 NOTE: TAKE SEVERAL COMPRESSION READINGS ON EACH CYLINDER USING VENT VALVE BUTTON TO RELIEVE GAUGE PRESSURE.  
 SEE CHART ON NEXT PAGE.

**<https://www.ebooklibonline.com>**

Hello dear friend!

Thank you very much for reading.

Enter the link into your browser.

The full manual is available for immediate download.

**<https://www.ebooklibonline.com>**