

1. Trim along dashed line.
2. Slide into pocket on Binder Spine.

TYPE 1-4

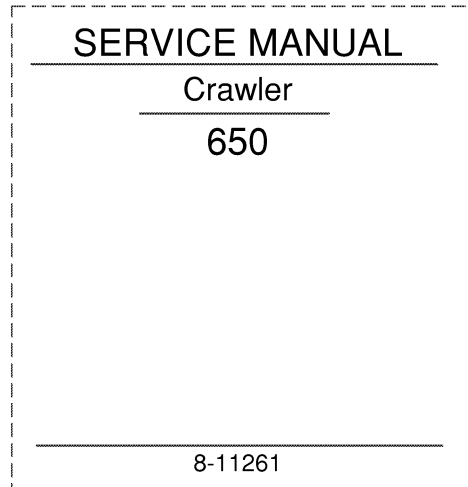

1. Trim along dashed line.
2. Slide into pocket on Binder Spine.

TYPE 1-4

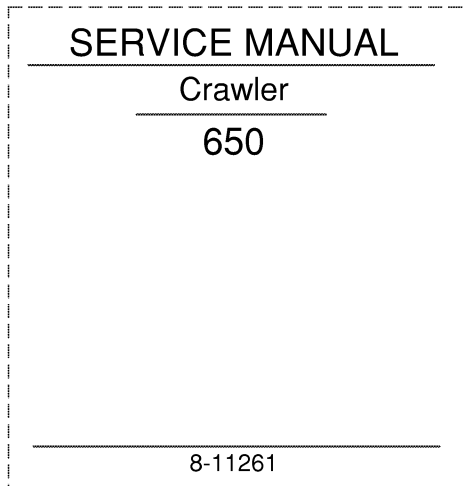

1. Trim along dashed line.
2. Slide into pocket on Binder Spine.

TYPE 1-4

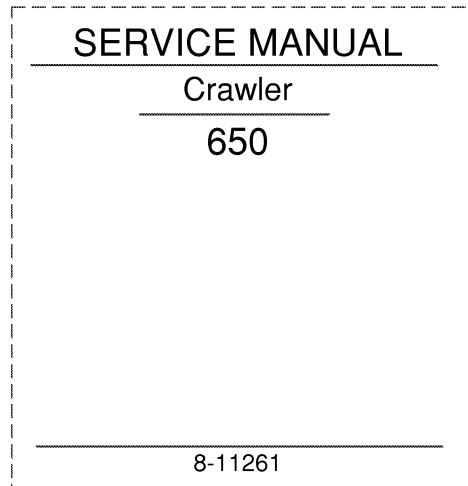

1. Trim along dashed line.
2. Slide into pocket on Binder Spine.

TYPE 1-4

650 Crawler
Service Manual

Table of Contents

Description	Section No	Form No.
General	Tab 1	
Section Index - General		8-14420
Standard Torque Specifications... ..	1001	8-71600
Fluids and Lubricants	1002	8-14430
Engine	Tab 2	
Section Index - Engine		8-14440
Engine Stall Tests	2000	8-14450
Engine Removal and Installation and Radiator		
Removal and Installation	2001	8-14460
Specification Details.....	2402	8-24163
Cylinder Head and Valve Train	2415	8-24173
Cylinder Block	2425	8-24183
Lubrication System	2445	8-24193
Cooling System	2455	8-24203
Turbocharger	2465	8-25550
Turbocharger Failure Analysis	2565	9-78235
Fuel System	Tab 3	
Section Index - Fuel System		8-14470
Fuel System and Filters .. .	3410	8-24212
Fuel Injection Pump and Drive Gear	3415	7-37141
Fuel Injectors	3413	8-24233
Electrical	Tab 4	
Section Index - Electrical		8-14480
Removal and Installation of Electrical Components.....	4001	8-14490
Electrical Specifications, Troubleshooting and Schematic	4002	8-14800
Batteries .. .	4003	8-11360
Instrument Panel and Gauges	4004	8-14510
Starter and Starter Solenoid	4006	8-72280
Alternator	4019	8-12901
Track	Tab 5	
Section Index - Track		8-14520
Inspection of Track System Components	5501	8-14950
Case Lubricated Track	5504	8-14530
Sealed Track and Track Frame	5506	8-14540
Idler, Track Adjuster and Recoil Housing	5508	8-14550
Sprocket	5509	8-14560
Carrier Roller	5510	8-14570
Track Roller	5511	8-14580

Reprinted

650 Crawler
Service Manual
Table of Contents

Description	Section No.	Form No.
Power Train	Tab 6	
Section Index - Power Train		8-14590
Specifications, Schematic and Troubleshooting	6002	8-14600
Torque Converter and Torque Converter Housing	6006	8-14610
Transmissin Control Valve	6007	8-13811
Modulator Valve	6008	8-14620
Transmission	6016	8-14630
Final Drive	6017	8-14640
 Brakes	 Tab 7	
Section Index - Brakes		8-14650
Removal and Installation of Master Cylinder, and Removing Air from the Brake System	7001	8-14660
Master Cylinder	7002	8-14670
Brakes	7003	8-14680
 Hydraulics	 Tab 8	
Section Index - Hydraulics		8-14690
Removal and Installation of Hydraulic Components	8001	8-14920
Specifications, Troubleshooting and Schematics	8002	8-14700
Cleaning the Hydraulic System.....	8003	8-14710
Equipment Pump	8005	8-14720
Equipment Control Valve	8007	8-14730
Cylinders	8008	8-14741
 Mounted Equipment	 Tab 9	
Section Index - Mounted Equipment		8-14750
Pedals and Levers	9001	8-14760
Blade	9002	8-14770
Ripper	9031	8-14780
ROPS Cab and Canopy	9061	8-14790
Suspension Seat	9065	8-14910

<https://www.ebooklibonline.com>

Hello dear friend!

Thank you very much for reading.

Enter the link into your browser.

The full manual is available for immediate download.

<https://www.ebooklibonline.com>

1001

STANDARD TORQUE SPECIFICATIONS

TABLE OF CONTENTS

Torque Specifications - Decimal Hardware	1001-2	Torque Specifications - Steel Hydraulic Fittings	1001-4
Torque Specifications - Metric Hardware ...	1001-3	Torque Specifications - O-ring Face Seal Fittings	1001-5

TORQUE SPECIFICATIONS - DECIMAL HARDWARE

Use the torques in this chart when special torques are not given. These torques apply to fasteners with both UNC and UNF threads as received from suppliers, dry, or when lubricated with engine oil. Not applicable if special graphites, molydisulfide greases, or other extreme pressure lubricants are used.

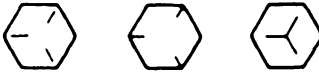
Grade 5 Bolts, Nuts, and Studs		
		
Size	Pound- Feet	Newton metres
1/4 in	9-11	12-15
5/16 in	17-21	23-28
3/8 in	35-42	48-57
7/16 in	54-64	73-87
1/2 in	80-96	109-130
9/16 in	110-132	149-179
5/8 in	150-180	203-244
3/4 in	270-324	366-439
7/8 in	400-480	542-651
1.0 in	580-696	787-944
1-1/8 in	800-880	1085-1193
1-1/4 in	1120-1240	1519-1681
1-3/8 in	1460-1680	1980-2278
1-1/2 in	1940-2200	2631-2983

Grade 8 Bolts, Nuts, and Studs		
		
Size	Pound- Feet	Newton metres
1/4 in	12-15	16-20
5/16 in	24-29	33-39
3/8 in	45-54	61-73
7/16 in	70-84	95-114
1/2 in	110-132	149-179
9/16 in	160-192	217-260
5/8 in	220-264	298-358
3/4 in	380-456	515-618
7/8 in	600-720	814-976
1.0 in	900-1080	1220-1465
1-1/8 in	1280-1440	1736-1953
1-1/4 in	1820-2000	2468-2712
1-3/8 in	2380-2720	3227-3688
1-1/2 in	3160-3560	4285-4827

NOTE: Use thick nuts with Grade 8 bolts.

TORQUE SPECIFICATIONS - METRIC HARDWARE

Use the following torques when special torques are not given.

These values apply to fasteners with coarse threads as received from supplier, plated or unplated, or when lubricated with engine oil. These values do not apply if graphite or molydisulfide grease or oil is used.

Grade 8.8 Bolts, Nuts, and Studs		
		
Size	Pound-Feet	Newton metres
M4	2-3	3-4
M5	5-6	6.5-8
M6	8-9	10.5-12
M8	19-23	26-31
M10	38-45	52-61
M12	66-79	90-107
M14	106-127	144-172
M16	160-200	217-271
M20	320-380	434-515
M24	500-600	675-815
M30	920-1100	1250-1500
M36	1600-1950	2175-2600

Grade 10.9 Bolts, Nuts, and Studs		
		
Size	Pound-Feet	Newton metres
M4	3-4	4-5
M5	7-8	9.5-11
M6	11-13	15-17.5
M8	27-32	37-43
M10	54-64	73-87
M12	93-112	125-15
M14	149-179	200-245
M16	230-280	310-380
M20	450-540	610-730
M24	780-940	1050-1275
M30	1470-1770	2000-2400
M36	2580-3090	3500-4200

Grade 12.9 Bolts, Nuts, and Studs



Usually the torque values specified for grade 10.9 fasteners can be used satisfactorily on grade 12.9 fasteners.

TORQUE SPECIFICATIONS - STEEL HYDRAULIC FITTINGS

Tube OD Hose ID	Thread Size	Pound- Feet	Newton metres
37 Degree Flare Fittings			
1/4 in 6.4 mm	7/16-20	6-12	8-16
5/16 in 7.9 mm	1/2-20	8-16	11-21
3/8 in 9.5 mm	9/16-18	10-25	14-33
1/2 in 12.7 mm	3/4-16	15-42	20-56
5/8 in 15.9 mm	7/8-14	25-58	34-78
3/4 in 19.0 mm	1-1/16-12	40-80	54-108
7/8 in 22.2 mm	1-3/16-12	60-100	81-135
1.0 in 25.4 mm	1-5/16-12	75-117	102-158
1-1/4 in 31.8 mm	1-5/8-12	125-165	169-223
1-1/2 in 38.1 mm	1-7/8-12	210-250	285-338

Tube OD Hose ID	Thread Size	Pound- Feet	Newton metres
Straight Threads with O-ring			
1/4 in 6.4 mm	7/16-20	12-19	16-25
5/16 in 7.9 mm	1/2-20	16-25	22-23
3/8 in 9.5 mm	9/16-18	25-40	34-54
1/2 in 12.7 mm	3/4-16	42-67	57-90
5/8 in 15.9 mm	7/8-14	58-92	79-124
3/4 in 19.0 mm	1-1/16-12	80-128	108-174
7/8 in 22.2 mm	1-3/16-12	100-160	136-216
1.0 in 25.4 mm	1-5/16-12	117-187	159-253
1-1/4 in 31.8 mm	1-5/8-12	165-264	224-357
1-1/2 in 38.1 mm	1-7/8-12	250-400	339-542

Split Flange Mounting Bolts		
Size	Pound- Feet	Newton metres
5/16-18	15-20	20-27
3/8-16	20-25	26-33
7/16-14	35-45	47-61
1/2-13	55-65	74-88
5/8-11	140-150	190-203

Section

2001

ENGINE REMOVAL AND INSTALLATION AND
RADIATOR REMOVAL AND INSTALLATION

RADIATOR REMOVAL

STEP 1

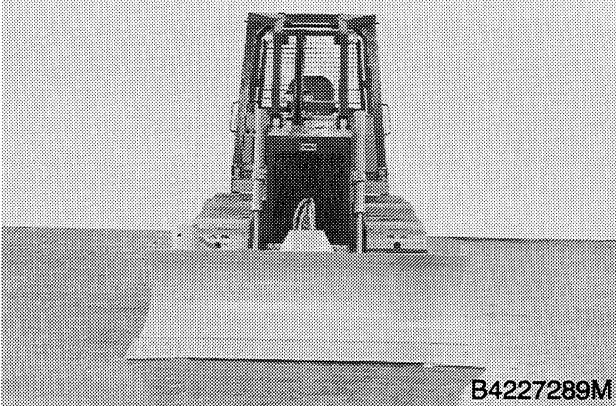

Park the machine on a level surface. Lower ALL hydraulically controlled attachments to the floor.

STEP 4

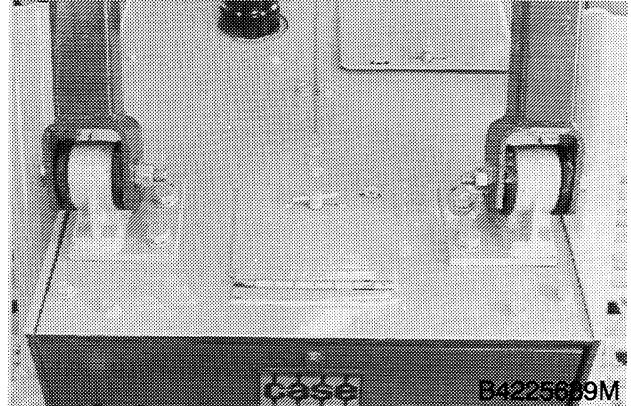

Close the access door.

STEP 2

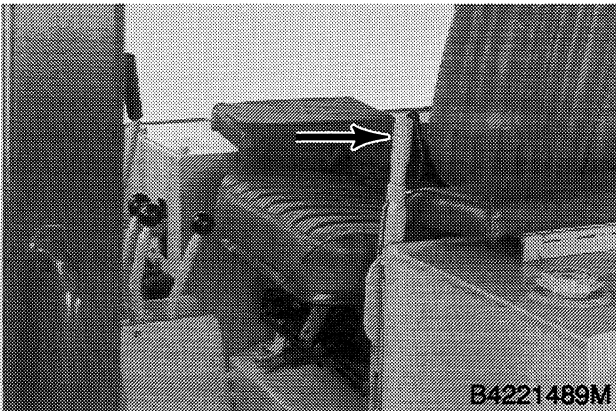

Apply the parking brake and stop the engine.

STEP 5

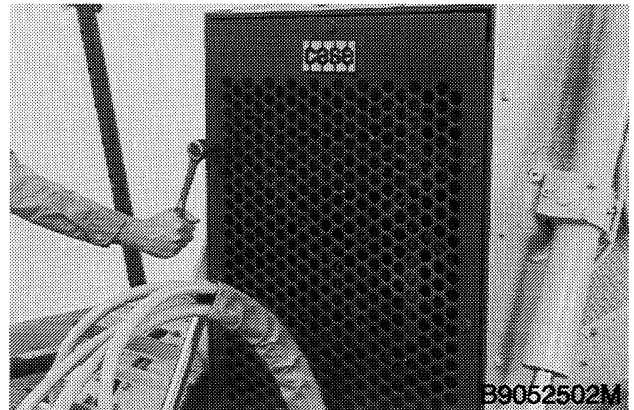

Loosen and remove the cap screws that hold the grille.

STEP 3

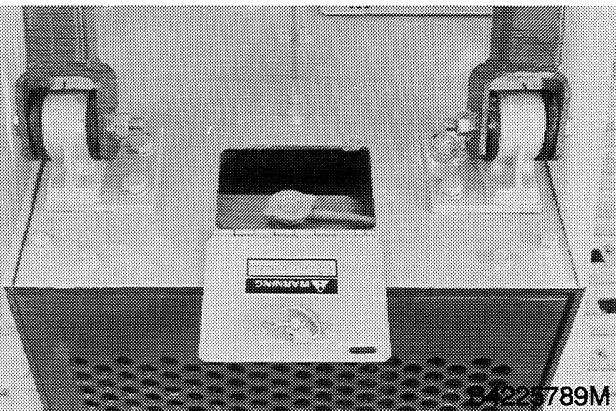

Open the access door and remove the radiator cap.

STEP 6

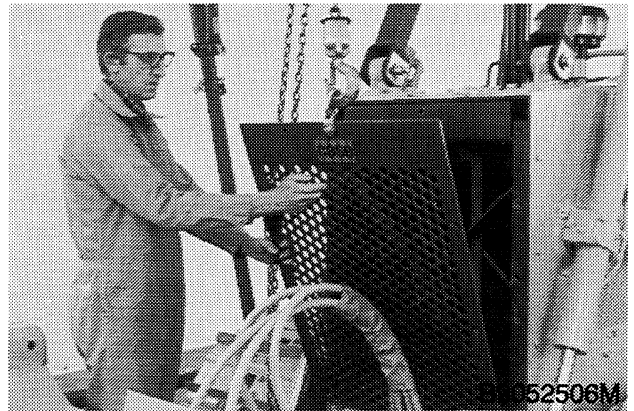

Tilt the grille forward and connect suitable lifting equipment to the grille. Remove the grille from the mounting bracket.

STEP 7

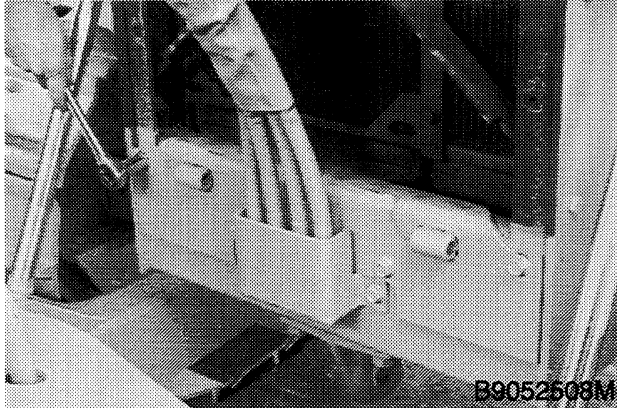

Loosen and remove the cap screws that hold the mounting bracket.

STEP 8

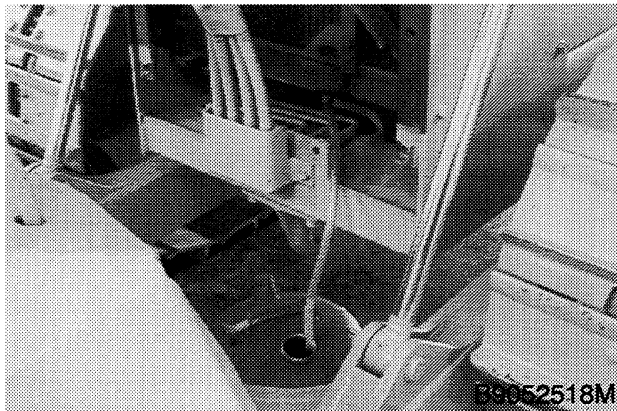

Install a hose on the drain valve. Open the drain valve and drain the cooling system. The cooling system holds 20 U.S. quarts (18.9 litres) of coolant.

STEP 9

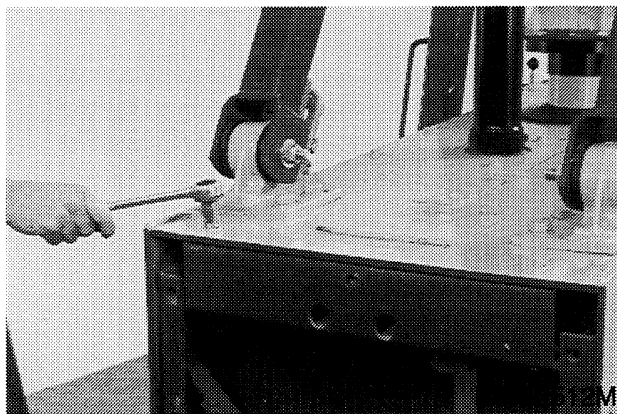

Loosen and remove the cap screws that fasten the baffle to the top of the radiator shroud. Remove the baffle.

STEP 10

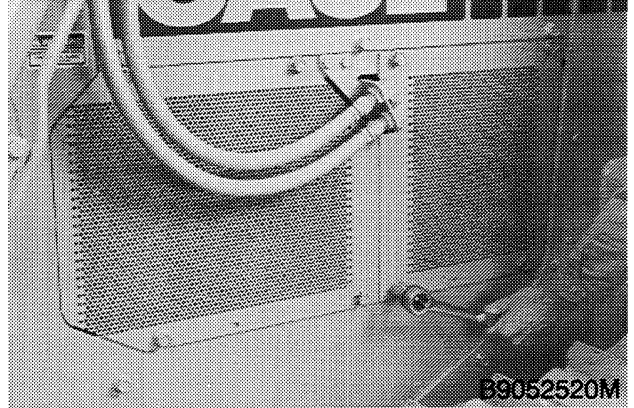

Loosen the bottom cap screws for the top side panel. Loosen and remove the top cap screws and remove the top side panel.

STEP 11

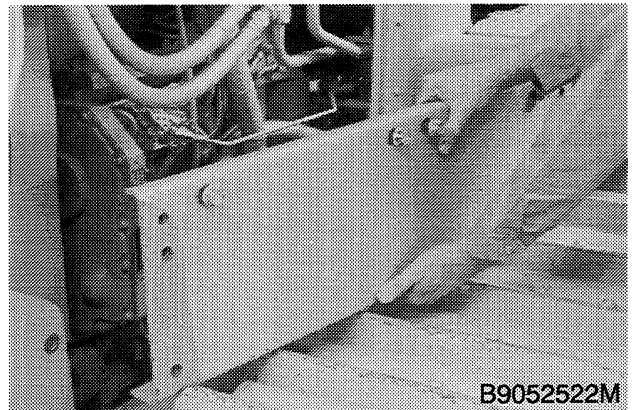

Loosen and remove the cap screws that hold the bottom side panel. Remove the bottom side panel.

STEP 12

Repeat steps 10 and 11 for the top side panel and the bottom side panel on the right side of the machine.

STEP 13



Remove the precleaner.

STEP 14

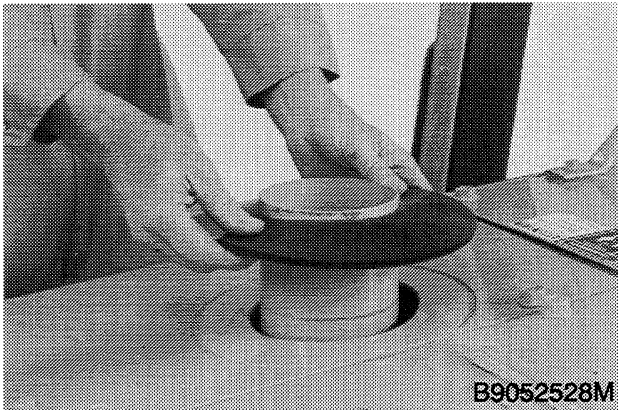

Remove the grommet.

STEP 15

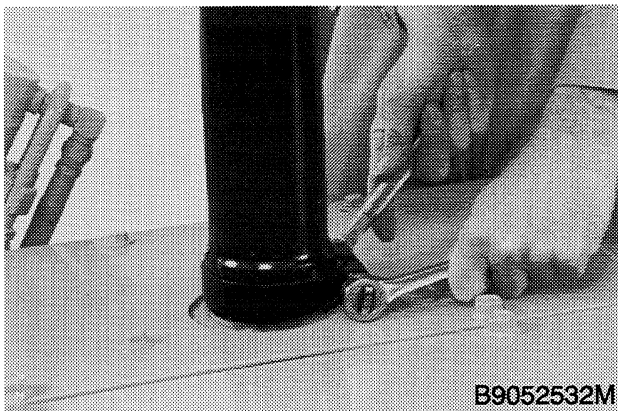

Loosen the clamp that fastens the extension pipe to the muffler. Remove the extension pipe.

STEP 16



Loosen and remove the cap screws that hold the left side of the hood.

STEP 17



Remove the left side of the hood.

STEP 18

Repeat steps 16 and 17 for the right side of the hood.

STEP 19

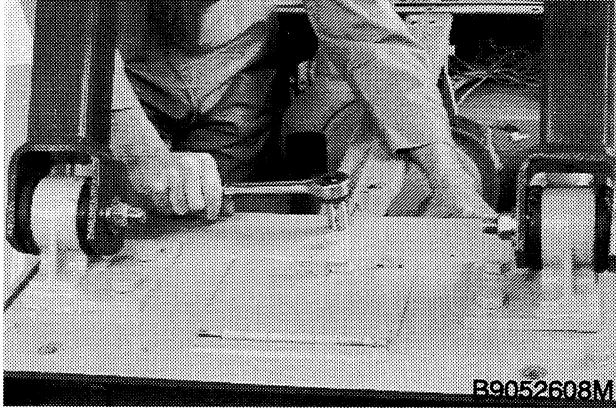

Loosen and remove the self-locking nuts, hardened washers, and bolts that fasten the center hood brace to the top plate.

STEP 20

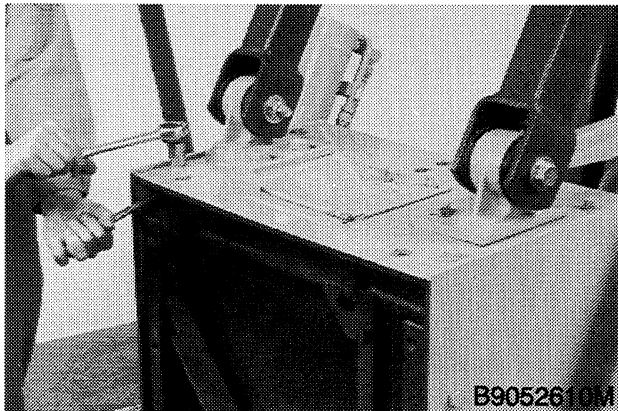

Loosen and remove the nuts and bolts that fasten the top plate to both sides of the radiator shroud. If the machine is not equipped with a brush guard, remove the top plate.

NOTE: If the machine is equipped with a brush guard, do steps 21, 22, and 23. If the machine is not equipped with a brush guard, go to step 24.

STEP 21

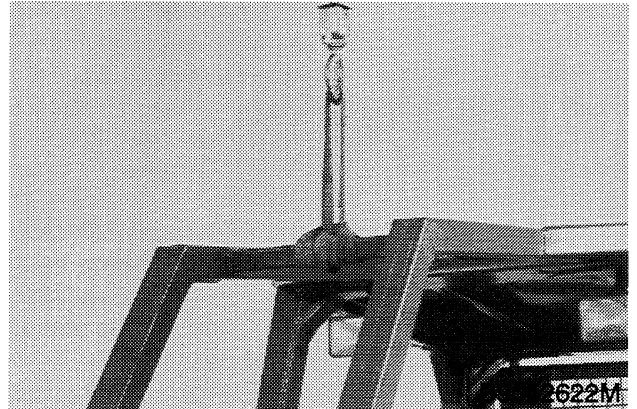

Connect suitable lifting equipment to the brush guard.

STEP 22

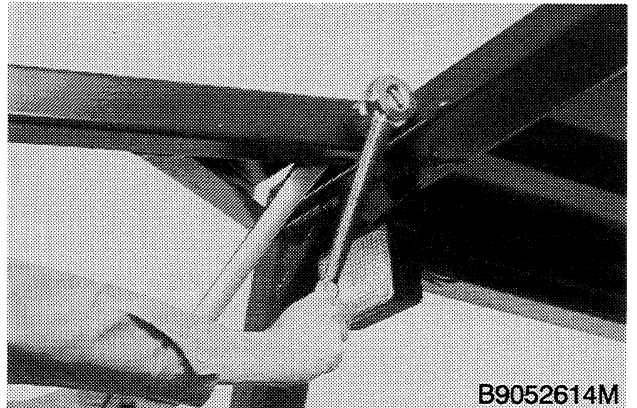

Loosen and remove the self-locking nuts and bolts that fasten the rear of the brush guard to the ROPS cab or ROPS canopy.

STEP 23

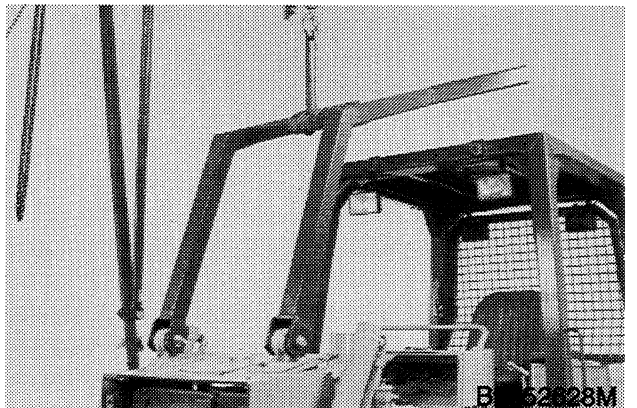

Remove the brush guard and top plate from the machine.

STEP 24

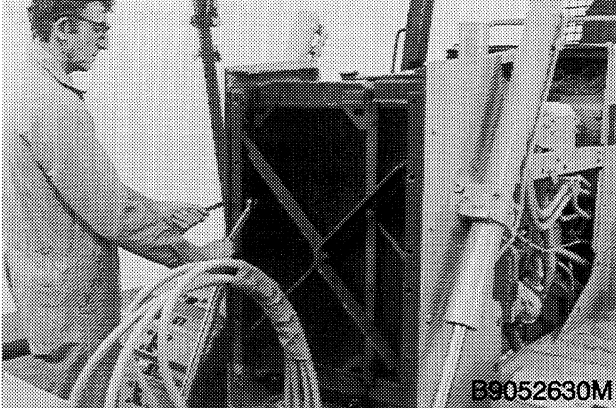

Loosen and remove the hardware that fastens both grille mounts and the cross brace to the radiator shroud. Remove the grille mounts and the cross brace.

STEP 27

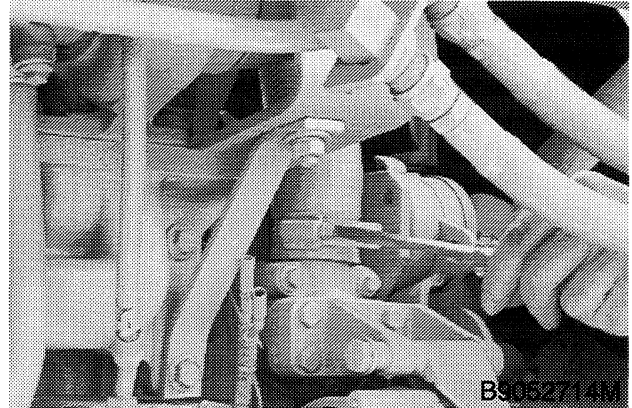

Loosen the clamp and disconnect the top radiator hose from the engine.

STEP 25

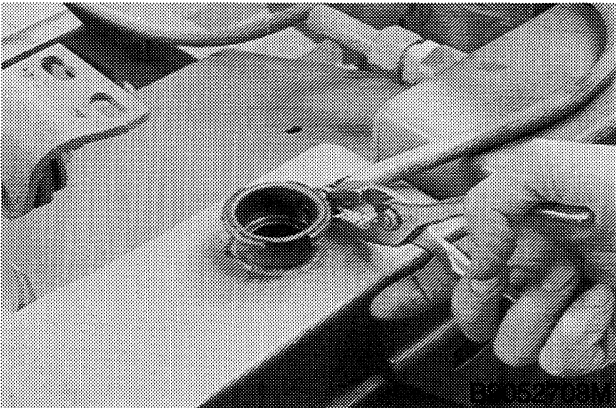

Disconnect the drain hose from the fill neck of the radiator.

STEP 28

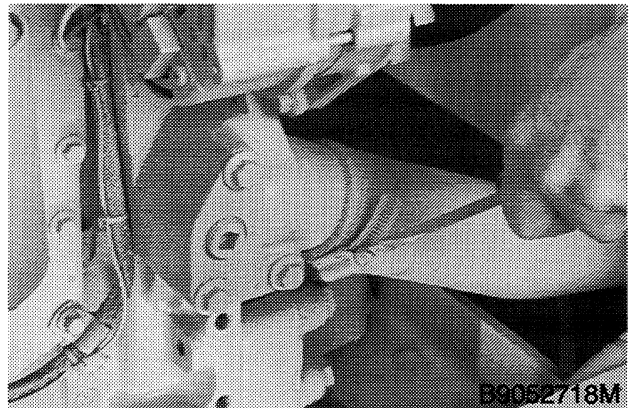

Loosen the clamp and disconnect the bottom radiator hose from the engine.

STEP 26

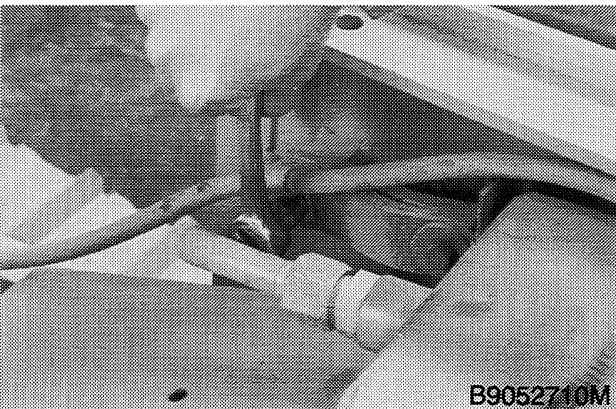

Loosen and remove the cap screws and flat washers that fasten the top radiator supports to the radiator shroud. A clamp for the drain hose is installed on the cap screw for the top radiator support on the left side of the radiator shroud.

STEP 29

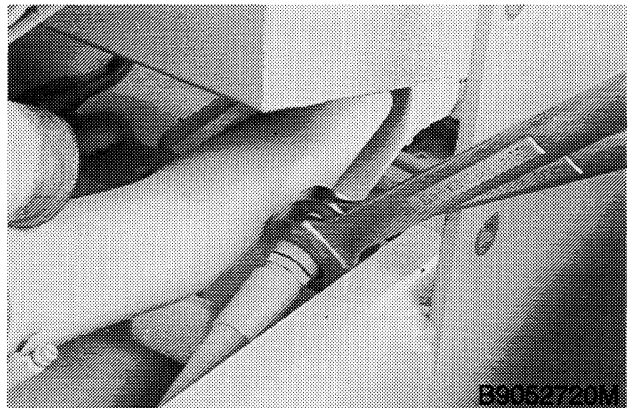

Disconnect the hose from the tube for the oil cooler.

STEP 30

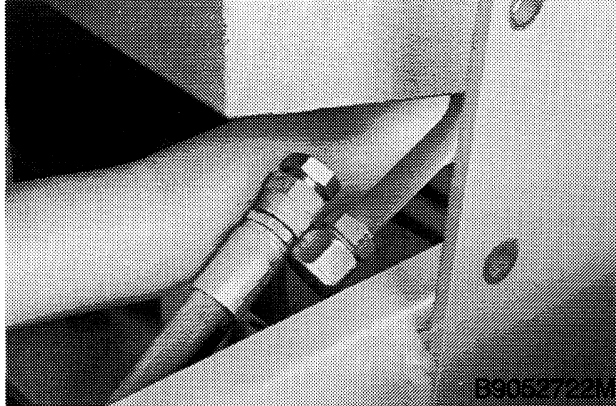

Install a plug in the hose and a cap on the tube.

STEP 31

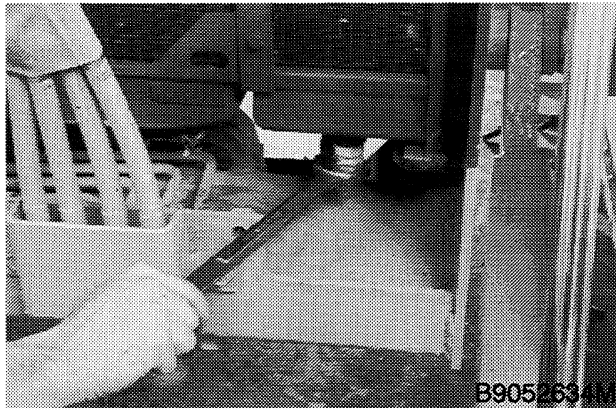

Disconnect the hose from the fitting in the bottom of the oil cooler.

STEP 32



Install a plug in the hose and a cap on the fitting.

STEP 33



Loosen and remove the cap screws and hardened washers that fasten the radiator to the mounting brackets.

STEP 34

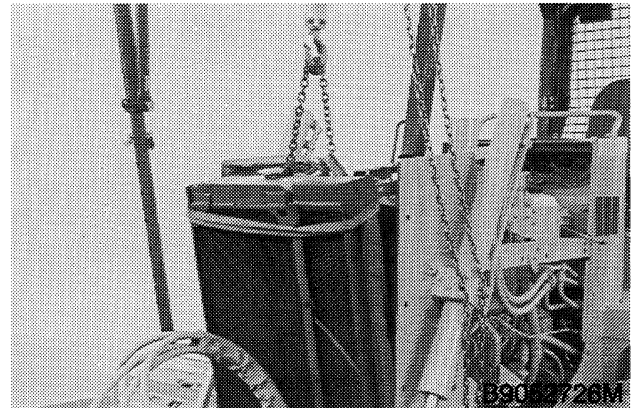

Tilt the radiator forward and connect suitable lifting equipment to the radiator.

STEP 35

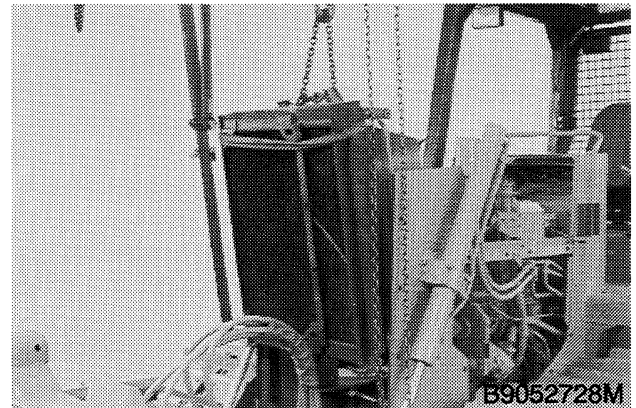

Remove the radiator and fan shroud from the machine.

STEP 36

Check the condition of the insulators in the mounting brackets for the radiator. If the insulators are damaged, install new insulators.

Disassembly of the Radiator

1. Loosen and remove the self-locking nuts, flat washers, and bolts that fasten the top radiator supports (1) to each side of the radiator (2).
2. Loosen and remove the self-locking nut, flat washer, clamp (3), spacer, and bolt that fasten the top hose (4) to the radiator shroud (5).
3. Loosen the hose clamp and disconnect the top hose (4) from the radiator (2).
4. Loosen and remove the nuts and bolts that fasten the clamps for the tube (6) to the radiator shroud (5).
5. Disconnect the tube (6) from the radiator (2).
6. Loosen the hose clamp and disconnect the bottom hose (7) from the radiator (2).
7. Loosen and remove the cap screws, lock washers, and flat washers that fasten the radiator shroud (5) to the radiator (2) and remove the radiator shroud (5).

Assembly of the Radiator

1. Install the radiator shroud (5). Install the cap screws, lock washers, and flat washers that fasten the radiator shroud (5) to the radiator (2) and tighten the cap screws.
2. Connect the bottom hose (7) to the radiator (2) and tighten the hose clamp.
3. Connect the tube (6) to the radiator (2).
4. Install the nuts and bolts that fasten the clamps for the tube (6) to the radiator shroud (5). Tighten the nuts.
5. Connect the top hose (4) to the radiator (2) and tighten the hose clamp.
6. Install the bolt, spacer, clamp (3), flat washer, and self-locking nut that fasten the top hose (4) to the radiator (2).
7. Install the bolts, flat washers, and self-locking nuts that fasten the radiator supports (1) to each side of the radiator (2). The bolts must be installed in the forward set of mounting holes on each side of the radiator (2). Tighten the self-locking nuts.

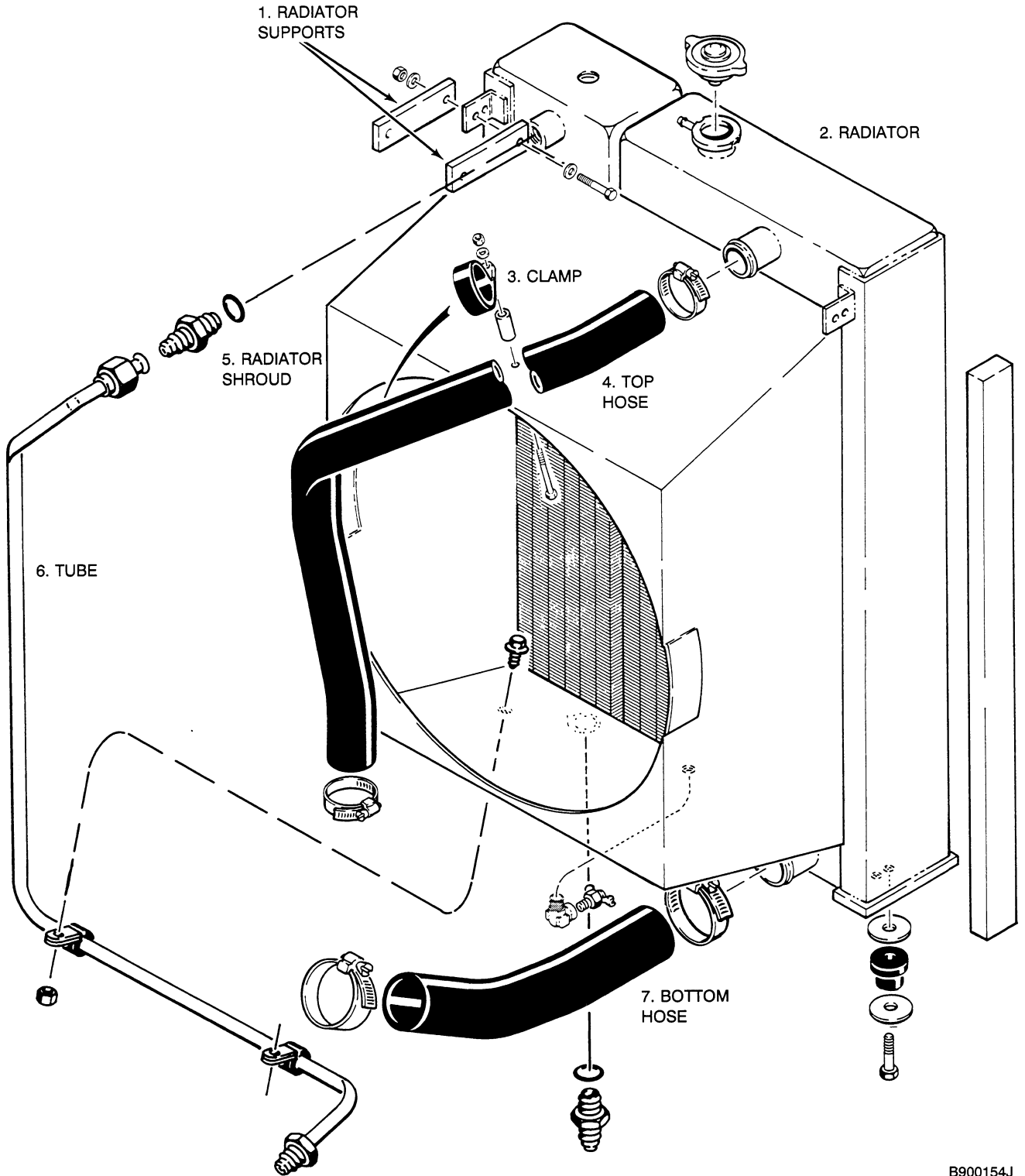

B900154J

RADIATOR INSTALLATION

STEP 37

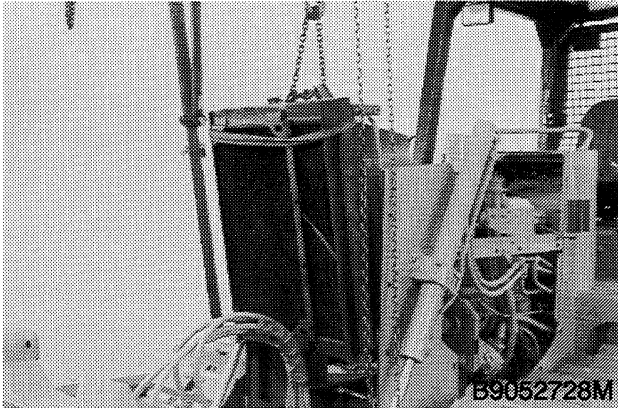

Install the radiator and fan shroud in position.

STEP 40

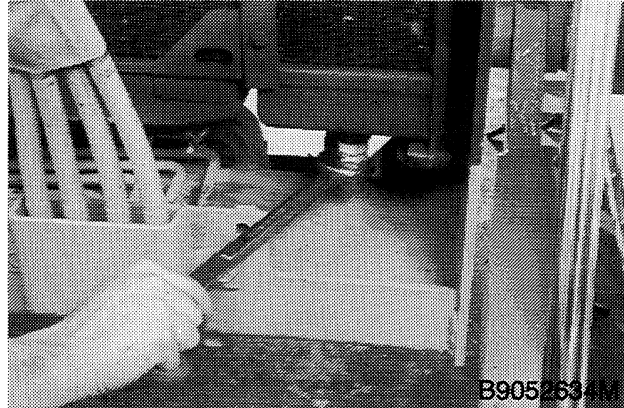

Remove the plug from the hose and the cap from the fitting in the bottom of the oil cooler. Connect the hose to the fitting.

STEP 38

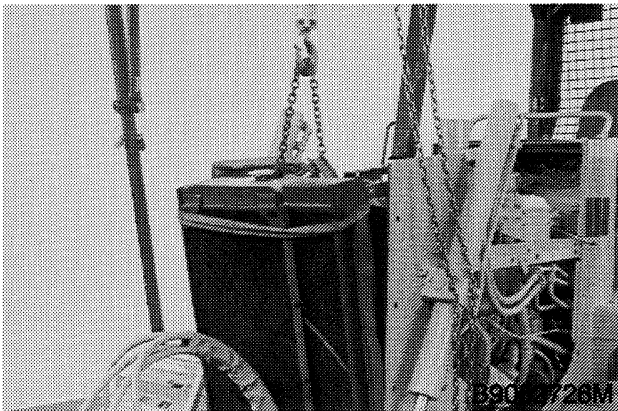

Lower the radiator onto the mounting brackets. Disconnect the lifting equipment from the radiator and push the radiator toward the engine.

STEP 41

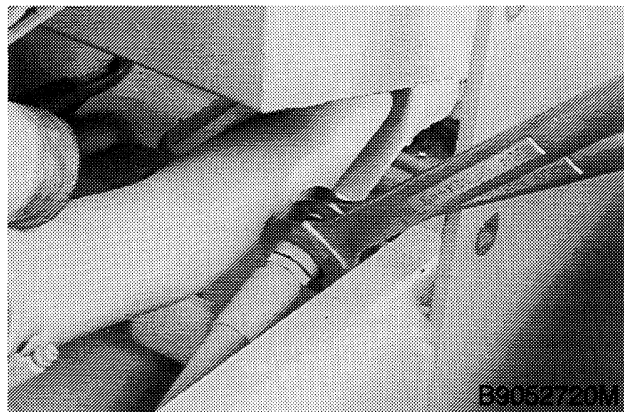

Remove the plug from the hose and the cap from the tube for the oil cooler. Connect the hose to the tube.

STEP 39

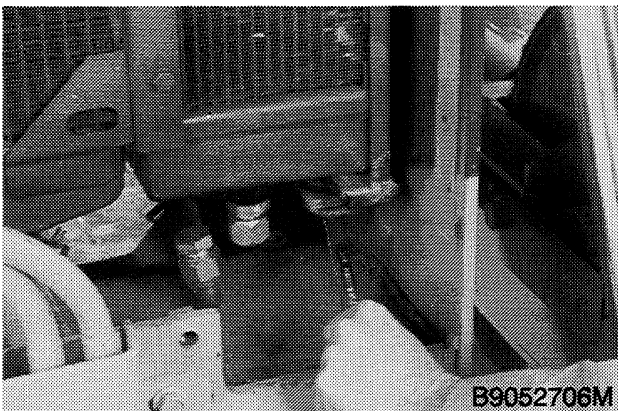

Install the cap screws and hardened washers that fasten the radiator to the mounting brackets. The cap screws must be installed in the forward set of mounting holes in the bottom of the radiator. Tighten the cap screws to 50 to 60 pound-feet (68 to 82 Nm).

STEP 42

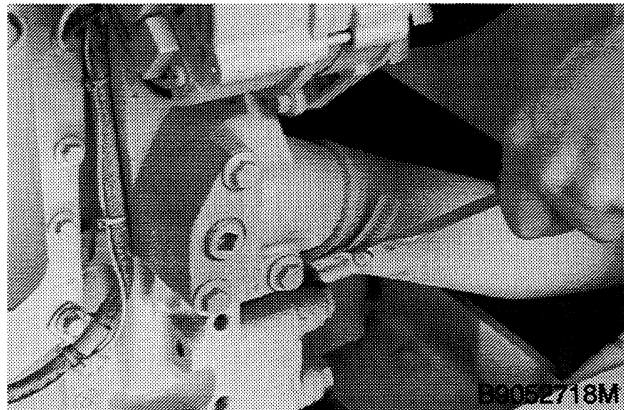

Connect the bottom radiator hose to the engine.

STEP 43

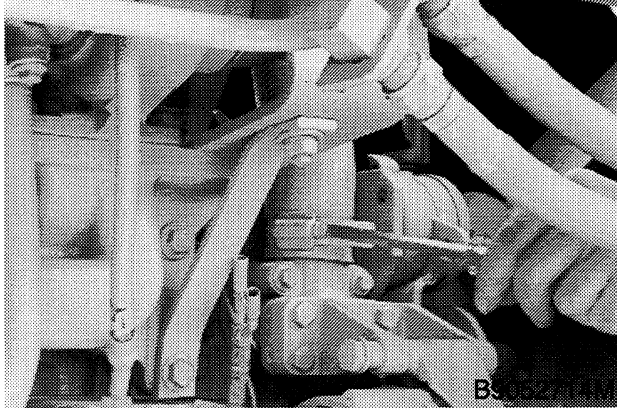

Connect the top radiator hose to the engine.

STEP 44

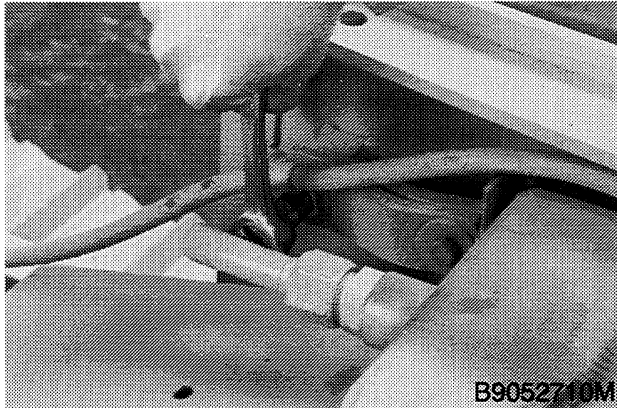

Install the cap screws and flat washers that fasten the top radiator supports to the radiator shroud. A clamp for the drain hose is installed on the cap screw for the top radiator support on the left side of the radiator shroud. Tighten the cap screw.

STEP 45

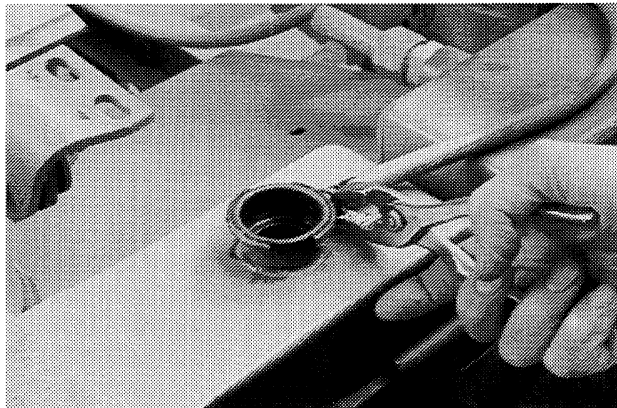

Connect the drain hose to the fill neck of the radiator.

STEP 46

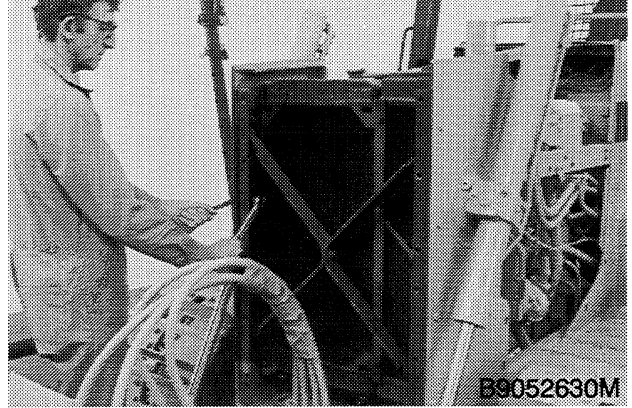

Install both grille mounts and the hardware that fastens both grille mounts to the radiator shroud. Install the cross brace and the hardware for the cross brace. Tighten all of the hardware.

NOTE: *If the machine is equipped with a brush guard, do steps 47, 48, and 49. If the machine is not equipped with a brush guard, go to step 50.*

STEP 47

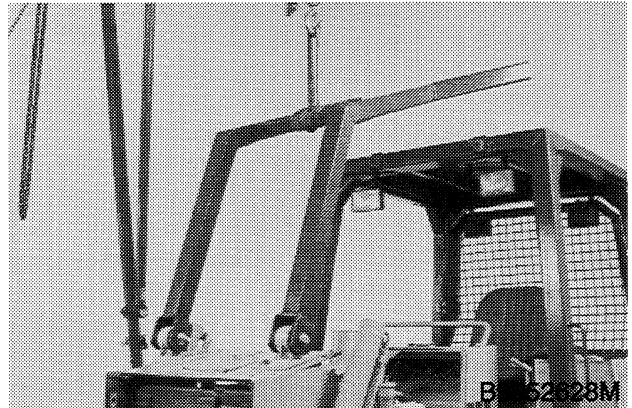

Move the brush guard and top plate into position.

STEP 48

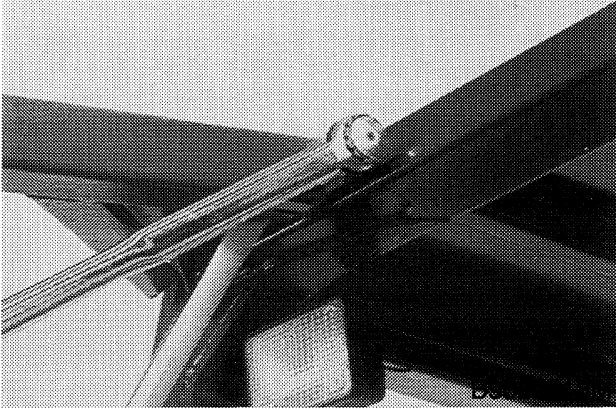

Install the bolts and self-locking nuts that fasten the rear of the brush guard to the ROPS cab or ROPS canopy. Tighten the bolts to 350 to 400 pound-feet (474 to 542 Nm).

STEP 49

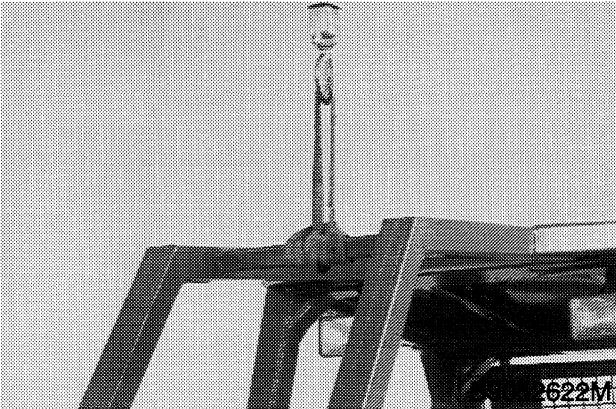

Disconnect and remove the lifting equipment from the brush guard.

STEP 50

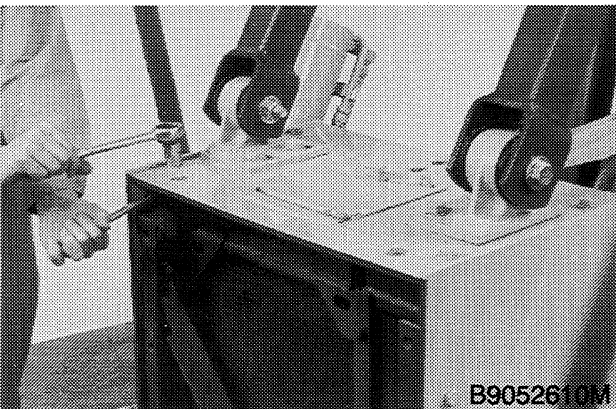

If the machine is not equipped with a brush guard, install the top plate. Install the bolts and nuts that fasten the top plate to both sides of the radiator shroud. Tighten the bolts.

STEP 51

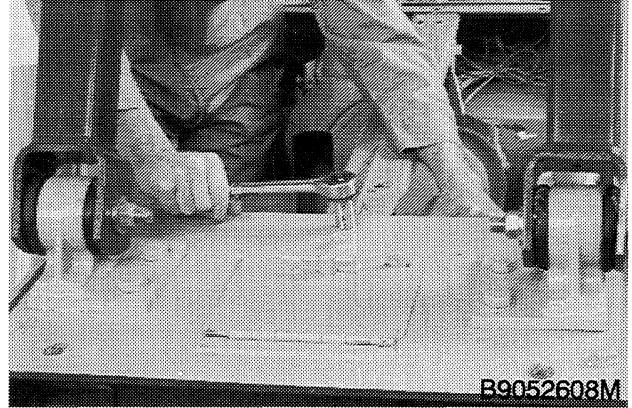

Install the bolts, hardened washers, and self-locking nuts that fasten the center hood brace to the top plate. Tighten the bolts.

STEP 52



Install the right side and the left side of the hood.

STEP 53



Install the cap screws that fasten both sides of the hood. Tighten the cap screws.

STEP 54

B9052532M

Install the extension pipe for the muffler and tighten the clamp.

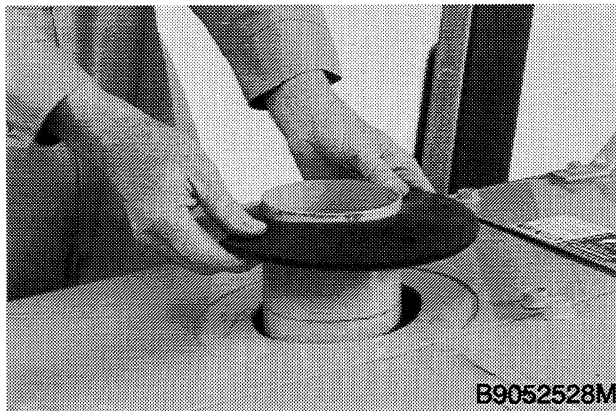
STEP 55

B9052528M

Install the grommet.

STEP 56

B9052524M

Install the precleaner.

STEP 57

Make sure that the drain valve at the front of the radiator is closed. Fill the cooling system with coolant. If new coolant is being installed, the coolant must be at least half permanent antifreeze. The cooling system holds 20 U.S. quarts (18.9 litres). See Section 1002. Install the radiator cap.

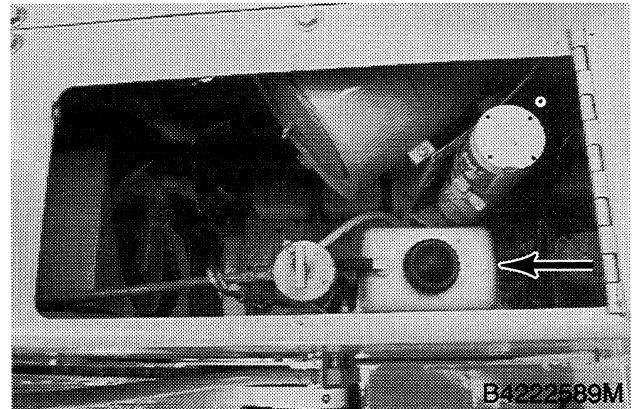
STEP 58

B4222589M

Make sure the coolant reservoir is filled with coolant up to the FULL mark. Start the engine and run the engine at low idle. Check to see that the gauges show the correct indication. Check for coolant and oil leaks. Stop the engine. Let the engine cool and check the level of the coolant reservoir. Add coolant as required.

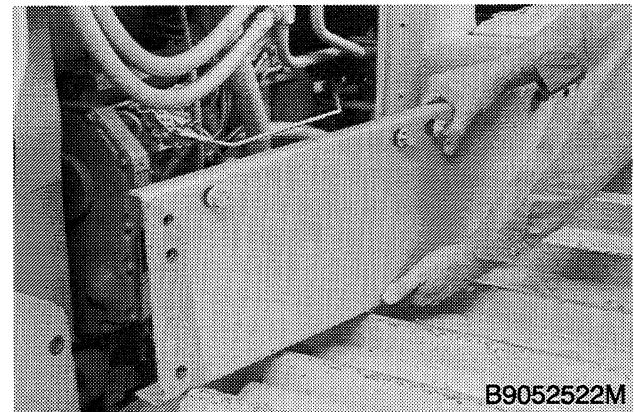
STEP 59

B9052522M

Install the bottom side panel and install and tighten the cap screws.

STEP 60

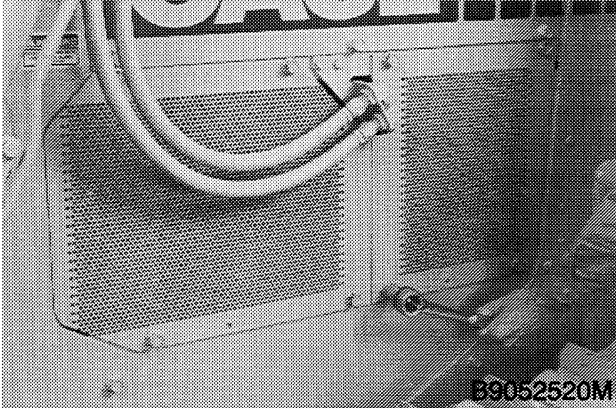

Install the top side panel and install and tighten the cap screws.

STEP 61

Repeat steps 59 and 60 for the bottom side panel and the top side panel on the right side of the machine.

STEP 62

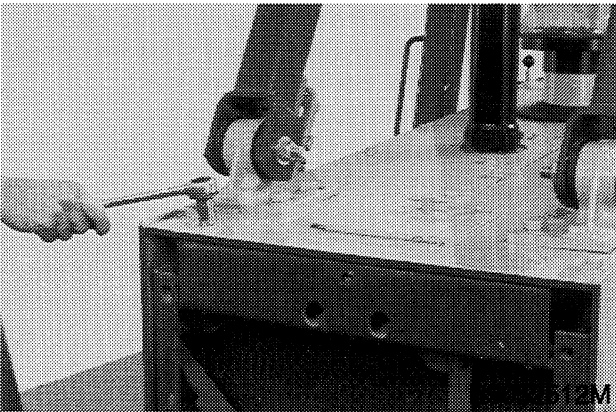

Install the baffle and the cap screws that fasten the baffle to the top of the radiator shroud. Tighten the cap screws.

STEP 63

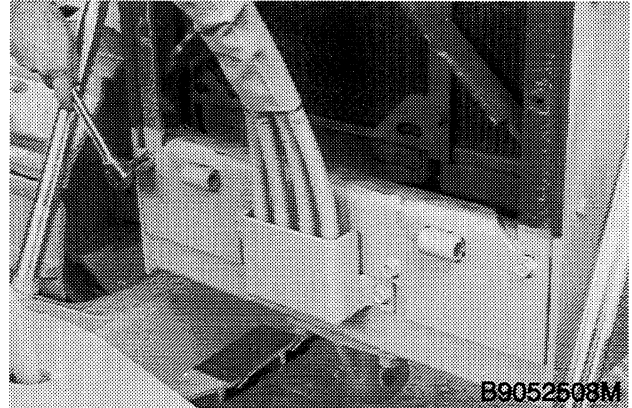

Install the mounting bracket and the cap screws that hold the mounting bracket. Tighten the cap screws.

STEP 64

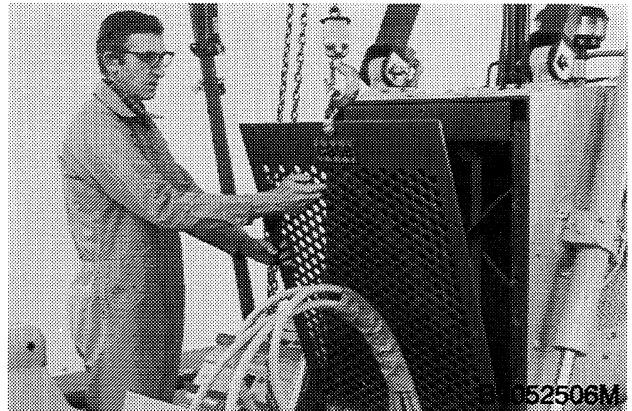

Install the bottom of the grille in the mounting bracket. Disconnect and remove the lifting equipment from the grille.

STEP 65

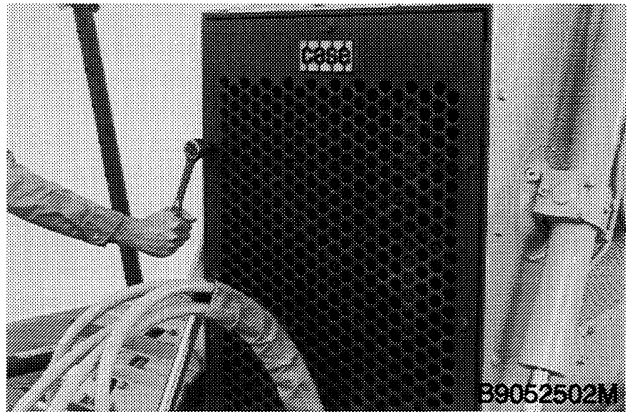

Install and tighten the cap screws that hold the grille.

ENGINE REMOVAL

STEP 66

See Radiator Removal in this section and do steps 1 through 36.

STEP 67

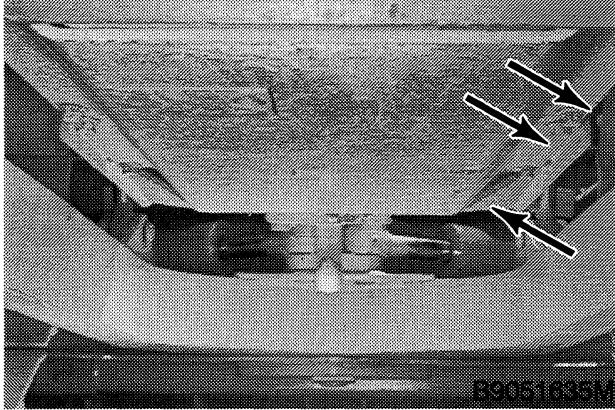

Remove the guards below the engine and torque converter.

- a. Loosen the cap screws that fasten one of the guards to the frame.
- b. Use a floor jack to hold the guards in place and remove the cap screws.
- c. Lower the guard and remove the guard from under the machine.
- d. Repeat this procedure for the remaining guards.

STEP 68

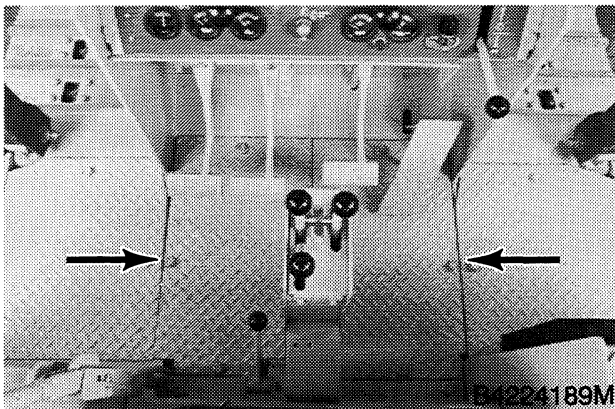

Disconnect the linkage from the accelerator pedal on the floor plate shown. Loosen and remove the cap screws that hold both inner floor plates and remove the inner floor plates.

STEP 69

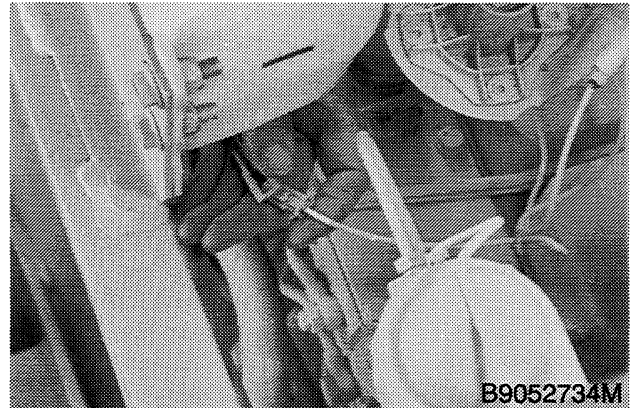

If the machine is equipped with ether injection, disconnect the wire harness.

STEP 70

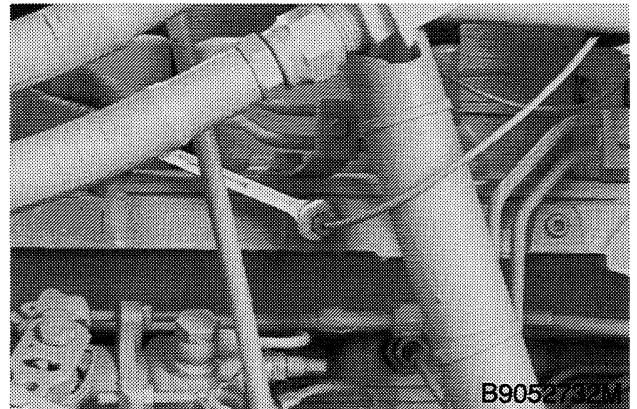

If the machine is equipped with ether injection, disconnect the tube fitting from the intake manifold.

STEP 71

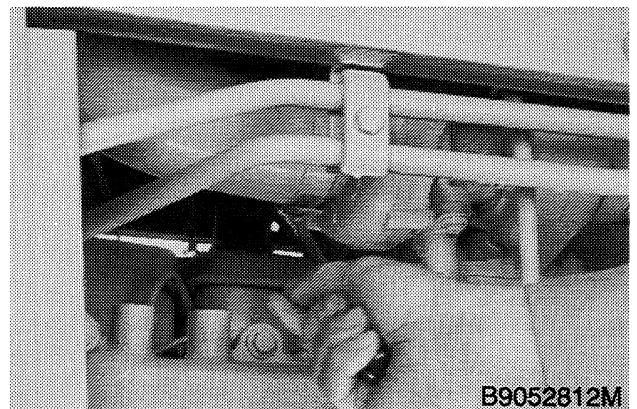

Loosen the clamp and disconnect the hose for the air cleaner from the turbocharger.

STEP 72

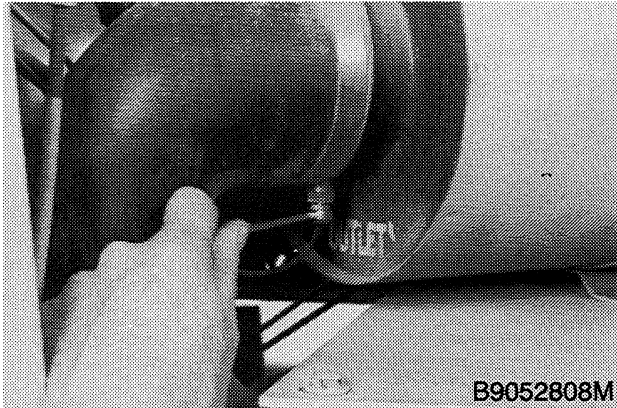

Disconnect the tube for the air restriction indicator from the air cleaner.

STEP 75

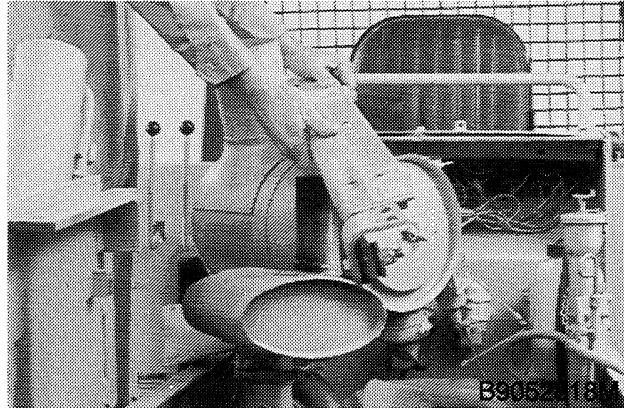

Remove the center hood brace, air cleaner, and ether injection assembly if equipped, from the machine.

STEP 73

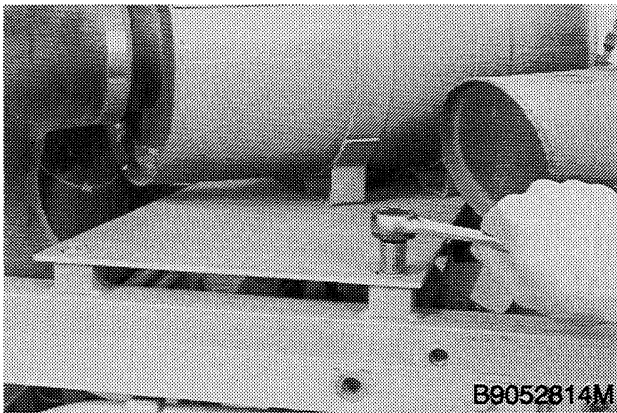

Loosen and remove the cap screws that hold the mounting bracket for the air cleaner.

STEP 76

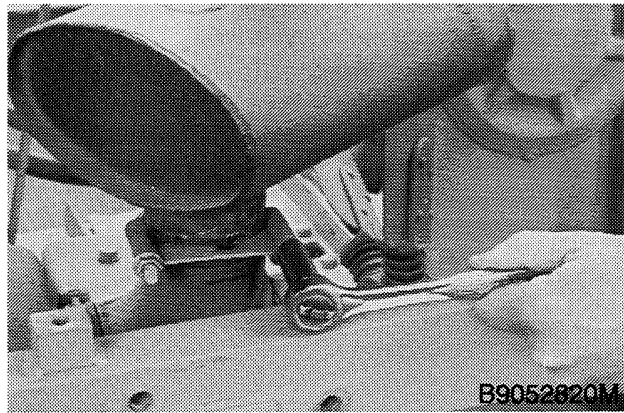

Loosen the nuts on the U-bolt for the muffler clamp.

STEP 74

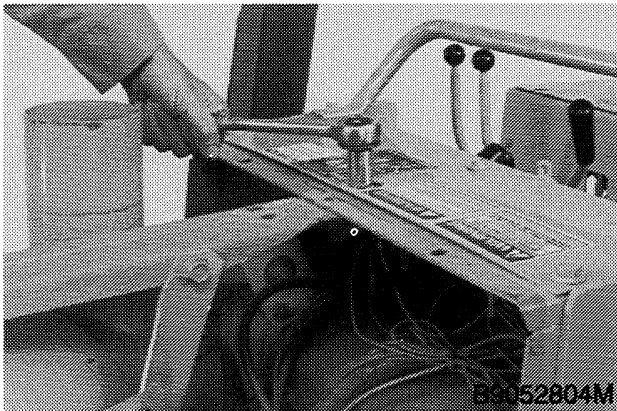

Loosen and remove the cap screw that holds the rear of the center hood brace.

STEP 77

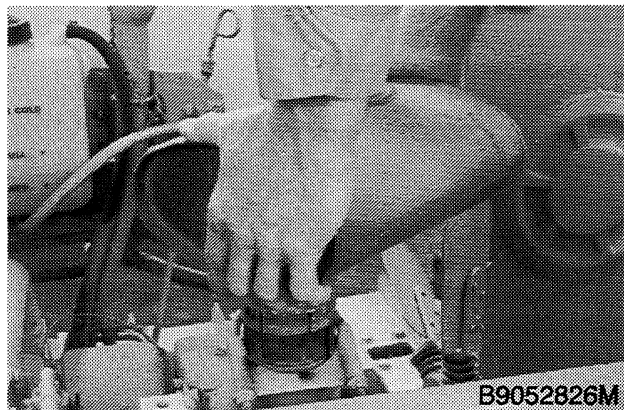

Remove the muffler. Cover or close the opening in the exhaust elbow.

STEP 78

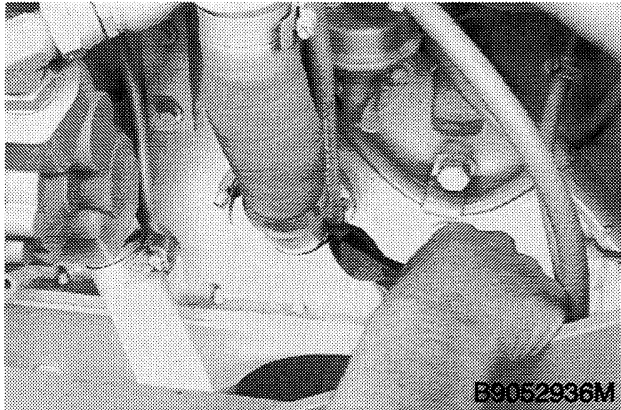

Cut the tie strap that fastens the hose for the coolant reservoir to the oil fill tube.

STEP 81

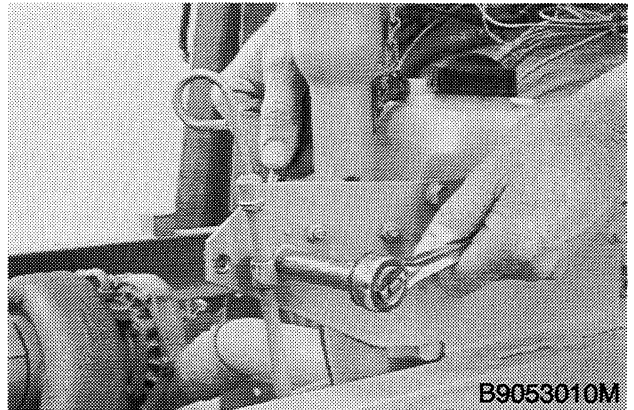

Loosen and remove the self-locking nut, bolt, flat washer, and grommet that hold the clamp for the dipstick tube.

STEP 79

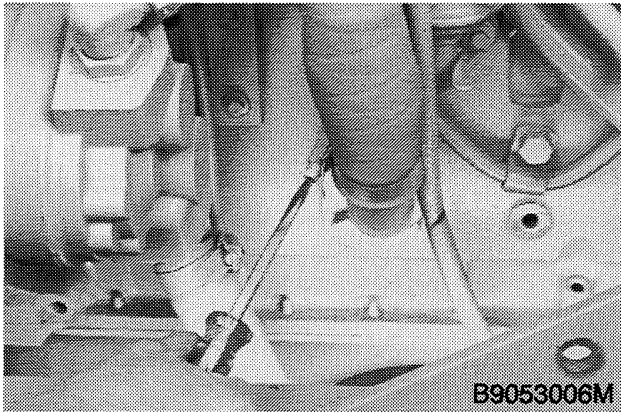

Loosen the hose clamp for the lower oil fill tube.

STEP 82

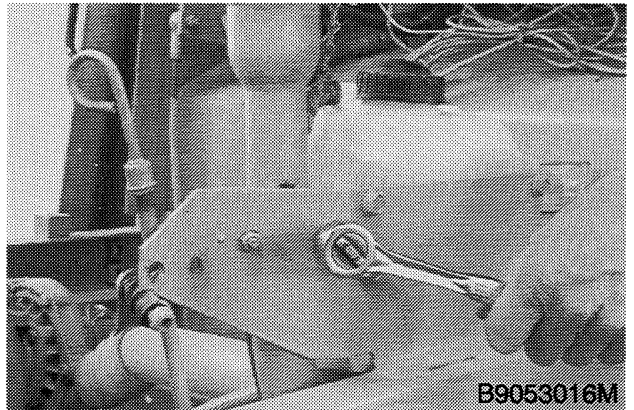

Loosen and remove the nuts and U-bolt that hold the oil fill tube.

STEP 80

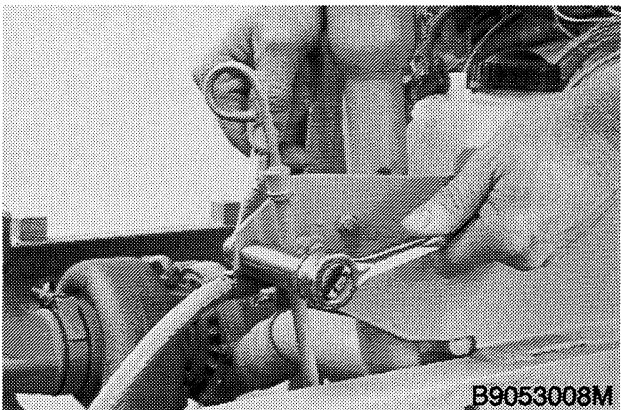

Loosen and remove the self-locking nut and bolt that holds the clamp for the hose to the coolant reservoir.

STEP 83

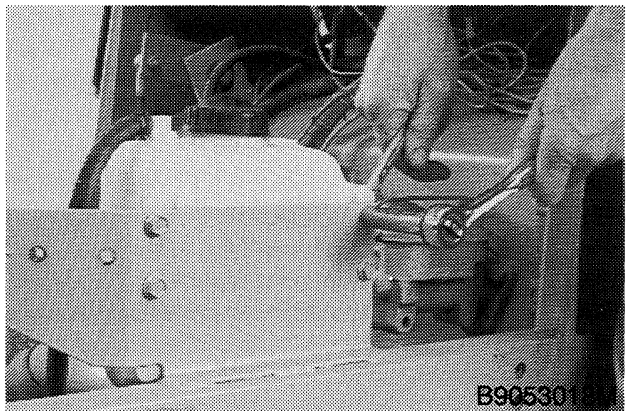

Loosen and remove the self-locking nuts, flat washers, and bolts that hold the coolant reservoir.

STEP 84

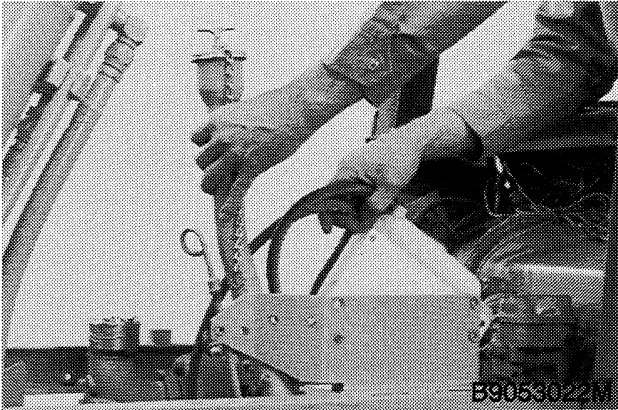

Remove the oil fill tube and coolant reservoir.

STEP 87

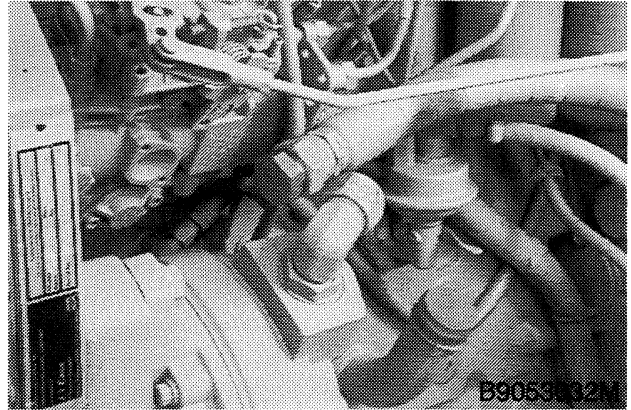

Install a plug in the hose and a cap on the fitting.

STEP 85

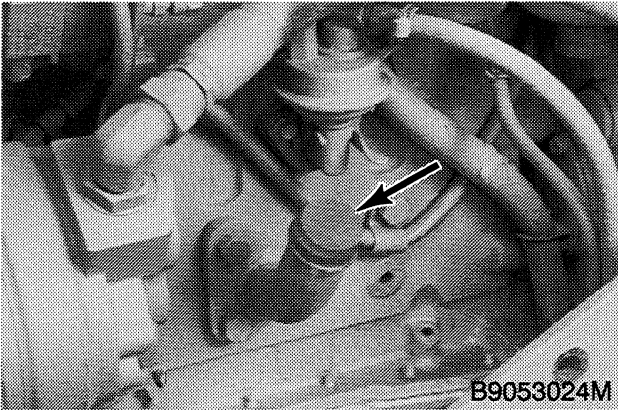

Install a cap on the lower oil fill tube.

STEP 88

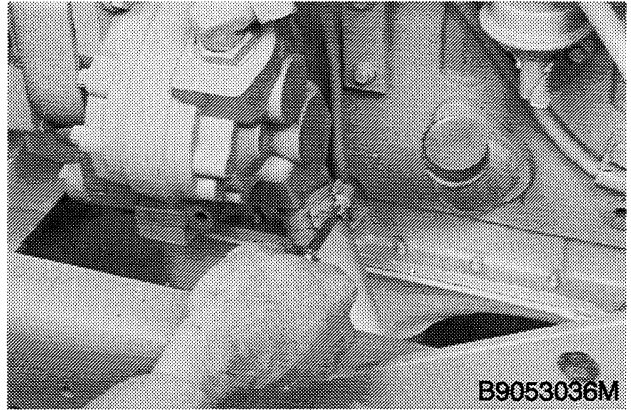

Disconnect the bottom hose.

STEP 86

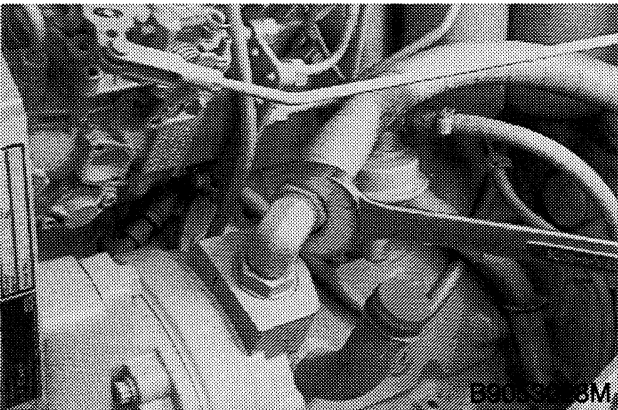

Disconnect the top hose.

STEP 89

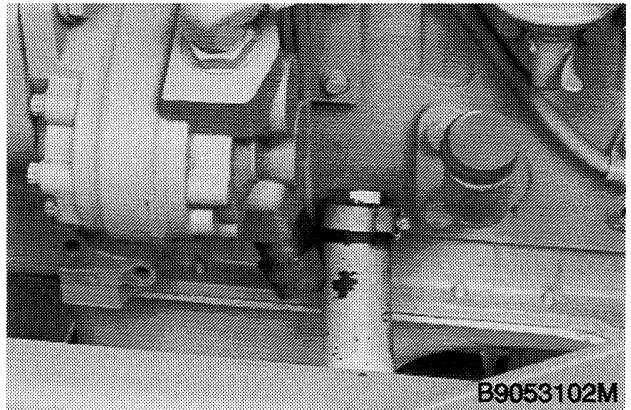

Install a plug in the hose and a cap on the fitting.



Suggest:

If the above button click is invalid.

Please download this document

first, and then click the above link

to download the complete manual.

Thank you so much for reading

STEP 90

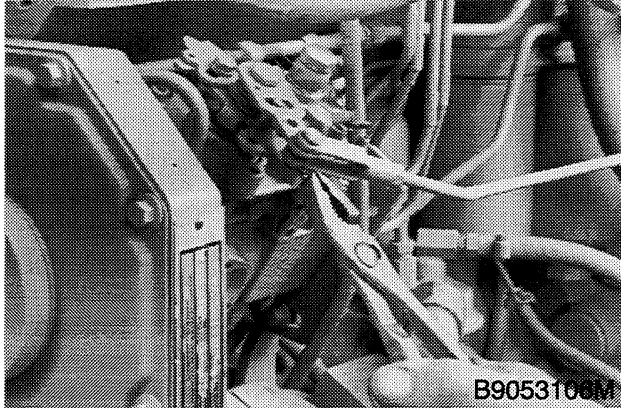

Disconnect the throttle rod from the lever on the fuel injection pump. Move the throttle rod out of the way.

STEP 91

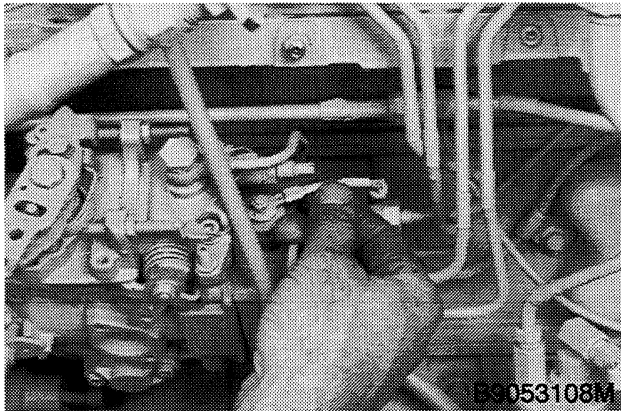

Disconnect the wire for the fuel shutoff solenoid on the fuel injection pump.

STEP 92

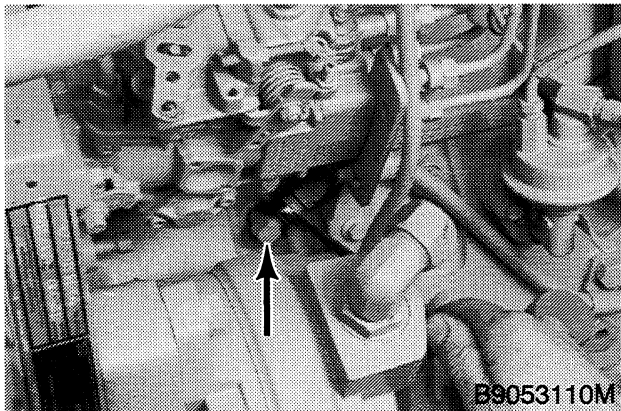

Disconnect the hose for the oil pressure from the fitting in the side of the engine. Install a plug in the hose and a cap on the fitting. Loosen and remove the cap screw and lock washer that fasten the clamp for the hose to the side of the engine. Move the hose out of the way.

STEP 93

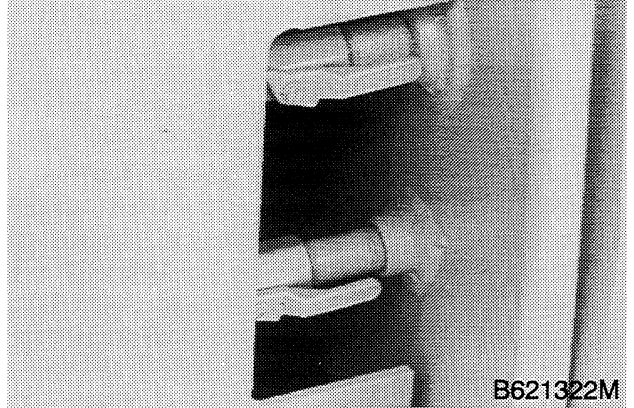

Close the shutoff valves for the fuel supply line and the fuel return line. The shutoff valves are closed when the levers are vertical.

STEP 94

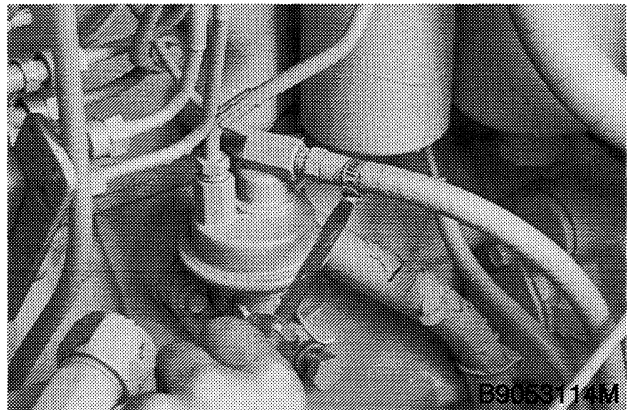

Disconnect the fuel supply hose from the hand primer pump. Install a plug in the hose and a cap on the fitting.

STEP 95

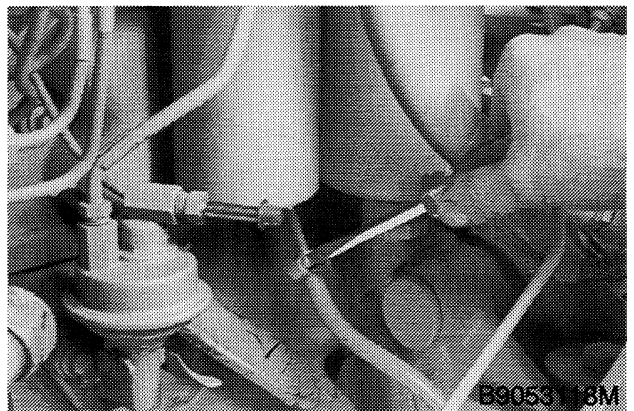

Disconnect the fuel return hose. Install a plug in the hose and a cap on the tube.

<https://www.ebooklibonline.com>

Hello dear friend!

Thank you very much for reading.

Enter the link into your browser.

The full manual is available for immediate download.

<https://www.ebooklibonline.com>