

621G
721G
Tier 4B (final)
Wheel Loader

SERVICE MANUAL

Part number 51428265
2nd edition English
December 2017





SERVICE MANUAL

621G WHEEL LOADER XR-EH, NEW CAB TIER4B NA, 621G WHEEL LOADER XT-EH, NEW CAB TIER4B NA, 621G WHEEL LOADER ZBAR-EH, NEW CAB TIER4B NA, 721G WHEEL LOADER XR-EH, NEW CAB TIER4B NA, 721G WHEEL LOADER XT-EH, NEW CAB TIER4B NA, 721G WHEEL LOADER ZBAR-EH, NEW CAB TIER4B NA

Link Product / Engine

Product	Market Product	Engine
621G WHEEL LOADER ZBAR-EH, NEW CAB TIER4B NA	North America	F4HFE613W*B002
621G WHEEL LOADER XT-EH, NEW CAB TIER4B NA	North America	F4HFE613W*B002
621G WHEEL LOADER XR-EH, NEW CAB TIER4B NA	North America	F4HFE613W*B002
721G WHEEL LOADER ZBAR-EH, NEW CAB TIER4B NA	North America	F4HFE613T*B001
721G WHEEL LOADER XT-EH, NEW CAB TIER4B NA	North America	F4HFE613T*B001
721G WHEEL LOADER XR-EH, NEW CAB TIER4B NA	North America	F4HFE613T*B001

<https://www.ebooklibonline.com>

Hello dear friend!

Thank you very much for reading.

Enter the link into your browser.

The full manual is available for immediate download.

<https://www.ebooklibonline.com>

Contents

INTRODUCTION

Engine	10
[10.001] Engine and crankcase	10.1
[10.202] Air cleaners and lines	10.2
[10.500] Selective Catalytic Reduction (SCR) exhaust treatment	10.3
[10.400] Engine cooling system	10.4
[10.414] Fan and drive	10.5
[10.310] Aftercooler.....	10.6
[10.304] Engine lubrication system.....	10.7
Transmission	21
[21.113] Powershift transmission	21.1
[21.135] Powershift transmission external controls.....	21.2
[21.105] Powershift transmission hydraulic components	21.3
[21.155] Powershift transmission internal components.....	21.4
[21.109] Transmission cooler and lines.....	21.5
[21.700] Torque converter	21.6
[21.182] Differential.....	21.7
Four-Wheel Drive (4WD) system	23
[23.314] Drive shaft.....	23.1
Front axle system	25
[25.100] Powered front axle	25.1
[25.102] Front bevel gear set and differential	25.2
[25.108] Final drive hub, steering knuckles, and shafts	25.3
Rear axle system	27
[27.100] Powered rear axle.....	27.1
[27.106] Rear bevel gear set and differential	27.2

[27.120] Planetary and final drives	27.3
Brakes and controls	33
[33.202] Hydraulic service brakes	33.1
[33.110] Parking brake or parking lock	33.2
Hydraulic systems.....	35
[35.000] Hydraulic systems.....	35.1
[35.300] Reservoir, cooler, and filters.....	35.2
[35.106] Variable displacement pump	35.3
[35.359] Main control valve	35.4
[35.357] Pilot system	35.5
[35.204] Remote control valves	35.6
[35.752] Hydraulic fan drive cooling system.....	35.7
[35.820] Hydraulic driven cooling fans	35.8
[35.355] Hydraulic hand control	35.9
[35.701] Front loader arm hydraulic system	35.10
[35.723] Front loader bucket hydraulic system	35.11
[35.734] Tool quick coupler hydraulic system	35.12
Frames and ballasting	39
[39.100] Frame	39.1
Steering.....	41
[41.101] Steering control	41.1
[41.200] Hydraulic control components.....	41.2
[41.216] Cylinders	41.3
[41.910] Auxiliary steering	41.4
Wheels	44
[44.511] Front wheels.....	44.1
[44.520] Rear wheels.....	44.2
Cab climate control	50

[50.200] Air conditioning.....	50.1
Electrical systems	55
[55.000] Electrical system	55.1
[55.100] Harnesses and connectors.....	55.2
[55.015] Engine control system.....	55.3
[55.201] Engine starting system	55.4
[55.301] Alternator.....	55.5
[55.302] Battery.....	55.6
[55.988] Selective Catalytic Reduction (SCR) electrical system	55.7
[55.989] Exhaust Gas Recirculation (EGR) electrical system	55.8
[55.640] Electronic modules	55.9
[55.024] Transmission control system.....	55.10
[55.020] Transmission speed sensors.....	55.11
[55.022] Transmission temperature sensors	55.12
[55.028] Transmission fluid sensors.....	55.13
[55.512] Cab controls.....	55.14
[55.415] Loader arm and bucket control system	55.15
[55.530] Camera.....	55.16
[55.DTC] FAULT CODES.....	55.17
Front loader and bucket.....	82
[82.100] Arm.....	82.1
[82.300] Bucket.....	82.2
Platform, cab, bodywork, and decals.....	90
[90.150] Cab.....	90.1



INTRODUCTION

Safety rules

621G WHEEL LOADER XR-EH, NEW CAB TIER4B NA	NA
621G WHEEL LOADER XT-EH, NEW CAB TIER4B NA	NA
621G WHEEL LOADER ZBAR-EH, NEW CAB TIER4B NA	NA

Personal safety





This is the safety alert symbol. It is used to alert you to potential personal injury hazards. Obey all safety messages that follow this symbol to avoid possible death or injury.

Throughout this manual you will find the signal words DANGER, WARNING, and CAUTION followed by special instructions. These precautions are intended for the personal safety of you and those working with you.

Read and understand all the safety messages in this manual before you operate or service the machine.

 DANGER indicates a hazardous situation that, if not avoided, will result in death or serious injury.

 WARNING indicates a hazardous situation that, if not avoided, could result in death or serious injury.

 CAUTION indicates a hazardous situation that, if not avoided, could result in minor or moderate injury.

FAILURE TO FOLLOW DANGER, WARNING, AND CAUTION MESSAGES COULD RESULT IN DEATH OR SERIOUS INJURY.

Machine safety

NOTICE: Notice indicates a situation that, if not avoided, could result in machine or property damage.

Throughout this manual you will find the signal word Notice followed by special instructions to prevent machine or property damage. The word Notice is used to address practices not related to personal safety.

Information

NOTE: Note indicates additional information that clarifies steps, procedures, or other information in this manual.

Throughout this manual you will find the word Note followed by additional information about a step, procedure, or other information in the manual. The word Note is not intended to address personal safety or property damage.

Personal safety

Carefully read this Manual before proceeding with maintenance, repairs, refuelling or other machine operations.

Repairs have to be carried out only by authorized and instructed staff; specific precautions have to be taken when grinding, welding or when using mallets or heavy hammers.

Non-authorized persons are not allowed to repair or carry out maintenance on this machine. Do not carry out any work on the equipment without prior authorization.

Ask your employer about the safety instructions in force and safety equipment.

Nobody should be allowed in the cab during machine maintenance unless he is a qualified operator helping with the maintenance work.

If it is necessary to move the equipment to carry out repairs or maintenance, do not lift or lower the equipment from any other position than the operator's seat.

Never carry out any operation on the machine when the engine is running, except when specifically indicated.

Stop the engine and ensure that all pressure is relieved from hydraulic circuits before removing caps, covers, valves, etc.

All repair and maintenance operations should be carried out with the greatest care and attention.

Service stairs and platforms used in a workshop or in the field should be built in compliance with the safety rules in force.

Any functional disorders, especially those affecting the safety of the machine, should therefore be rectified immediately.

⚠ DANGER

Unexpected movement!

Make sure parking brake is applied. Secure machine with wheel chocks.

Failure to comply will result in death or serious injury.

D0013A

Before performing any work on the machine, attach a maintenance in progress tag. This tag can be applied on the left-hand control lever, safety lever or cab door.

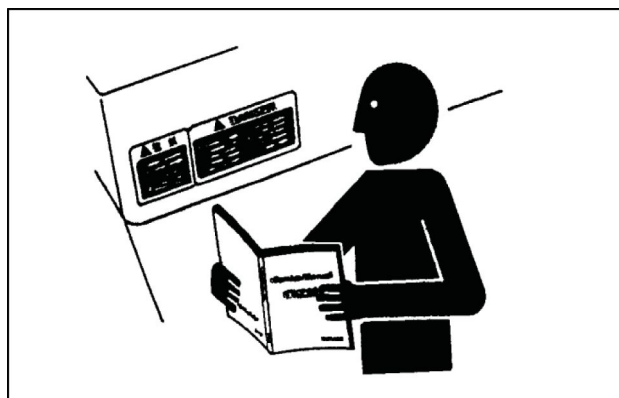

TULI12WEX2004AA 1

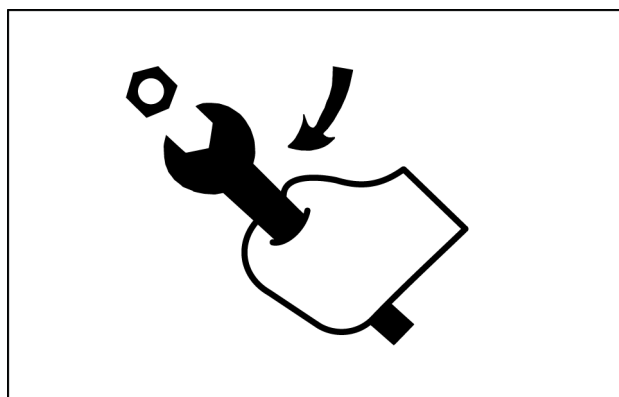

TULI12WEX2005AA 2

Emergency

Be prepared for emergencies. Always keep a fire extinguisher and first aid kit readily available. Ensure that the fire extinguisher is serviced in accordance with the manufacturer's instructions.

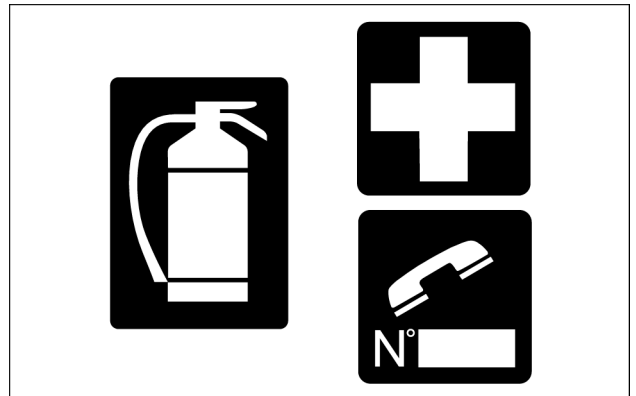

SMIL12WEX0174AA 3

Equipment

Wear close fitting clothing and safety equipment appropriate for the job:

- Safety helmet
- Safety shoes
- Heavy gloves
- Reflective clothing
- Wet weather clothing

If working conditions require, the following personal safety equipment should be on hand:

- Respirators (or dust proof masks)
- Ear plugs or acoustic ears protections
- Goggles with lateral shield or masks for eye protection

Do not wear rings, wristwatches, jewelry, unbuttoned or flapping clothing such as ties, torn clothes, scarves, open jackets or shirts with open zips which could get caught into moving parts.

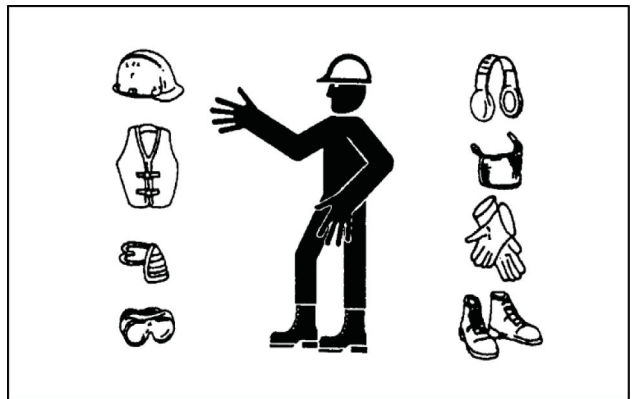

TULI12WEX2008AA 4

Engine - Radiator

Never leave the engine running in enclosed spaces without proper ventilation which is able to evacuate toxic exhaust gases- Keep the exhaust manifold and tube free from combustible materials.

Do not refuel with the engine running, especially if hot, as this increases fire hazard in case of fuel spillage.

Never attempt to check or adjust the belts when the engine is running.

Never lubricate the machine with the engine running.

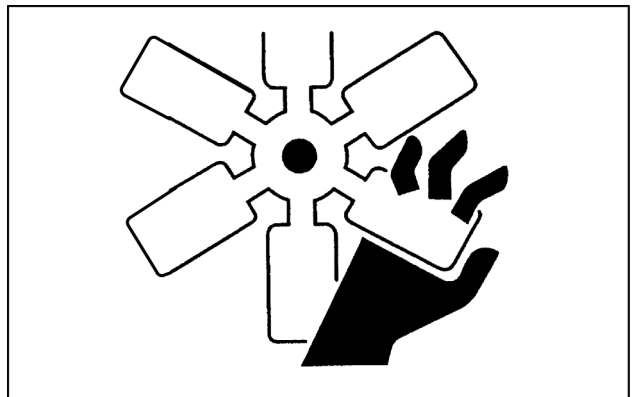

TULI12WEX2009AA 5

Pay attention to rotating components and do not allow anyone to approach these areas to avoid becoming entangled.

Hands, clothing or tools getting caught in the fan blades or engine belts, can cause amputations, violent hemorrhages and generate conditions of grave danger. For this reason avoid touching or approaching all rotating or moving parts.

A surging spray of the coolant from the radiator can cause serious burns and scalds.

Before checking the coolant level, shut-off the engine and allow machine to cool down the radiator and hoses. Slowly unscrew the cap to release any residual pressure.

If it is necessary to remove the cap while engine is hot, wear safety clothes and equipment, then loosen the cap slowly to relieve the pressure gradually.

When checking the fuel, oil and coolant levels, use lights and lamps explicitly designated as explosion proof. If these types of lamps are not used, fires or explosions may occur.

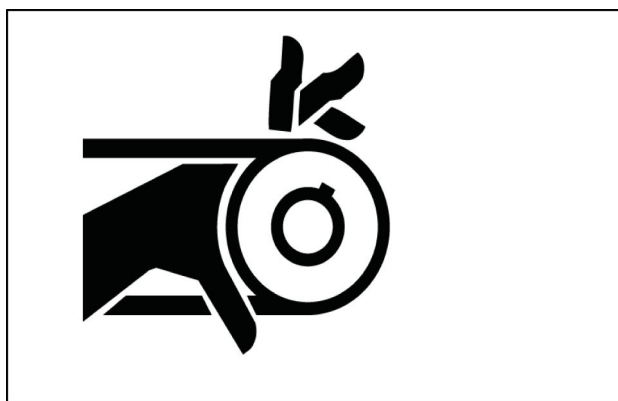

TUL12WEX2010AA 6

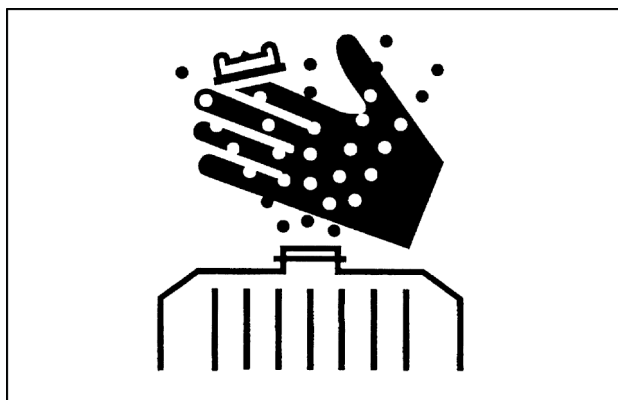

TUL12WEX2011AA 7

Hydraulic systems

Jets of fluids under pressure can penetrate the skin causing serious injuries.

Avoid this hazard by relieving pressure before disconnecting hydraulic or other lines.

Relieve the residual pressure by moving the hydraulic control levers several times.

Tighten all connections before applying pressure.

To protect the eyes wear a facial shield or safety goggles.

Protect your hands and body from possible jets of fluids under pressure.

Swallowing hydraulic oil is a severe health hazard.



TUL12WEX2012AA 8

INTRODUCTION

When hydraulic oil has been swallowed, avoid vomiting, but consult a doctor or go to a hospital.

If an accident occurs, see a doctor familiar with this type of injury immediately.

Any fluid penetrating the skin must be removed within a few hours to avoid serious infections.

Flammable splashes may originate because of heating near lines with fluids under pressure, resulting in serious burns. Do not weld or use torches near lines containing fluids or other flammable materials.

Lines under pressure can accidentally be pierced when the heat expands beyond the area immediately heated.

Arrange for temporary fire resistant shields to protect hoses or other components during welding or torch use.

Have any visible leakage repaired immediately.

Discharged oil pollutes the environment. Soak up any oil that has spilled with a proper binding agent. Sweep up binding agent and dispose of it separately from other waste.

Never search for leakages with fingers; instead, use a piece of cardboard and always wear goggles.

Never repair a damaged line; always replace it. Replace hydraulic hoses immediately on detecting any damaged or moist areas.

Always store hydraulic oil in the original containers.

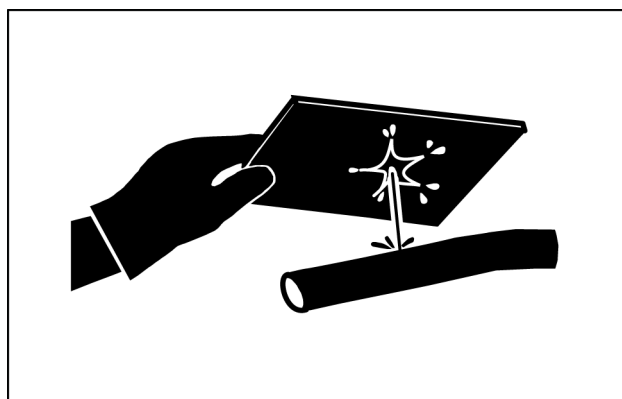

TULI12WEX2013AA 9

Product identification

Machine components

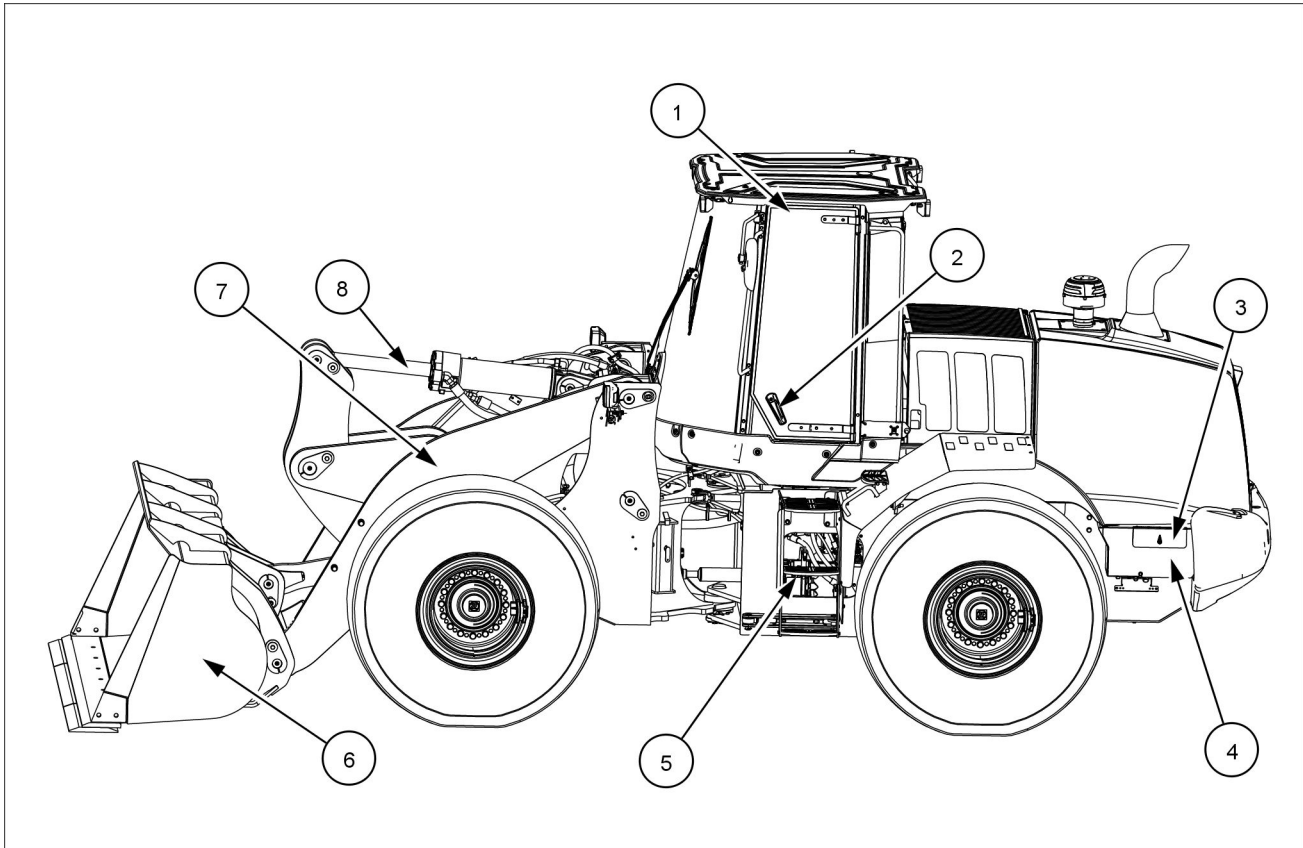

LEIL17WHL1448FA1 1

- | | |
|--------------------------------------------------|---------------------------|
| 1. Roll Over Protection System (ROPS) cab | 5. Steps |
| 2. Cab door handle | 6. Bucket (Z-bar version) |
| 3. Timed disconnect switch and battery jump post | 7. Loader lift arms |
| 4. Battery access | 8. Bucket cylinder |

INTRODUCTION

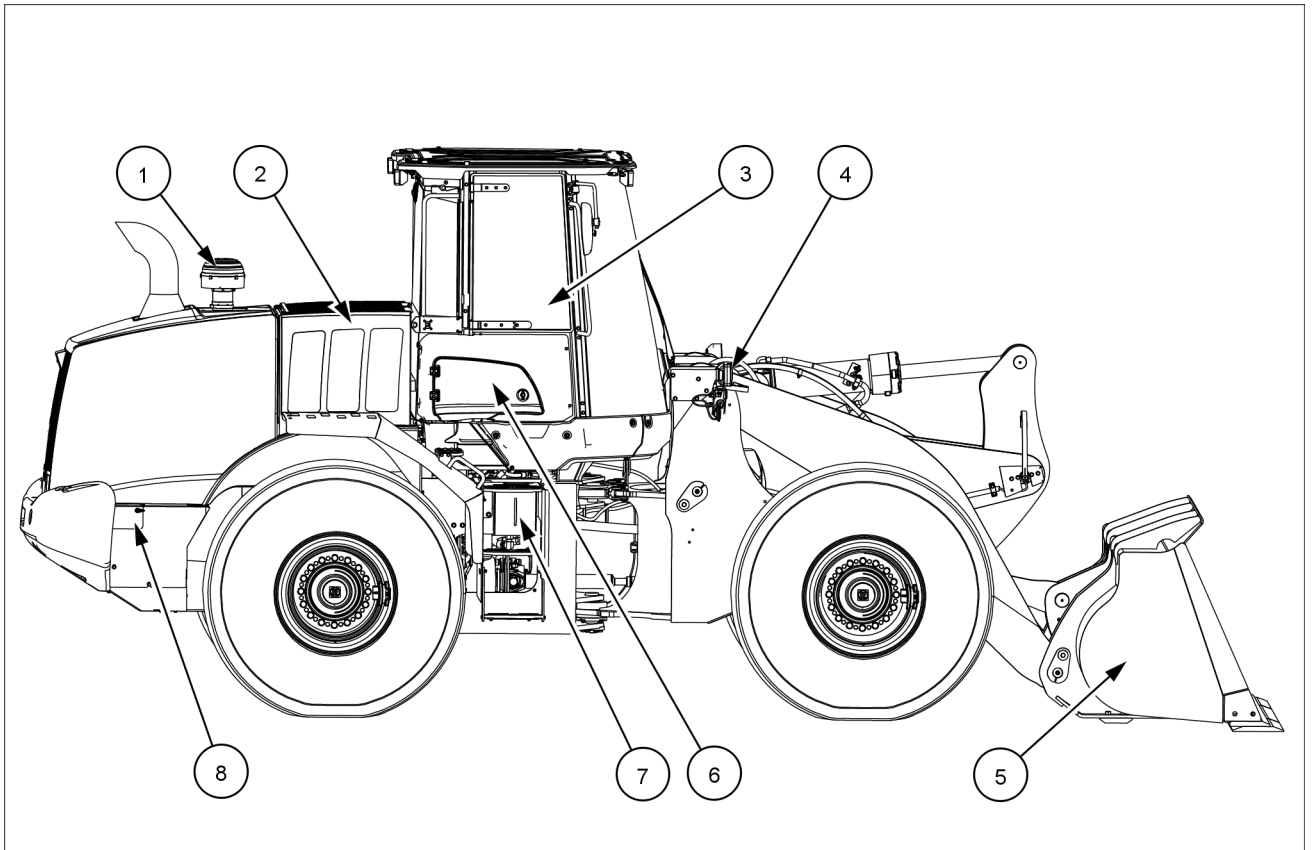

LEIL17WHL1447FA 2

- | | |
|-------------------------|--------------------------------------------------------|
| 1. Pre-cleaner | 5. Bucket (Z-bar version) |
| 2. Sliding access panel | 6. Cab air filter door |
| 3. Cab side window | 7. Windshield washer reservoir |
| 4. Driving lights | 8. DIESEL EXHAUST FLUID (DEF)/AdBLUE® fill tank |



SERVICE MANUAL

Engine

621G WHEEL LOADER XR-EH, NEW CAB TIER4B NA, 621G WHEEL LOADER XT-EH, NEW CAB TIER4B NA, 621G WHEEL LOADER ZBAR-EH, NEW CAB TIER4B NA, 721G WHEEL LOADER XR-EH, NEW CAB TIER4B NA, 721G WHEEL LOADER XT-EH, NEW CAB TIER4B NA, 721G WHEEL LOADER ZBAR-EH, NEW CAB TIER4B NA

Engine - General specification

621G WHEEL LOADER XR-EH, NEW CAB TIER4B NA	NA
621G WHEEL LOADER XT-EH, NEW CAB TIER4B NA	NA
621G WHEEL LOADER ZBAR-EH, NEW CAB TIER4B NA	NA

Engine with 4 Speed Transmission	
A. Low idle	870 RPM to 930 RPM
Alternate low idle	670 RPM to 730 RPM
Alternate Accelerated Idle	1270 RPM to 1330 RPM
B. Maximum No Load RPM	2094 RPM to 2224 RPM
C. Converter Stall	1975 RPM to 2125 RPM
D. Hydraulic Stall	1895 RPM to 2205 RPM
E. Converter & Hydraulic Stall	1455 RPM to 1765 RPM
Temperature of the torque converter oil	82 – 104 °C (180 – 219 °F)
Temperature of the hydraulic oil	54 – 57 °C (129 – 135 °F)

Engine with 5 Speed Transmission	
A. Low idle	870 RPM to 930 RPM
Alternate low idle	670 RPM to 730 RPM
Alternate Accelerated Idle	1270 RPM to 1330 RPM
B. Maximum No Load RPM	2094 RPM to 2224 RPM
C. Converter Stall	2013 RPM to 2163 RPM
D. Hydraulic Stall	1950 RPM to 2150 RPM
E. Converter & Hydraulic Stall	1559 RPM to 1759 RPM
Temperature of the torque converter oil	82 – 104 °C (180 – 219 °F)
Temperature of the hydraulic oil	54 – 57 °C (129 – 135 °F)

NOTE: Hydraulic Stall and Converter & Hydraulic Stall RPM values are read while the lift arms are rising with the bucket held rolled back and the engine at Wide Open Throttle (WOT) in max power mode with transmission in manual mode and in 3rd gear.

Engine - General specification

721G WHEEL LOADER XR-EH, NEW CAB TIER4B NA	NA
721G WHEEL LOADER XT-EH, NEW CAB TIER4B NA	NA
721G WHEEL LOADER ZBAR-EH, NEW CAB TIER4B NA	NA

Engine with 4 Speed Transmission	
A. Low idle	870 RPM to 930 RPM
Alternate low idle	670 RPM to 730 RPM
Alternate Accelerated Idle	1270 RPM to 1330 RPM
B. Maximum No Load RPM	2100 RPM to 2185 RPM
C. Converter Stall	1893 RPM to 2093 RPM
D. Hydraulic Stall	1923 RPM to 2123 RPM
E. Converter & Hydraulic Stall	1500 RPM to 1700 RPM
Temperature of the torque converter oil	82 – 104 °C (180 – 219 °F)
Temperature of the hydraulic oil	54 – 57 °C (129 – 135 °F)

Engine with 5 Speed Transmission	
A. Low idle	870 RPM to 930 RPM
Alternate low idle	670 RPM to 730 RPM
Alternate Accelerated Idle	1270 RPM to 1330 RPM
B. Maximum No Load RPM	2100 RPM to 2185 RPM
C. Converter Stall	1748 RPM to 1948 RPM
D. Hydraulic Stall	1987 RPM to 2187 RPM
E. Converter & Hydraulic Stall	1413 RPM to 1613 RPM
Temperature of the torque converter oil	82 – 104 °C (180 – 219 °F)
Temperature of the hydraulic oil	54 – 57 °C (129 – 135 °F)

NOTE: Hydraulic Stall and Converter & Hydraulic Stall RPM values are read while the lift arms are rising with the bucket held rolled back and the engine at Wide Open Throttle (WOT) in max power mode with transmission in manual mode and in 3rd gear.

Engine - General specification - Engine Service Manual

See below the part number of the Engine FPT F4HFE613W and F4HFE613T Service Manual. See the Engine Service Manual for more details about the engine overhaul.

Language	Engine Service Manual P/N
English	48076871

Engine - Engine horse power

621G WHEEL LOADER XR-EH, NEW CAB TIER4B NA	NA
621G WHEEL LOADER XT-EH, NEW CAB TIER4B NA	NA
621G WHEEL LOADER ZBAR-EH, NEW CAB TIER4B NA	NA

Design characteristics	
Displacement:	6728 cm³ (410.6 in³)
Engine Configuration	6 cylinder in line, 4 stroke
Intake Air	Turbocharged, 4 valves/cyl
Fuel injection	High pressure common rail
EGR	No

Performance	
Altitude Capability	3000 m (9842.5 ft)
High Idle Speed	2212 RPM
Low Idle Speed	700 RPM
Rated Power	121 kW at 2000 RPM
Peak Torque	730 N·m at 1500 RPM

Engine - Engine and crankcase

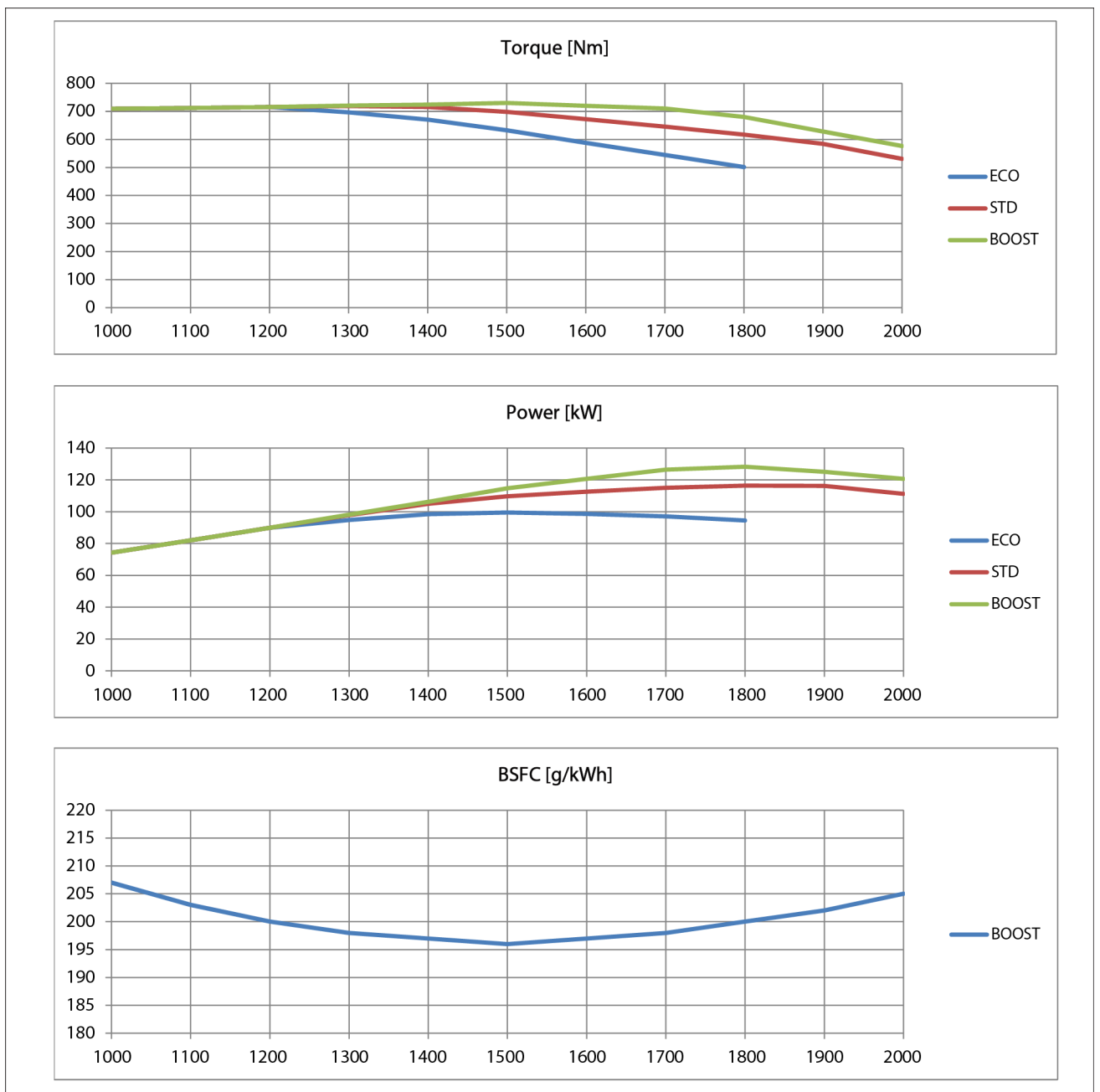

LEIL17WHL0356GA 1

NOTE: performances detected at engine test bench.

NOTE: BSFC indicates the Brake Specific Fuel Consumption.

Engine - Engine horse power

721G WHEEL LOADER XR-EH, NEW CAB TIER4B NA	NA
721G WHEEL LOADER XT-EH, NEW CAB TIER4B NA	NA
721G WHEEL LOADER ZBAR-EH, NEW CAB TIER4B NA	NA

Design characteristics	
Displacement	6728 cm³ (410.6 in³)
Engine Configuration	6 cylinder in line, 4 stroke
Intake Air	Turbocharged, 4 valves/cyl
Fuel injection	High pressure common rail
EGR:	No

Engine - Engine and crankcase

Performance	
Altitude Capability	3000 m (9842.5 ft)
High Idle Speed	2212 RPM
Low Idle Speed	700 RPM
Rated Power	145 kW at 2000 RPM
Peak Torque	950 N·m at 1300 RPM

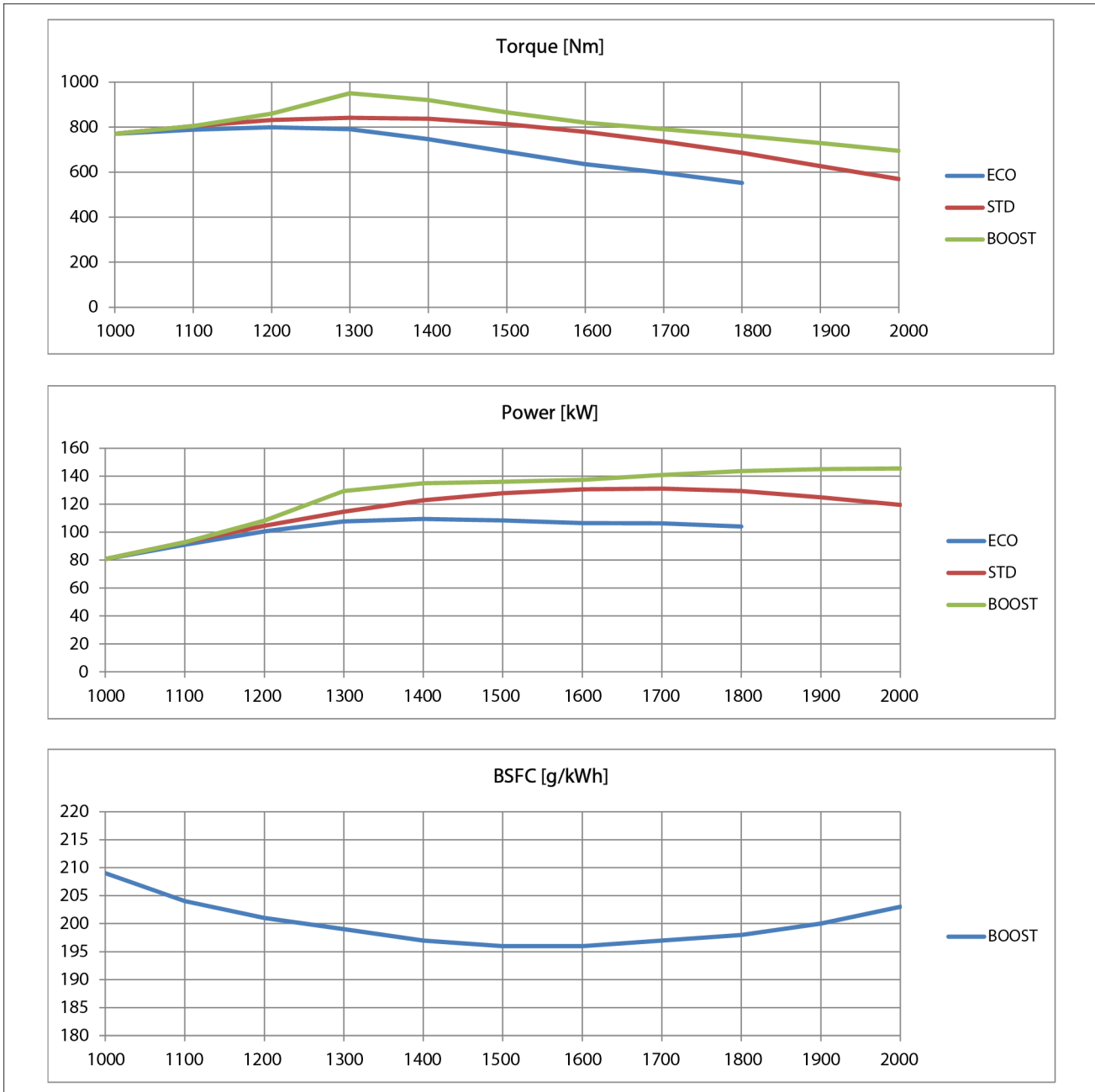

LEIL17WHL0357GA 1

NOTE: these are bench tested power / consumption curves that of course can not reflect the daily and specific use that each operator / business owner makes of an earth moving machine.

NOTE: BSFC indicates the Brake Specific Fuel Consumption.

Engine - Remove

621G WHEEL LOADER XR-EH, NEW CAB TIER4B NA	NA
621G WHEEL LOADER XT-EH, NEW CAB TIER4B NA	NA
621G WHEEL LOADER ZBAR-EH, NEW CAB TIER4B NA	NA

NOTE: emissions sensors mounted in the exhaust stream are sensitive to extreme vibrations. Use of tools that generate extreme vibrations, such as impact wrenches and hammers, will result in damage to emission sensors. Avoid using these tools during any service procedure in close proximity of emission sensors. If the use of these tools cannot be avoided, remove the sensors using extreme caution prior to performing any service procedure.

1. Park the machine on a level surface and lower the bucket to the ground. Put the articulation lock in LOCKED position and stop the engine.

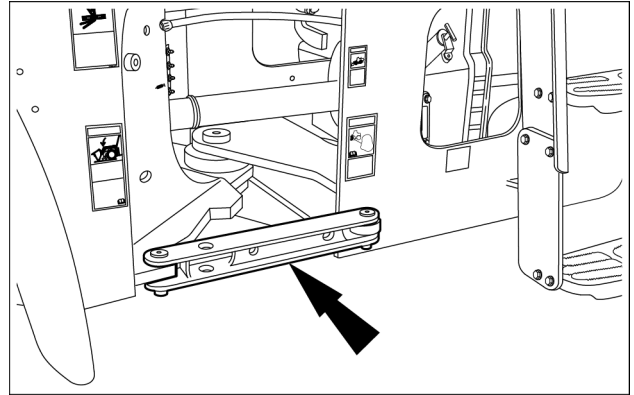

LEIL16WHL0048AB 1

2. Actuate the brake pedal several times to discharge the brake accumulators.

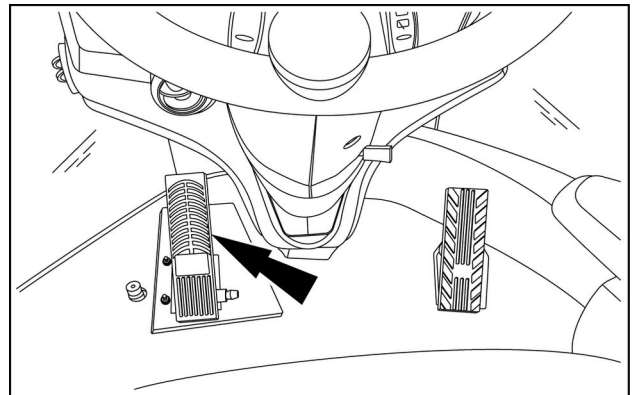

LEIL15WHL0564AA 2

3. Put the key switch in ON position. Put the control switch in ON position. Move the control lever(s) back and forth at least 30 times to release any pressure from the hydraulic circuit. Put the key switch in OFF position.

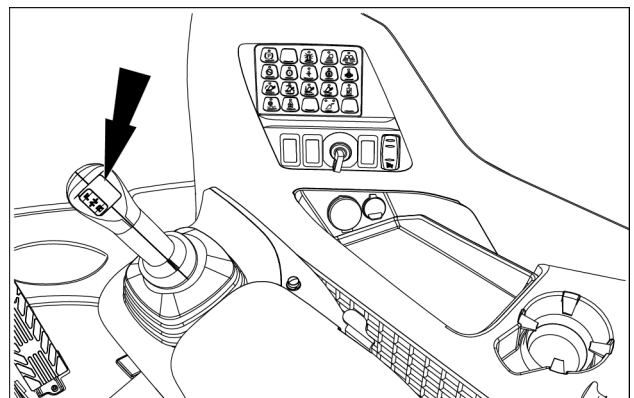

LEIL17WHL1348AA 3

4. Raise the grill located above the cooler box just behind the cab. Then slowly loosen the hydraulic reservoir filler cap to release pressure in the reservoir.

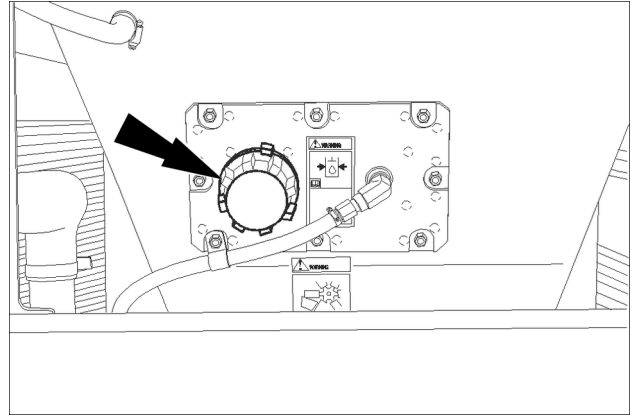

RCPH10WHL099BAL 4

5. Locate the timed disconnect switch and the hood raise switch in the battery box. Raise the engine hood and put the timed disconnect switch in the OFF position.

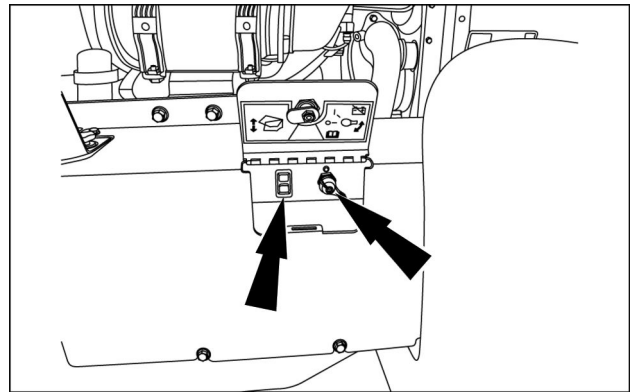

RCPH10WHL106AAH 5

6. Unhook the rubber T-handle (1) and raise the upper panel (2). Make sure that the security levers are blocked.

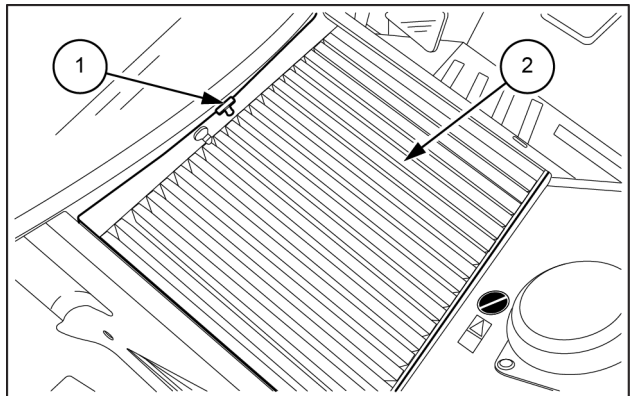

LEIL13WHL0137AB 6

7. Raise both side panels (1). Then remove the thumb screws (2) and inner fender panels (3).

NOTE: right-hand side of the machine is shown. The operation is similar for the left-hand side.

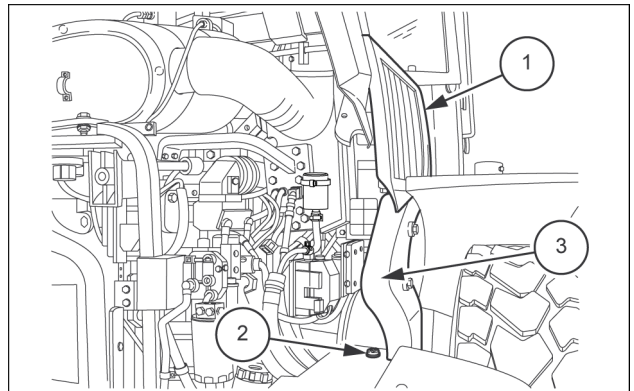

LEIL13WHL0612AB 7

8. Place a suitable container below the radiator drain plug, remove the radiator cap and the radiator drain plug (see the arrow in figure) to drain the engine coolant. Reinstall the radiator drain plug and the radiator cap after coolant has drained.

NOTE: see machine specifications for cooling system volume.

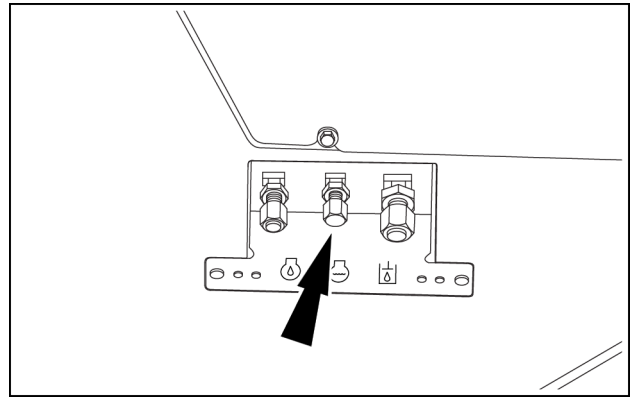

LEIL16WHL0198AA 8

9. Place a suitable container below the engine oil drain plug (see the arrow in figure). Remove the engine oil drain plug and drain oil into container. Reinstall the engine oil drain plug.

NOTE: see machine specifications for engine oil sump volume.

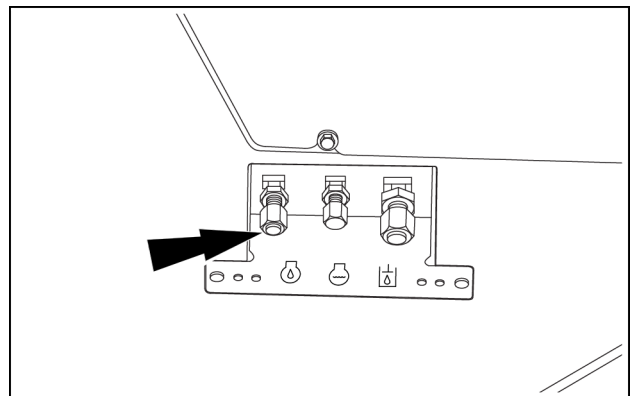

LEIL16WHL0198AA 9

10. Remove the drain hose (1) from the frame bracket (2).

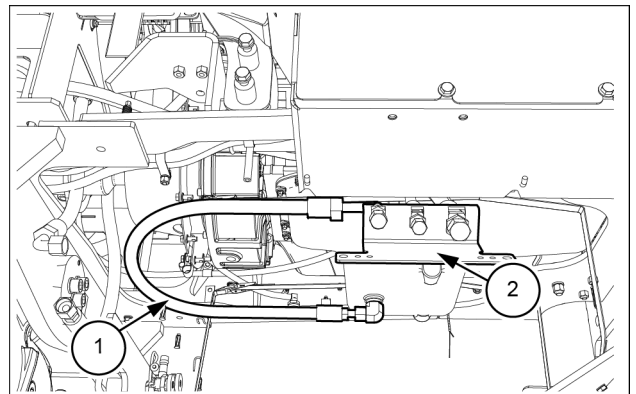

LEIL16WHL1250AB 10

11. Double up a nylon lifting strap and slide through the exhaust stack (1) on the engine hood.

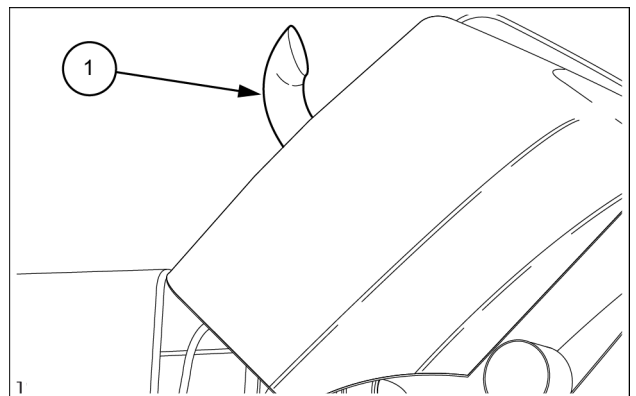

LEIL14WHL0400AB 11

12. Place a solid steel bar or pipe through the strap loop inside the engine hood and attach the strap to a suitable lifting device.
Raise the engine hood with the strap to release tension on the lifting motor.

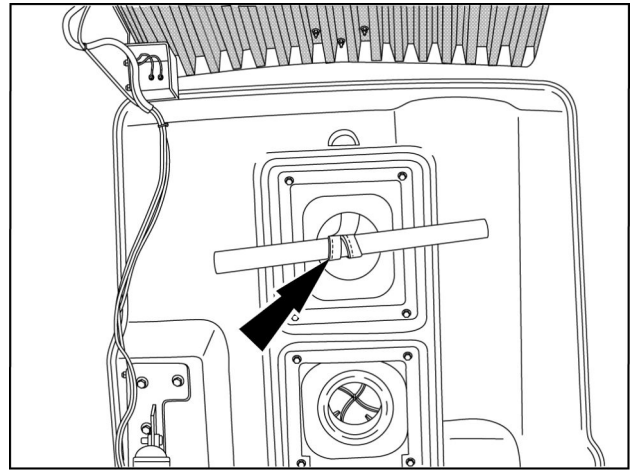

RAPH12WEL0600AA 12

13. If machine is equipped with a rearview camera, tag and disconnect the connector (1) of the rearview camera wire harness (3). Cut the wire ties (2) that hold the rearview camera wire harness (3) to the rear grill.

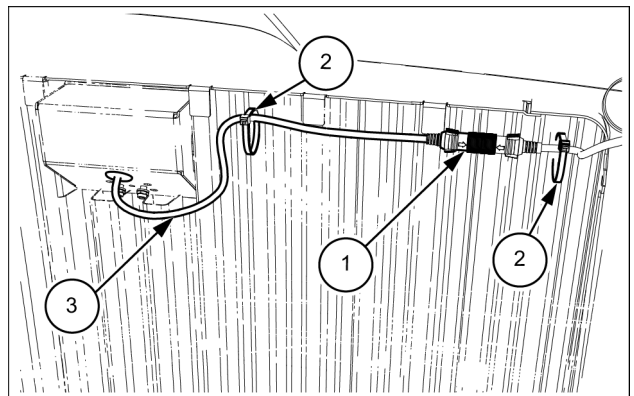

LEIL16WHL0849AB 13

14. Cut the wire ties and remove the rearview camera wire harness from the engine hood. Place the rearview camera wire harness off to the side in a safe location.

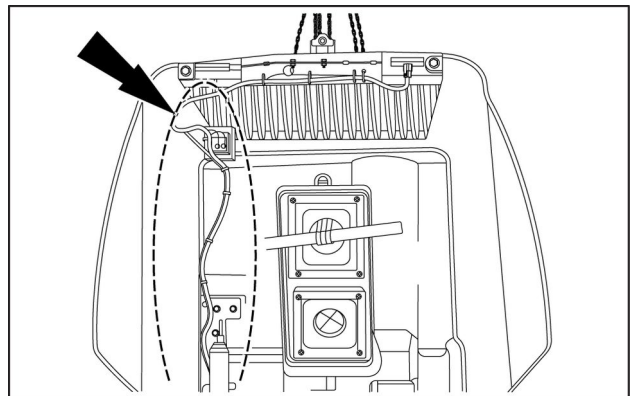

LEIL13WHL0140AB 14

15. Remove the engine hood wire harness clamp (1) from the cooler housing. Tag and remove the engine hood ground wire (2) from cooler housing.

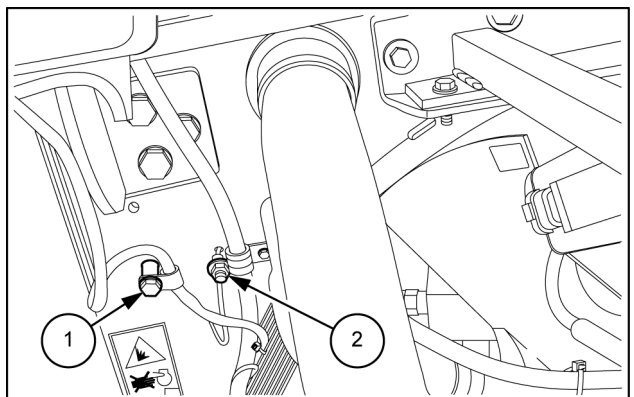

LEIL13WHL0149AB 15

16. Tag and disconnect the engine hood wiring harness connector (1) from the rear chassis wiring harness connector. Remove the engine hood wire harness clamp (2) from the fan guard.

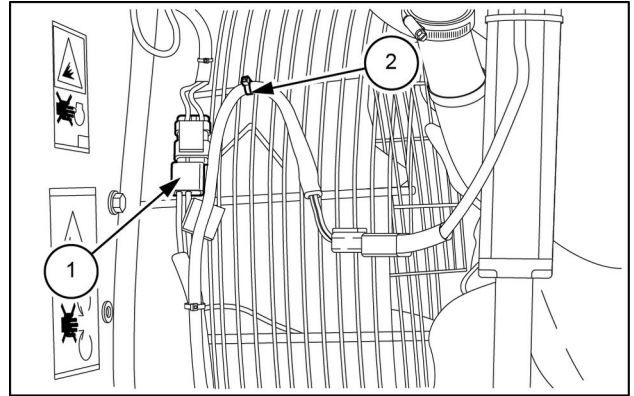

LEIL13WHL0150AB 16

17. Have another person to balance the hood and LOOSEN the hood hinge mounting bolts (see the arrows in figure) from the cooler frame.

NOTE: do not remove the engine hood hinge mounting bolts at this time.

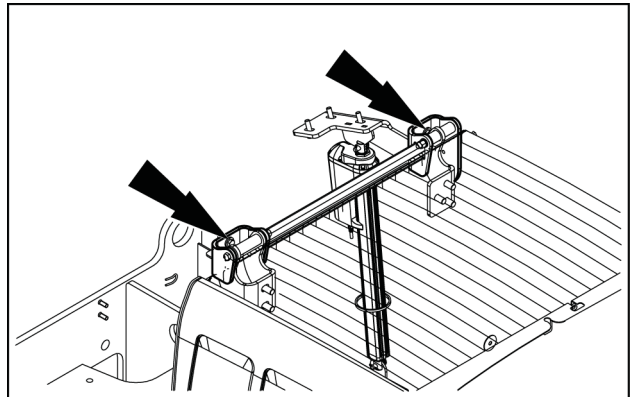

LEIL14WHL0401AB 17

18. Disconnect the wiring harness (5). Put the timed disconnect switch in the ON position. Retract the lifting motor cylinder (1) and remove the clevis pin (3) and the cotter pin (4) from the bottom of the lifting motor cylinder (1). Separate the lifting motor cylinder (1) from the hood support strut (2).

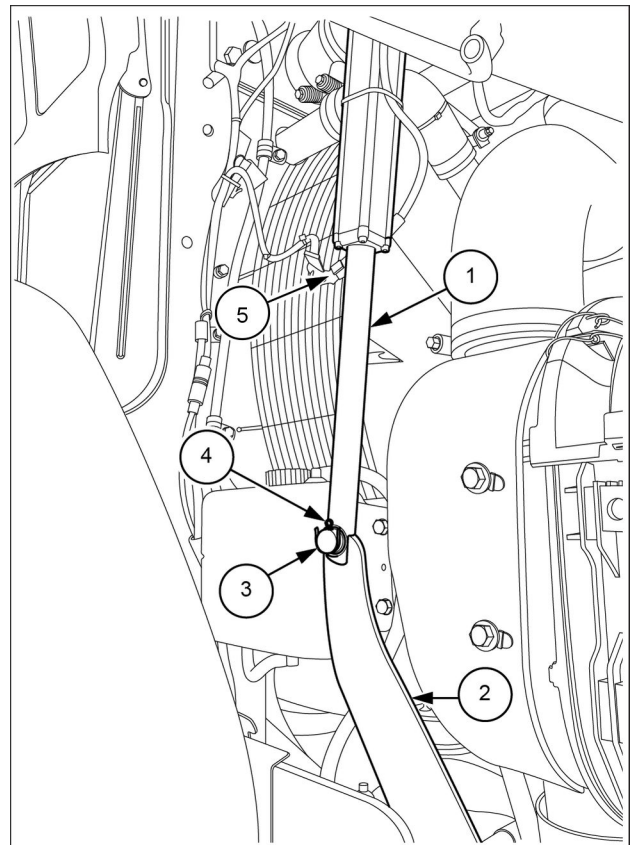

LEIL16WHL1837BB 18

19. Put the timed disconnect switch (1) in OFF position. Remove the battery cover and disconnect ground lead from the batteries (2).

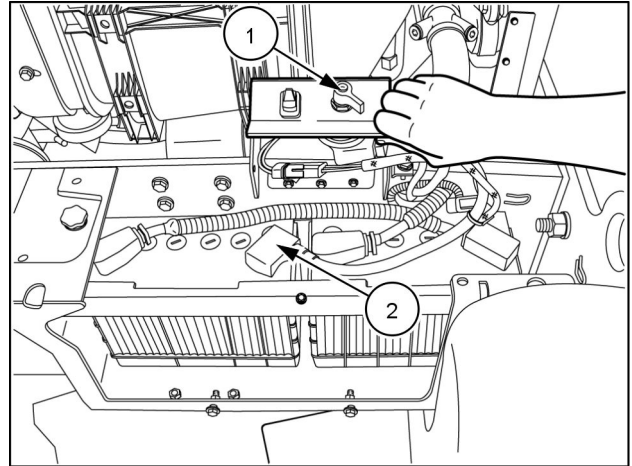

RAPH12WEL0608AA 19

20. Have another person to balance the hood and remove the hood hinge mounting bolts (see the arrows in figure) from the cooler frame.

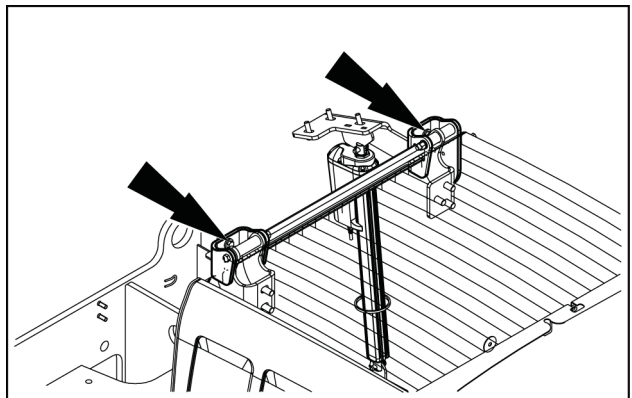

LEIL14WHL0401AB 20

21. Carefully raise and remove the engine hood from the machine. Lower the engine hood onto a suitable platform and disconnect lifting equipment from the exhaust stack (1).

NOTE: radiator overflow hose may interfere with left-hand hood hinge movement and hood removal.

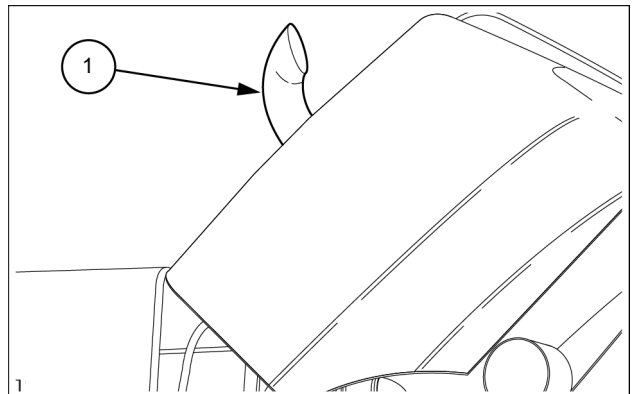

LEIL14WHL0400AB 21

22. Tag and disconnect the engine wiring harness connector from the air filter restriction switch.

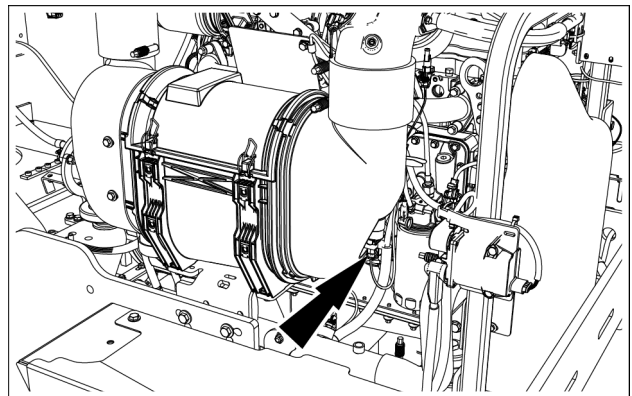

LEIL16WHL0573AB 22

23. Tag and disconnect the engine wiring harness connector from the air inlet humidity sensor (1).

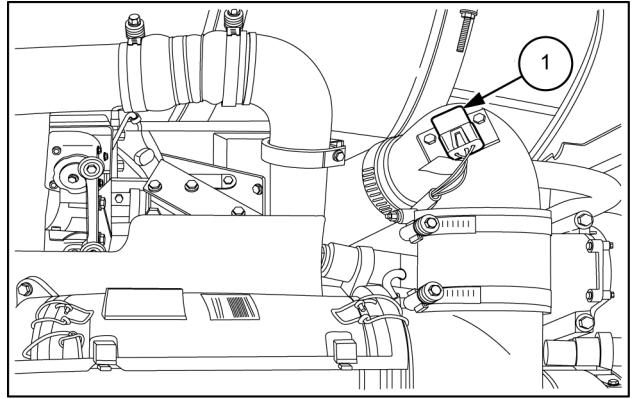

LEIL13WHL0143AB 23

24. Loosen the clamp (1) on the crankcase ventilation hose (2) and disconnect the hose.

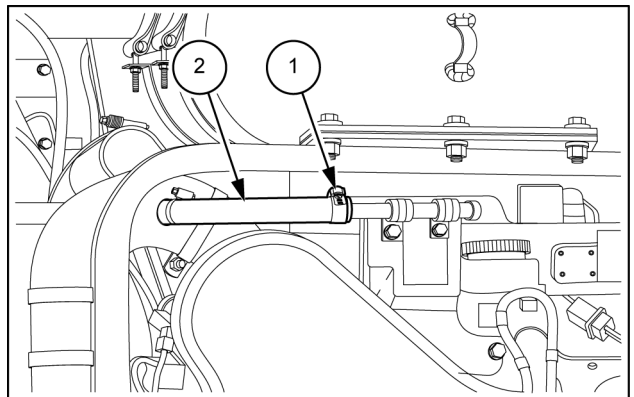

LEIL13WHL0144AB 24

25. Loosen the clamps on the turbocharger and air filter housing. Remove the intake air hose (1). Cover the turbocharger inlet to prevent debris entry.

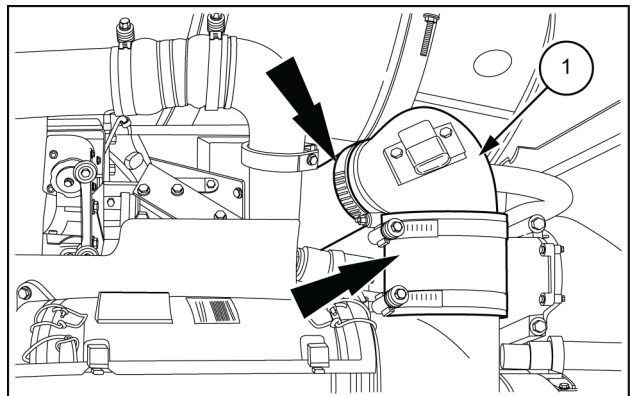

LEIL13WHL0145AB 25

26. Loosen the clamp from the elbow connected to the turbocharger.

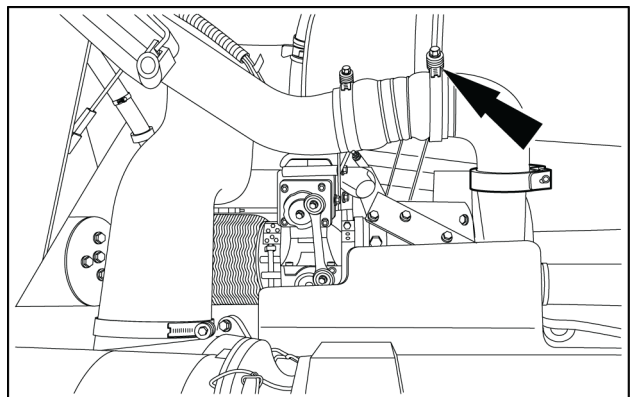

LEIL14WHL0203AB 26

27. Loosen the clamp on the hose at the after cooler inlet and remove the tube.

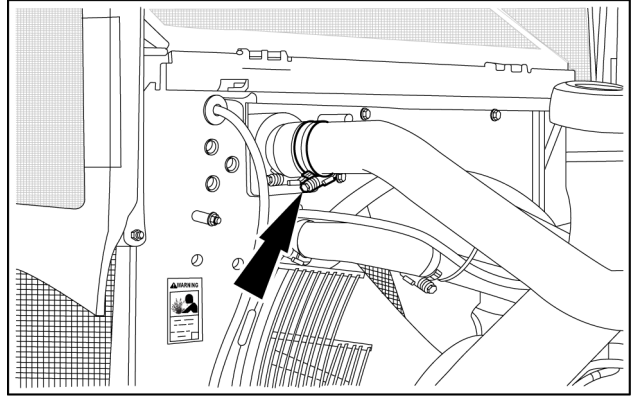

LEIL13WHL0147AB 27

28. Loosen the clamp on the air inlet hose at the air filter housing.

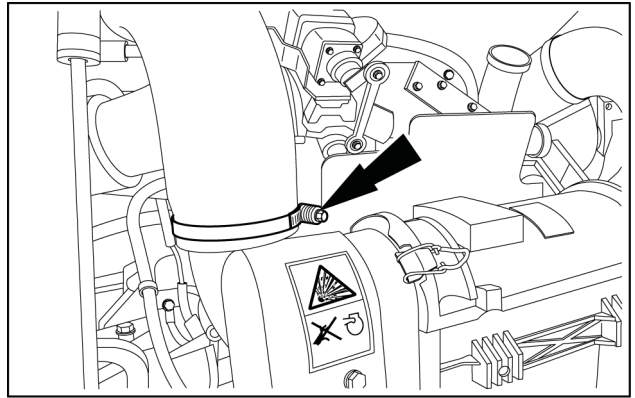

LEIL13WHL0148AB 28

29. Loosen the clamp (1) on the air inlet hose (2) at the exhaust support bracket. Remove the air inlet hose (2).

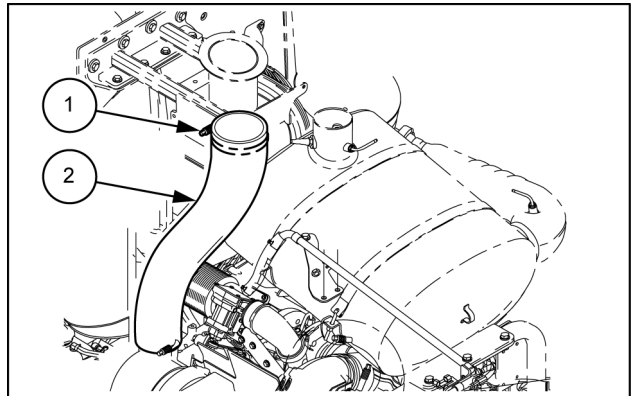

LEIL13WHL0151AB 29

30. Remove the securing bolts (1) with the related washers and nuts. Remove the bracket (2) with the air filter (3) as an assembly.

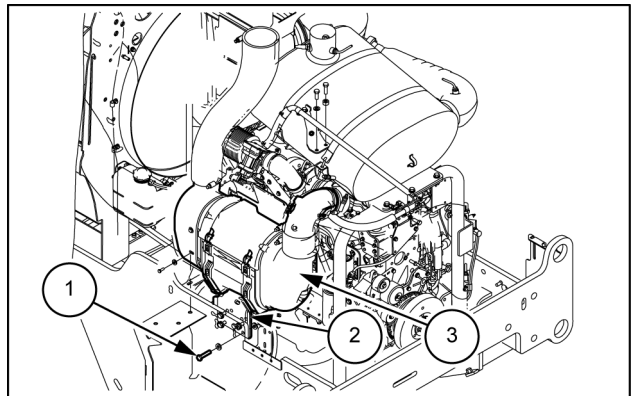

LEIL15WHL0037AB 30

31. Remove the four mounting bolts from the belt cover. Then remove the cover.

NOTE: after removing the belt cover, remove the cover mounting bracket from the left rear side of machine frame.

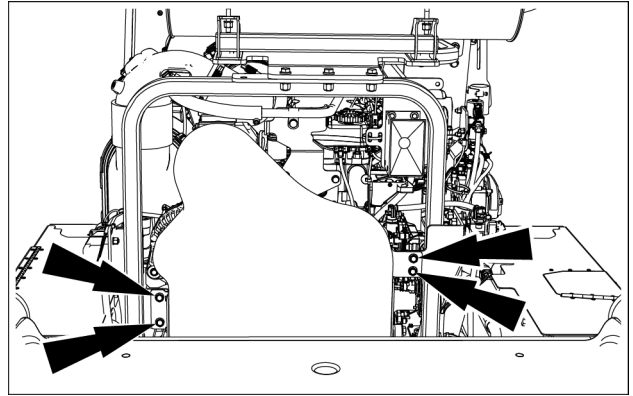

LEIL16WHL1877AB 31

32. Remove the drive belt from the engine.

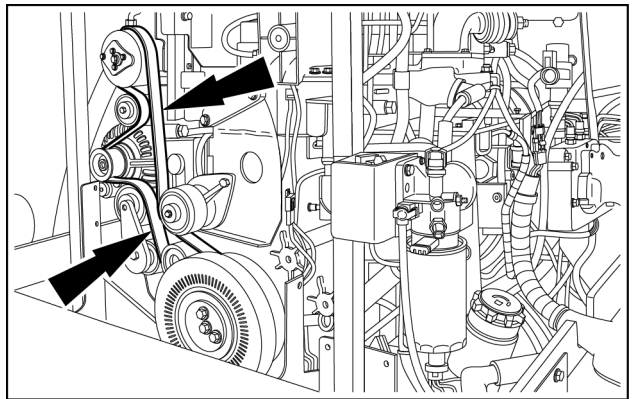

LEIL13WHL0155AB 32

33. If machine is equipped with the air conditioning system, identify, tag, and disconnect the engine wiring harness connectors from the air compressor clutch connector (1) and high pressure switch (2). Then remove the three mounting bolts (3) for the compressor and carefully set it on the left battery cover.

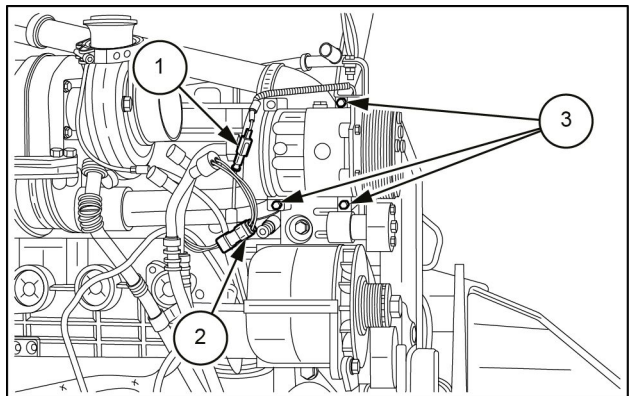

LEIL13WHL0156AB 33

34. Tag and disconnect the wiring from the alternator.

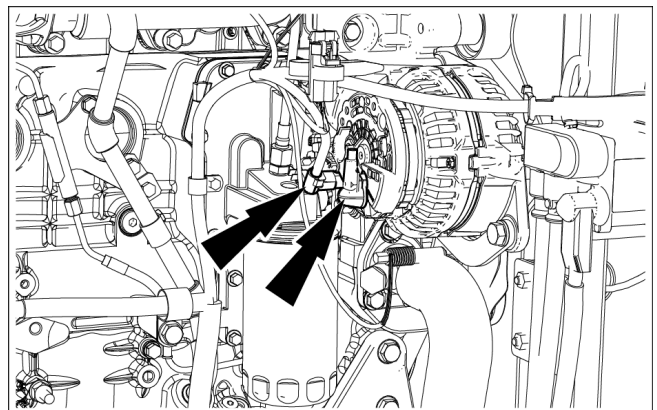

LEIL16WHL0693AB 34

35. Remove the return line of the SCR coolant.

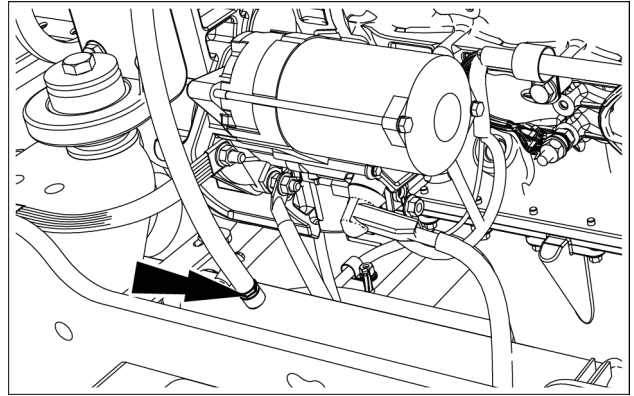

LEIL16WHL0568AB 35

36. Tag and remove the wires from the starter solenoid (1), the ground cable (2), and ground strap (3) from the starter.

NOTE: move the starter cables away from the engine.

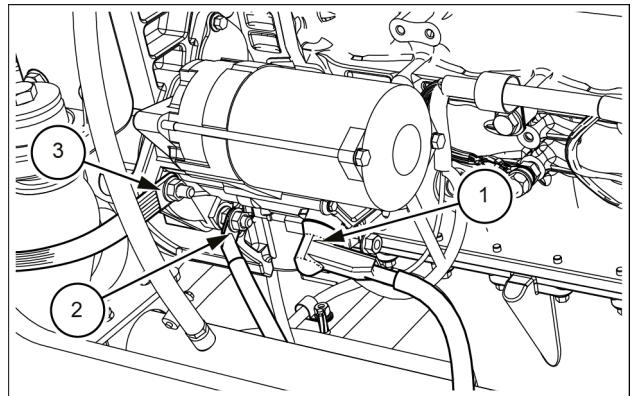

LEIL16WHL0569AB 36

37. Remove the bolts securing the wiring harness clamps to the engine.

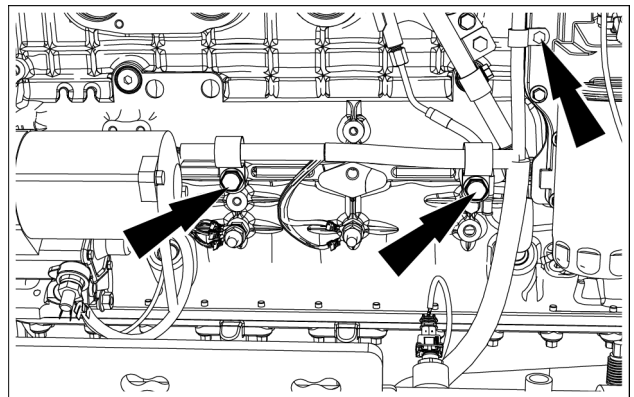

LEIL16WHL0570AB 37

38. Remove the ground wires from the engine.

NOTE: move the wiring harness away from the engine.

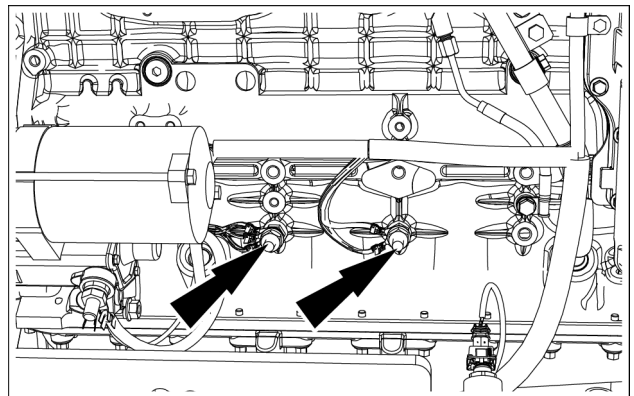

LEIL16WHL0572AB 38

39. If the machine is so equipped, unplug the engine block heater and set it aside.

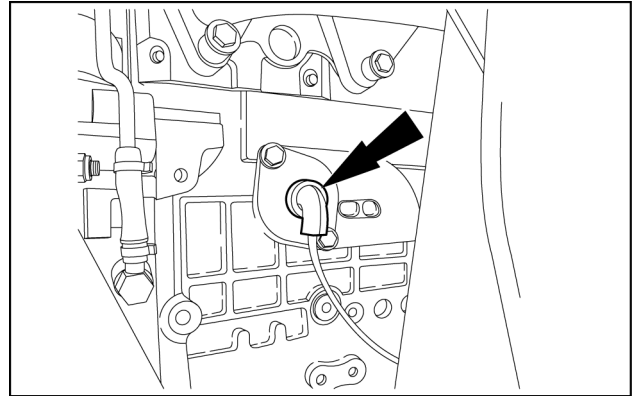

LEIL15WHL0016AB 39

40. Loosen the clamp (see the arrow in figure) and disconnect the pipe.

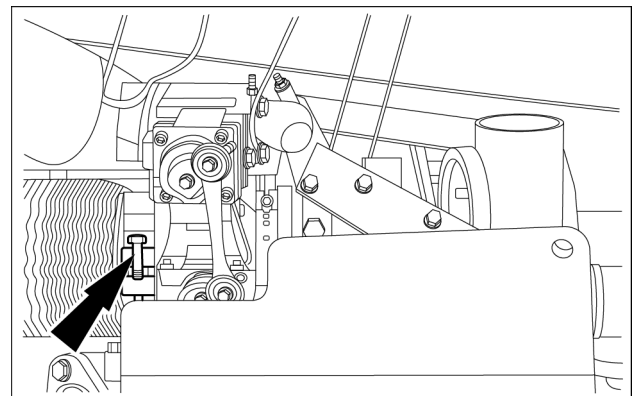

LEIL15WHL0015AB 40

41. Loosen the clamps and remove the lower coolant hose from the engine.

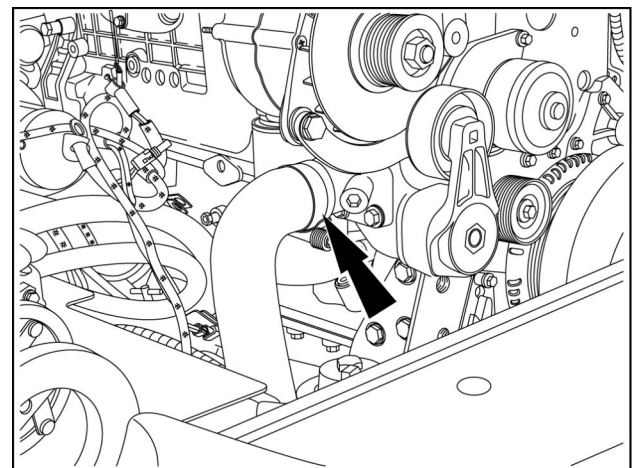

RAPH12WEL0629AA 41

42. Remove the radiator hose from the engine.

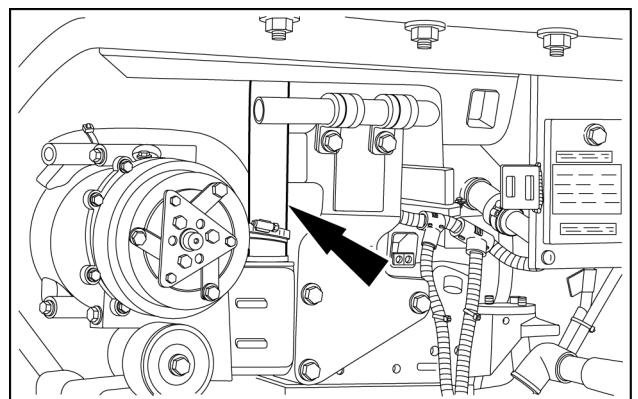

LEIL13WHL0159AB 42

43. Remove the return radiator hose (1) and the engine coolant vent hose from the top of the radiator.

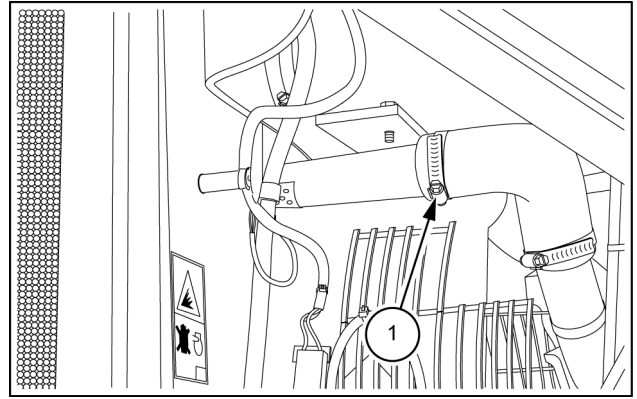

LEIL13WHL0141AB 43

44. Remove the overflow tank of the engine coolant.

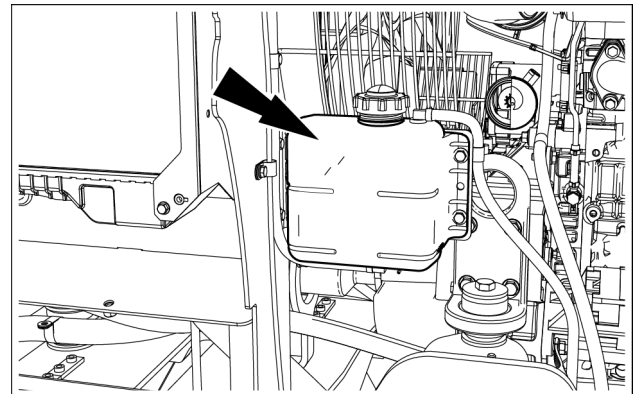

LEIL16WHL0574AB 44

45. Remove the bracket of the overflow tank.

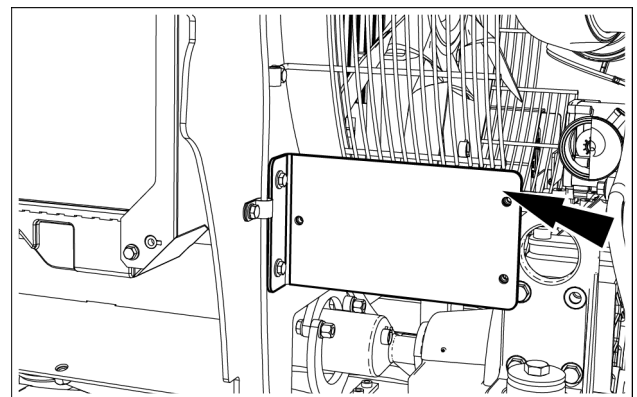

LEIL16WHL0575AB 45

46. Remove the cooling fan guard.

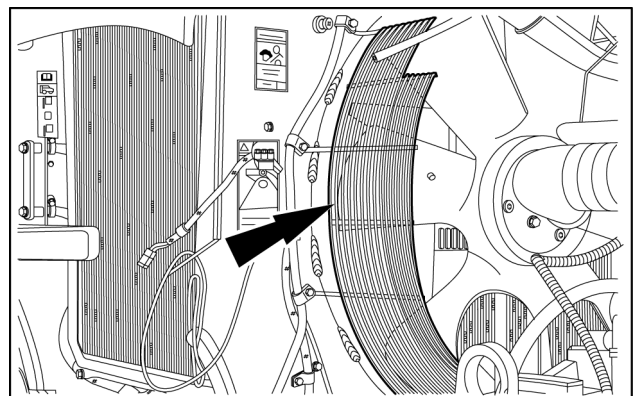

LEIL13WHL0160AB 46

47. Loosen the clamp **(1)** on the intake manifold for the output hose of the after cooler. Loosen the clamp **(2)** from the body of the DEF/AdBlue® tank vent filter.

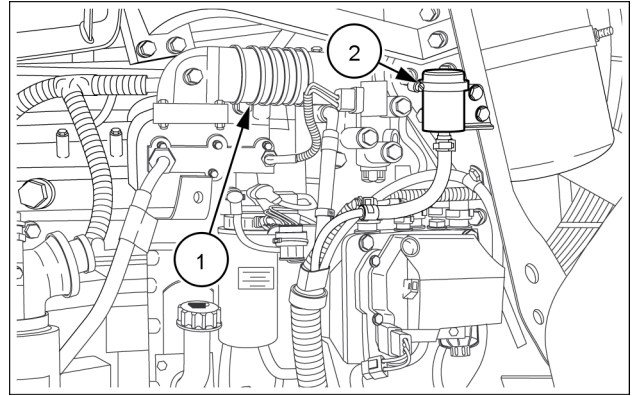

LEIL13WHL0613AA 47

48. Loosen the clamp on the after cooler, and remove the output hose of the after cooler from the machine.

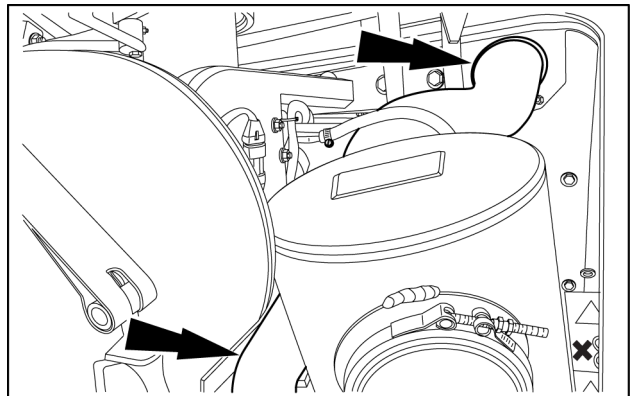

LEIL13WHL0162AB 48

49. Tag and disconnect the fuel filter heater wire **(1)** and the water sensor **(2)**. Then drain fuel filter and disconnect the inlet **(3)** and outlet **(4)** fuel lines from the fuel filter head. Plug the lines and cap the fittings. Remove the ground wire and the attachment bolt **(5)** of the fuel filter head.

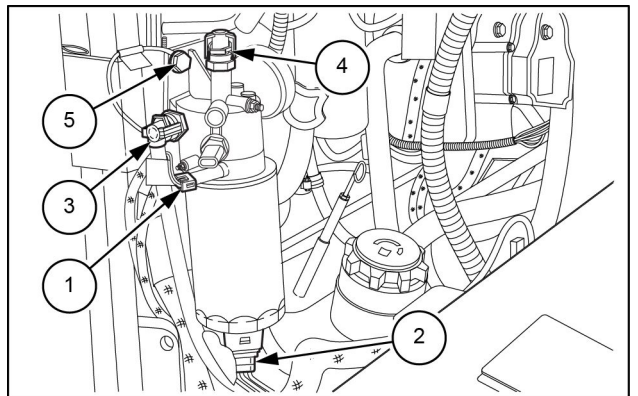

LEIL13WHL0163AB 49

50. Tag and remove the grid heater cable **(1)**.
NOTE: hold the rear nut with a second wrench to prevent grid heater damage.

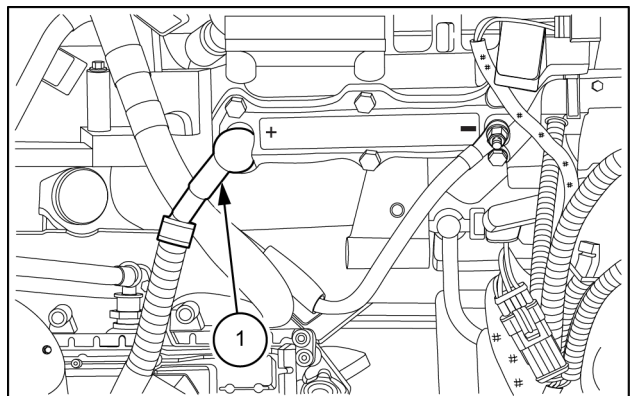

LEIL13WHL0164AB 50



Suggest:

If the above button click is invalid.

Please download this document

first, and then click the above link

to download the complete manual.

Thank you so much for reading

51. Remove wire harness support clamp.

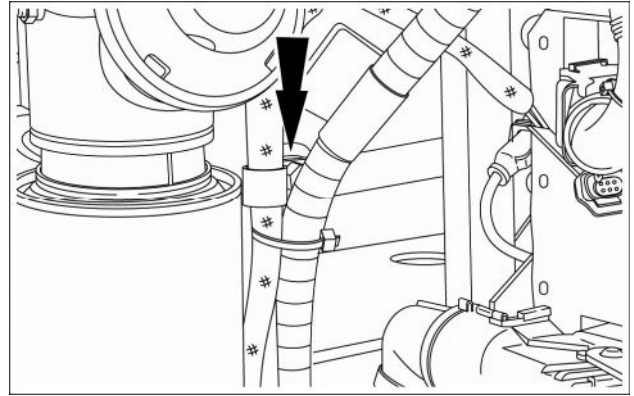

LEIL16WHL0490AB 51

52. Remove the P-clamp and cut the cable ties by the supply module. Disconnect the end of the jumper harness (near the supply module) from the Diesel Oxidation Catalyst (DOC) support.

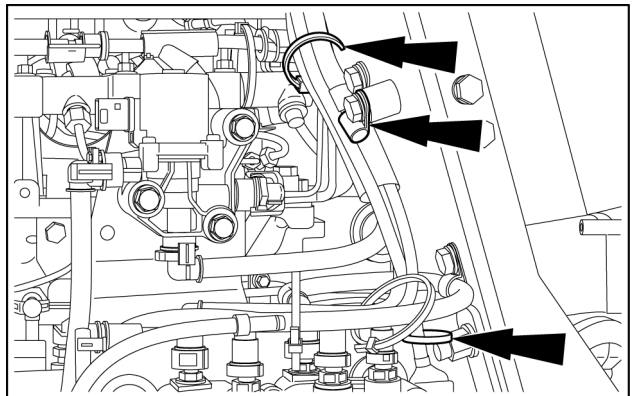

LEIL15WHL0034AB 52

53. Loosen the clamp (1) on the Diesel Oxidation Catalyst (DOC).

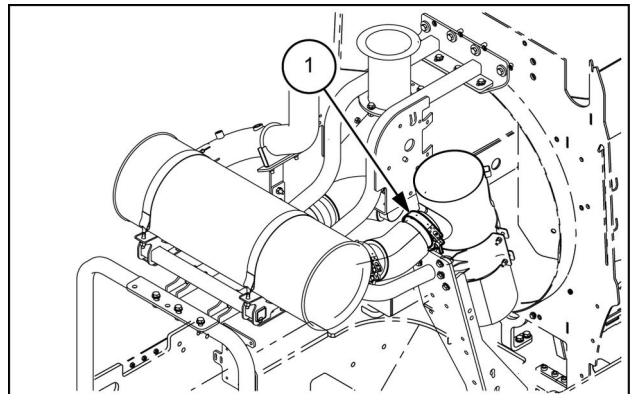

LEIL14WHL0402AB 53

54. Tag and disconnect the connector (1).

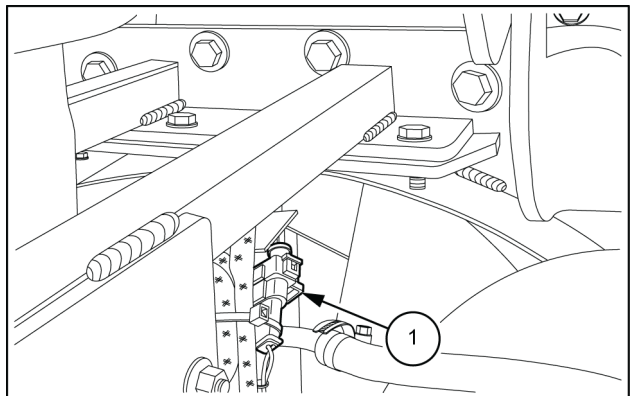

LEIL13WHL0167AB 54

<https://www.ebooklibonline.com>

Hello dear friend!

Thank you very much for reading.

Enter the link into your browser.

The full manual is available for immediate download.

<https://www.ebooklibonline.com>