

**580ST
590ST
695ST
Stage IIIB
Tractor Backhoe Loader**

SERVICE MANUAL

Part number 47847146

English

June 2015

Replaces part number 84568047A

© 2015 CNH Industrial America LLC. All Rights Reserved.

CASE
CONSTRUCTION



SERVICE MANUAL

**580ST T4
590ST T4
695ST T4**

Link Product / Engine

Product	Market Product	Engine
580ST T4	Europe	F5HFL413C*A001
590ST T4	Europe	F5HFL413B*A002
695ST T4	Europe	F5HFL413B*A002

<https://www.ebooklibonline.com>

Hello dear friend!

Thank you very much for reading.

Enter the link into your browser.

The full manual is available for immediate download.

<https://www.ebooklibonline.com>

Contents

INTRODUCTION

Machine completion and equipment	05
[05.102] Machine completion	05.1
Engine	10
[10.001] Engine and crankcase	10.1
[10.501] Exhaust Gas Recirculation (EGR) - Diesel Particulate Filter (DPF) exhaust treatment	10.2
[10.400] Engine cooling system	10.3
[10.304] Engine lubrication system	10.4
Transmission	21
[21.112] Power shuttle transmission	21.1
[21.134] Power shuttle transmission external controls	21.2
[21.104] Power shuttle transmission lubrication system	21.3
[21.154] Power shuttle transmission internal components	21.4
[21.113] Powershift transmission	21.5
[21.135] Powershift transmission external controls	21.6
[21.105] Powershift transmission lubrication system	21.7
[21.155] Powershift transmission internal components	21.8
[21.145] Gearbox internal components	21.9
Four-Wheel Drive (4WD) system	23
[23.314] Drive shaft	23.1
Front axle system	25
[25.100] Powered front axle	25.1
[25.102] Front bevel gear set and differential	25.2
[25.108] Final drive hub, steering knuckles, and shafts	25.3
Rear axle system	27

[27.100] Powered rear axle.....	27.1
[27.106] Rear bevel gear set and differential.....	27.2
[27.120] Planetary and final drives	27.3
Brakes and controls	33
[33.202] Hydraulic service brakes	33.1
[33.110] Parking brake or parking lock	33.2
Hydraulic systems.....	35
[35.000] Hydraulic systems.....	35.1
[35.300] Reservoir, cooler, and filters.....	35.2
[35.104] Fixed displacement pump.....	35.3
[35.106] Variable displacement pump	35.4
[35.102] Pump control valves.....	35.5
[35.350] Safety and main relief valves	35.6
[35.128] Auxiliary hydraulic function control	35.7
[35.355] Hydraulic hand control	35.8
[35.352] Hydraulic swing system	35.9
[35.724] Front loader hydraulic system control.....	35.10
[35.701] Front loader arm hydraulic system	35.11
[35.723] Front loader bucket hydraulic system	35.12
[35.726] Excavator and backhoe hydraulic controls.....	35.13
[35.736] Boom hydraulic system	35.14
[35.737] Dipper hydraulic system.....	35.15
[35.738] Excavator and backhoe bucket hydraulic system.....	35.16
[35.739] Swing arm hydraulic system	35.17
[35.703] Stabilizer hydraulic system.....	35.18
[35.740] Telescopic arm hydraulic system.....	35.19
Frames and ballasting	39
[39.100] Frame	39.1

[39.140] Ballasts and supports	39.2
Steering.....	41
[41.101] Steering control	41.1
[41.106] Tie rods.....	41.2
[41.200] Hydraulic control components.....	41.3
[41.206] Pump	41.4
[41.216] Cylinders	41.5
Wheels	44
[44.511] Front wheels.....	44.1
[44.520] Rear wheels.....	44.2
Cab climate control	50
[50.100] Heating	50.1
[50.104] Ventilation	50.2
[50.200] Air conditioning.....	50.3
Electrical systems	55
[55.100] Harnesses and connectors.....	55.1
[55.201] Engine starting system	55.2
[55.301] Alternator.....	55.3
[55.302] Battery.....	55.4
[55.011] Fuel tank system	55.5
[55.012] Engine cooling system	55.6
[55.640] Electronic modules	55.7
[55.512] Cab controls.....	55.8
[55.047] Steering control system	55.9
[55.408] Warning indicators, alarms, and instruments	55.10
[55.991] Telematics	55.11
[55.DTC] FAULT CODES.....	55.12
Front loader and bucket.....	82

[82.100] Arm.....	82.1
[82.300] Bucket.....	82.2
Booms, dippers, and buckets	84
[84.114] Boom pivoting support	84.1
[84.910] Boom.....	84.2
[84.912] Dipper arm	84.3
[84.100] Bucket.....	84.4
Platform, cab, bodywork, and decals	90
[90.105] Machine shields and guards	90.1



INTRODUCTION

Foreword - Important notice regarding equipment servicing

All repair and maintenance work listed in this manual must be carried out only by qualified dealership personnel, strictly complying with the instructions given, and using, whenever possible, the special tools.

Anyone who performs repair and maintenance operations without complying with the procedures provided herein shall be responsible for any subsequent damages.

The manufacturer and all the organizations of its distribution chain, including - without limitation - national, regional, or local dealers, reject any responsibility for damages caused by parts and/or components not approved by the manufacturer, including those used for the servicing or repair of the product manufactured or marketed by the manufacturer. In any case, no warranty is given or attributed on the product manufactured or marketed by the manufacturer in case of damages caused by parts and/or components not approved by the manufacturer.

The manufacturer reserves the right to make improvements in design and changes in specifications at any time without notice and without incurring any obligation to install them on units previously sold. Specifications, descriptions, and illustrative material herein are as accurate as known at time of publication but are subject to change without notice.

In case of questions, refer to your CASE CONSTRUCTION Sales and Service Networks.

Safety rules

Personal safety



This is the safety alert symbol. It is used to alert you to potential personal injury hazards. Obey all safety messages that follow this symbol to avoid possible death or injury.

Throughout this manual you will find the signal words DANGER, WARNING, and CAUTION followed by special instructions. These precautions are intended for the personal safety of you and those working with you.

Read and understand all the safety messages in this manual before you operate or service the machine.

 DANGER indicates a hazardous situation that, if not avoided, will result in death or serious injury.

 WARNING indicates a hazardous situation that, if not avoided, could result in death or serious injury.

 CAUTION indicates a hazardous situation that, if not avoided, could result in minor or moderate injury.

FAILURE TO FOLLOW DANGER, WARNING, AND CAUTION MESSAGES COULD RESULT IN DEATH OR SERIOUS INJURY.

Machine safety

NOTICE: Notice indicates a situation that, if not avoided, could result in machine or property damage.

Throughout this manual you will find the signal word Notice followed by special instructions to prevent machine or property damage. The word Notice is used to address practices not related to personal safety.

Information

NOTE: Note indicates additional information that clarifies steps, procedures, or other information in this manual.

Throughout this manual you will find the word Note followed by additional information about a step, procedure, or other information in the manual. The word Note is not intended to address personal safety or property damage.

Safety rules

General safety rules

Use caution when you operate the machine on slopes. Raised equipment, full tanks and other loads will change the center of gravity of the machine. The machine can tip or roll over when near ditches and embankments or uneven surfaces.

Never permit anyone other than the operator to ride on the machine.

Never operate the machine under the influence of alcohol or drugs, or while you are otherwise impaired.

When digging or using ground-engaging attachments, be aware of buried cables. Contact local utilities to determine the locations of services.

Pay attention to overhead power lines and hanging obstacles. High voltage lines may require significant clearance for safety.

Hydraulic oil or diesel fuel leaking under pressure can penetrate the skin, causing serious injury or infection.

- DO NOT use your hand to check for leaks. Use a piece of cardboard or paper.
- Stop the engine, remove the key, and relieve the pressure before you connect or disconnect fluid lines.
- Make sure that all components are in good condition. Tighten all connections before you start the engine or pressurize the system.
- If hydraulic fluid or diesel fuel penetrates the skin, seek medical attention immediately.
- Continuous long term contact with hydraulic fluid may cause skin cancer. Avoid long term contact and wash the skin promptly with soap and water.

Keep clear of moving parts. Loose clothing, jewelry, watches, long hair, and other loose or hanging items can become entangled in moving parts.

Wear protective equipment when appropriate.

DO NOT attempt to remove material from any part of the machine while it is being operated or while components are in motion.

Make sure that all guards and shields are in good condition and properly installed before you operate the machine. Never operate the machine with shields removed. Always close access doors or panels before you operate the machine.

Dirty or slippery steps, ladders, walkways, and platforms can cause falls. Make sure these surfaces remain clean and clear of debris.

A person or pet within the operating area of a machine can be struck or crushed by the machine or its equipment. DO NOT allow anyone to enter the work area.

Raised equipment and/or loads can fall unexpectedly and crush persons underneath. Never allow anyone to enter the area underneath raised equipment during operation.

Never operate the engine in enclosed spaces as harmful exhaust gases may build up.

Before you start the machine, be sure that all controls are in neutral or park lock position.

Start the engine only from the operator's seat. If you bypass the safety start switch, the engine can start with the transmission in gear. Do not connect or short across terminals on the starter solenoid. Attach jumper cables as described in the manual. Starting in gear may cause death or serious injury.

Always keep windows, mirrors, all lighting, and Slow-Moving Vehicle (SMV) emblem or Speed Identification Symbol (SIS) clean to provide the best possible visibility while you operate the machine.

Operate controls only when seated in the operator's seat, except for those controls expressly intended for use from other locations.



SERVICE MANUAL

Engine

580ST T4

590ST T4

695ST T4

Engine - General specification

Diesel engine

72 kW - 97 Hp HP Engine (580ST)

Specifications (ISO 14396)	72 kW - 97 Hp @ 2200 RPM
Model	F5HFL413C*A
Type	Diesel, electronic
No. of cylinders	4
Valves per cylinder	2
Bore	99 mm (3.90 in)
Stroke	110 mm (4.33 in)
Displacement	4485 cm³ (273.69 in³)
Compression ratio	16.5:1
Maximum torque (EC)	453 N·m (334 lb ft) @ 1400 RPM
Low idle speed at no load	950 - 1050 RPM
High idle speed at no load	2320 - 2440 RPM
Maximum speed at full load	2200 RPM
Air intake	TAA (turbocharged with aftercooler)

Supply

Type	High-pressure, common rail
Injection pump	CP3 high-pressure pump
Control unit	EDC17
Injection sequence	1-3-4-2
Cold-start device	Glow plugs (standard)

Cooling

Pump type	H ₂ O pump
Pump drive	Belt drive
Temperature switch (opening start)	79 - 83 °C (174.2 - 181.4 °F)

82 kW - 110 Hp ENGINE (590ST - 695ST)

Specifications (ISO 14396)

Model (B110C-B110CTC-B115C)

Type	82 kW – 110 Hp @ 2200 RPM F5HFL413B*A
No. of cylinders	Diesel, electronic 4
Valves per cylinder	4
Bore	99 mm (3.9 in)
Stroke	110 mm (4.33 in)
Displacement	4485 cm³ (273.69 in³)
Compression ratio	16.5:1
Maximum torque (EC)	516 N·m (380.58 lb ft) @ 1400 RPM
Low idle speed at no load	950 - 1050 RPM
High idle speed at no load	2320 - 2420 RPM
Maximum speed at full load	2200 RPM
Air intake	TAA (turbocharged with aftercooler)

Supply

Type	High-pressure, common rail
Injection pump	CP3 high-pressure pump
Control unit	EDC17
Injection sequence	1-3-4-2
Cold-start device	“Grid heater” (optional)

Cooling

Pump type	H ₂ O pump
Pump drive	Belt drive
Temperature switch (opening start)	79 - 83 °C (174.2 - 181.4 °F)

Engine - Component localization

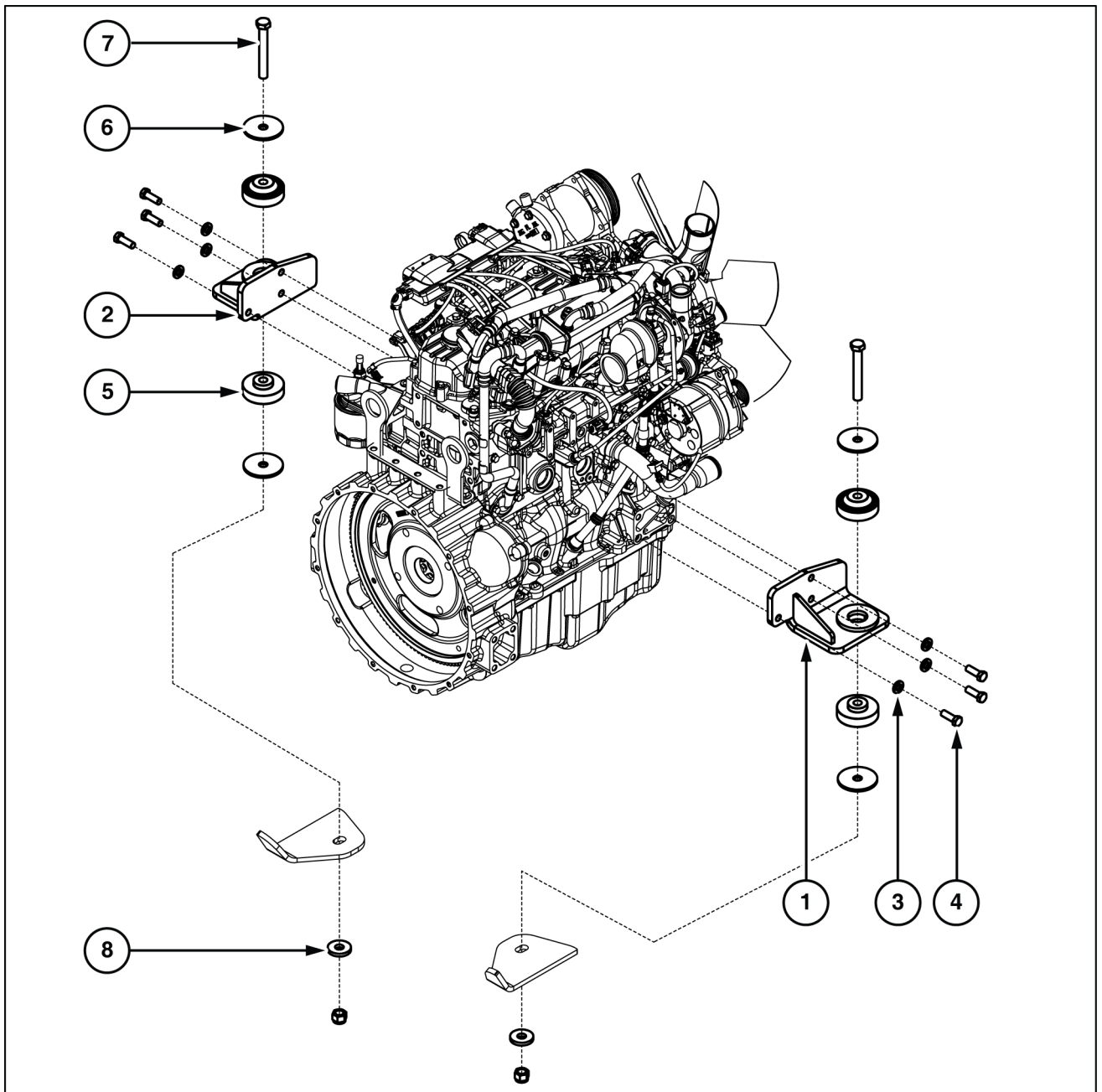

LELI12TLB0087GB 1

1. Bracket RH engine mount
2. Bracket LH engine mount
3. Washer
4. M12 X 35 hex screw
5. Anti-vibration device

6. Washer
7. M16 X 120 hex screw
8. Washer
9. M16 nut
[tightening torque 210 - 240 N·m (155 - 177 lb ft)]

Engine - Prepare for removal

Prior operation:

Position the machine on a flat and compact surface.

Prior operation:

Apply the parking brake and chock the wheels with wedges.

Prior operation:

Use only the recommended tools.

Prior operation:

Do not insert hands or extraneous components between parts.

Prior operation:

Disconnect the battery before proceeding (Refer to **Battery - Disconnect (55.302)**).

Preliminary operations

NOTICE: Do not allow unauthorized persons to repair or service this machine. Be certain to read the Use and Maintenance Manual with care before starting, operating, servicing, refuelling or repairing this machine.

NOTICE: Tag and identify all electrical connections and hydraulic hoses to facilitate easy identification during reinstallation.

1. Turn the Starter switch to the "OFF" position and display the "DO NOT START" warning notice.
2. Unscrew the cap of the hydraulic oil tank slowly to release the air pressure from inside the tank.
3. Move the control lever repeatedly back and forth to release pressure in the hydraulic circuit.
4. With oil warm, remove plug from the bottom of the machine and drain the oil into a receptacle of suitable capacity.

NOTICE: Fluid under pressure; Before removing the plug or cap, turn slowly to release pressure from the system. See the Use and Maintenance Manual.

5. Put a container below radiator drain. Remove radiator cap. Remove cap and drain coolant into container. Install cap after coolant has drained. Install radiator cap.
6. Put a container below engine oil drain. Remove cap and drain oil into container. Install cap after oil has drained.
7. Refer to **Engine hood - Remove (90.105)** and remove the engine hood.
8. Refer to **Radiator - Remove (10.400)** and remove the radiator.

Engine - Remove

1. Prepare the engine for removal as explained in **Engine - Prepare for removal (10.001)**.
2. Remove and disconnect compressor electrical connector X-473 (if present).

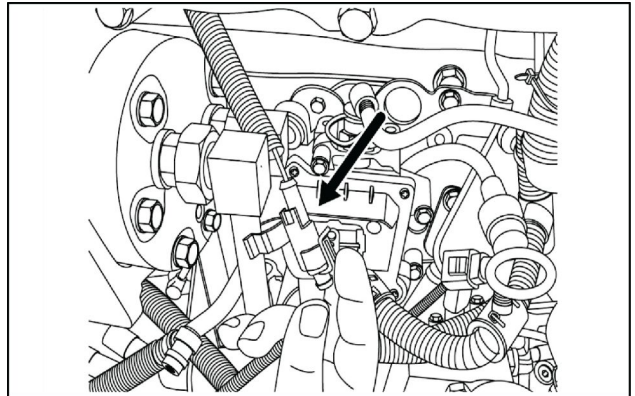

LELI12TLB0038AA 1

3. Identify, tag and disconnect the high pressure and low pressure air conditioning lines, (if present).

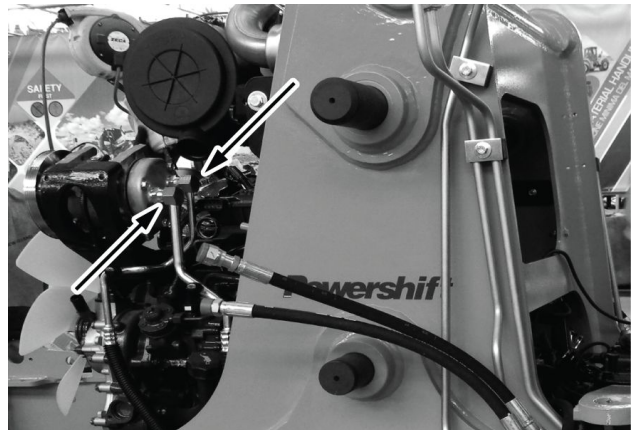

LEPH12TLB0039AA 2

4. Disconnect the air temperature sensor X-474.

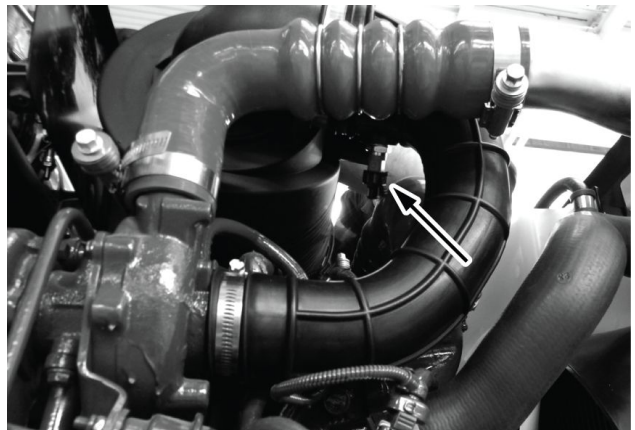

LEPH12TLB0040AA 3

5. Remove the connector X-4 from 2-way air cleaner connector.

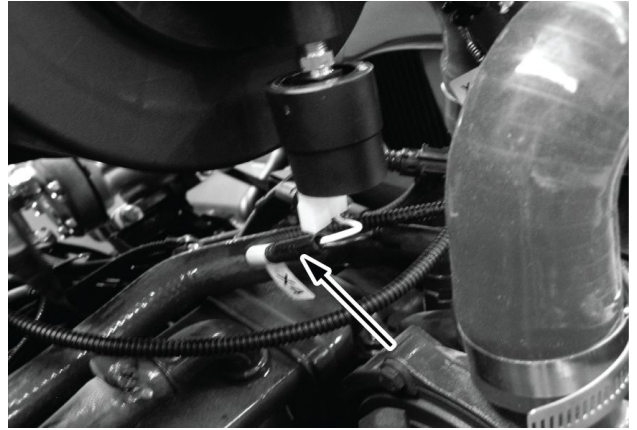

LEPH12TLB0041AA 4

6. Remove the pipe connecting the air cleaner with turbocharger.

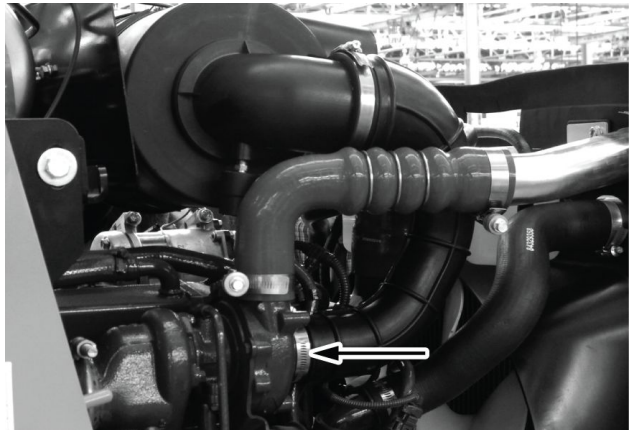

LEPH12TLB0042AA 5

7. Remove the aspirator tube.

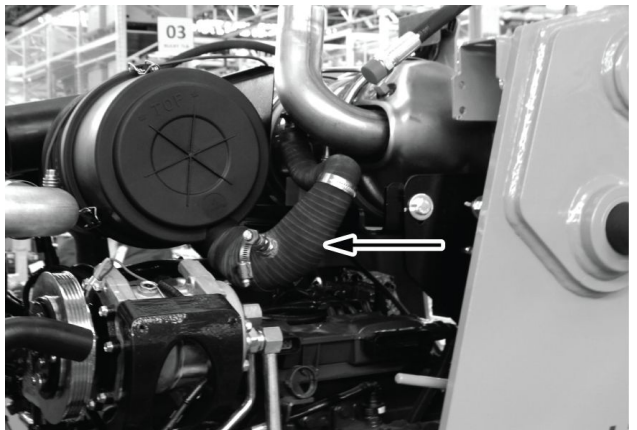

LEPH12TLB0043AA 6

8. Remove the crank case vent.

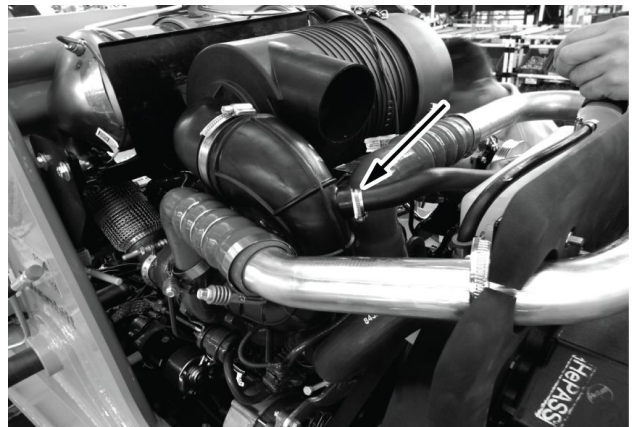

LEPH12TLB0044AA 7

9. Remove the hoses right and left from delta pressure sensor and the connector X-475.

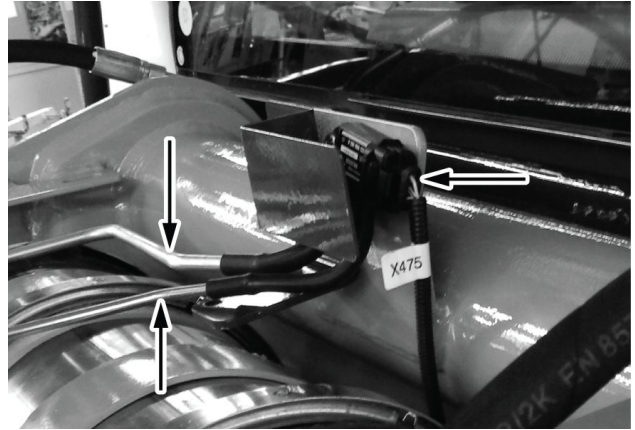

LEPH12TLB0045AA 8

10. Disconnect the connecting exhaust pipe from the turbocharger with a silencer/Diesel Particulate Filter (DPF) opening the clamp.

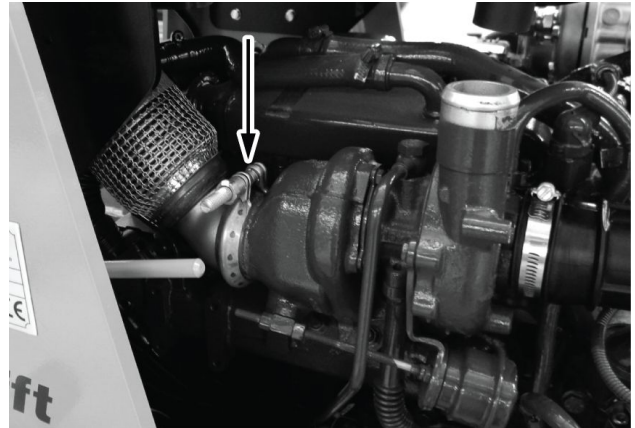

LEPH12TLB0064AA 9

11. Remove the connector X-469 from the electronic module control.

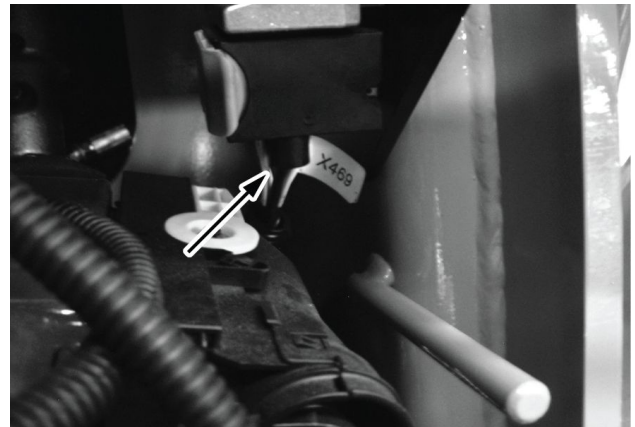

LEPH12TLB0065AA 10

12. Remove the connectors X-470 (1) and X-471 (2) from the engine electronic control unit.

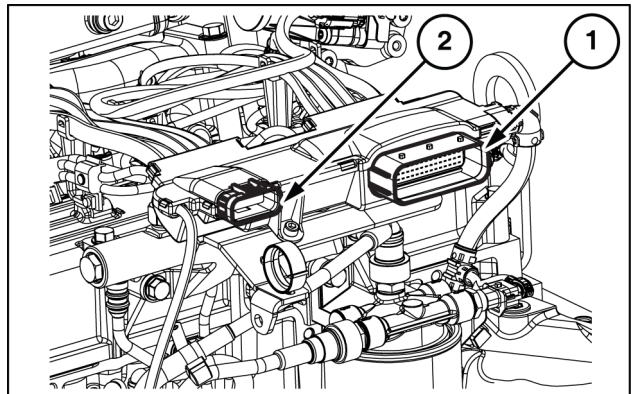

LEPH12TLB0066AB 11

13. Remove the connector X-468.



LEPH12TLB0067AA 12

14. Remove the ground cable and ground strap.

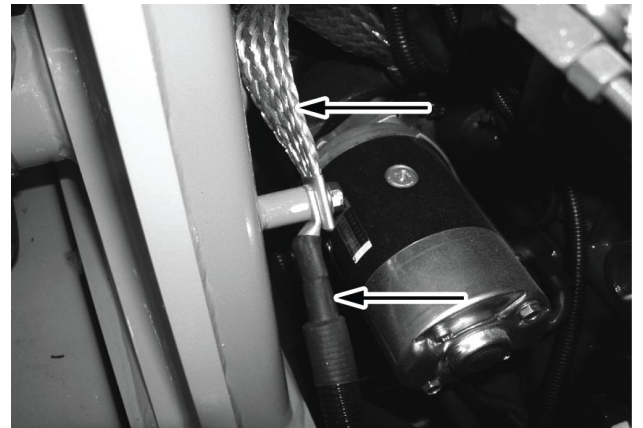

LEPH12TLB0068AA 13

15. Remove the connector X-69.

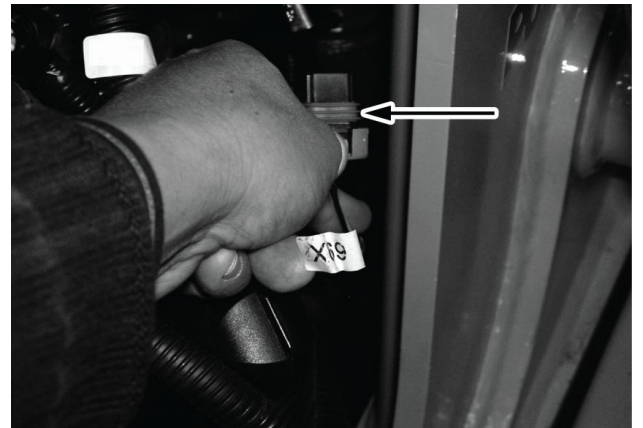

LEPH12TLB0069AA 14

16. Remove the connector X-477 from the DPF temperature sensor.

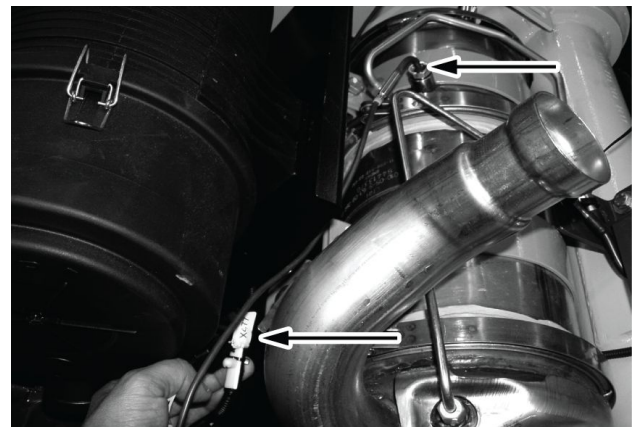

LEPH12TLB0070AA 15

17. Remove the alternator connector X-67 and connector X-10.

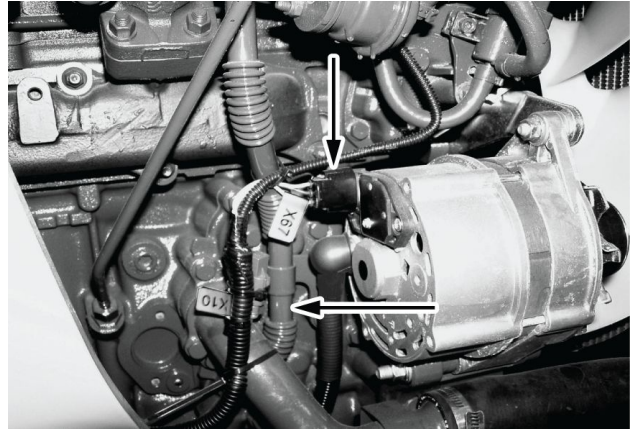

LEPH12TLB0071AA 16

18. Disconnect the connector X-508 from the starter motor and the ignition connector.

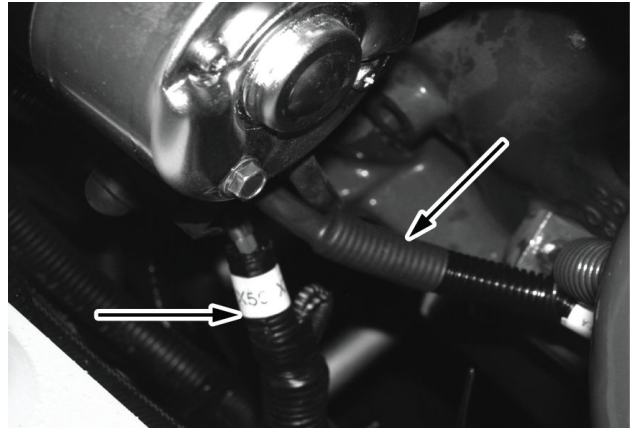

LEPH12TLB0072AA 17

19. Remove the connector X-476 from the DPF temperature sensor.

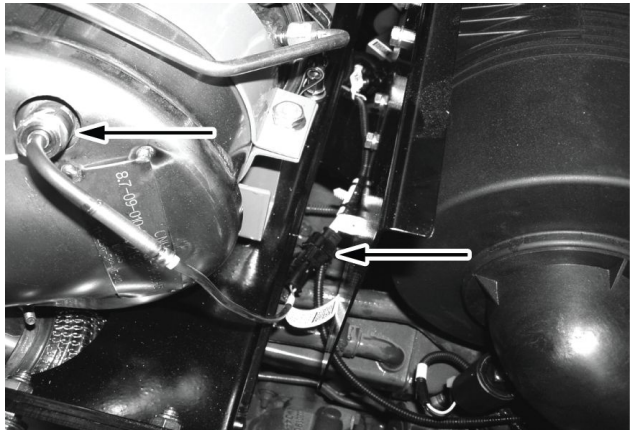

LEPH12TLB0073AA 18

20. Remove the connector from the Lambda sensor.

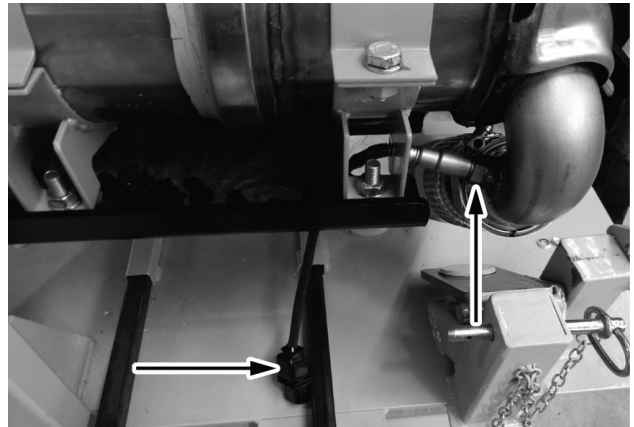

LEPH12TLB0074AA 19

21. Secure the air cleaner/DPF with a lifting device of suitable capacity and remove the screws.

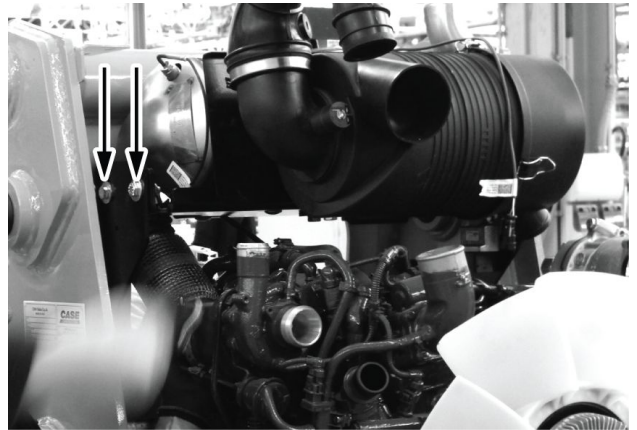

LEPH12TLB0075AA 20

22. Carefully remove the air cleaner/DPF from the frame and place on the support.

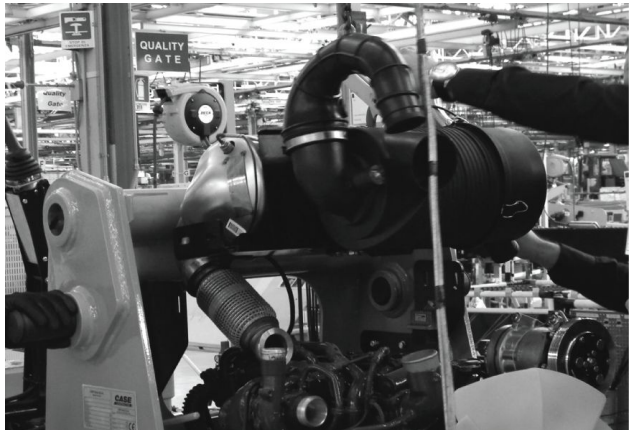

LEPH12TLB0076AA 21

23. Remove the screws that secure the air cleaner support of the DPF.

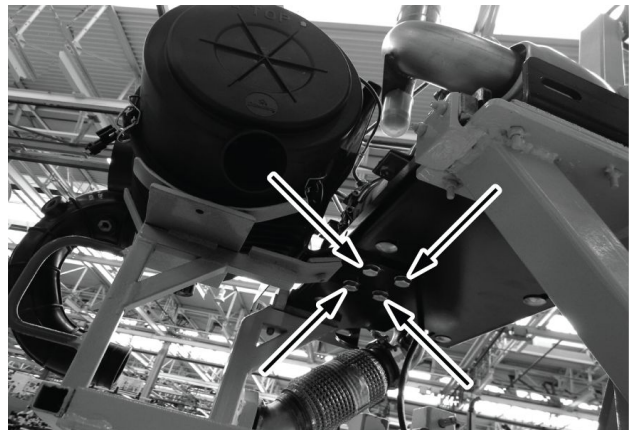

LEPH12TLB0077AA 22

24. Remove the screws that secure the air cleaner to the support plate. Remove the air cleaner from the support.

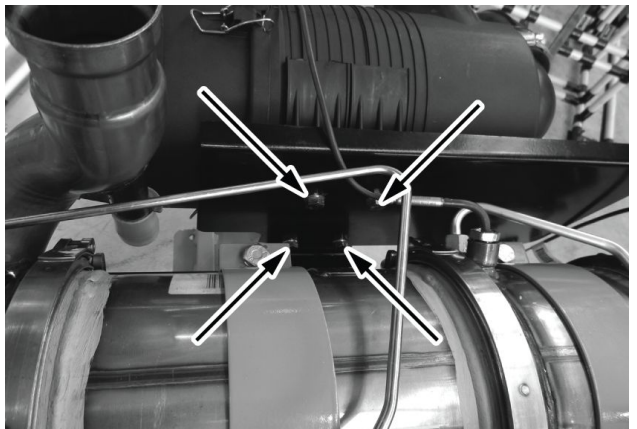

LEPH12TLB0078AA 23

25. Remove the silencer/DPF from its mounting by removing the screws (1) securing the two half flanges (2).

NOTICE: Measure and record the distances "A", "B" and "C" as shown in the Figure in order to ensure a precise connection between the component pipes during reassembly.

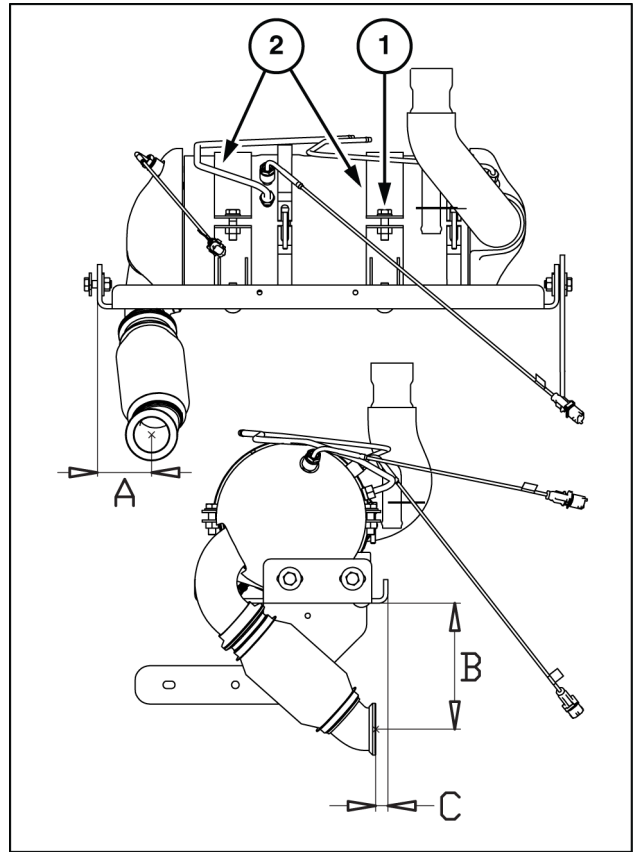

LEL112TLB0079BB 24

26. Remove the flywheel access cover.

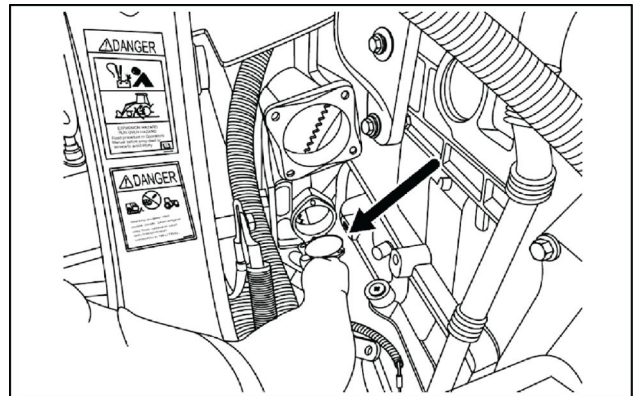

LEL112TLB0080AA 25

27. Use tool **380000988** to rotate the engine to access flywheel flex plate hardware.

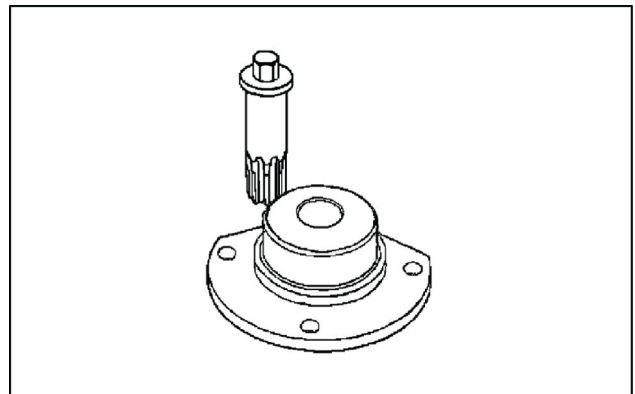

LEL112TLB0081AA 26

28. Remove the flywheel and flex plate hardware.

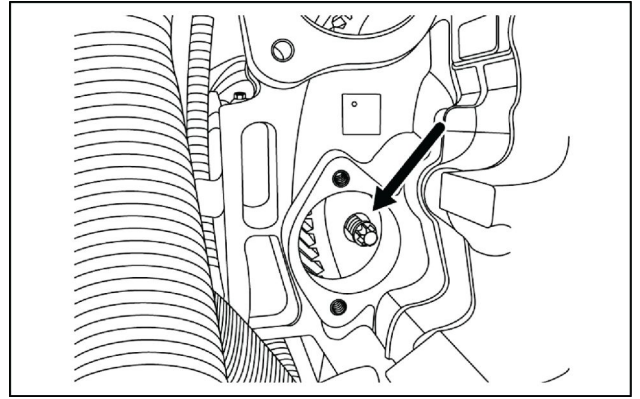

LELI12TLB0082AA 27

29. Attach a suitable lifting device.

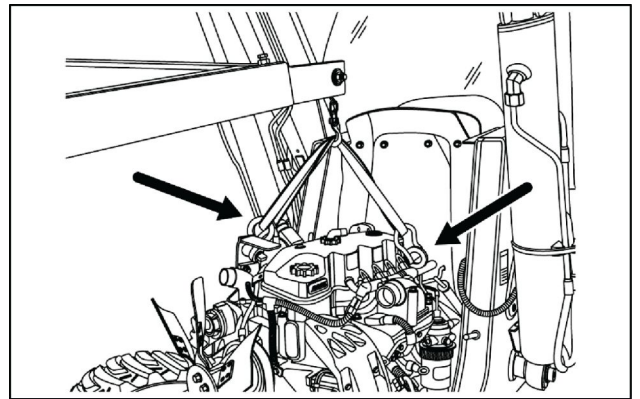

LELI12TLB0083AA 28

30. Remove engine mounting hardware.

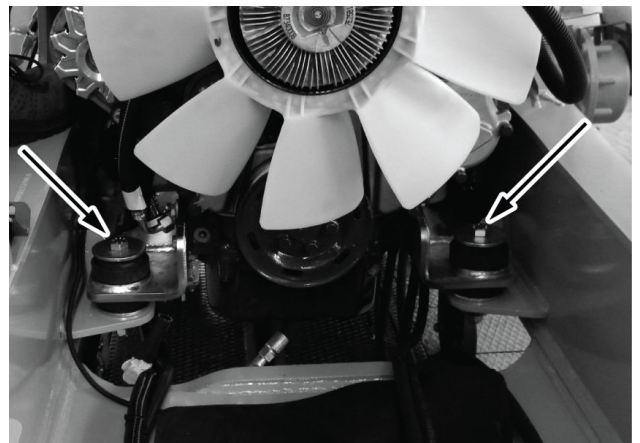

LEPH12TLB0084AA 29

31. Remove hardware which attaches the engine to the transmission.

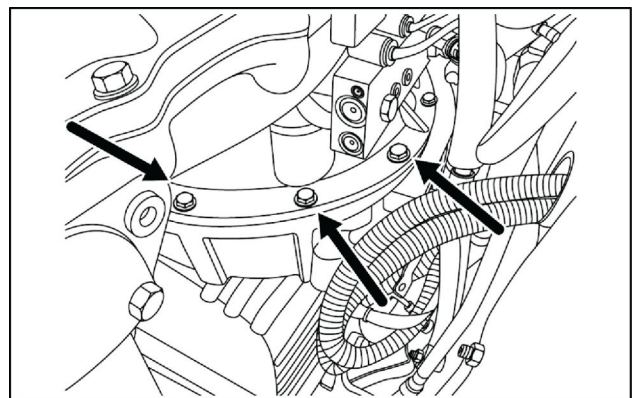

LELI12TLB0085AA 30

32. Make sure that all the harness connectors and hoses have been disconnected and are clear of the engine. Slowly raise the engine from the frame and remove the engine from the machine.

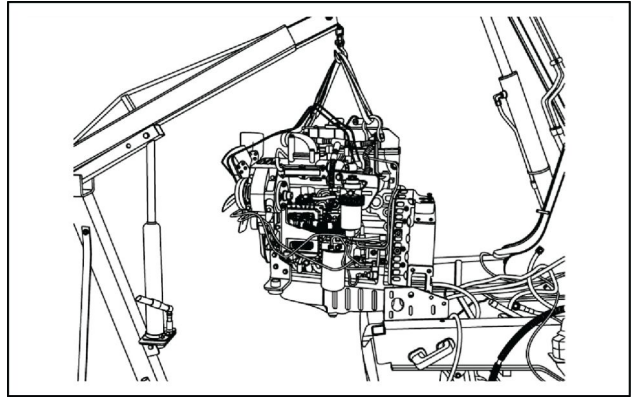

LEL112TLB0086AA 31

Engine - Install

1. Carefully lower the engine on the frame.

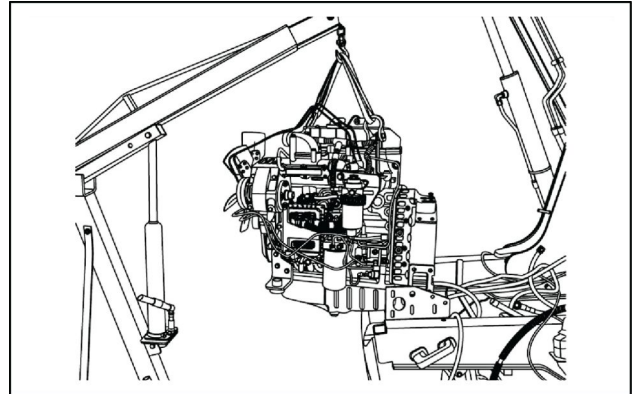

LEL112TLB0086AA 1

2. Attach the engine to the transmission with the hardware removed earlier. Torque the hardware to **52 - 57 N·m (38 - 42 lb ft)**.

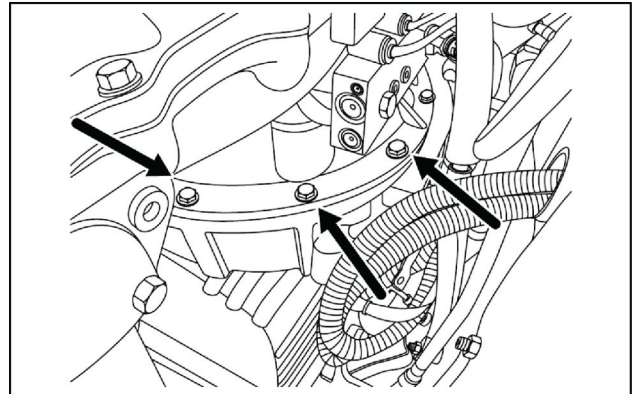

LEL112TLB0089AA 2

3. Install the engine mounting hardware. Torque the hardware to **210 - 240 N·m (155 - 177 lb ft)**.

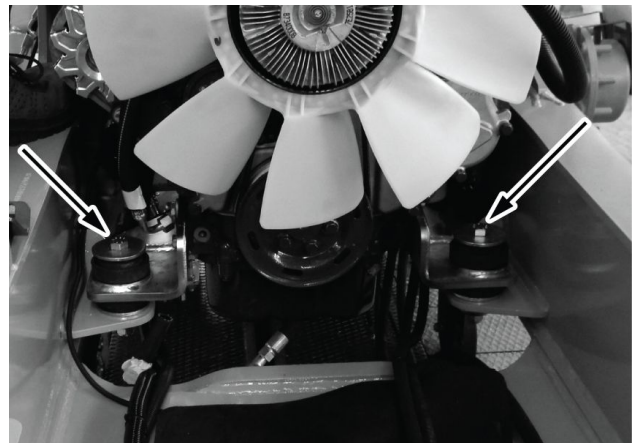

LEPH12TLB0084AA 3

4. Remove the lifting device.

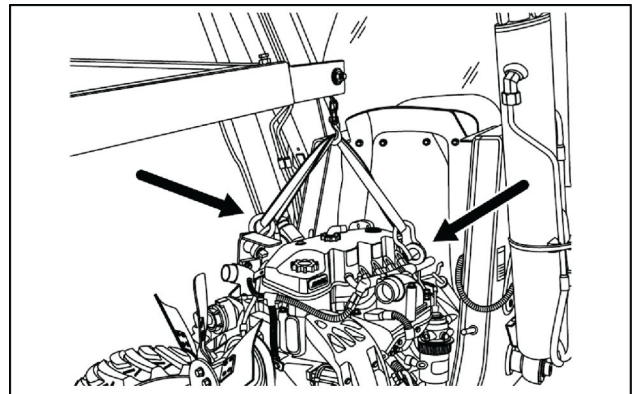

LEL112TLB0091AA 4



Suggest:

If the above button click is invalid.

Please download this document

first, and then click the above link

to download the complete manual.

Thank you so much for reading

5. Rotate the engine to access flywheel. Use tool **38000988**.

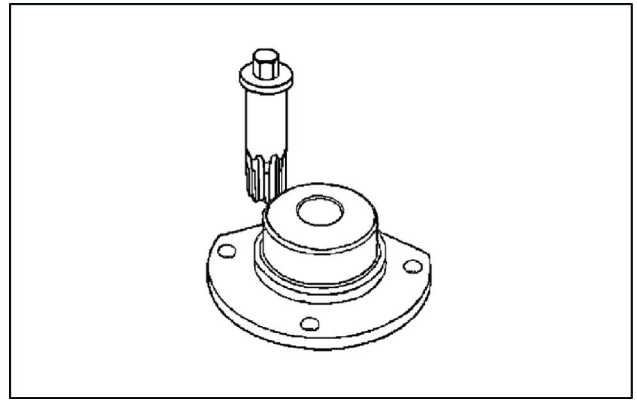

LEL12TLB0081AA 5

6. Reinstall the flywheel and flex plate hardware. Torque to **52 - 57 N·m (38 - 42 lb ft)**.

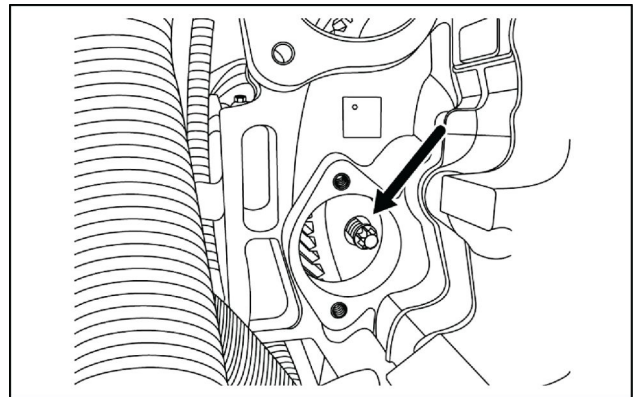

LEL12TLB0082AA 6

7. Install the flywheel access cover.

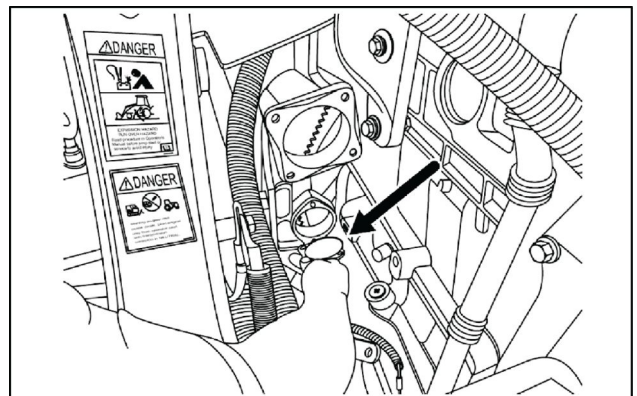

LEL12TLB0080AA 7

<https://www.ebooklibonline.com>

Hello dear friend!

Thank you very much for reading.

Enter the link into your browser.

The full manual is available for immediate download.

<https://www.ebooklibonline.com>