

**580N EP**  
**Tier 4B (final)**  
Tractor Loader Backhoe  
*PIN NHC740227 and above*

**SERVICE MANUAL**

**Part number 48194542**  
1<sup>st</sup> edition English  
November 2017





## **SERVICE MANUAL**

**580N EP Four-Wheel Drive (4WD) Tier 4B (final) [NHC740227 - ]**  
**580N EP Two-Wheel Drive (2WD) Tier 4B (final) [NHC740227 - ]**

# Link Product / Engine

---

<b>Product</b>	<b>Market Product</b>	<b>Engine</b>
580N EP Two-Wheel Drive (2WD) Tier 4B (final) [NHC740227 - ]	North America	F5HFL463D*F005
580N EP Four-Wheel Drive (4WD) Tier 4B (final) [NHC740227 - ]	North America	F5HFL463D*F005

**<https://www.ebooklibonline.com>**

Hello dear friend!

Thank you very much for reading.

Enter the link into your browser.

The full manual is available for immediate download.

**<https://www.ebooklibonline.com>**

# Contents

---

## INTRODUCTION

<b>Engine.....</b>	<b>10</b>
[10.001] Engine and crankcase .....	10.1
[10.103] Crankshaft and flywheel.....	10.2
[10.202] Air cleaners and lines .....	10.3
[10.206] Fuel filters .....	10.4
[10.216] Fuel tanks .....	10.5
[10.218] Fuel injection system.....	10.6
[10.304] Engine lubrication system.....	10.7
[10.400] Engine cooling system .....	10.8
[10.414] Fan and drive .....	10.9
[10.501] Exhaust Gas Recirculation (EGR) exhaust treatment.....	10.10
<b>Transmission.....</b>	<b>21</b>
[21.112] Power shuttle transmission.....	21.1
[21.113] Powershift transmission .....	21.2
[21.134] Power shuttle transmission external controls .....	21.3
[21.135] Powershift transmission external controls.....	21.4
[21.154] Power shuttle transmission internal components .....	21.5
[21.155] Powershift transmission internal components.....	21.6
<b>Front axle system .....</b>	<b>25</b>
[25.100] Powered front axle .....	25.1
[25.102] Front bevel gear set and differential .....	25.2
[25.108] Final drive hub, steering knuckles, and shafts .....	25.3
[25.400] Non-powered front axle .....	25.4
<b>Rear axle system.....</b>	<b>27</b>
[27.100] Powered rear axle.....	27.1

[27.106] Rear bevel gear set and differential .....	27.2
[27.120] Planetary and final drives .....	27.3
<b>Brakes and controls .....</b>	<b>33</b>
[33.110] Parking brake or parking lock .....	33.1
[33.202] Hydraulic service brakes .....	33.2
<b>Hydraulic systems.....</b>	<b>35</b>
[35.000] Hydraulic systems.....	35.1
[35.102] Pump control valves.....	35.2
[35.104] Fixed displacement pump.....	35.3
[35.204] Remote control valves .....	35.4
[35.300] Reservoir, cooler, and filters.....	35.5
[35.350] Safety and main relief valves .....	35.6
[35.357] Pilot system .....	35.7
[35.359] Main control valve .....	35.8
[35.525] Auxiliary hydraulic valves and lines .....	35.9
[35.701] Front loader arm hydraulic system .....	35.10
[35.703] Stabilizer hydraulic system.....	35.11
[35.723] Front loader bucket hydraulic system .....	35.12
[35.726] Excavator and backhoe hydraulic controls.....	35.13
[35.736] Boom hydraulic system .....	35.14
[35.737] Dipper hydraulic system.....	35.15
[35.738] Excavator and backhoe bucket hydraulic system.....	35.16
[35.739] Swing arm hydraulic system .....	35.17
[35.740] Telescopic arm hydraulic system.....	35.18
<b>Frames and ballasting .....</b>	<b>39</b>
[39.100] Frame .....	39.1
[39.129] Stabilizers .....	39.2
<b>Steering.....</b>	<b>41</b>

[41.101] Steering control .....	41.1
[41.200] Hydraulic control components.....	41.2
[41.216] Cylinders .....	41.3
<b>Wheels .....</b>	<b>44</b>
[44.511] Front wheels.....	44.1
[44.520] Rear wheels .....	44.2
<b>Cab climate control .....</b>	<b>50</b>
[50.100] Heating .....	50.1
[50.200] Air conditioning.....	50.2
<b>Electrical systems .....</b>	<b>55</b>
[55.100] Harnesses and connectors.....	55.1
[55.201] Engine starting system .....	55.2
[55.301] Alternator.....	55.3
[55.302] Battery.....	55.4
[55.404] External lighting .....	55.5
[55.408] Warning indicators, alarms, and instruments .....	55.6
[55.510] Cab or platform harnesses and connectors.....	55.7
[55.640] Electronic modules .....	55.8
[55.991] Telematics .....	55.9
[55.DTC] FAULT CODES.....	55.10
<b>Front loader and bucket.....</b>	<b>82</b>
[82.100] Arm.....	82.1
[82.300] Bucket.....	82.2
<b>Booms, dippers, and buckets .....</b>	<b>84</b>
[84.100] Bucket.....	84.1
[84.114] Boom pivoting support .....	84.2
[84.910] Boom .....	84.3
[84.912] Dipper arm .....	84.4

Platform, cab, bodywork, and decals .....	90
[90.100] Engine hood and panels .....	90.1
[90.114] Operator protections .....	90.2
[90.124] Pneumatically-adjusted operator seat.....	90.3
[90.150] Cab .....	90.4
[90.151] Cab interior.....	90.5
[90.154] Cab doors and hatches .....	90.6
[90.156] Cab windshield and windows .....	90.7



## INTRODUCTION

---

## **Foreword - Important notice regarding equipment servicing**

All repair and maintenance work listed in this manual must be carried out only by qualified dealership personnel, strictly complying with the instructions given, and using, whenever possible, the special tools.

Anyone who performs repair and maintenance operations without complying with the procedures provided herein shall be responsible for any subsequent damages.

The manufacturer and all the organizations of its distribution chain, including - without limitation - national, regional, or local dealers, reject any responsibility for damages caused by parts and/or components not approved by the manufacturer, including those used for the servicing or repair of the product manufactured or marketed by the manufacturer. In any case, no warranty is given or attributed on the product manufactured or marketed by the manufacturer in case of damages caused by parts and/or components not approved by the manufacturer.

The manufacturer reserves the right to make improvements in design and changes in specifications at any time without notice and without incurring any obligation to install them on units previously sold. Specifications, descriptions, and illustrative material herein are as accurate as known at time of publication but are subject to change without notice.

In case of questions, refer to your CASE CONSTRUCTION Sales and Service Networks.

## Safety rules

### Personal safety





This is the safety alert symbol. It is used to alert you to potential personal injury hazards. Obey all safety messages that follow this symbol to avoid possible death or injury.

Throughout this manual you will find the signal words DANGER, WARNING, and CAUTION followed by special instructions. These precautions are intended for the personal safety of you and those working with you.

Read and understand all the safety messages in this manual before you operate or service the machine.

 DANGER indicates a hazardous situation that, if not avoided, will result in death or serious injury.

 WARNING indicates a hazardous situation that, if not avoided, could result in death or serious injury.

 CAUTION indicates a hazardous situation that, if not avoided, could result in minor or moderate injury.

**FAILURE TO FOLLOW DANGER, WARNING, AND CAUTION MESSAGES COULD RESULT IN DEATH OR SERIOUS INJURY.**

### Machine safety

**NOTICE:** Notice indicates a situation that, if not avoided, could result in machine or property damage.

Throughout this manual you will find the signal word Notice followed by special instructions to prevent machine or property damage. The word Notice is used to address practices not related to personal safety.

### Information

**NOTE:** Note indicates additional information that clarifies steps, procedures, or other information in this manual.

Throughout this manual you will find the word Note followed by additional information about a step, procedure, or other information in the manual. The word Note is not intended to address personal safety or property damage.

## **Safety rules - Personal safety**

Unless otherwise instructed, always perform these steps before you service the machine:

1. Park the machine on a flat, level surface.
2. Place the backhoe in the transport position with the swing lock pin installed for transport.
3. Place the loader bucket on the ground, with the bottom of the loader bucket parallel to the surface.
4. Place the direction control lever and the transmission in neutral.
5. If you need to open the hood to perform service, raise the loader arms and install the support strut.
6. Shut down the engine.
7. Place a 'Do Not Operate' tag on the key switch so that it is visible to other workers or remove the key.

---

## Safety rules - Ductile iron



### **⚠ DANGER**

**Altering cast ductile iron can cause it to weaken or break.**

**Before you weld, cut, or drill holes on any part of this machine, make sure that the part is not cast ductile iron.**

**Failure to comply will result in death or serious injury.**

D0148A

Altering cast ductile iron can cause it to weaken or break. Unauthorized modifications to cast ductile iron parts can cause death or serious injury. Do not weld, cut, drill, repair, or attach items to cast ductile iron parts on this machine.

Before you weld, cut, or drill holes on any part of this machine, make sure the part is not cast ductile iron. See your dealer if you do not know if a part is cast ductile iron.

The following items are examples of cast ductile iron parts. There may also be other parts made of cast ductile iron that are not on the list below.

- two-wheel drive steering link
- dump links
- front axle
- stabilizers
- extend-a-hoe
- swing tower
- bucket linkage
- Air-Conditioning (A/C) compressor mounting bracket

Do not make any unauthorized modifications. Consult an authorized dealer before making any changes, additions, or modifications to this machine.



## **SERVICE MANUAL**

### **Engine**

**580N EP Four-Wheel Drive (4WD) Tier 4B (final) [NHC740227 - ]**  
**580N EP Two-Wheel Drive (2WD) Tier 4B (final) [NHC740227 - ]**

## Engine - Speeds Stall test check sheet

**NOTE:** The following specifications are for engines with more than 50 hours of operation.

**NOTE:** Engine RPM speed is based on the ISO 14396 Cetane number of at least 51 and density between 820 – 845 kg/m<sup>3</sup> (1382 – 1424 lb/yd<sup>3</sup>). Fuel inlet 36.0 – 40.0 °C (96.8 – 104.0 °F).

Results from stall test procedure (fill in values accordingly)

ID	RPM test valve	Stall test component (specified value)
1		Loader hydraulic stall speed ( 2150 – 2300 RPM)
2		Backhoe hydraulic stall speed ( 2150 – 2300 RPM)
3		Torque converter stall speed ( 2025 – 2200 RPM)
4		Combined - loader hydraulic and torque converter - stall speed ( 1450 – 1720 RPM)

Stall test reference chart

ID	RPM	Results
1	2150 – 2300 RPM	All systems operating within normal specified RPM values.
2	2150 – 2300 RPM	
3	2025 – 2200 RPM	
4	1450 – 1720 RPM	
1	Above 2300 RPM	Engine problem. Check engine speeds. Refer to the engine service manual.
2	2150 – 2300 RPM	
3	Above 2200 RPM	
4	Above 1720 RPM	
1	Below 2150 RPM	Engine problem. Check engine speeds. Replace the fuel and air filters. Refer to the engine service manual.
2	2150 – 2300 RPM	
3	Below 2025 RPM	
4	Below 1450 RPM	
1	Below 2150 RPM	Hydraulic system problem(s). Check the setting of the main relief valve. Check the output of the hydraulic pump.
2	2150 – 2300 RPM	
3	2025 – 2200 RPM	
4	Below 1450 RPM	
1	Above 2300 RPM	Hydraulic system problem(s). Check the setting of the main relief valve. Check the output of the hydraulic pump. Check for leakage in the loader control valve.
2	2150 – 2300 RPM	
3	2025 – 2200 RPM	
4	Above 1720 RPM	
1	2150 – 2300 RPM	Hydraulic system problem(s). Check the setting of the main relief valve. Check the output of the hydraulic pump.
2	Below 2150 RPM	
3	2025 – 2200 RPM	
4	1450 – 1720 RPM	
1	2150 – 2300 RPM	Hydraulic system problem(s). Check the setting of the main relief valve. Check the output of the hydraulic pump.
2	Below 2150 RPM	
3	2025 – 2200 RPM	
4	1450 – 1720 RPM	
1	2150 – 2300 RPM	Torque converter or transmission problems.
2	2150 – 2300 RPM	
3	Above 2200 RPM	
4	Above 1720 RPM	
1	2150 – 2300 RPM	Torque converter or transmission problems.
2	2150 – 2300 RPM	
3	Below 2025 RPM	
4	Below 1450 RPM	

Engine - Engine and crankcase

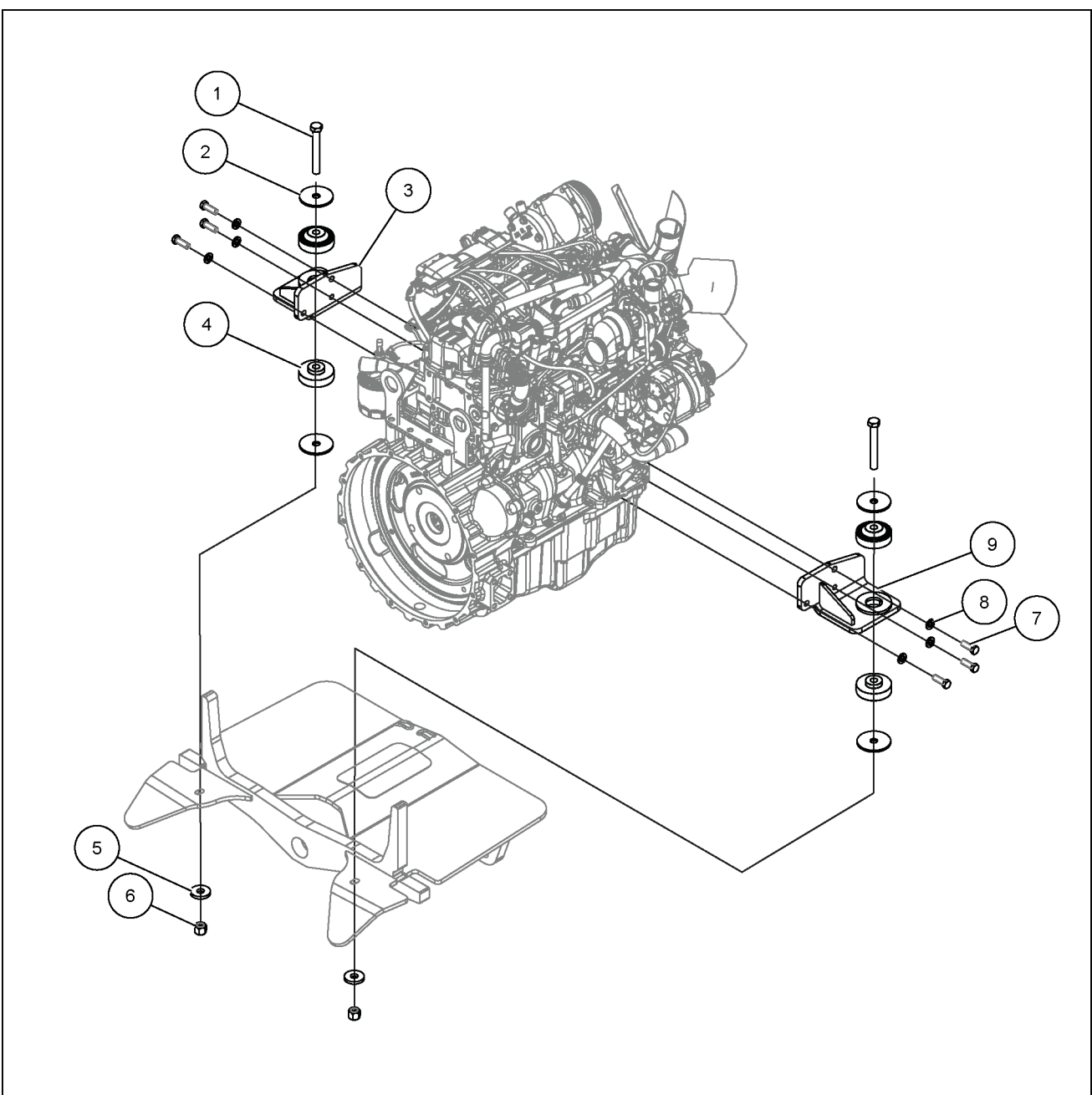

RAIL12UTL0338GA 1

## Engine - Prepare - Stall tests

Do the stall test to find the cause of poor performance.

The main relief valve must be set within specifications to achieve accurate readings when performing the following stall tests.

The engine is run at full throttle and the transmission and hydraulic systems are engaged separately, and then together.

Comparing the engine speeds from the stall test with the check sheets in this section will help to find the cause of the problem. It can be necessary to check a separate system to find the exact cause of the problem.

Use a photo tachometer or other tachometer of equal accuracy to get accurate results from the stall test.

The engine, transmission and hydraulic system must be at operating temperature before doing the stall test. Heat the oil according to instructions in this section.

### Machines with standard transmission

1. Apply the parking brake.
2. Move the transmission gear selector into fourth gear.
3. Lock the brake pedals together. Put your foot on the service brakes and hold the machine with service brakes.
4. Release the parking brake.
5. With the engine running at low idle, move the direction control lever forward.
6. Slowly increase the engine speed to full throttle.
7. If the machine begins to move at any time, decrease the engine speed to low idle and stop the engine.

### Machines with S-Type and H-Type transmissions

1. Apply the parking brake.
2. Place the automatic/manual switch in the manual position.
3. Select fourth gear on the range selector.
4. Lock the brake pedals together. Put your foot on the service brakes and hold the machine with service brakes.
5. Release the parking brake.
6. With the engine running at low idle, move the direction control lever forward.
7. Slowly increase the engine speed to full throttle.
8. If the machine begins to move at any time, decrease the engine speed to low idle and stop the engine. Refer to sections **Parking brake discs - Inspect (33.110)**, **Parking brake discs - Test (33.110)** and **Parking brake discs - Check (33.110)**.

### **Procedure to heat the torque converter and the hydraulic oil**

1. Apply the parking brake.
2. Start and run the engine at low idle.
3. Run the engine at full throttle, hold the loader control lever in the rollback position for 15 seconds.
4. Return the loader control lever to neutral for 15 seconds.
5. Return the boom control lever to neutral for 15 seconds.
6. Repeat steps 3 and 4 until the temperature of the oil is **52 °C (126 °F)**. The side of the reservoir will be very warm at this temperature.
7. With the engine running at low idle, move the transmission control to fourth gear and the direction control lever to forward.
8. Run the engine at full throttle for 15 seconds.
9. Decrease the engine speed to low idle and move the direction control lever to neutral for 15 seconds.
10. Repeat steps 6 through 8 until the pointer in the gauge for transmission oil temperature is in the center of the green zone of the gauge for transmission oil temperature.

### **Stall test procedure**

1. Prepare the machine for the stall test according to instructions in this section.
2. Heat the oil according to instructions in this section.
3. Apply the parking brake and start the engine.
4. With the engine running at full throttle, hold the loader control lever in the lift position and read the tachometer. Record the reading on line 1 of the check sheet.
5. With the engine running at full throttle and boom in travel lock, hold the dipper lever in the in position and read the tachometer. Record the reading on line 2 of the check sheet.
6. Decrease the engine speed to low idle.
7. Move the transmission control lever to fourth gear.

**NOTE:** For machines with S-Type and H-Type transmissions, place the automatic/manual switch in the manual position.

8. Lock the brake pedals together. Put your foot on the service brakes and hold the machine with service brakes.
9. Release the parking brake.
10. Move the direction control lever to forward.
11. Slowly increase the engine speed to full throttle and read the tachometer. Record the reading on line 3 on the check sheet.

12. With the transmission control lever in fourth gear, the direction control lever in forward, and the engine running at full throttle, hold the loader control lever in the lift position and read the tachometer. Record the reading on line 4 on the check sheet.
13. Decrease the engine speed to low idle, move the directional control lever to neutral.
14. Run the engine at low idle for two minutes and then stop the engine.
15. See the check sheet to understand the results of the stall test.

## Engine - Remove

**Prior operation:**

Remove the engine hood. See **Engine hood - Remove (90.105)**.

**Prior operation:**

Remove the Diesel Oxidation Catalyst (DOC) tray. See **Diesel Oxidation Catalyst (DOC) - Remove (10.501)**

**Prior operation:**

Drain the engine cooling system. See **Radiator - Drain fluid (10.400)**.

**Prior operation:**

Remove the engine cooling system. See **Radiator - Remove (10.400)**.

**Prior operation:**

If equipped, evacuate the air-conditioning system. See **Air conditioning - Charging Air conditioner system evacuation and recharging (50.200)**

1. If equipped, disconnect electrical connectors **(1)** and **(2)**.

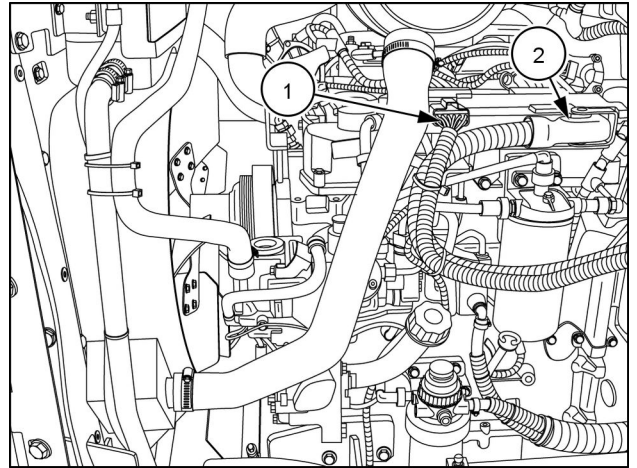

RAIL14FRK0114BA 1

2. If equipped, disconnect the A/C high pressure line.
3. If equipped, disconnect the A/C low pressure line.
4. If equipped, disconnect the A/C condenser voltage wire.
5. Disconnect fuel lines **(1)** and **(2)**.

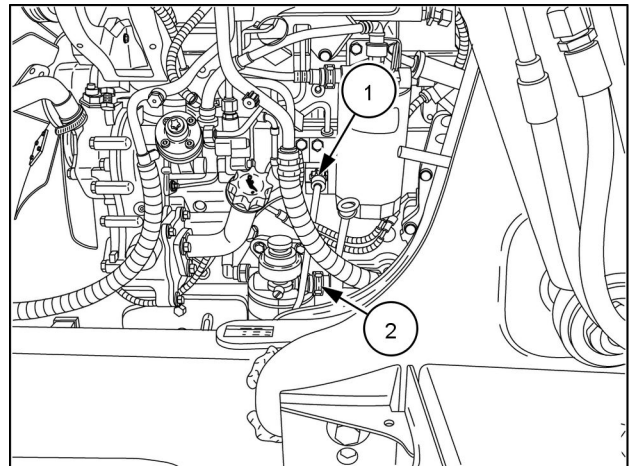

RAPH11TLB0041BA 2

6. Disconnect the water sensor electrical connector (not shown).

**NOTE:** Water sensor is located at the bottom of the primary fuel filter.

7. Disconnect the glow plug control unit electrical connector (1).

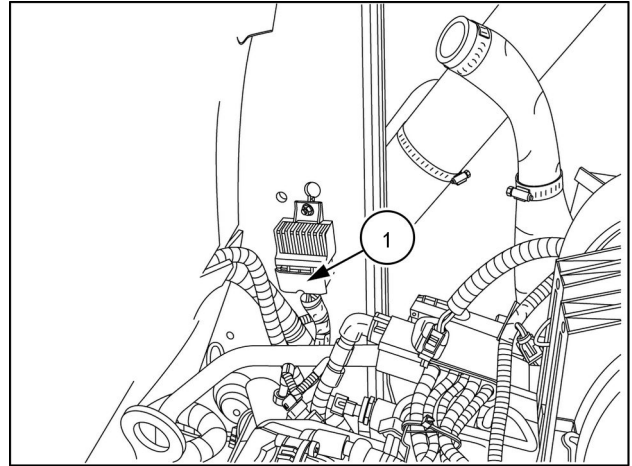

RAPH11TLB0021BA 3

8. Remove the supporting bracket (1) and hanging barrier curtain (2).

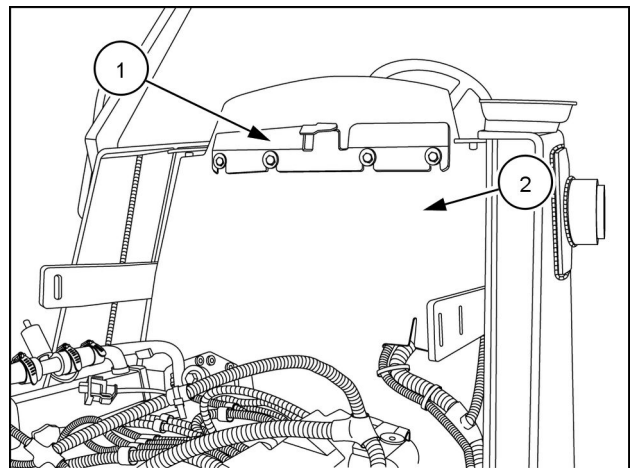

RAIL14UTL0095BA 4

9. Disconnect the heater hose (1).

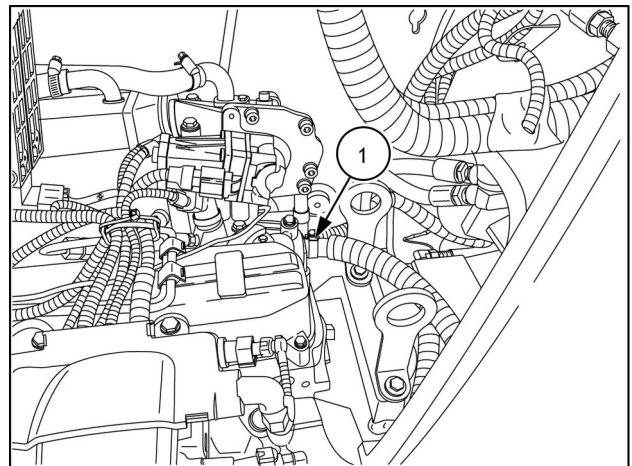

RAPH11TLB0039BA 5

10. Disconnect the air temperature sensor.

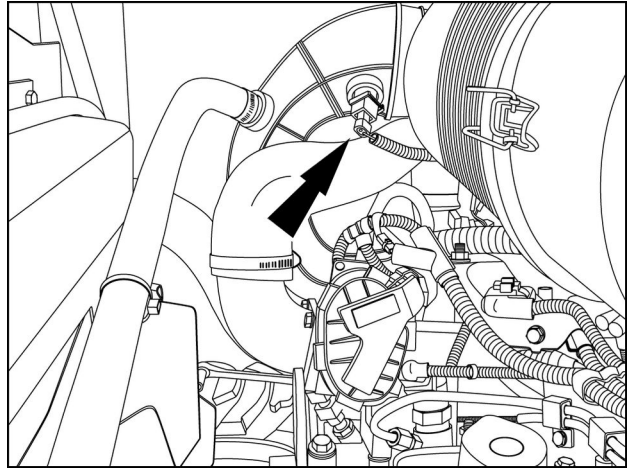

RAIL14FRK0115BA 6

11. Remove the air intake hose clamp.

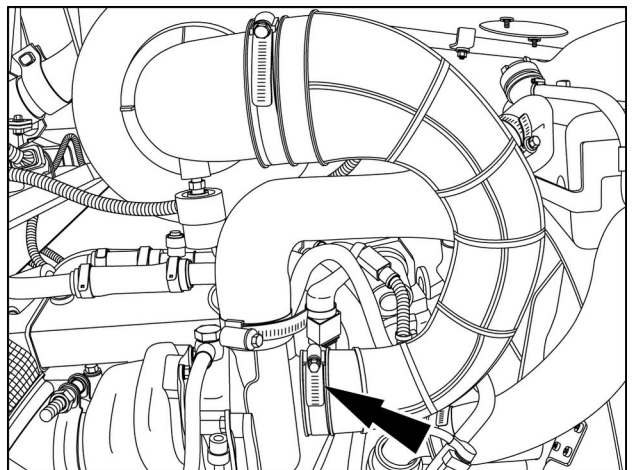

RAIL14FRK0104BA 7

**NOTE:** For assembly purposes, identify and label all electrical connectors.

12. Disconnect the wires from the air restriction indication switch.
13. Remove the air filter assembly and cap all openings.

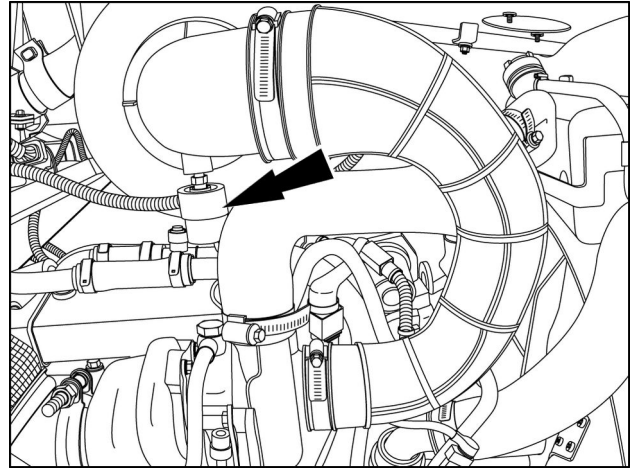

RAIL14FRK0104BA 8

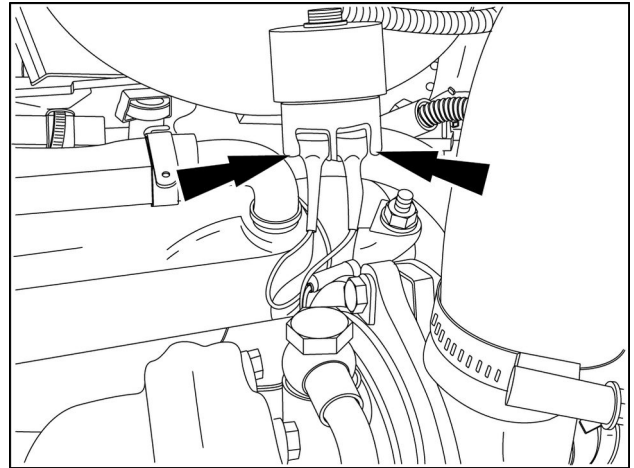

RAIL14FRK0122BA 9

14. Disconnect the wiring harness connector (1) and the positive battery cable (2) from the rear of the alternator.

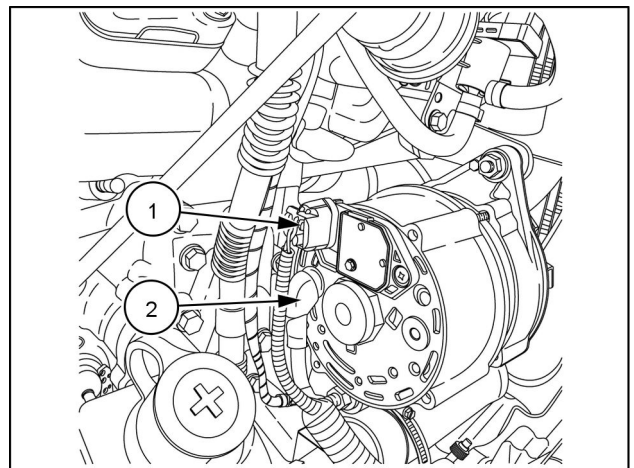

RAPH12FRK0163AA 10

15. If equipped, remove the battery disconnect switch bracket from the frame and set aside.

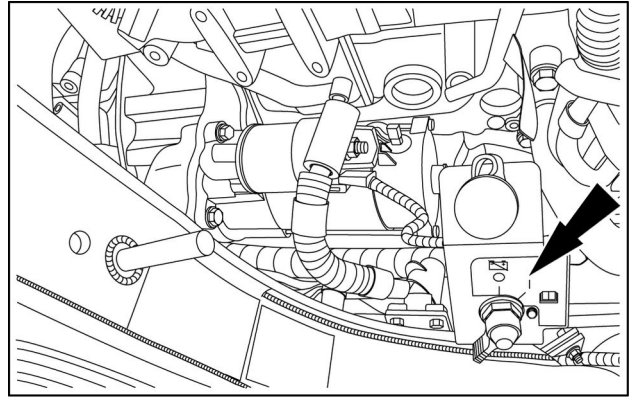

RAIL14TLB0403AA 11

16. Remove the nut (3), disconnect the wire harness (4) and positive battery cable (2) from the terminal on the starter (1).

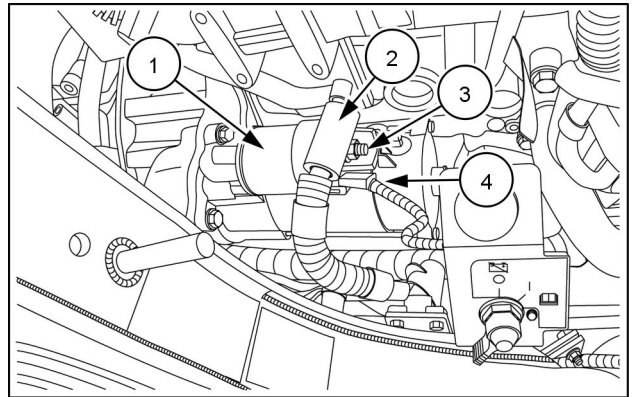

RAIL14TLB0403AA 12

17. Disconnect the ground strap.

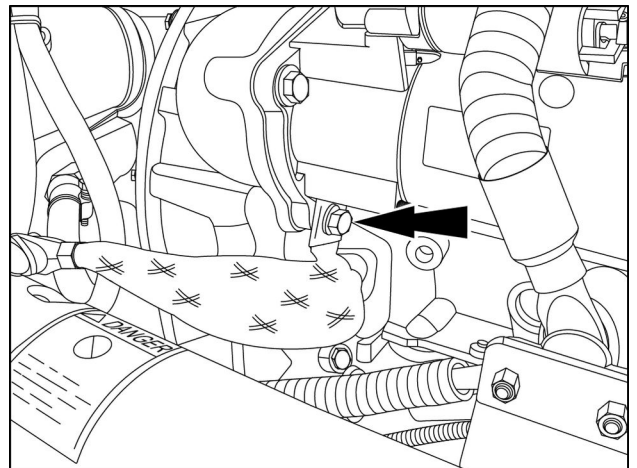

RAIL14FRK0129BA 13

18. On the right-hand side of the engine remove both caps to access the flex plate bolts.

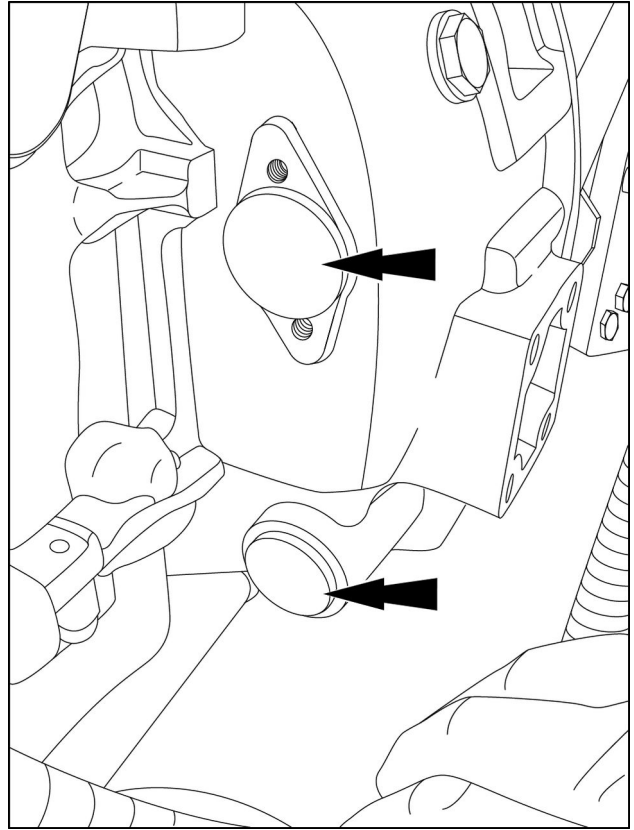

RAIL14FRK0141BA 14

19. Insert the engine turning tool **380003372** into the lower opening and rotate the flywheel until the flex plate bolt is visible in the top opening.

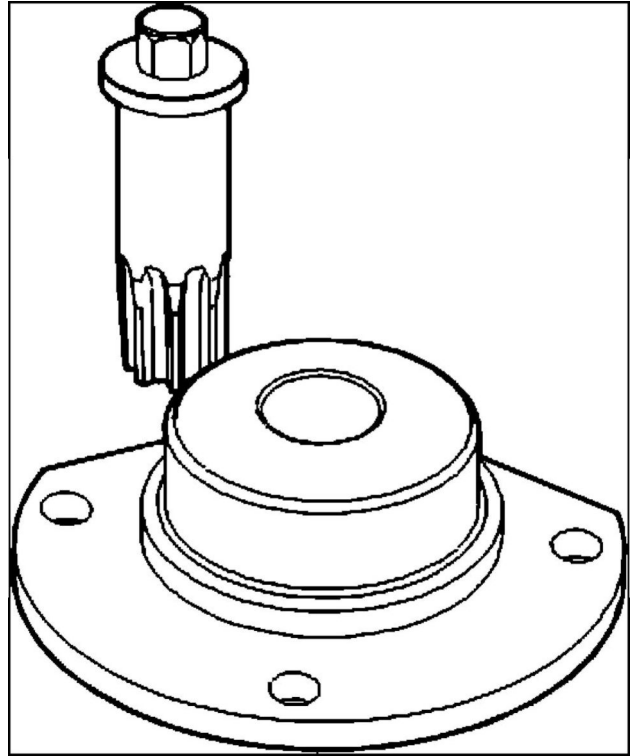

RAPH12FRK0979BA 15

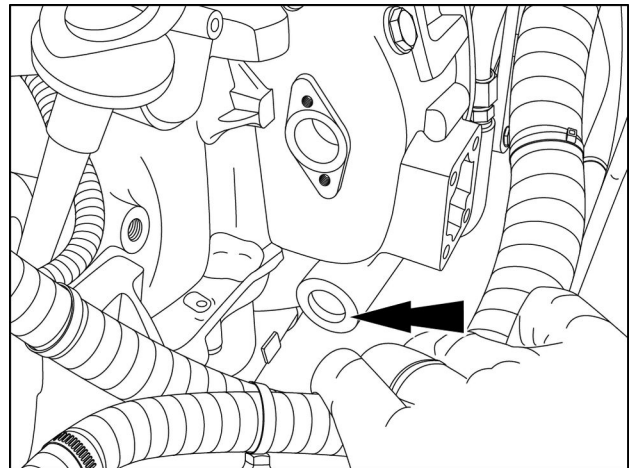

RAIL14FRK0139BA 16

20. Remove all the bolts that fasten the flywheel to the flex plate.

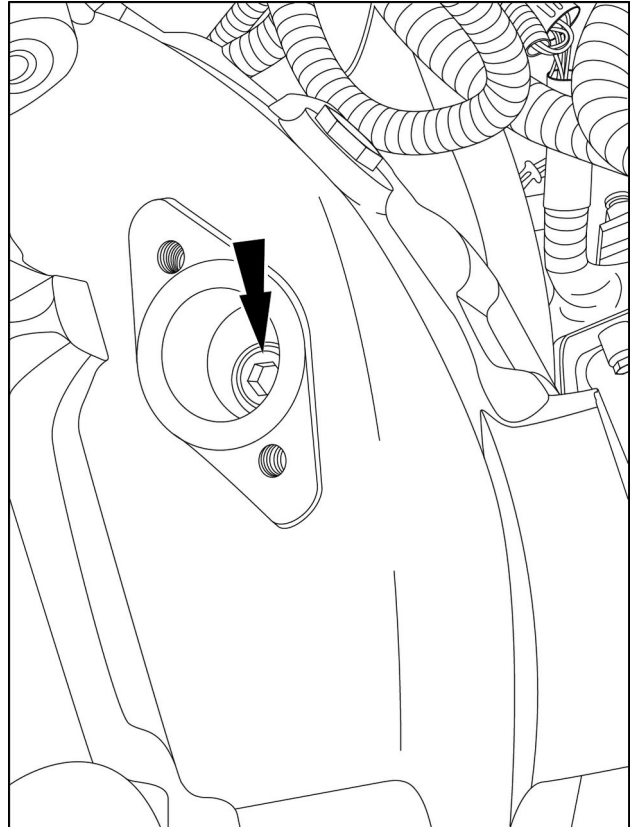

RAIL14FRK0140BA 17

21. Support the engine using safe, lifting equipment.

**⚠ DANGER**

**Heavy parts!**  
**Support designated component(s) with adequate lifting equipment.**  
**Failure to comply will result in death or serious injury.**

D0018A

**Specification**

Engine weight (approximate)	<b>363 kg (800 lb)</b>
-----------------------------	------------------------

22. Remove all the bolts and washers that fasten the transmission to the flywheel housing (two shown).

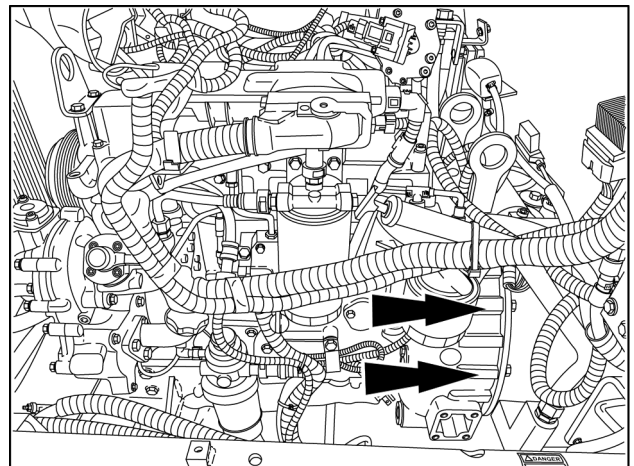

RAPH12FRK0977BA 18

23. Loosen the motor mount-to-frame bolts on both sides of the engine.
24. Remove all motor mount-to-engine bolts on both sides of the engine.

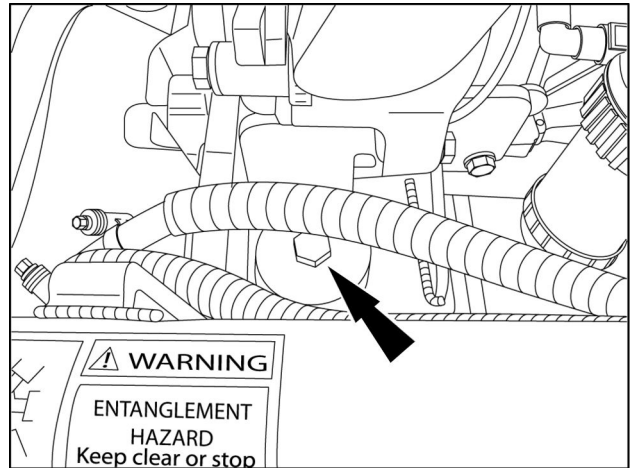

RAPH12FRK0103BA 19

**NOTICE:** Avoid machine damage. Maintain adequate clearance between the engine and machine frame. Make sure the engine components **DO NOT** come in contact or hang up on the frame or frame components during engine removal.

25. Carefully raise and remove the engine from the machine.
26. Place the engine on the repair stand and repair or replace as necessary.

## Engine - Install

### **⚠ DANGER**

#### **Heavy objects!**

Lift and handle all heavy components using lifting equipment with adequate capacity. Always support units or parts with suitable slings or hooks. Make sure the work area is clear of all bystanders. Failure to comply will result in death or serious injury.

D0076A

### Specification

Engine weight (approximate)	<b>363 kg (800 lb)</b>
-----------------------------	------------------------

1. Attach an appropriate lifting device to the three engine lift eyelets (1) on the engine as shown.

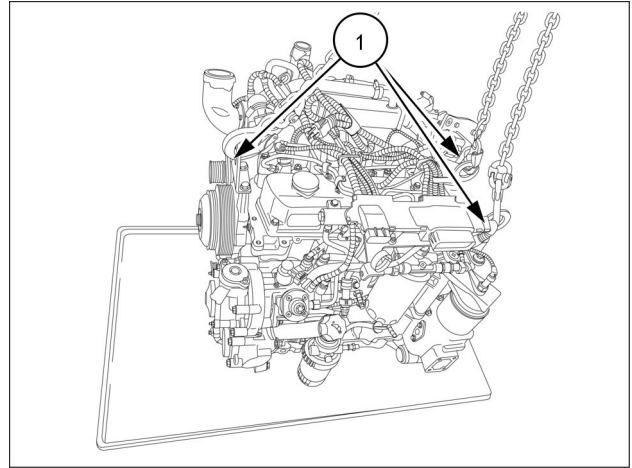

RAPH12FRK0643HA 1

**NOTICE:** Avoid machine damage. Maintain adequate clearance between the engine and machine frame. Make sure the engine components **DO NOT** come in contact or hang up on the frame or frame components during engine removal.

2. Carefully raise and position the engine in the machine.
3. Install all the bolts and washers that fasten the transmission to the flywheel housing (only two shown). Do not tighten at this time.

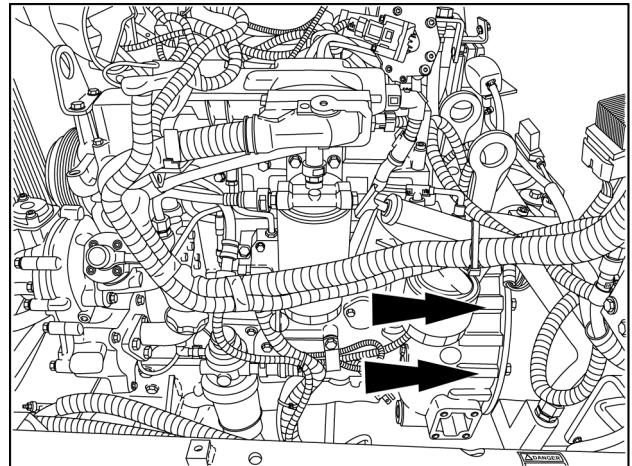

RAPH12FRK0977BA 2



**Suggest:**

**If the above button click is invalid.**

**Please download this document**

**first, and then click the above link**

**to download the complete manual.**

**Thank you so much for reading**

4. Install all motor mount-to-engine bolts on both sides of the engine. Tighten to specification.
5. Install the motor mount-to-frame bolts on both sides of the engine.

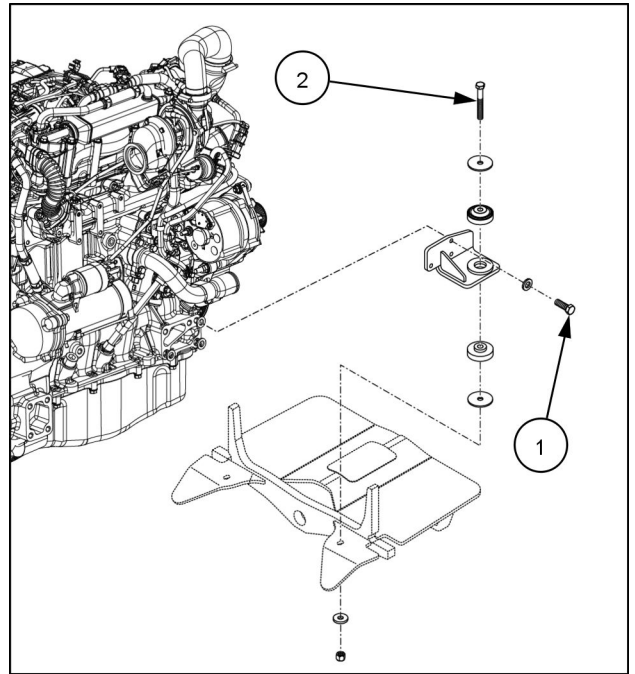

RAIL14TLB1008BA 3

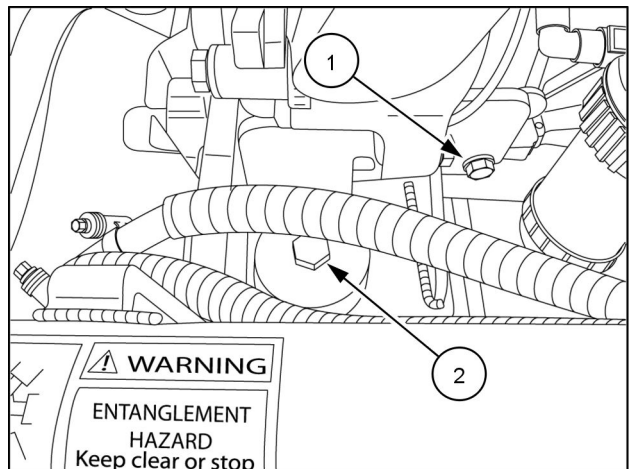

RAPH12FRK0103BA 4

**Specification**

Mount-to-engine torque	89 – 107 N·m (66 – 79 lb ft)
Mount-to-frame torque	178 – 240 N·m (131 – 177 lb ft)

6. Tighten all the bell housing bolts to specification.

**NOTE:** View is from underneath the machine.

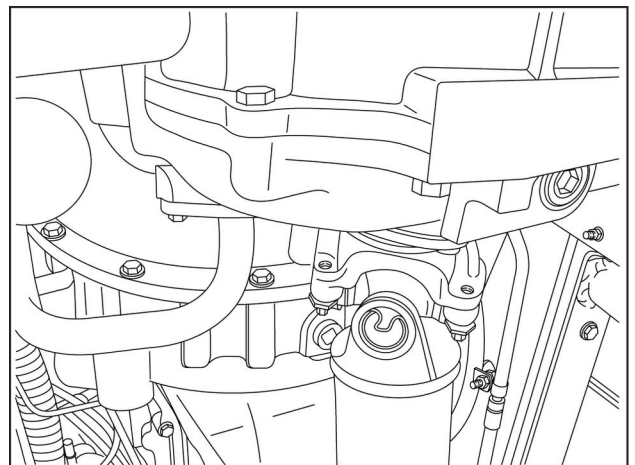

RAPH11TLB0020BA 5

**<https://www.ebooklibonline.com>**

Hello dear friend!

Thank you very much for reading.

Enter the link into your browser.

The full manual is available for immediate download.

**<https://www.ebooklibonline.com>**