

**580N**  
**580SN-WT**  
**580SN**  
**590SN**  
Tractor Loader Backhoe

**SERVICE MANUAL**

**Part number 84516378**

English

July 2011

*Replaces part number 84390833*



# Contents

---

## INTRODUCTION

## HYDRAULIC, PNEUMATIC, ELECTRICAL, ELECTRONIC SYSTEMS A

PRIMARY HYDRAULIC POWER SYSTEM.....	A.10.A
SECONDARY HYDRAULIC POWER SYSTEM.....	A.12.A
ELECTRICAL POWER SYSTEM .....	A.30.A
FAULT CODES.....	A.50.A

## ENGINE AND PTO IN ..... B

ENGINE .....	B.10.A
FUEL AND INJECTION SYSTEM.....	B.20.A
EXHAUST SYSTEM.....	B.40.A
ENGINE COOLANT SYSTEM .....	B.50.A
STARTING SYSTEM .....	B.80.A

## TRANSMISSION, DRIVE AND PTO OUT ..... C

TRANSMISSION Power Shuttle.....	C.20.C
TRANSMISSION Powershift .....	C.20.E

## AXLES, BRAKES AND STEERING..... D

FRONT AXLE .....	D.10.A
REAR AXLE .....	D.12.A
STEERING Hydraulic.....	D.20.C
SERVICE BRAKE Hydraulic.....	D.30.C
PARKING BRAKE Mechanical .....	D.32.B
WHEELS AND TRACKS Wheels.....	D.50.C

## FRAME AND CAB ..... E

FRAME Primary frame .....	E.10.B
SHIELD .....	E.20.A
USER CONTROLS AND SEAT .....	E.32.A
USER CONTROLS AND SEAT Operator seat.....	E.32.C
USER PLATFORM .....	E.34.A

ENVIRONMENT CONTROL Air-conditioning system .....	E.40.C
<b>FRAME POSITIONING .....</b>	<b>F</b>
STABILISING Working stabilising .....	F.20.D
<b>TOOL POSITIONING .....</b>	<b>G</b>
LIFTING .....	G.10.A
<b>HITCH AND WORKING TOOL .....</b>	<b>H</b>
BOOM Lift .....	H.20.B
BOOM Swing .....	H.20.D
DIPPER Lift.....	H.25.B
DIPPER Extension .....	H.25.F
ARM TOOL ATTACHMENT Tilt.....	H.30.C
<b>EXCAVATING AND LANDSCAPING .....</b>	<b>J</b>
DIGGING Non-articulated digging tools .....	J.20.B
CARRYING Articulated tools .....	J.50.C

**<https://www.ebooklibonline.com>**

Hello dear friend!

Thank you very much for reading.

Enter the link into your browser.

The full manual is available for immediate download.

**<https://www.ebooklibonline.com>**



## **INTRODUCTION**

---

## Safety rules

### **⚠ DANGER**

Improper operation or service of this machine can result in an accident.  
Do not operate this machine or perform any lubrication, maintenance, or repair on it until you have read and understood the operation, lubrication, maintenance, and repair information.  
Failure to comply will result in death or serious injury.

D0010A

### **⚠ WARNING**

Maintenance hazard!  
Always perform all service procedures punctually at the intervals stated in this manual. This ensures optimum performance levels and maximum safety during machine operation.  
Failure to comply could result in death or serious injury.

W0132A

### **⚠ WARNING**

Pressurized system!  
Before attempting any service procedure, it is your responsibility to know the number of accumulators on the machine, and the correct procedure for releasing the pressure of each accumulator.  
Failure to comply could result in death or serious injury.

W0136A

**NOTICE:** *Extreme working and environmental conditions require shortened service intervals.*

Use Case fluids, lubricants, and filters for the best protection and performance of your machine. All fluids, lubricants, and filters must be disposed of in compliance with environmental standards and regulations. Contact your dealer with any questions regarding the service and maintenance of this machine.

Read the safety decals and information decals on the machine. Read the Operator's Manual and safety manual. Understand the operation of the machine before you start any service.

Before you service the machine, put a 'Do Not Operate' tag on the steering wheel or over the key switch. Ensure the tag is at a location where everyone who might operate or service the machine may see clearly. One tag is included with your new machine. Additional tags are available from your dealer.

## Plastic and resin parts

- Avoid using gasoline, paint thinner, etc. when cleaning plastic parts, console, instrument cluster, etc.
- Use only water, mild soap, and a soft cloth when you clean these parts.
- Using gasoline, thinners, etc. can cause discoloration, cracking, or deformation of the part being cleaned.

## **Safety rules**

Before you weld, cut, or drill holes on any part of this machine, make sure the part is not cast ductile iron. See your dealer if you do not know if a part is cast ductile iron. The following are cast ductile iron parts:

- two wheel drive steering link
- dump links
- front axle
- stabilizers
- extendable dipper
- swing tower
- bucket linkage

Unauthorized modifications to cast ductile iron parts can cause injury or death. Welding, cutting, or drilling can cause cast ductile iron to break. Do not weld, cut, or drill to repair or to attach items to cast ductile iron parts on this machine.

---

## Safety rules

Before welding on the machine you must do the following.  
If you have any questions about welding on the machine contact your dealer.

- Disconnect the batteries.
- Disconnect the alternator terminal wires.
- Disconnect the instrument cluster.
  - One connector for mechanical fuel injection engines.
  - Two connectors for HPCR (high pressure common rail) engines.
- Disconnect the engine control unit (ECU), if equipped (three connectors).

**NOTE:** The third connector is behind the hose in the illustration.

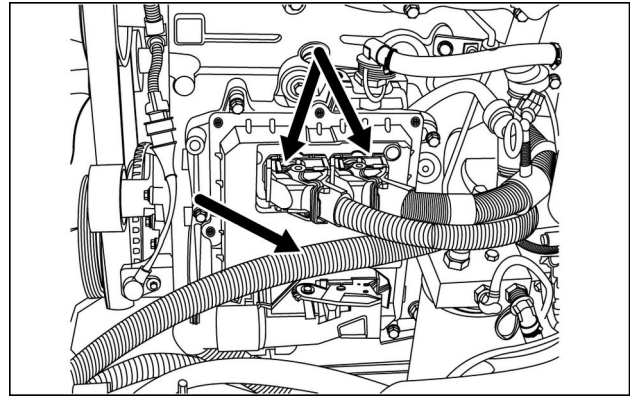

RCPH10TLB046AAF 1

- Disconnect the controller for backhoe pilot controls, if equipped (one connector).
- Disconnect the transmission controller, if equipped (one connector, located under the front steering cowling).
- Disconnect the controller for the loader 4 in 1 bucket or auxiliary hydraulics, if equipped (one connector, located under the loader valve at the rear, left underside of the machine).

## **Safety rules**

Unless otherwise instructed, always perform these steps before you service the machine:

1. Park the machine on a flat, level surface.
2. Place the backhoe in the transport position with the swing lock pin installed for transport.
3. Place the loader bucket on the ground, with the bottom of the loader bucket parallel to the surface.
4. Place the direction control lever and the transmission in neutral.
5. If you need to open the hood to perform service, raise the loader arms and install the support strut.
6. Shut down the engine.
7. Place a 'Do Not Operate' tag on the key switch so that it is visible to other workers or remove the key.

## Battery - Basic instructions

### ⚠ WARNING

**Explosive gas!**

**Batteries emit explosive hydrogen gas and other fumes while charging. Ventilate the charging area. Keep the battery away from sparks, open flames, and other ignition sources. Never charge a frozen battery.**

**Failure to comply could result in death or serious injury.**

W0005A

### ⚠ WARNING

**Hazardous chemicals!**

**Battery electrolyte contains sulfuric acid. Contact with skin and eyes could result in severe irritation and burns. Always wear splash-proof goggles and protective clothing (gloves and aprons). Wash hands after handling.**

**Failure to comply could result in death or serious injury.**

W0006A

- Do not run the engine with the alternator wires disconnected.
- Before using an electric welder, disconnect the alternator wires, instrument cluster and batteries. Disconnect the ECU connectors.
- Do not use a steam cleaner or a cleaning solvent to clean the alternator.
- Keep the battery vents clean. Ensure the battery vents are not restricted.

### Disconnect Battery

1. Park the machine on a level surface. Raise the loader and lock the support strut to hold the loader in the upright position. .

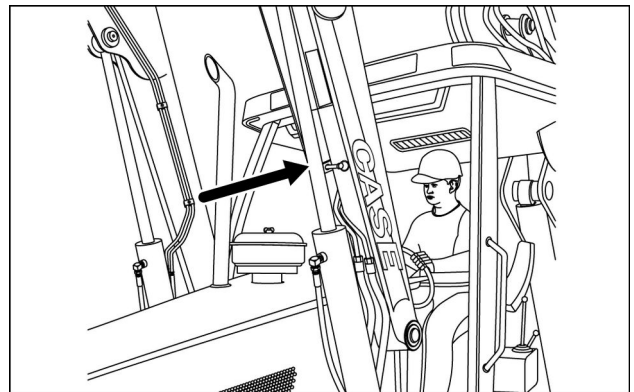

RCPH10TLB022AAL 1

2. Remove the battery cover hardware.

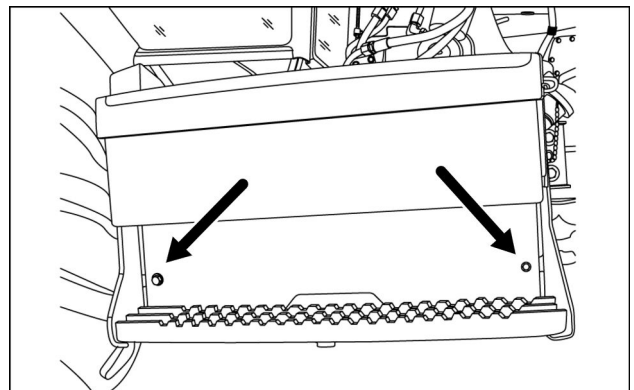

RCPH11TLB001AAM 2

## INTRODUCTION

3. Remove the battery cover.

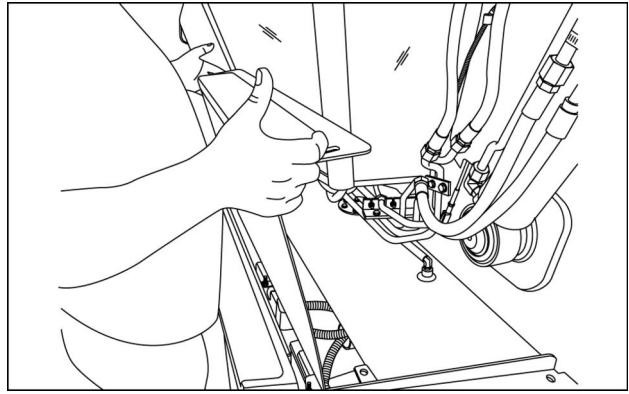

RCPH11TLB002AAM 3

4. Disconnect the negative battery cable from the negative battery terminal.

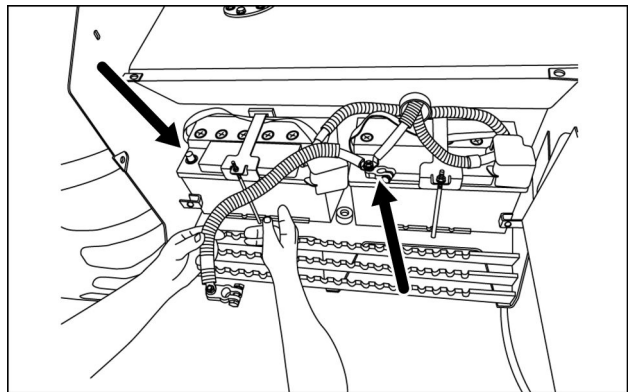

RCPH11TLB003AAM 4

## ELECTRONIC SYSTEM - Basic instructions

The diagnostic/service tool port is located in the fuse box at the side console. Connect the Electronic Service Tool (EST) or DATAR to this port to update software and/or perform service and diagnostic tests.

1. Turn the thumb screws (1) to loosen the panel cover (2) for the fuse box. Remove the panel cover.

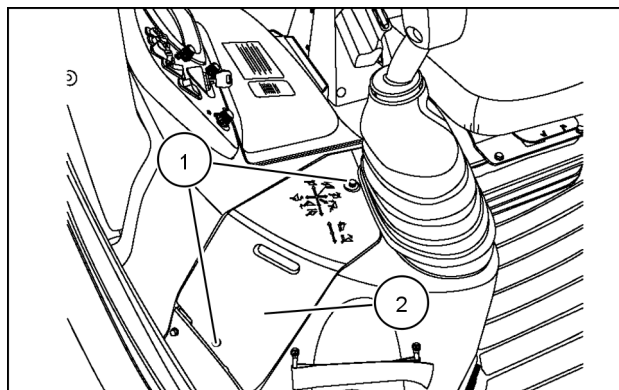

RCPH10TLB437AAF 1

2. Unscrew the cap for the diagnostic/service tool port.

**NOTE:** You do not have to remove the fuse box covers.

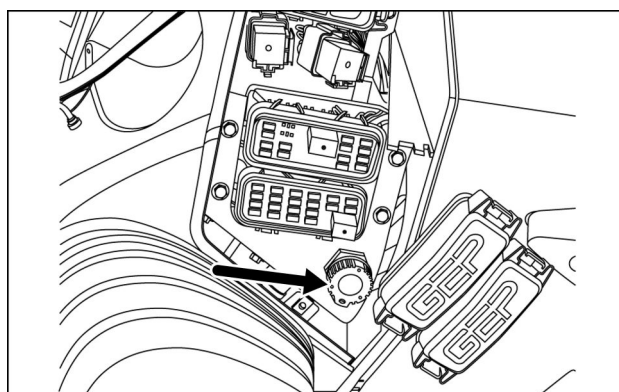

RCPH10TLB302AAF 2

---

## Heater - Basic instructions

The heater coolant shutoff valve controls the flow of hot coolant to the heater.

- In warm ambient temperatures, turn the shutoff valve clockwise to stop hot coolant flow to the heater.
- In cold ambient temperatures, turn the shutoff valve counter-clockwise to allow hot coolant to flow to the heater.

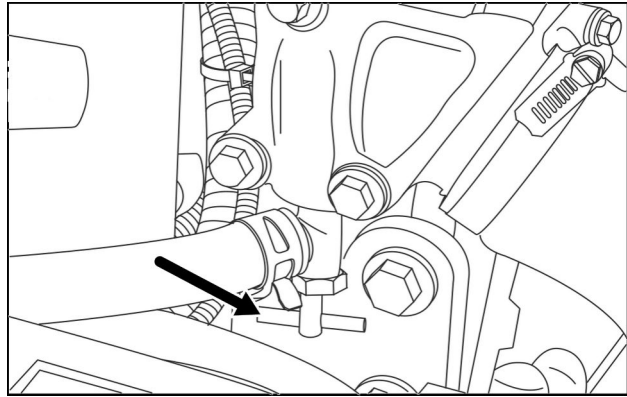

RCPH10TLB159AAF 1

## Basic instructions

### **⚠ WARNING**

#### **Crushing hazard!**

**If you service the machine with the loader lift arms raised, always use the support strut. Remove the retaining pin and place the support strut onto the cylinder rod. Install the retaining pin into the support strut. Lower the lift arms onto the support strut.**

**Failure to comply could result in death or serious injury.**

W0230A

Raise and support loader lift arms:

1. Empty the loader bucket.
2. Raise the loader lift arms to the maximum height.
3. Shut down the engine.

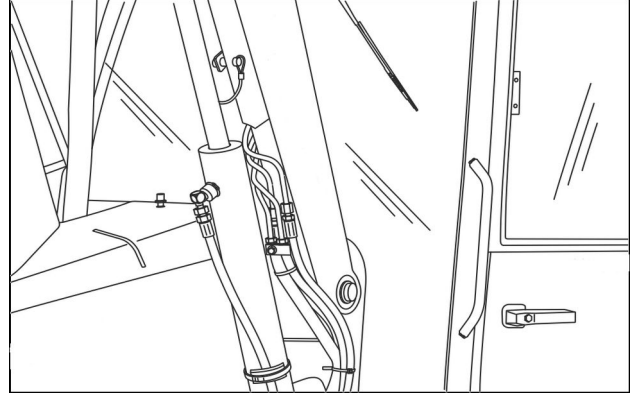

RCPH10TLB230AAF 1

4. Remove the retaining pin.
5. Lower the support strut onto the cylinder rod.
6. Install the retaining pin.

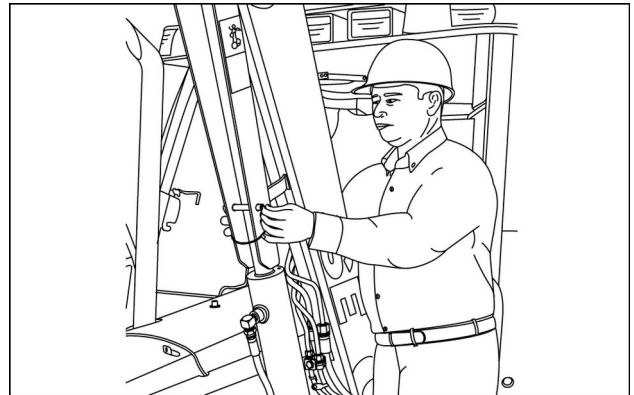

RCPH10TLB221AAF 2

7. Start the engine.
8. Slowly lower the lift arms so that the end of the support strut rests on the cylinder.

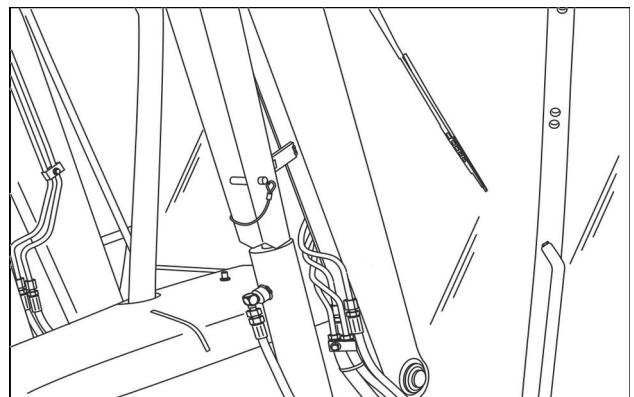

RCPH10TLB227AAF 3

## INTRODUCTION

### Lower supported loader lift arms:

1. Raise the lift arms so that the end of the support strut no longer rests on the cylinder.
2. Shut down the engine.

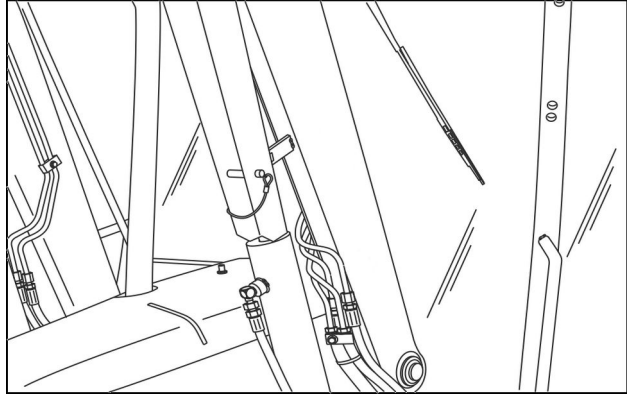

RCPH10TLB227AAF 4

3. Remove the retaining pin from the support strut.
4. Raise the support strut up to the storage position and secure with the retaining pin, as shown.

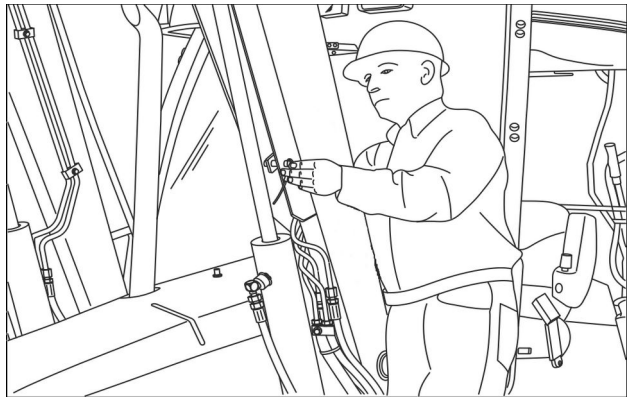

RCPH10TLB231AAF 5

5. Start the engine.
6. Lower the loader to the ground.

## Basic instructions

Open the hood:

1. Shut down the engine.
2. Turn the handle counter-clockwise to release the hood latch.

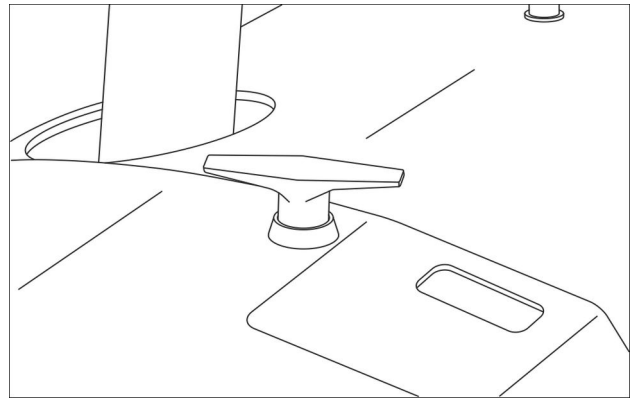

RCPH10TLB166AAF 1

3. Lift the hood and rotate forward.

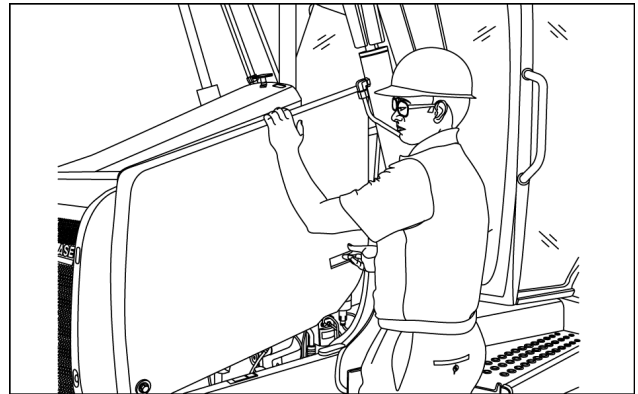

RCPH10TLB356AAF 2

**NOTICE:** To avoid damage to the hood parts, always close the hood before moving the loader.

Close the hood:

1. Lower the hood.
2. Turn the handle clockwise to lock the hood latch.

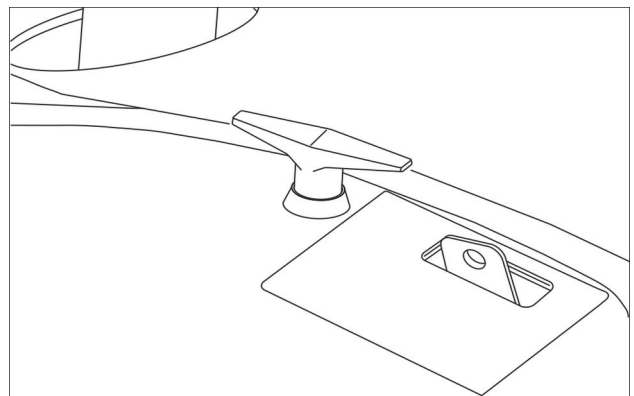

RCPH10TLB167AAF 3

## Torque



Use the torques in this chart when special torques are not given. These torques apply to fasteners with both UNC and UNF threads as received from suppliers dry, or when lubricated with engine oil. Not applicable if special graphite lubricants, Molydisulfide greases, or other extreme pressure lubricants are used.

### Decimal hardware

#### Grade 5 bolts, nuts, and studs

Size	Nm	lb in/lb ft
1/4 in	12 - 15 Nm	108 - 132 lb in
5/16 in	23 - 28 Nm	204 - 252 lb in
3/8 in	48 - 57 Nm	420 - 504 lb in
7/16 in	73 - 87 Nm	54 - 64 lb ft
1/2 in	109 - 130 Nm	80 - 96 lb ft
9/16 in	149 - 179 Nm	110 - 132 lb ft
5/8 in	203 - 244 Nm	150 - 180 lb ft
3/4 in	366 - 439 Nm	270 - 324 lb ft
7/8 in	542 - 651 Nm	400 - 480 lb ft
1 in	787 - 944 Nm	580 - 696 lb ft
1-1/8 in	1085 - 1193 Nm	800 - 880 lb ft
1-1/4 in	1519 - 1681 Nm	1120 - 1240 lb ft
1-3/8 in	1980 - 2278 Nm	1460 - 1680 lb ft
1-1/2 in	2631 - 2983 Nm	1940 - 2200 lb ft



Markings for Grade 5 hardware

#### Grade 8 bolts, nuts, and studs

Size	Nm	lb in/lb ft
1/4 in	16 - 20 Nm	144 - 180 lb in
5/16 in	33 - 39 Nm	288 - 348 lb in
3/8 in	61 - 73 Nm	540 - 648 lb in
7/16 in	95 - 114 Nm	70 - 84 lb ft
1/2 in	149 - 179 Nm	110 - 132 lb ft
9/16 in	217 - 260 Nm	160 - 192 lb ft
5/8 in	298 - 358 Nm	220 - 264 lb ft
3/4 in	515 - 618 Nm	380 - 456 lb ft
7/8 in	814 - 976 Nm	600 - 720 lb ft
1 in	1220 - 1465 Nm	900 - 1080 lb ft
1-1/8 in	1736 - 1953 Nm	1280 - 1440 lb ft
1-1/4 in	2468 - 2712 Nm	1820 - 2000 lb ft
1-3/8 in	3227 - 3688 Nm	2380 - 2720 lb ft
1-1/2 in	4285 - 4827 Nm	3160 - 3560 lb ft

Markings for Grade 8 hardware

**NOTE:** Use thick nuts with Grade 8 bolts.

**Metric hardware**

**Grade 8.8 bolts, nuts, and studs**

Size	Nm	lb in/lb ft
4 mm	3 - 4 Nm	24 - 36 lb in
5 mm	7 - 8 Nm	60 - 72 lb in
6 mm	11 - 12 Nm	96 - 108 lb in
8 mm	26 - 31 Nm	228 - 276 lb in
10 mm	52 - 61 Nm	456 - 540 lb in
12 mm	90 - 107 Nm	66 - 79 lb ft
14 mm	144 - 172 Nm	106 - 127 lb ft
16 mm	217 - 271 Nm	160 - 200 lb ft
20 mm	434 - 515 Nm	320 - 380 lb ft
24 mm	675 - 815 Nm	500 - 600 lb ft
30 mm	1250 - 1500 Nm	920 - 1100 lb ft
36 mm	2175 - 2600 Nm	1600 - 1950 lb ft

Markings for Grade 8.8 hardware



**Grade 10.9 bolts, nuts and studs**

Size	Nm	lb in/lb ft
4 mm	4 - 5 Nm	36 - 48 lb in
5 mm	9 - 11 Nm	84 - 96 lb in
6 mm	15 - 18 Nm	132 - 156 lb in
8 mm	37 - 43 Nm	324 - 384 lb in
10 mm	73 - 87 Nm	54 - 64 lb ft
12 mm	125 - 150 Nm	93 - 112 lb ft
14 mm	200 - 245 Nm	149 - 179 lb ft
16 mm	310 - 380 Nm	230 - 280 lb ft
20 mm	610 - 730 Nm	450 - 540 lb ft
24 mm	1050 - 1275 Nm	780 - 940 lb ft
30 mm	2000 - 2400 Nm	1470 - 1770 lb ft
36 mm	3500 - 4200 Nm	2580 - 3090 lb ft

Markings for Grade 10.9 hardware



**Grade 12.9 bolts, nuts, and studs**

Size	Nm	lb in/lb ft
Typically the torque values specified for grade 10.9 hardware can be used satisfactorily on grade 12.9 hardware.		

Markings for Grade 12.9 hardware



**Steel hydraulic fittings****37° flare fitting**

Tube outside diameter/Hose inside diameter		Thread size	Nm	lb in/lb ft
mm	inch			
6.4 mm	1/4 in	7/16-20 in	8 - 16 Nm	72 - 144 lb in
7.9 mm	5/16 in	1/2-20 in	11 - 22 Nm	96 - 192 lb in
9.5 mm	3/8 in	9/16-18 in	14 - 34 Nm	120 - 300 lb in
12.7 mm	1/2 in	3/4-16 in	20 - 57 Nm	180 - 504 lb in
15.9 mm	5/6 in	7/8-14 in	34 - 79 Nm	300 - 696 lb in
19.0 mm	3/4 in	1-1/16-12 in	54 - 108 Nm	40 - 80 lb ft
22.2 mm	7/8 in	1-3/16-12 in	81 - 135 Nm	60 - 100 lb ft
25.4 mm	1 in	1-5/16-12 in	102 - 158 Nm	75 - 117 lb ft
31.8 mm	1-1/4 in	1-5/8-12 in	169 - 223 Nm	125 - 165 lb ft
38.1 mm	1-1/2 in	1-7/8-12 in	285 - 338 Nm	210 - 250 lb ft

**Straight threads with O-ring**

Tube outside diameter/Hose inside diameter		Thread size	Nm	lb in/lb ft
mm	inch			
6.4 mm	1/4 in	7/16-20 in	16 - 26 Nm	144 - 228 lb in
7.9 mm	5/16 in	1/2-20 in	22 - 34 Nm	192 - 300 lb in
9.5 mm	3/8 in	9/16-18 in	34 - 54 Nm	300 - 480 lb in
12.7 mm	1/2 in	3/4-16 in	57 - 91 Nm	540 - 804 lb in
15.9 mm	5/6 in	7/8-14 in	79 - 124 Nm	58 - 92 lb ft
19.0 mm	3/4 in	1-1/16-12 in	108 - 174 Nm	80 - 128 lb ft
22.2 mm	7/8 in	1-3/16-12 in	136 - 216 Nm	100 - 160 lb ft
25.4 mm	1 in	1-5/16-12 in	159 - 253 Nm	117 - 187 lb ft
31.8 mm	1-1/4 in	1-5/8-12 in	224 - 357 Nm	165 - 264 lb ft
38.1 mm	1-1/2 in	1-7/8-12 in	339 - 542 Nm	250 - 400 lb ft

**Split flange mounting bolts**

Size	Nm	lb in/lb ft
5/16-18 in	20 - 27 Nm	180 - 240 lb in
3/8-16 in	27 - 34 Nm	240 - 300 lb in
7/16-14 in	47 - 61 Nm	420 - 540 lb in
1/2-13 in	74 - 88 Nm	55 - 65 lb ft
5/8-11 in	190 - 203 Nm	140 - 150 lb ft

**O-ring face seal end**

Nominal SAE dash size	Tube outside diameter		Thread size	Nm	lb in/lb ft
	mm	in			
-4	6.4 mm	1/4 in	9/16-18 in	14 - 16 Nm	120 - 144 lb in
-6	9.5 mm	3/8 in	11/16-16 in	24 - 27 Nm	216 - 240 lb in
-8	12.7 mm	1/2 in	13/16-16 in	43 - 54 Nm	384 - 480 lb in
-10	15.9 mm	5/8 in	1-14 in	62 - 76 Nm	552 - 672 lb in
-12	19.0 mm	3/4 in	1-3/16-12 in	90 - 110 Nm	65 - 80 lb ft
-14	22.2 mm	7/8 in	1-3/16-12 in	90 - 110 Nm	65 - 80 lb ft
-16	25.41 mm	1.0 in	1-7/16-12 in	125 - 140 Nm	92 - 105 lb ft
-20	31.8 mm	1-1/4 in	1-11/16-12 in	170 - 190 Nm	125 - 140 lb ft
-24	38.1 mm	1-1/2 in	2-12 in	200 - 254 Nm	150 - 180 lb ft

INTRODUCTION

O-ring boss end fitting or lock nut

Nominal SAE dash size	Tube outside diameter		Thread size	Nm	lb in/lb ft
	mm	in			
-4	6.4 mm	1/4 in	7/16-20 in	23 - 27 Nm	204 - 240 lb in
-6	9.5 mm	3/8 in	9/16-18 in	34 - 41 Nm	300 - 360 lb in
-8	12.7 mm	1/2 in	3/4-16 in	61 - 68 Nm	540 - 600 lb in
-10	15.9 mm	5/8 in	7/8-14 in	81 - 88 Nm	60 - 65 lb ft
-12	19.0 mm	3/4 in	1-1/16-12 in	115 - 122 Nm	85 - 90 lb ft
-14	22.2 mm	7/8 in	1-13/16-12 in	129 - 136 Nm	95 - 100 lb ft
-16	25.41 mm	1.0 in	1-5/16-12 in	156 - 169 Nm	115 - 125 lb ft
-20	31.8 mm	1-1/4 in	1-5/6-12 in	201 - 217 Nm	150 - 160 lb ft
-24	38.1 mm	1-1/2 in	1-7/8-12 in	258 - 271 Nm	190 - 200 lb ft

## Abbreviation Measurements

Typical applications	Metric unit		Imperial unit	
	Name	Symbol	Name	Symbol
Area (Land area)				
	hectare	ha	acre	ac
	square meter	m <sup>2</sup>	square foot	ft <sup>2</sup>
			square inch	in <sup>2</sup>
	square millimeter	mm <sup>2</sup>	square inch	in <sup>2</sup>
Electricity				
	ampere	A	ampere	A
	volt	V	volt	V
	microfarad	μF	microfarad	μF
	ohm	Ω	ohm	Ω
Force				
	kilonewton	kN	pound	lb
	newton	N	pound	lb
Force per length				
	newton per meter	N/m	pound per foot	lb/ft
			pound per inch	lb/in
Frequency				
	megahertz	MHz	megahertz	MHz
	kilohertz	kHz	kilohertz	kHz
	hertz	Hz	hertz	Hz
Frequency - Rotational				
	revolution per minute	r/min	revolution per minute	r/min <sup>a</sup>
		rpm		rpm
Length				
	kilometer	km	mile	mi
	meter	m	foot	ft
	centimeter	cm	inch	in
	millimeter	mm	inch	in
	micrometer	μm		
Mass				
	kilogram	kg	pound	lb
	gram	g	ounce	oz
	milligram	mg		
Power				
	kilowatt	kW	horsepower	Hp
	watt	W	Btu per hour	Btu/hr
			Btu per minute	Btu/min
Pressure or stress (Force per area)				
	kilopascal	kPa	pound per square inch	psi
			inch of mercury	inHg
	pascal	Pa	inch of water	inH <sub>2</sub> O
	megapascal	MPa	pound per square inch	psi

INTRODUCTION

Typical applications	Metric unit		Imperial unit	
	Name	Symbol	Name	Symbol
Temperature (other than Thermodynamic)				
	degrees Celsius	°C	degrees Fahrenheit	°F
Time				
	hour	<b>h</b>	hour	<b>h</b>
	minute	<b>min</b>	minute	<b>min</b>
	second	<b>s</b>	second	<b>s</b>
Torque (includes Bending moment, Moment of force, and Moment of a couple)				
	newton meter	<b>N m</b>	pound foot	<b>lb ft</b>
			pound foot	<b>lb in</b>
Velocity				
	kilometer per hour	<b>km/h</b>	mile per hour	<b>mph</b>
	meter per second	<b>m/s</b>	foot per second	<b>ft/s</b>
	millimeter per second	<b>mm/s</b>	inch per second	<b>in/s</b>
	meter per minute	<b>m/min</b>	foot per minute	<b>ft/min</b>
Volume (includes Capacity)				
	cubic meter	<b>mm<sup>3</sup></b>	cubic yard	<b>yd<sup>3</sup></b>
				<b>cu yd</b>
	liter	<b>l</b>	cubic inch	<b>in<sup>3</sup></b>
	liter	<b>l</b>	US gallon	<b>US gal</b>
			UK gallon	<b>UK gal</b>
			US quart	<b>US qt</b>
			UK quart	<b>UK qt</b>
	milliliter	<b>ml</b>	fluid ounce	<b>fl oz</b>
Volume per time (includes Discharge and Flow rate)				
	cubic meter per minute	<b>m<sup>3</sup>/min</b>	cubic foot per minute	<b>ft<sup>3</sup>/min</b>
	liter per minute	<b>l/min</b>	US gallon per minute	<b>US gal/min</b>
	milliliter per minute	<b>ml/min</b>	UK gallon per minute	<b>UK gal/min</b>
Sound power level and Sound pressure level				
	decibel	<b>dB</b>	decibel	<b>dB</b>

---

## Capacities

### Engine crank case

Specification:	Case Akcela No. 1 15W-40, API CI-4/SL
Capacity:	
With filter change	<b>13.6 l (14.4 US qt)</b>

---

### Fuel tank

Specification:	No. 2 diesel
Capacity:	<b>159 l (42 US gal)</b>

---

### Cooling system

Specification:	<b>50 % water and 50 % ethylene glycol</b>
----------------	--

---

Capacity:	
580N	
Without heater	<b>16.1 l (17.0 US qt)</b>
With heater	<b>16.8 l (17.8 US qt)</b>

---

580SN, 580SN-WT, 590SN	
Without heater	<b>17.3 l (18.3 US qt)</b>
With heater	<b>18.0 l (19.0 US qt)</b>

---

### Hydraulic system

Specification:	Case Akcela Hy-Tran® Ultra
----------------	----------------------------

---

Capacity:	
580N	
Total system	<b>106.0 l (112.0 US qt)</b>
Total system with Extendahoe	<b>111.7 l (118.0 US qt)</b>
Reservoir with filter change	<b>47.1 l (12.45 US gal)</b>
Reservoir without filter change	<b>45.2 l (11.95 US gal)</b>

---

580SN	
Total system	<b>119.2 l (126 US qt)</b>
Total system with Extendahoe	<b>124.9 l (132 US qt)</b>
Reservoir with filter change	<b>47.1 l (12.45 US gal)</b>
Reservoir without filter change	<b>45.2 l (11.95 US gal)</b>

---

580SN-WT	
Total system	<b>124.9 l (132 US qt)</b>
Total system with Extendahoe	<b>130.6 l (138.0 US qt)</b>
Reservoir with filter change	<b>47.1 l (12.45 US gal)</b>
Reservoir without filter change	<b>45.2 l (11.95 US gal)</b>

---

590SN	
Total system	<b>132 l (139 US qt)</b>
Total system with Extendahoe	<b>137.7 l (145 US qt)</b>
Reservoir with filter change	<b>47.1 l (12.45 US gal)</b>
Reservoir without filter change	<b>45.2 l (11.95 US gal)</b>

---

## Transmission

Specification: Case Akcela Hy-Tran® Ultra

Capacity:

Manual (powershuttle)

	Two wheel drive	Four wheel drive
Total system	<b>17.0 l (18 US qt)</b>	<b>19.4 l (21 US qt)</b>
Refill (with or without filter change)	<b>10.5 l (11 US qt)</b>	<b>13.0 l (14 US qt)</b>

Powershift S-type

	Two wheel drive	Four wheel drive
Total system	<b>21.7 l (23 US qt)</b>	<b>20.7 l (22 US qt)</b>
Refill (with or without filter change)	<b>15.3 l (16 US qt)</b>	<b>14.3 l (15 US qt)</b>

Powershift H-type

	Four wheel drive only
Total system	<b>18.0 l (19 US qt)</b>
Refill (with or without filter change)	<b>11.4 l (12 US qt)</b>

## Front drive axle - Two wheel drive

Specification: Case Akcela Transaxle SAE 80W140

Capacity:

Each hub **0.8 l (0.8 US qt)**

## Front drive axle - Four wheel drive

Specification: Case Akcela Transaxle SAE 80W140

Capacity:

580N, 580SN

Differential **7.7 l (8.1 US qt)**

Each planetary hub **0.5 l (0.5 US qt)**

580SN-WT, 590SN

Differential **8.6 l (9.1 US qt)**

Each planetary hub **1.0 l (1.1 US qt)**

## Rear axle (differential)

Specification: Case Transaxle Akcela

Capacity:

580N, 580SN **13.6 l (14.4 US qt)**

580SN-WT, 590SN **18.6 l (19.7 US qt)**

## Brake master cylinder

Brake fluid supplied by the transmission.

## Consumables

### Engine oil recommendations

**AKCELA NO. 1 ENGINE OIL 15W-40** is recommended for use in your machine's engine. The recommended oil will lubricate your engine correctly under all operating conditions. If the recommended oil is not available in a multi-viscosity grade engine oil, it is okay to use a single grade engine oil in the recommended oil brand.

If the recommended engine oil is not available in multi-viscosity or single grade, only use oil meeting API engine oil service category CH-4.

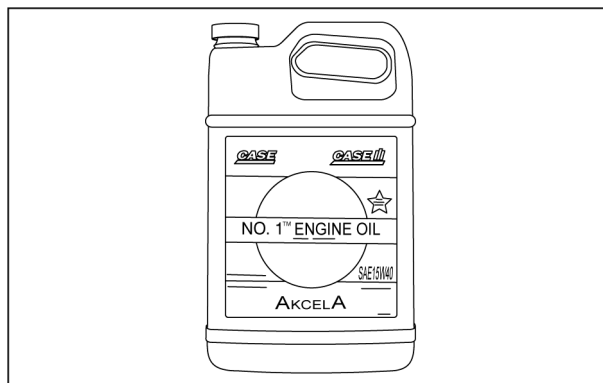

RCPH10TLB244ACL 1

Refer to the chart for recommended viscosity at ambient air temperature ranges.

**NOTE:** Do not put Performance Additives or other oil additive products in the engine crankcase. The oil intervals given in the operators manual and service chart are according to tests with **CASE AKCELA** lubricants.

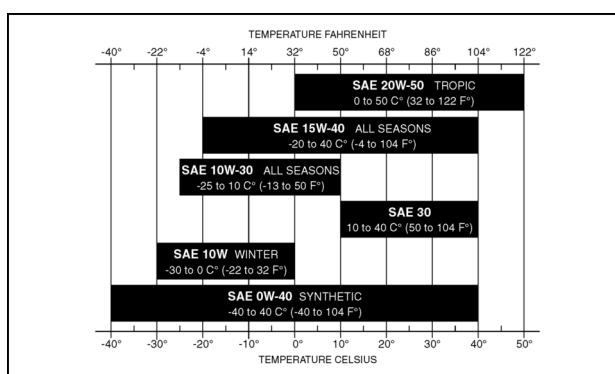

RCPH10TLB022FAL 2

### Dye and black light procedure for detecting oil leaks

Oils and grease have natural phosphors and will illuminate differently under the black light. Oil, bluish-white, grease, brilliant-white, anti-freeze, greenish-yellow, sealing compounds, red to orange.

Kit part number 380040182 consisting of:

Part Number	Description	Unit of measurement	Comments	Usage
380002254	Black Light	—	12 Volt Ultra Violet Light	—
380002357	Dye-uniglow F2HF	10 ml (0.34 US fl oz)	Glowes Green in Black Light	Engine Oil / Crankcase
380002358	Dye-uniglow F4HF	65 ml (2.2 US fl oz)	Glowes Yellow in Black Light	Hydraulic Oil
380002359	Dye-uniglow 1750	10 ml (0.34 US fl oz)	Glowes Purple in Black Light	Transmission Oil

**NOTE:** Each dye is formulated to work in conjunction with a specific fluid, therefore the dyes are not interchangeable and should only be used as described.

## INTRODUCTION

1. Prior to adding dye, connect the black light to the machine's battery and investigate suspected areas.
2. Once suspected leak areas are found, attempt to trace the leak completely to the origin.

**NOTE:** At the origin, the leak should be the brightest in color.

3. After confirmation of the suspected leak, thoroughly clean the area of the leak to remove any existing fluids. Recheck the area with the black light to assure the area is clean. Good cleaning is important for the following reasons:

- Fluids captured by threaded joints or other cavities will continue to show signs of leakage unless completely clean.
- Casting surfaces can hold residual oil.

4. Use the entire contents of the bottle of dye in the system/systems of the suspected leak.
5. Run the unit for 5 to 10 minutes and cycle through suspect system functions to ensure that the dye is available to all possible leak points.

**NOTE:** The hydraulic oil should be heated to 71 °C (160 °F), engine at normal operating temperature, and transmission should be in the normal operating range on the gauge.

6. Use a clean cloth and wipe the dipstick or the inside surface of the filler tube on each of the 3 sumps.
7. View traces of dyed fluid on the cloth under the black light to ensure good samples.
8. Use these 3 samples as your baseline when inspecting the unit with the black light.

**NOTE:** High hour engine oil can reduce the effectiveness of the dye. In this event change the oil.

9. Avoid common errors.
  - Fan airflow blowing leaking fluid.
  - Gravity pulling leak paths down.
  - When paint at a joint is not broken, the joint is not leaking.

**NOTE:** It is not necessary to change oils after this check.

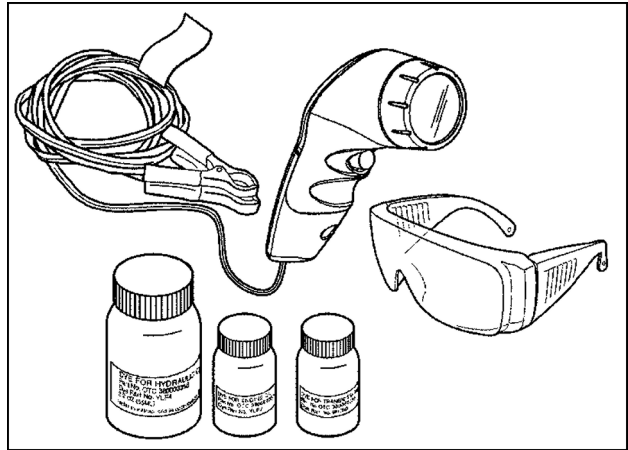

RCPH10TLB245ACL 3

## Diesel fuel

Use No. 2 diesel fuel in the engine of this machine. The use of other fuels can cause the loss of engine power and high fuel consumption.

In very cold temperatures, a mixture of No. 1 and No. 2 diesel fuels is temporarily permitted.

**NOTICE:** See your fuel dealer for winter fuel requirements in your area. If the temperature of the fuel is below the cloud point (wax appearance point), wax crystals in the fuel will cause the engine to lose power or not start.

The diesel fuel used in this machine must meet the specifications in the chart or Specification D975-81 of the American Society for Testing and Materials.

## Fuel Storage

If you keep fuel in storage for a period of time, you can get foreign material or water in the fuel storage tank. Many engine problems are caused by water in the fuel.

Keep the fuel storage tank outside and keep the fuel as cool as possible. Remove water from the storage container at regular periods of time.

Specifications for acceptable No. 2 Diesel Fuel	
API gravity (minimum)	34
Flash point (minimum)	60 °C (140 °F)
* Cloud point (maximum)	-20 °C (-4 °F)
* Pour point (maximum)	-26 °C (-15 °F)
Viscosity (at)	88 °C (190 °F)
Centistokes	(2.0) to (4.3)
Saybolt Seconds Universal	(32) to (40)
* Refer to the Notice on this page.	



## **SERVICE MANUAL**

**HYDRAULIC, PNEUMATIC, ELECTRICAL, ELECTRONIC SYSTEMS**

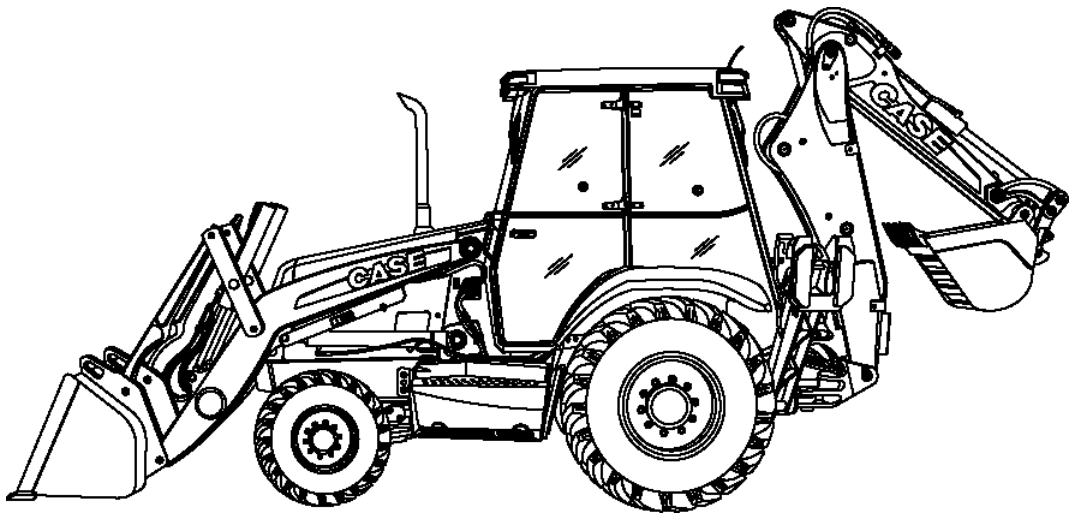

**580N  
580SN WT  
580SN  
590SN**

# Contents

---

## HYDRAULIC, PNEUMATIC, ELECTRICAL, ELECTRONIC SYSTEMS - A

PRIMARY HYDRAULIC POWER SYSTEM.....	A.10.A
580N , 580SN WT , 580SN , 590SN	
SECONDARY HYDRAULIC POWER SYSTEM.....	A.12.A
580N , 580SN WT , 580SN , 590SN	
ELECTRICAL POWER SYSTEM .....	A.30.A
580N , 580SN WT , 580SN , 590SN	
FAULT CODES .....	A.50.A
580N , 580SN WT , 580SN , 590SN	



**Suggest:**

**If the above button click is invalid.**

**Please download this document**

**first, and then click the above link**

**to download the complete manual.**

**Thank you so much for reading**



# **HYDRAULIC, PNEUMATIC, ELECTRICAL, ELECTRONIC SYSTEMS - A**

## **PRIMARY HYDRAULIC POWER SYSTEM - 10.A**

**580N  
580SN WT  
580SN  
590SN**

**<https://www.ebooklibonline.com>**

Hello dear friend!

Thank you very much for reading.

Enter the link into your browser.

The full manual is available for immediate download.

**<https://www.ebooklibonline.com>**