

580LE-SLE-LSP-LPS 590SLE-LSP LOADER BACKHOES TABLE OF CONTENTS

| DIVISION/SECTION | N° SECTION | REFERENCE N° |
|---|------------|--------------|
| 1 GENERAL INFORMATION | | |
| Standard Torque Specifications and Loctite Product Chart | 1001 | 7-79450GB |
| Fluids and Lubricants | 1002 | 7-79461GB |
| 2 ENGINE | | |
| Removing and Installing the Engine and the Radiator | 2000 | 7-79471GB |
| Stall Tests | 2002 | 7-79482GB |
| Engine Specifications | 2402 * | |
| Cylinder Head and Valves | 2415 * | |
| Engine Cylinder Block | 2425 * | |
| Lubrication System | 2445 * | |
| Cooling System | 2455 * | |
| Turbocharger | 2465 * | |
| Turbocharger Failure Analysis | 2565 * | |
| 3 FUEL SYSTEM | | |
| Fuel System and Filters | 3410 * | |
| Fuel Injector | 3413 * | |
| CAV Injection Pump | 3414 * | |
| Bosch Injection Pump | 3415 * | |
| 4 ELECTRICAL SYSTEM | | |
| Removal and Installation of Electrical Components | 4000 | 7-79490GB |
| Electrical Schematics | 4001 | 7-79503GB |
| 580LSP-590LSP Electronic System and Troubleshooting | 4002 | 7-83511GB |
| Battery | 4003 | 7-79510GB |
| Starter Motor | 4004 | 7-79520GB |
| Instrument Cluster | 4005 | 7-79530GB |
| Alternator | 4007 | 7-79540GB |
| 5 STEERING | | |
| Removing and Installing the Steering Components | 5000 | 7-79551GB |
| Steering Specifications, Pressure Checks and Troubleshooting (580LE) | 5001 | 7-79561GB |
| Steering Specifications, Pressure Checks and Troubleshooting (580SLE) | 5001 | 7-79571GB |
| Steering Control Valve (Orbitrol), EATON Type | 5002 | 7-79580GB |
| Rotary Control Valve (Orbitrol), DANFOSS Type | 5002 | 7-27460GB |
| Steering Cylinders | 5003 | 7-79590GB |
| Front Axle, Two Wheel Drive Machines | 5005 | 7-79600GB |
| Front Axle, Four Wheel Drive Machines | 5006 | 7-79611GB |

*Refer to the Engine Service Manual

Reprinted

6 TRANSMISSION

| | | |
|---|------|-------------|
| Removal and Installation of Transmission Components (CARRARO) | 6000 | 7-27560GB |
| Removal and Installation of CLARK (Powershift) Transmission | 6000 | 7-27570GB |
| Transmission Specifications, Pressure Checks and Troubleshooting (CARRARO) | 6002 | 7-79631GB |
| Transmission Specifications, Pressure Checks and Troubleshooting (CLARK) | 6002 | 7-84330GB |
| Wheels and Tires | 6003 | 7-79640GB |
| Rear Axle and Planetaries | 6004 | 7-79650R1GB |
| Rear Axle and Planetary (Standard)..... | 6004 | 7-27300GB |
| Rear Axle and Planetary (Powershift) | 6004 | 7-27310GB |
| Gearbox (CARRARO) | 6007 | 7-79660GB |
| CLARK Powershift Transmission | 6007 | 7-83631GB |

7 BRAKES

| | | |
|---|------|-----------|
| Removing and Installing the Braking System Components | 7000 | 7-79671GB |
| Master-Cylinder | 7003 | 7-79680GB |

8 HYDRAULIC SYSTEM

| | | |
|--|------|-----------|
| Removing and Installing the Components of the Hydraulic System..... | 8001 | 7-79690GB |
| Hydraulic System Specifications, Troubleshooting and Pressure Checks (580LE)..... | 8002 | 7-79701GB |
| Hydraulic System Specifications, Troubleshooting and Pressure Checks (580SLE) | 8002 | 7-79711GB |
| Cleaning the Hydraulic System | 8003 | 7-79720GB |
| Hydraulic Pump (580LE) | 8004 | 7-79731GB |
| Hydraulic Pump (580SLE)..... | 8004 | 7-79741GB |
| Loader Control Valve..... | 8005 | 7-79751GB |
| Cylinders | 8006 | 7-79760GB |
| Backhoe Attachment Control Valve Block (580LE) | 8007 | 7-79771GB |
| Backhoe Attachment Control Valve Block (580SLE)..... | 8007 | 7-79781GB |
| Auxiliary Control Valve | 8008 | 7-79790GB |
| Accumulator for Machines Fitted with Ride Control System (Optional) | 8009 | 7-83520GB |
| Solenoid Valves for Machines Equipped with Ride Control System (Optional) | 8010 | 7-83530GB |
| Sideshift Carriage Locking Cylinder | 8011 | 7-21090GB |
| Boom Safety Valve | 8012 | 7-27290GB |
| Dipper Safety Valve | 8013 | 7-27320GB |
| Loader Arm Safety Valve | 8014 | 7-27330GB |
| Swing Sequence Valve | 8020 | 7-21010GB |

9 CHASSIS/ATTACHMENT

| | | |
|---|--------|------------|
| Pedals and Levers | 9001 | 7-79801GB |
| Air Conditioning Troubleshooting for Systems with R-134a Refrigerant | 9002 | 7-79810GB |
| Air Conditioning Pressure Gauges and Checks for Systems Using R-134a Refrigerant | 9003 | 7-79820GB |
| Air Conditioning System Maintenance for Systems Using Refrigerant R-134a | 9004 | 7-79830GB |
| Servicing Components of Air Conditioning System Using R-134a Refrigerant | 9005 | 7-79840GB |
| Loader | 9006 | 7-79850GB |
| Cab with ROPS and Safety Frame with ROPS | 9007 | 7-27580GB |
| Backhoes Attachment | 9008 | 7-79870GB |
| Seat and Safety Belt | 9009 | ██████████ |
| Large Format Hydraulic and Electrical Schematics..... | Pocket | ██████████ |

██████████ Section to be distributed at a later date.

<https://www.ebooklibonline.com>

Hello dear friend!

Thank you very much for reading.

Enter the link into your browser.

The full manual is available for immediate download.

<https://www.ebooklibonline.com>

Section 1001

STANDARD TORQUE SPECIFICATIONS AND LOCTITE PRODUCT CHART

TABLE OF CONTENTS

TORQUE SPECIFICATIONS - DECIMAL HARDWARE 2
 TORQUE SPECIFICATIONS - METRIC HARDWARE 3
 TORQUE SPECIFICATIONS - STEEL HYDRAULIC FITTINGS 4-5
 LOCTITE PRODUCT CHART 6

TORQUES SPECIFICATIONS (DECIMAL HARDWARE)

Use the torques in this chart when special torques are not given. These torques apply to fasteners with both UNC and UNF threads as received from suppliers dry, or when lubricated with engine oil. Not applicable if special graphities, Molydisulfide greases, or other extreme pressure lubricants are used.

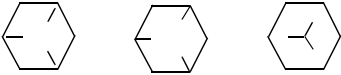
| Grade 5 Bolts, Nuts and Studs | | |
|---|---------------------|----------------------|
|  | | |
| Size | Pound-inches | Newton metres |
| 1/4 inch | 108 to 132 | 12 to 15 |
| 5/16 inch | 204 to 252 | 23 to 28 |
| 3/8 inch | 420 to 504 | 48 to 57 |
| 7/16 inch | 54 to 64 | 73 to 87 |
| 1/2 inch | 80 to 96 | 109 to 130 |
| 9/16 inch | 110 to 132 | 149 to 179 |
| 5/8 inch | 150 to 180 | 203 to 244 |
| 3/4 inch | 270 to 324 | 366 to 439 |
| 7/8 inch | 400 to 480 | 542 to 651 |
| 1.0 inch | 580 to 696 | 787 to 944 |
| 1-1/8 inchs | 800 to 880 | 1085 to 1193 |
| 1-1/4 inchs | 1120 to 1240 | 1519 to 1681 |
| 1-3/8 inchs | 1460 to 1680 | 190 to 2278 |
| 1-1/2 inchs | 1940 to 2200 | 2631 to 2983 |

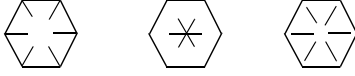
| Grade 8 Bolts, Nuts and Studs | | |
|--|---------------------|----------------------|
|  | | |
| Size | Pound-inches | Newton metres |
| 1/4 inch | 144 to 180 | 16 to 20 |
| 5/16 inch | 288 to 348 | 33 to 39 |
| 3/8 inch | 540 to 648 | 61 to 73 |
| 7/16 inch | 70 to 84 | 95 to 114 |
| 1/2 inch | 110 to 132 | 149 to 179 |
| 9/16 inch | 160 to 192 | 217 to 260 |
| 5/8 inch | 220 to 264 | 298 to 358 |
| 3/4 inch | 380 to 456 | 515 to 618 |
| 7/8 inch | 600 to 720 | 814 to 976 |
| 1.0 inch | 900 to 1080 | 1220 to 1465 |
| 1-1/8 inchs | 1280 to 1440 | 1736 to 1953 |
| 1-1/4 inchs | 1820 to 2000 | 2468 to 2712 |
| 1-3/8 inchs | 2380 to 2720 | 3227 to 3688 |
| 1-1/2 inchs | 3160 to 3560 | 4285 to 4827 |

NOTE : Use thick nuts with Grade 8 bolts.

TORQUE SPECIFICATIONS (METRIC HARDWARE)

Use the following torques when specifications are not given.

These values apply to fasteners with coarse threads as received from supplier, plated or unplated, or when lubricated with engine oil. These values do not apply if graphite or Molydisulfide grease or oil is used.

| Grade 8.8 Bolts, Nuts and Studs | | |
|---|--------------------------|--------------------------|
|  | | |
| Size | Pound- inches | Newton metres |
| M4 | 24 to 36 | 3 to 4 |
| M5 | 60 to 72 | 7 to 8 |
| M6 | 96 to 108 | 11 to 12 |
| M8 | 228 to 276 | 26 to 31 |
| M10 | 456 to 540 | 52 to 61 |
| M12 | 66 to 79 | 90 to 107 |
| M14 | 106 to 127 | 144 to 172 |
| M16 | 160 to 200 | 217 to 271 |
| M20 | 320 to 380 | 434 to 515 |
| M24 | 500 to 600 | 675 to 815 |
| M30 | 920 to 1100 | 1250 to 1500 |
| M36 | 1600 to 1950 | 2175 to 2600 |

| Grade 10.9 Bolts, Nuts and Studs | | |
|---|--------------------------|--------------------------|
|  | | |
| Size | Pound- inches | Newton metres |
| M4 | 36 to 48 | 4 to 5 |
| M5 | 84 to 96 | 9 to 11 |
| M6 | 132 to 156 | 15 to 18 |
| M8 | 324 to 384 | 37 to 43 |
| M10 | 54 to 64 | 73 to 87 |
| M12 | 93 to 112 | 125 to 150 |
| M14 | 149 to 179 | 200 to 245 |
| M16 | 230 to 280 | 310 to 380 |
| M20 | 450 to 540 | 610 to 730 |
| M24 | 780 to 940 | 1050 to 1275 |
| M30 | 1470 to 1770 | 2000 to 2400 |
| M36 | 2580 to 3090 | 3500 to 4200 |

Grade 12.9 Bolts, Nuts and Studs



Usually the torque values specified for grade 10.9 fasteners can be used satisfactorily on grade 12.9 fasteners.

Section

2000

REMOVING AND INSTALLING THE ENGINE AND THE RADIATOR

TABLE OF CONTENTS

| | |
|--|----|
| SPECIFICATIONS..... | 2 |
| SPECIAL TORQUE SETTINGS..... | 2 |
| TOOLS REQUIRED..... | 2 |
| REMOVING THE RADIATOR..... | 3 |
| REMOVING THE ENGINE..... | 6 |
| RADIATOR INSTALLATION..... | 15 |
| RADIATOR SHROUD..... | 16 |
| FRONT ENGINE MOUNT INSTALLATION..... | 17 |
| INSTALLING THE ENGINE FRONT BRACKET..... | 18 |



WARNING: *This symbol is used in this manual to show important safety messages. Whenever you see this symbol, carefully read the message which follows, since it shows there is a risk of serious injury.*

SPECIFICATIONS

| | |
|------------------------------------|------------------|
| Cooling system capacity : | |
| With heater..... | 16.5 litres |
| Without heater..... | 15.8 litres |
| Thermostat opening | |
| Begins to open..... | 83°C |
| Fully open at..... | 95°C |
| Radiator cap opening pressure..... | 1 bar |
| Coolant solution..... | See Section 1002 |

SPECIAL TORQUE SETTINGS

| | |
|---|--------------|
| Front engine bracket self-locking nuts..... | 41 to 47 Nm |
| Torque converter retaining screws..... | 52 to 57 Nm |
| Engine front bracket retaining screws..... | 89 to 107 Nm |



WARNING: *Boiling coolant solution may escape if the radiator cap is removed while the system is still hot. To remove the cap. First allow the system to cool, then turn the cap to the first notch and wait until there is no more pressure. Then remove the cap.*

TOOLS REQUIRED



T91222

CAS 1690 Engine turn-over tool

REMOVING THE RADIATOR

Put identification tags on all disconnected hoses and wires. Close disconnected hoses and fittings with caps and plugs.

STEP 1

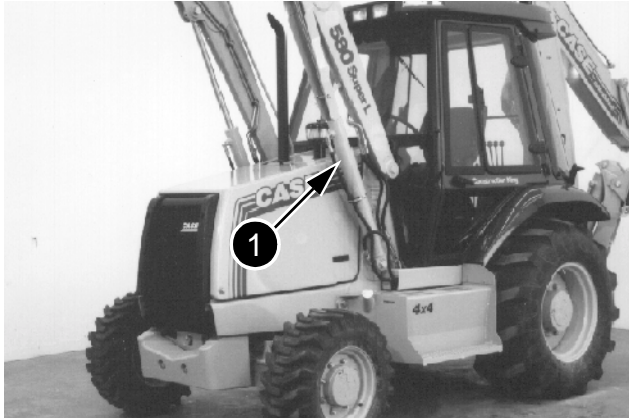

BP9502285

Park the machine on a level surface. Raise the loader attachment, shut down the engine, then install the locking bar (1) to maintain the loader attachment in position.

STEP 2

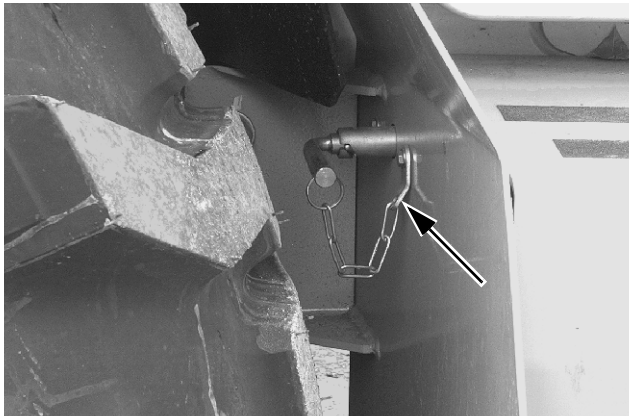

CD95K021

Place the battery master switch in the "Off" position (circuit isolated from battery).

STEP 3

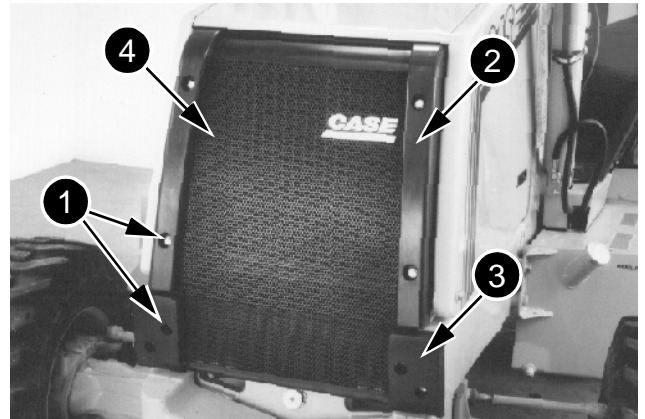

BP9502315

Remove the caps screws (1), upper (2) and lower bumpers (3), and the grille (4) from the front of the machine.

STEP 4

Remove the bolts, washers, and nuts from the pivot point on the hood.

STEP 5

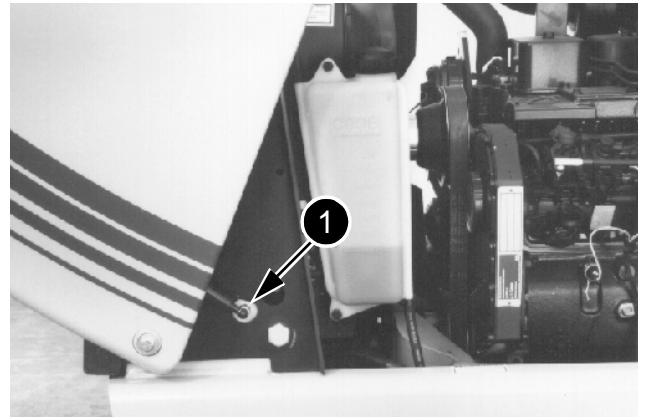

BP9502286

Have another person help with the following procedure:

- A. Open the hood.
- B. Remove the retainers from the hood struts (1) and disconnect the hood struts from the stud.
- C. Hold the hood in place and disconnect the hood cable from the radiator shroud on the other side of the machine.
- D. Carefully lower the hood back to the closed position.

STEP 6



BP9502288

Remove the hood retaining screws. Drive the pivot tubes out of the hood pivot point. Remove the hood from the machine.

STEP 7

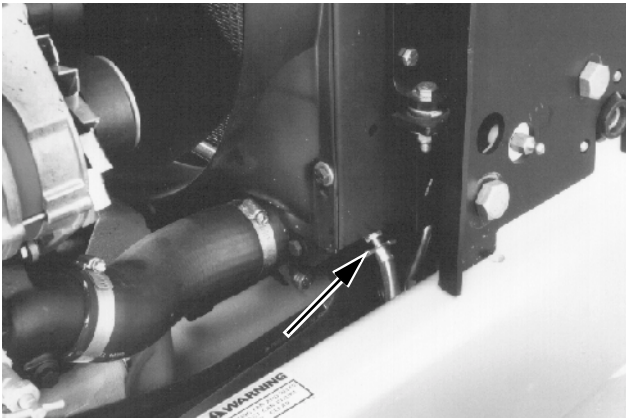

BP9502290

Slowly remove the radiator cap. Install a hose on the drain valve and drain the radiator into a clean container that holds approximately 17 litres. Once the radiator is completely drained, close the drain valve.



WARNING: Do not remove the cap when the engine is hot. The circuit is still under pressure and you could be scalded.

NOTE: During installation, fill the radiator and coolant reservoir completely. See Section 1002 for coolant solution specifications. Start and run the engine until the coolant is at operating temperature. Stop the engine and check for leakage. When the coolant is cold, check the coolant reservoir level. Add coolant as required. Never remove the radiator cap to check the coolant level in the radiator.

STEP 8

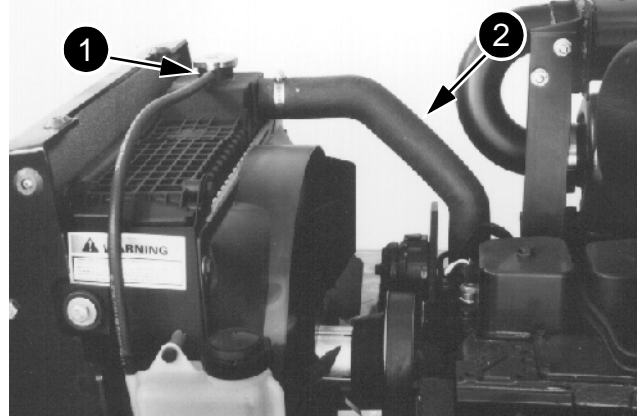

BP9502292

Disconnect the overflow hose (1) from the radiator neck. Loosen the clamp and disconnect the upper radiator hose (2).

STEP 9

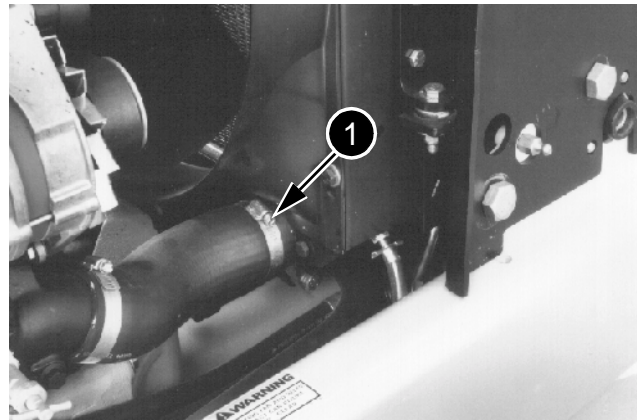

BP9502290

Loosen the clamp (1) and disconnect the lower radiator hose.

STEP 10

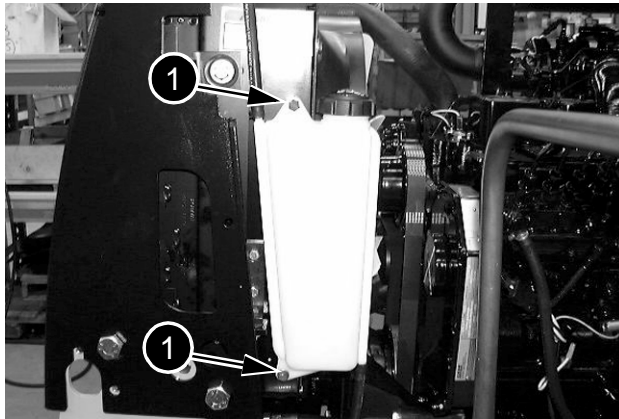

CD00C003

Remove the screws (1), spacers and washers from the coolant solution reservoir, then remove it from the machine.

STEP 11

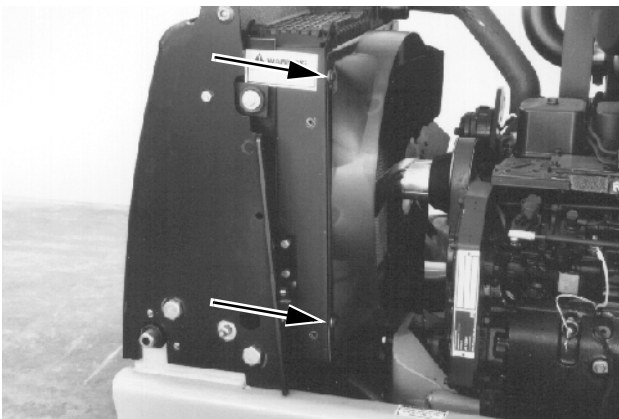

BP9502293

Remove the hardware from the fan shroud. Move the fan shroud away from the radiator.

STEP 12

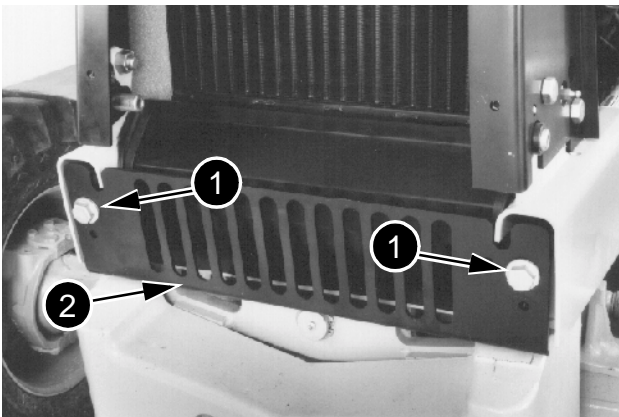

BP9502314

Remove the cap screws (1) and pump guard (2) from the machine.

STEP 13

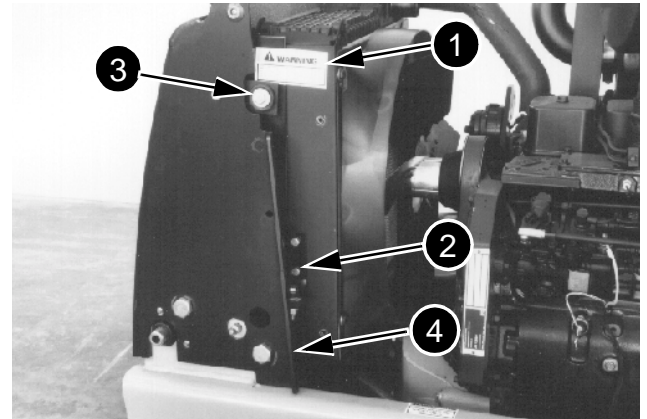

BP9502293

Remove the cap screws that fasten the lower brackets (2) to the radiator. Remove the hardware and the lower brackets (2) from the radiator shroud (1). Remove the cap screws and flat washers that fasten the upper brackets (3) to the radiator. Remove the cap screws and flat washers (4) that fastens the condenser if equipped and oil cooler to the radiator. Lift the radiator straight up and remove the radiator from the machine.

NOTE: *Installation of the radiator is the reverse of removal.*

REMOVING THE ENGINE

Put identification tags on all disconnected hoses and wires. Close disconnected hoses and fittings with caps and plugs.

STEP 1

Carry out Steps 1 to 11 "Radiator Removal".

STEP 2

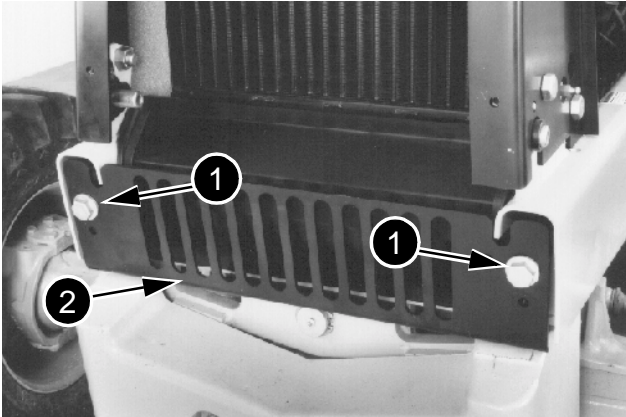

BP9502314

Remove the cap screws (1) and pump guard (2) from the machine.

STEP 3

If a horn is fitted to the machine's deflector, disconnect the cable from the horn.

NOTE: If the machine is equipped with air conditioning and with a baffle plate with a notch provided for the dryer hose, pass on to Step 12. If the machine is equipped with air conditioning and with a baffle plate in which no notch is provided for the dryer hose, carry out Steps 9 to 11 to avoid having to discharge the air conditioning system. For machines without air conditioning, carry out Steps 4 to 8.

STEP 4

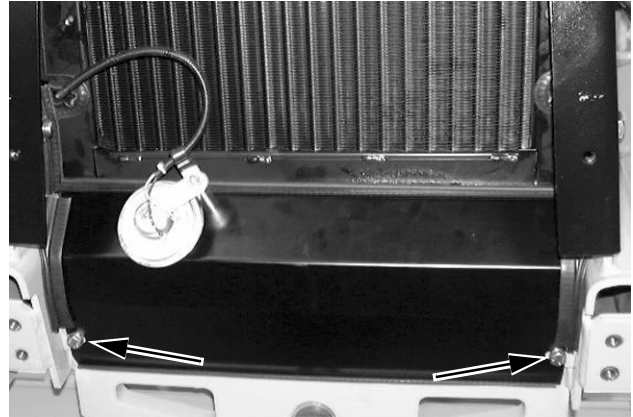

CD00C004

Loosen and remove the cap screws, flat washers, and if equipped, lock washers that fasten the baffle plate to the front of the machine.

STEP 5

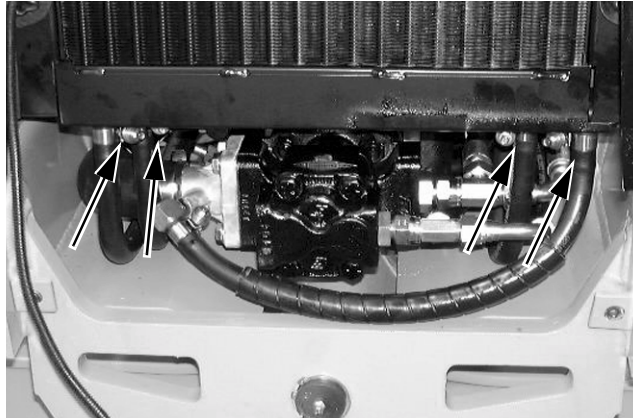

CD00C005

Disconnect the hoses from the oil cooler. Plug the hoses.

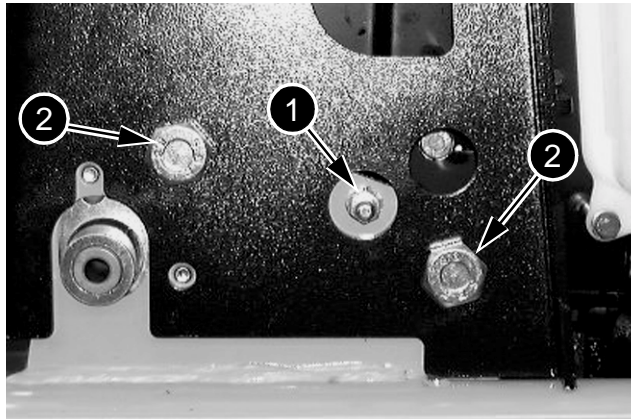
STEP 6

CD00C006

Remove the studs (1). Remove the bolts (2) and nuts that fasten the radiator shroud to the frame.

STEP 7

Remove the radiator shroud, radiator, and oil cooler as an assembly.

STEP 8

Go to Step 23.

NOTE: Do steps 9 to 11 for machine with air conditioning and a baffle plate without a slot.

STEP 9

Remove all straps that hold the hose for the air conditioning system drier from the front of the machine back to the cab. It is important to have as much hose as possible at the front of the machine to do the next step.

STEP 10

Loosen and remove the cap screws, flat washers, and if equipped, lock washers that fasten the baffle plate to the front of the machine.

STEP 11

Move the baffle plate and drier for access to the hoses on the left side of the oil cooler.

STEP 12

Go to Step 15.

NOTE: Do steps 13 and 14 for machines with air conditioning and a baffle plate with a slot.

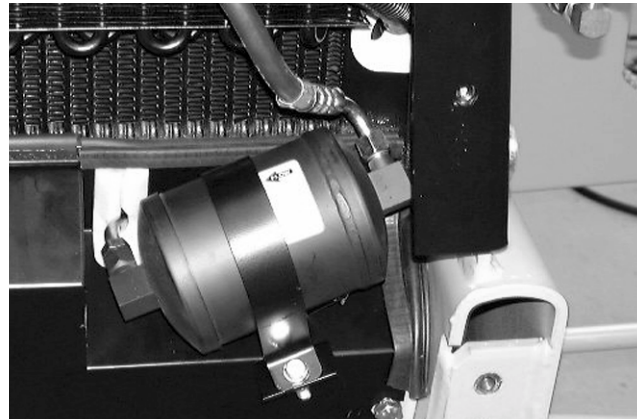
STEP 13

CD00C007

Remove the self-locking nut and the clamp from the dryer.

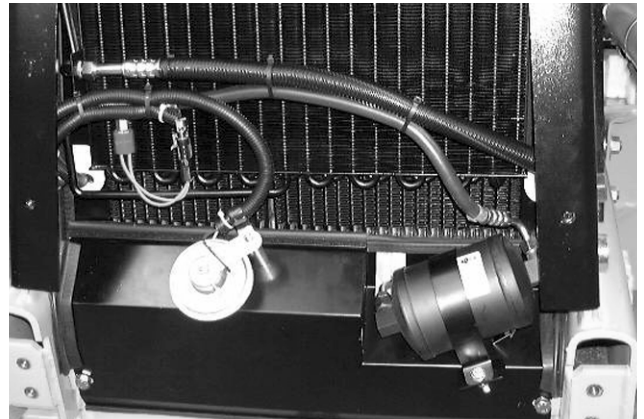
STEP 14

CD00C008

Remove the cap screws, flat washers, and if equipped, lock washers that fasten the baffle plate to the front of the machine. Remove the baffle plate from the dryer and from the machine.

NOTE: Do the remaining steps for all machines.

NOTE: The photo shown below does not correspond to this model of machine, but the procedure is the same.

STEP 15

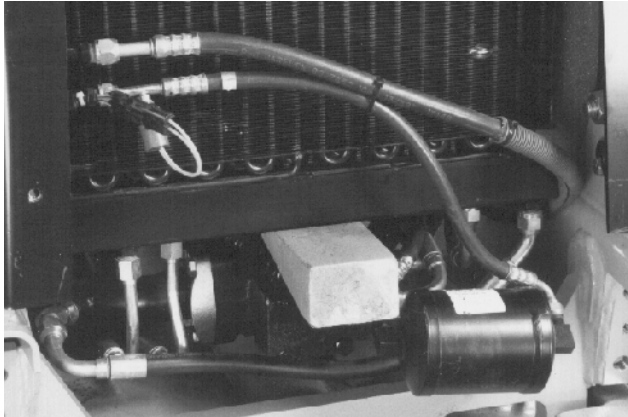

BP9503106

Put a block under the oil cooler to hold the radiator, oil cooler, and condenser in place when the radiator shroud is removed.

STEP 16

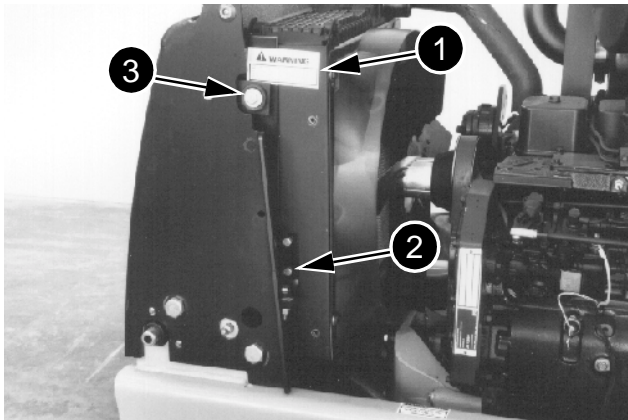

BP9502293

Remove the cap screws that fasten the lower brackets (2) to the radiator (1). Remove the hardware and the lower brackets (2) from the radiator shroud. Remove the cap screws and flat washers that fasten the upper brackets (3) to the radiator.

STEP 17

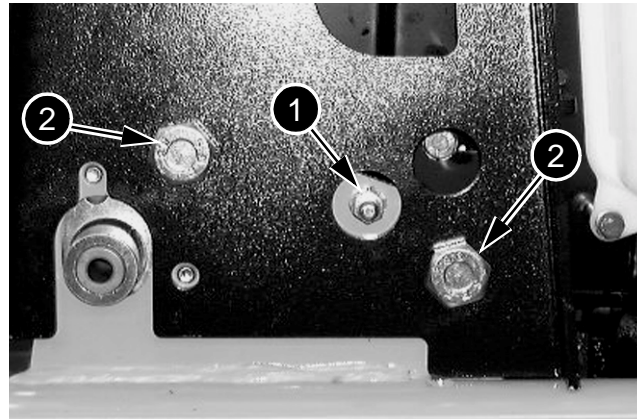

CD00C006

Remove the studs (1) from the frame. Remove the bolts and nuts (2) that fasten the radiator shroud to the frame.

STEP 18

Remove the radiator shroud from the radiator, oil cooler, and condenser.

STEP 19

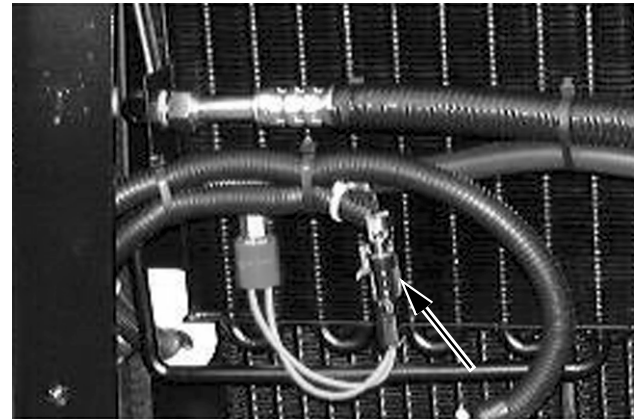

CD00C009

Disconnect the electrical connector for the drier.

STEP 20

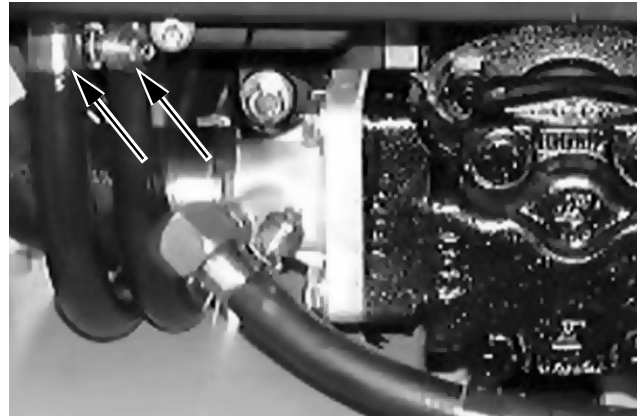

CD00C010

Disconnect the hoses on either side of the oil cooler. Plug the hoses.

STEP 21

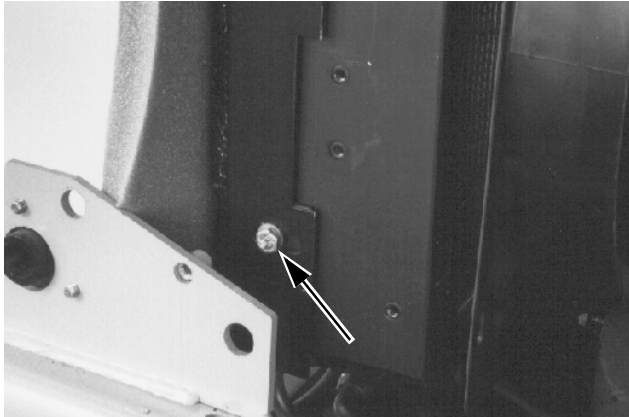

BP9503107

Remove the cap screws and flat washers that fasten the condenser and oil cooler to the radiator.

STEP 22

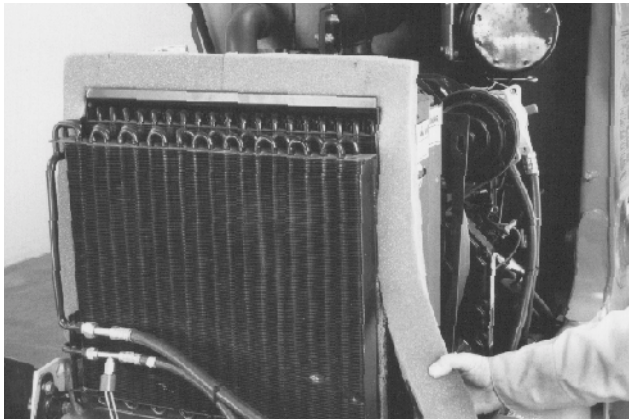

BP9503110

Pull the foam baffle away from the condenser.

STEP 23



BP9503111

For machines with a slot in the baffle plate, move the condenser and drier assembly out of the way as shown. For machines without a slot in the baffle plate, have another person help to move the condenser, baffle plate, and drier assembly away from the radiator and oil cooler assembly. Fasten the assembly in position to the side.

STEP 24

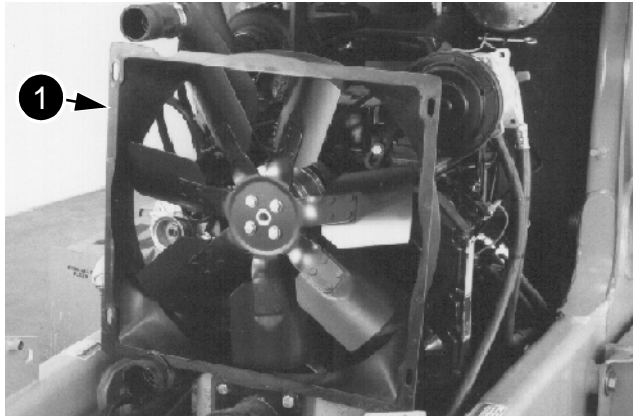

BP9503112

Remove the radiator and oil cooler. Remove the fan shroud (1) from the fan.

STEP 25

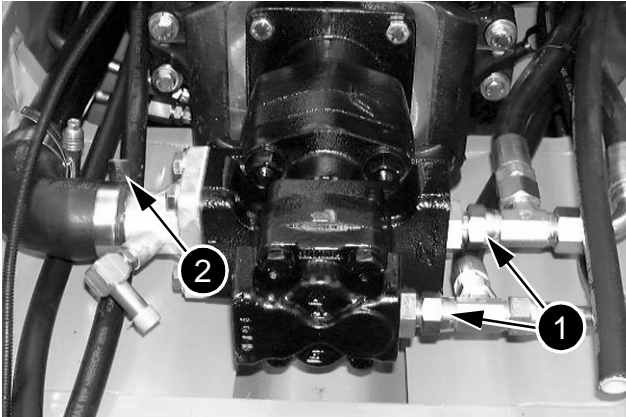

CD00C011

Disconnect the hoses (1) from the LH side of the pump. Loosen the clamp (2) and disconnect the hose from the RH side of the pump.

NOTE: The photo shown below does not correspond to this model of machine, but the procedure is the same.

STEP 26



BP9502311

Loosen and remove the cap screws that fasten the pump to the pump mounting bracket.

NOTE: Do Steps 27 to 29 for machines with air conditioning.

STEP 27

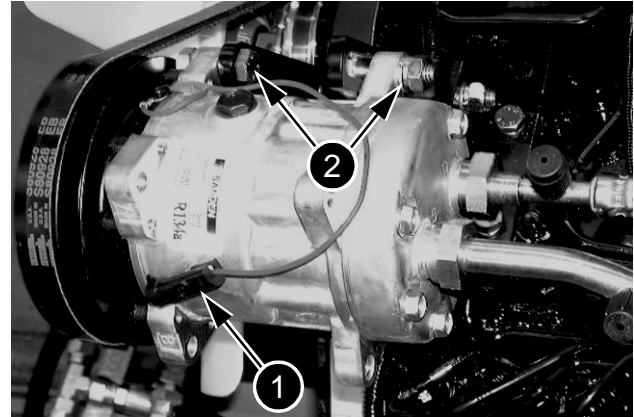

CD00C012

Disconnect the electrical connector (1). Remove the hardware (2) from the adjusting straps.

STEP 28

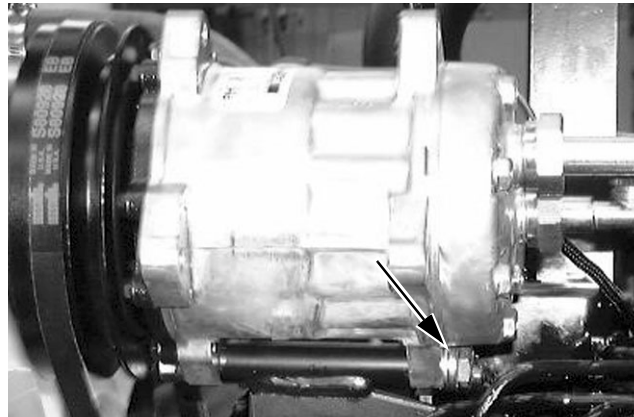

CD00C013

Remove the hardware that fastens the compressor to the bracket.

STEP 29

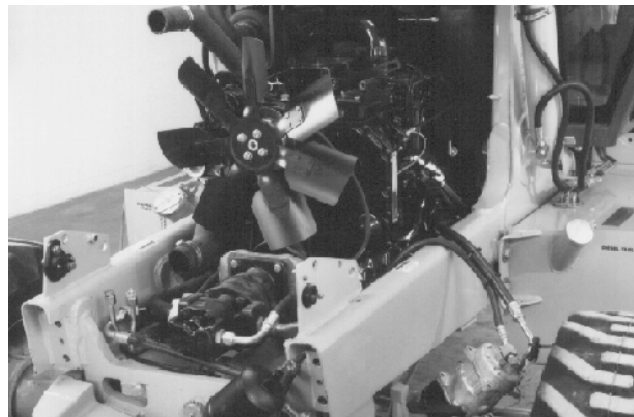

BP9503120

Remove the belt and place the compressor in the position shown in the photograph.

NOTE: During installation, adjust the drive belt according the instructions in Section 9003.

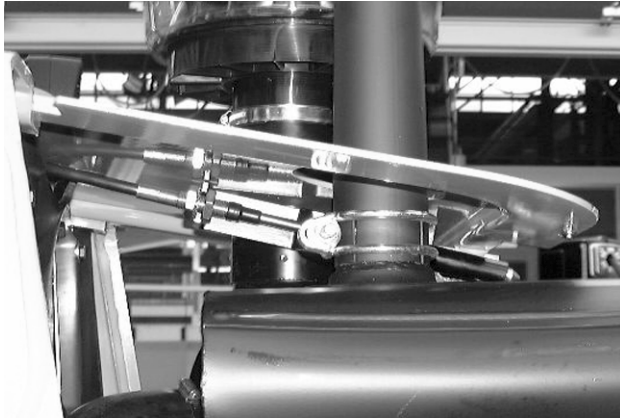
STEP 30

CD00C014

Loosen the clamp for the exhaust pipe at the muffler. Remove the exhaust pipe from the muffler.

NOTE: When installing, tighten the clamp to a torque of between 53 and 61 Nm.

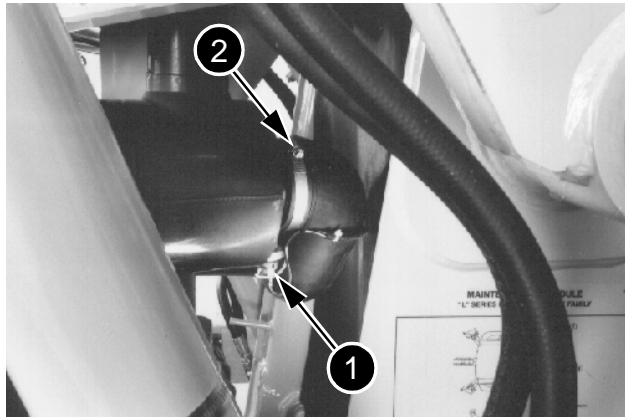
STEP 31

BP9502308

Remove the electrical connectors (1) from the air filter restriction warning lamp. Loosen the air filter hose clamp (2). Disconnect the air filter hose.

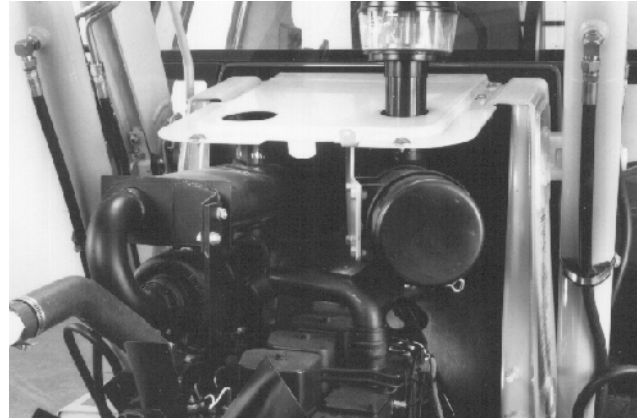
STEP 32

BP9502306

Remove the cap screws and flat washers that fasten the cover to uprights. Remove the cover and air cleaner as an assembly.

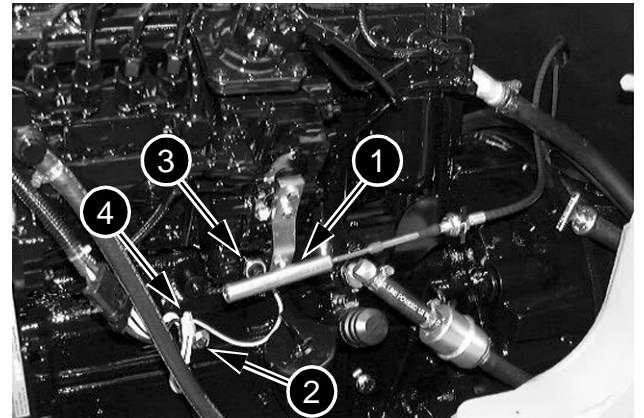
STEP 33

CD00C015

Remove the tie straps (1). Disconnect the wiring harness clamp (2). Disconnect the cable from the oil pressure sender (3). Disconnect the fuel stop cable (4).

STEP 34

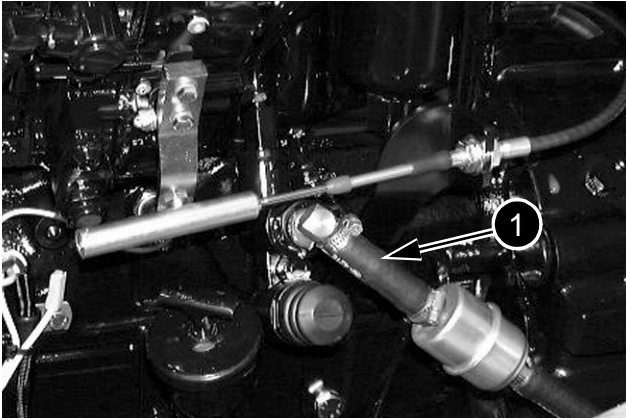

CD00C016

Disconnect the fuel pipe (1) and plug it.

STEP 35

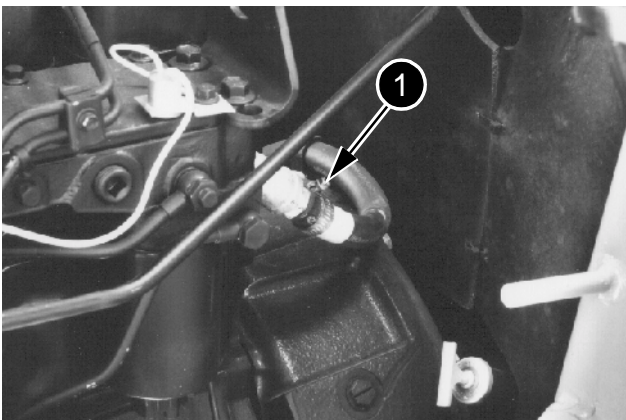

BP9502301

Disconnect and cap the heater hose (1).

STEP 36

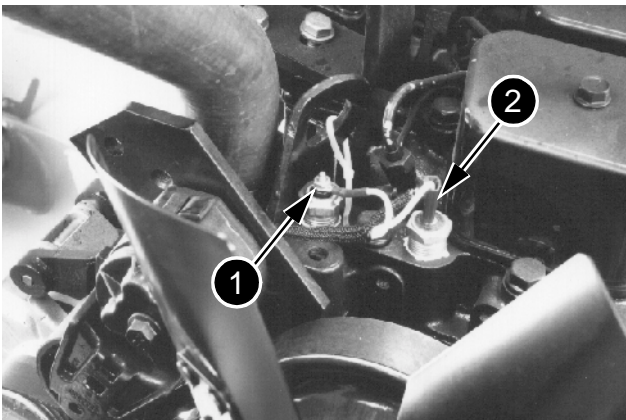

BP9502298

Disconnect the coolant temperature sender (1) and coolant temperature switch (2).

STEP 37

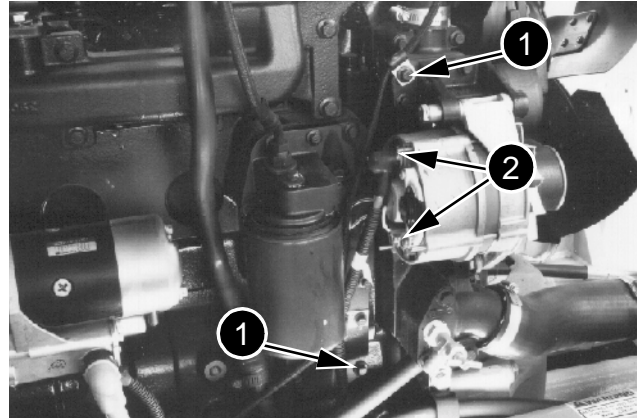

BP9502296

Remove the harness clamps (1). Disconnect the cables (2) from the alternator.

STEP 38

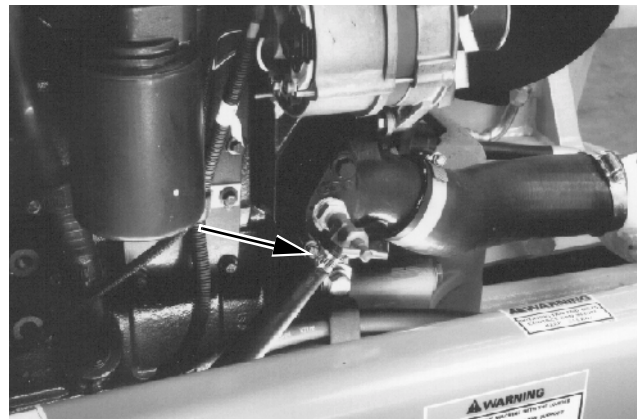

BP9502297

Loosen the clamp. Disconnect and plug the heater hose.

STEP 39

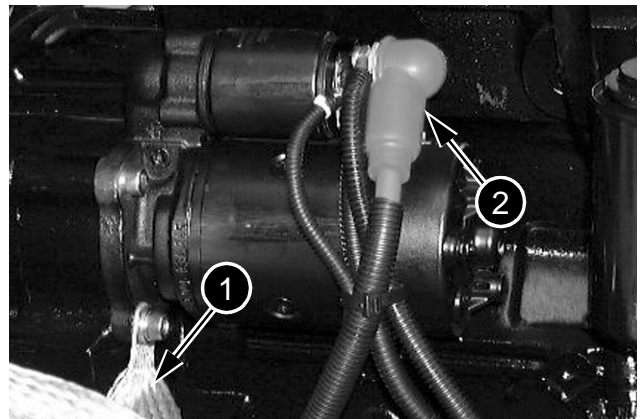

CD00C017

Disconnect the earth strap (1). Put identification tags on the starter cables (2). Disconnect the cables (2).

NOTE: The photo below does not correspond to this model of machine but the procedure is the same.

STEP 40

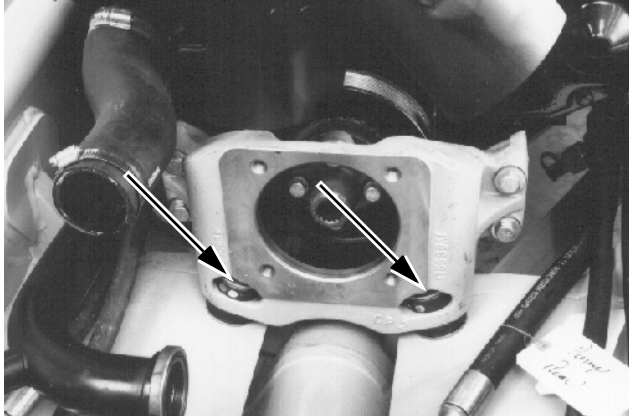

BP9502310

Remove the bolts, flat washers, and nuts from the front engine mount.

NOTE: When installing, tighten the self-locking nuts to a torque of between 41 and 47 Nm.

STEP 41

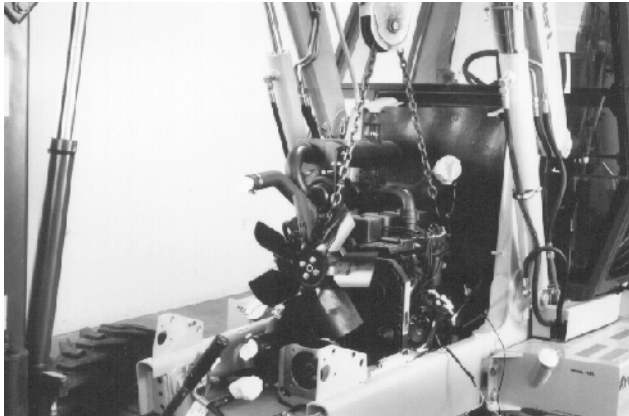

BP9502305

Connect lifting equipment to the lifting eyes on the engine to hold the engine in place.

NOTE: There are six cap screws with lock washers that fasten the torque converter to the flywheel. Rotate the engine to align each cap screw with the access hole in the flywheel housing at the left side of the engine.

STEP 42

Remove the plastic plug from the flywheel housing. Remove the hose from the bracket and remove the cover and gasket from the access hole for the cap screws.

STEP 43

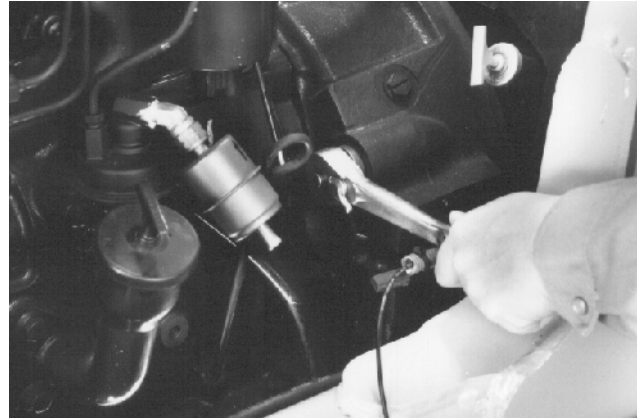

BP9502299

Install the CAS 1690 tool to turn the flywheel.

STEP 44

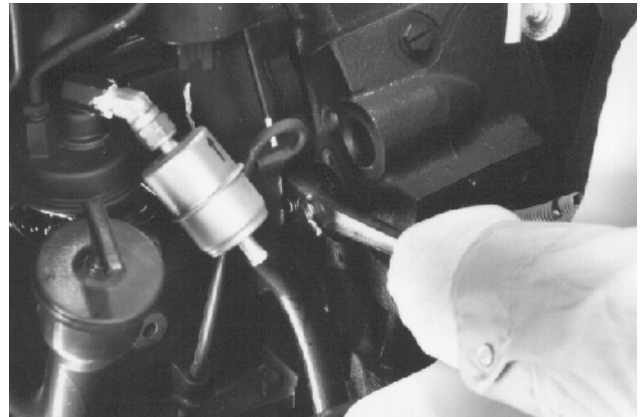

BP9502300

Loosen and remove all six cap screws and washers that fasten the torque converter to the flywheel.

NOTE: Be careful during installation when installing the cap screws and lock washers that fasten the torque converter to the flywheel. Tighten the screws to a torque of between 52 and 57 Nm.

STEP 45

Loosen and remove the 12 cap screws and flat washers that fasten the transmission to the engine. Move the heater hose and clamps out of the way.

STEP 46

Move the engine forward and raise the engine.
Remove the engine from the machine.

NOTE: *Installation of the engine is the reverse of removal. Before starting the engine, do the following:*

1. Fill the turbocharger with oil. Disconnect the fuel shut-off solenoid cable. Operate the starter motor for 1 à 20 seconds to fill the turbo-charger with oil. Connect the wire to the fuel shut-off solenoid.
2. It is essential that the hydraulic pump is filled with oil. Carry out the following procedure to fill the hydraulic pump with oil:
 - A. Make sure that the oil level in the reservoir is correct.
 - B. Remove the cap from the hydraulic reservoir.
 - C. Use a compressed air nozzle to pressurize the hydraulic reservoir. Wrap a cloth around the end of the hose at the nozzle.

NOTE: *34.5 kPa to 69.0 kPa is all that is required to move the oil. Pressure above 69.0 kPa can damage the hydraulic reservoir.*

- D. Have another person start and run the engine at low idle while the hydraulic reservoir is being pressurised.

RADIATOR INSTALLATION

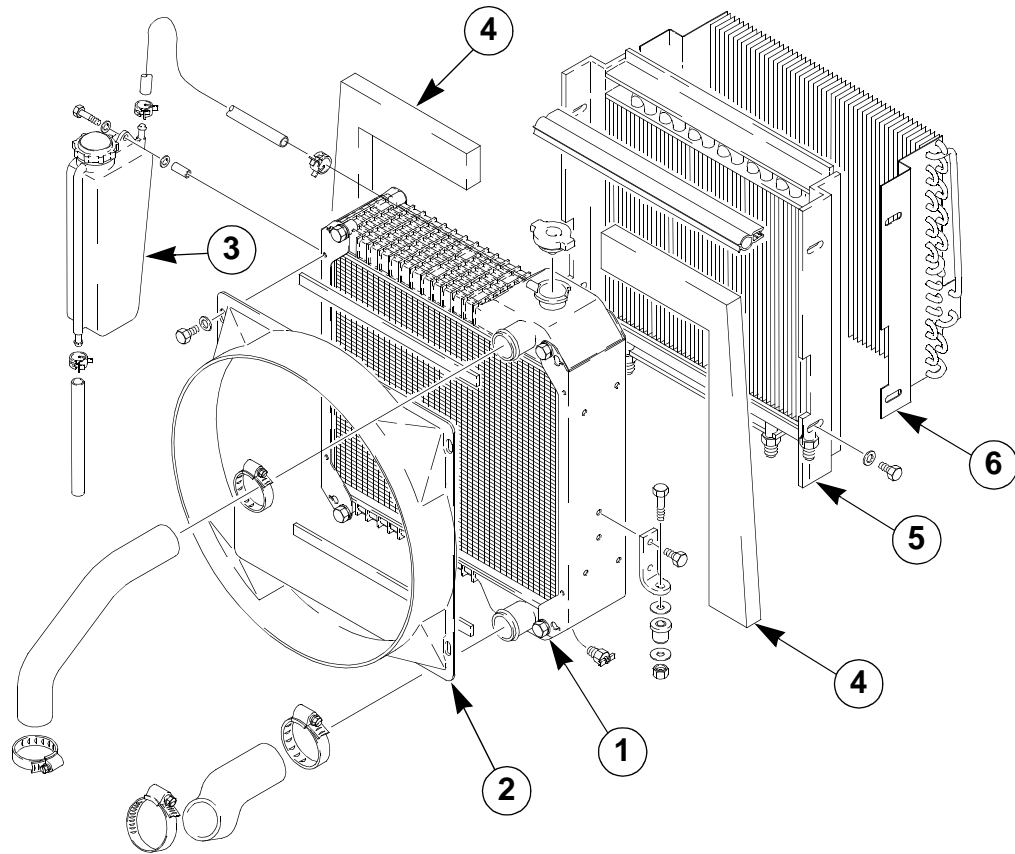

- 1 RADIATOR
- 2 FAN SHROUD
- 3 COOLANT RECOVERY RESERVOIR

- 4 SCREEN
- 5 OIL COOLER
- 6 AIR CONDITIONING CONDENSER

B9503081T

RADIATOR SHROUD

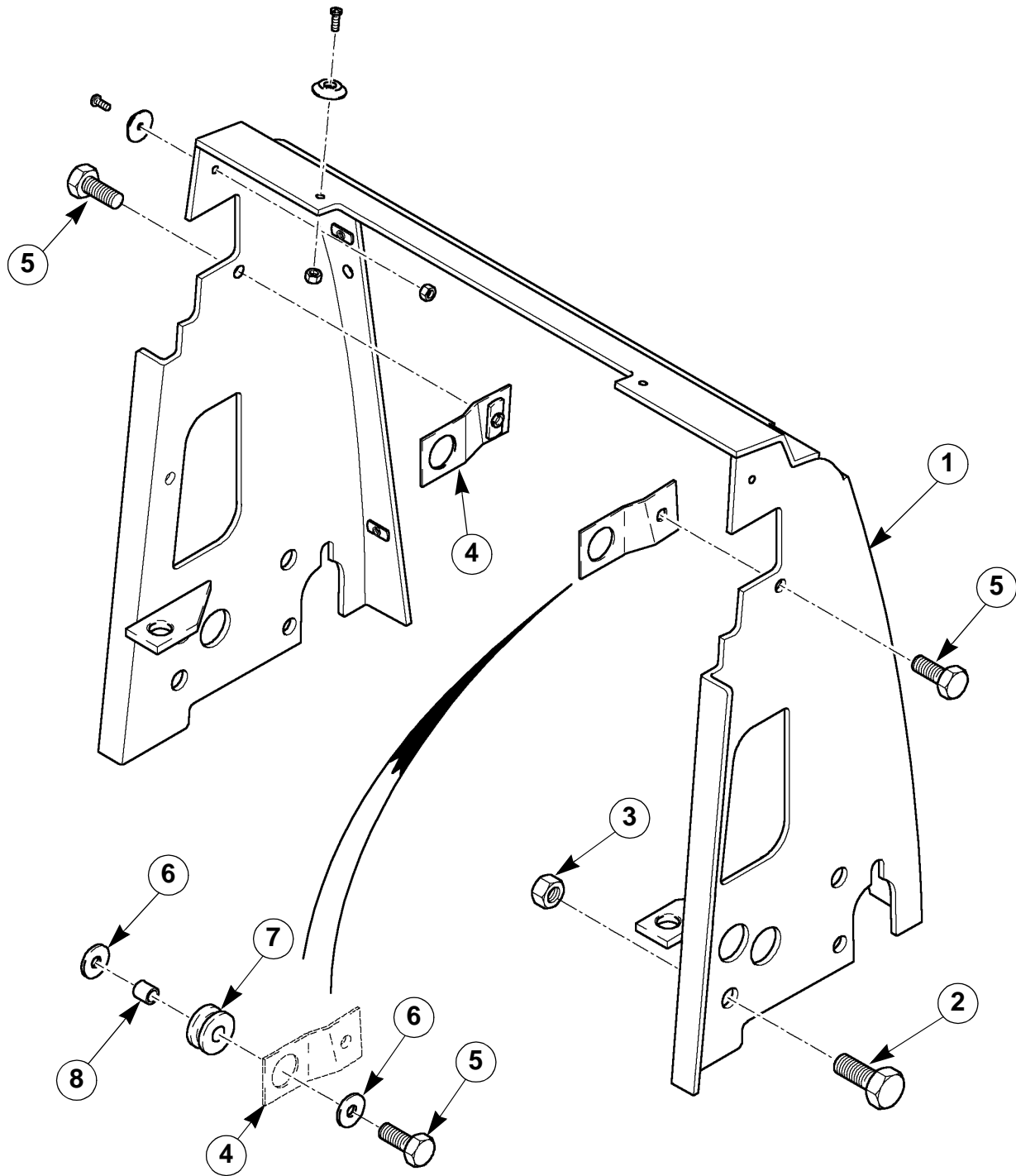

- 1 RADIATOR SHROUD
- 2 SCREWS RETAINING RADIATOR ON MACHINE UNDERCARRIAGE
- 3 NUT
- 4 BRACKET, RADIATOR SHROUD TO RADIATOR

- 5 SCREW
- 6 FLAT WASHER, SPECIAL
- 7 SHOCK ABSORBER
- 8 SPACER

CI00C508

FRONT ENGINE MOUNT INSTALLATION

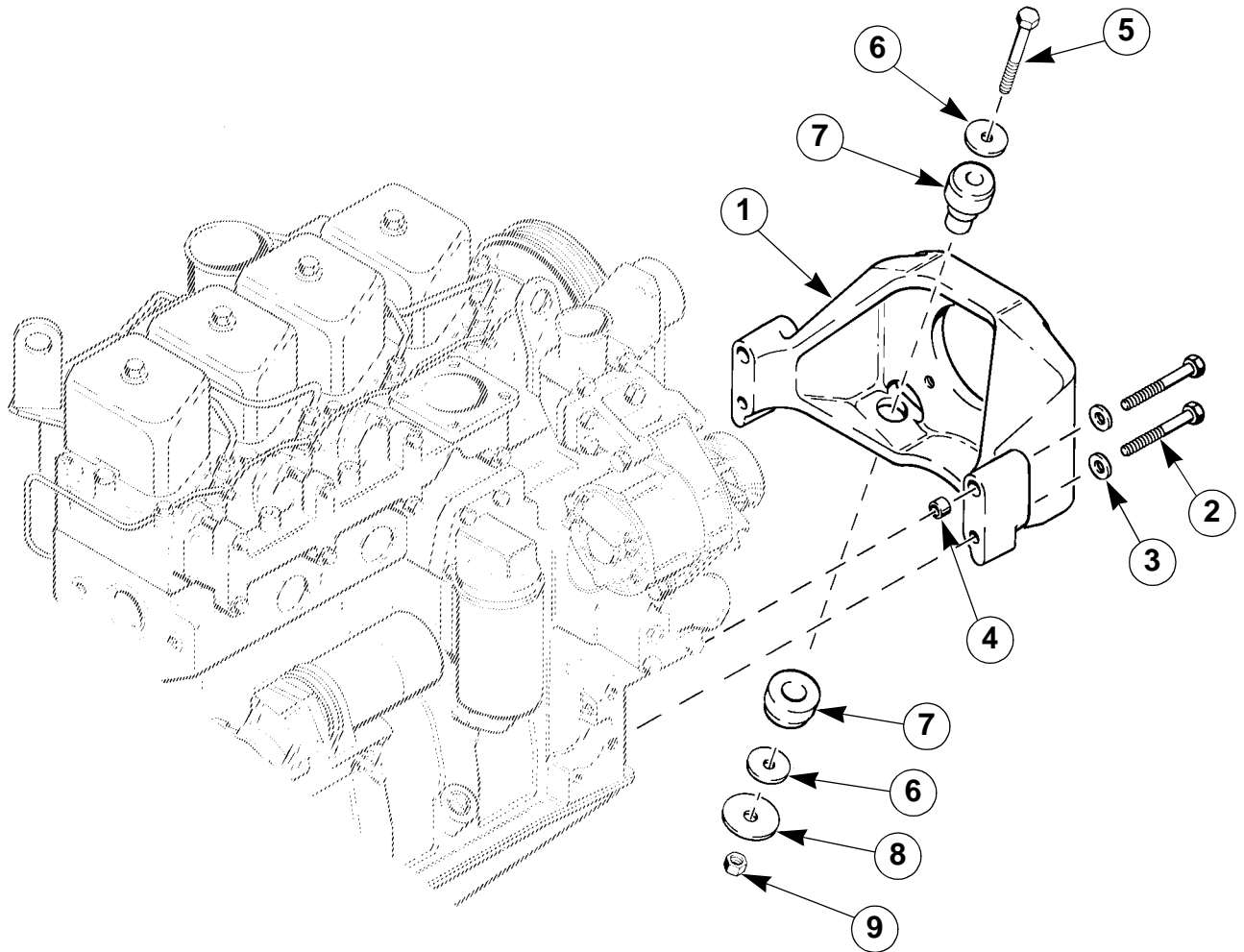

- 1 ENGINE MOUNT
- 2 CAP SCREW
- 3 HARDENED WASHER
- 4 SPACER
- 5 SCREW

- 6 HARDENED WASHER
- 7 GROMMET
- 8 HARDENED WASHER
- 9 SELF-LOCKING NUT

B9503083



Suggest:

If the above button click is invalid.

Please download this document

first, and then click the above link

to download the complete manual.

Thank you so much for reading

INSTALLING THE ENGINE FRONT BRACKET

NOTE: If the front engine support was removed for any reason, the front engine support must be aligned with the crankshaft of the engine. If the front engine support is not aligned with the crankshaft of the engine, the pump can be damaged.

STEP 1

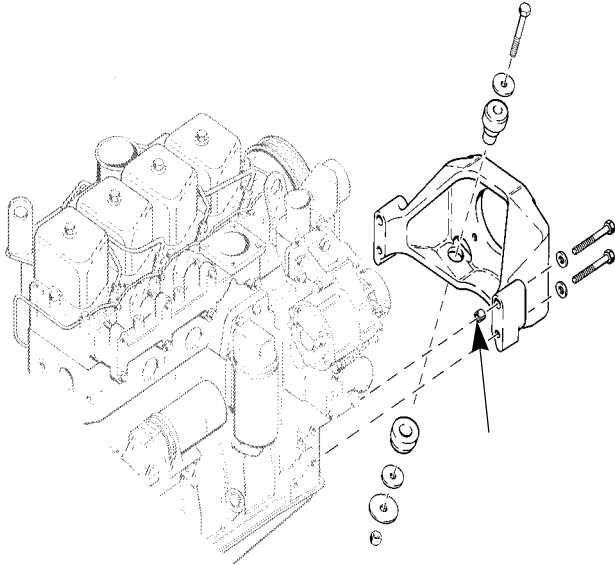

Install a spacer in each top hole in the front engine support. Install the front engine support with the hardware shown.

B9503083

STEP 2

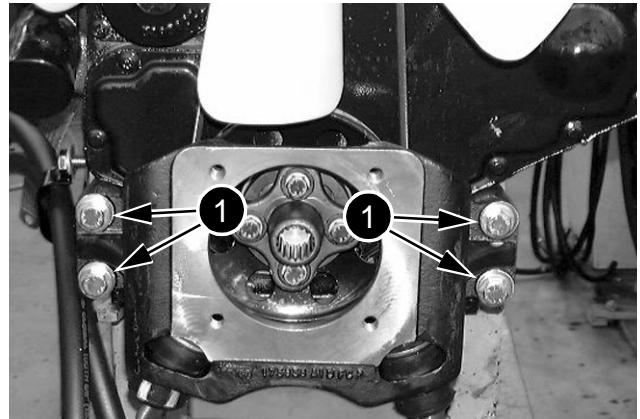

CD00C018

When the front engine support is centred, tighten the screws (1) to a torque of between 89 and 107 Nm.

<https://www.ebooklibonline.com>

Hello dear friend!

Thank you very much for reading.

Enter the link into your browser.

The full manual is available for immediate download.

<https://www.ebooklibonline.com>