

1. Trim along dashed line.
2. Slide into pocket on Binder Spine.

TYPE 1-4

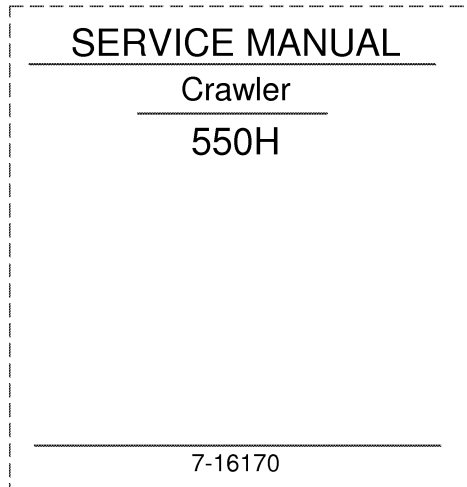

1. Trim along dashed line.
2. Slide into pocket on Binder Spine.

TYPE 1-4

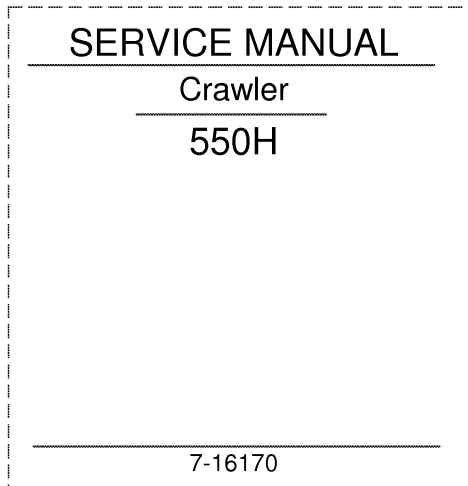

1. Trim along dashed line.
2. Slide into pocket on Binder Spine.

TYPE 1-4

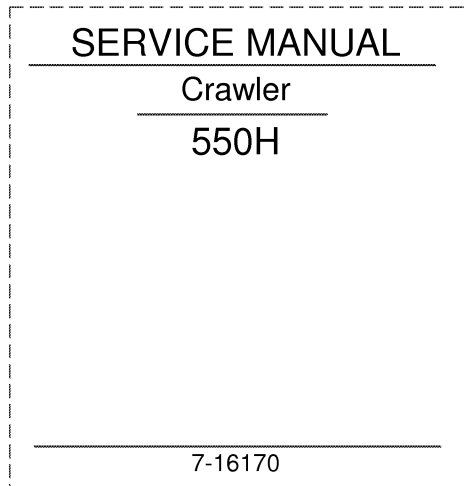

1. Trim along dashed line.
2. Slide into pocket on Binder Spine.

TYPE 1-4

550H CRAWLER

Service Manual 7-16170

Table of Contents

Description	Section No.	Publication Form No.
General	Tab 1	
Section Index - General		7-17600
Standard Torque Specifications	1001	8-71602
Fluids and Lubricants	1002	7-16230
Loctite Product Chart		8-98902
Engines	Tab 2	
Section Index - Engines		7-17610
Stall Tests	2001	7-16240
Radiator and Engine Removal and Installation	2002	7-17820
Fuel System	Tab 3	
Section Index - Fuel System		7-17620
Electrical	Tab 4	
Section Index - Electrical		7-17630
Removal and Installation of Electrical Components	4000	7-17640
Electrical Troubleshooting	4001	7-16250
Battery	4003	8-11361
Instrument Panel	4004	7-17650
Starter and Starter Solenoid	4006	7-17660
Alternator	4007	7-17670
Tracks	Tab 5	
Section Index - Tracks		7-17680
Undercarriage Fundamentals	5001	7-17690
Inspection of Track System Components	5501	7-44140
Case Lubricated Track	5504	7-17700
Sealed Track and Track Frame	5506	7-17710
Rubber Track	5507	7-17720
Idler, Track Adjuster, and Recoil Housing	5508	7-17730
Sprocket	5509	7-17740
Track Roller - 550H and 650H	5511	7-17750
Power Train	Tab 6	
Section Index - Power Train		7-17760
Transmission Removal and Installation	6000	7-17770
Transmission Schematic and Troubleshooting	6002	7-16260
Torque Converter and Torque Converter Housing	6006	7-17780

CASE CORPORATION
700 State Street
Racine, WI 53404 U.S.A.

CASE CANADA CORPORATION
3350 South Service Road
Hamilton, ON L7N 3M6 CANADA

Bur 7-17590

Copyright © 2000 Case Corporation
Printed in U.S.A.
July, 2000

Table of Contents

Description	Section No.	Publication Form No.
Transmission Control Valve	6007	7-17790
Transmission	6016	7-17800
Final Drives	6017	7-17810
Brakes	Tab 7	
Section Index - Brakes		7-17840
Removal and Installation of Brake Valve and Removing Air from Brake System	7001	7-17850
Brake Valve	7002	7-17860
Brakes	7003	7-17870
Hydraulics	Tab 8	
Section Index - Hydraulics		7-17880
Removal and Installation of Hydraulic Components	8001	7-17890
Hydraulic Schematic and Troubleshooting	8002	7-16270
Cleaning the Hydraulic System	8003	7-49640
Equipment Pump	8005	7-17900
Dozer Control Valve	8007	7-16840
Cylinders	8008	7-17910
Mounted Equipment	Tab 9	
Section Index - Mounted Equipment		7-17920
Pedals, Levers, and Linkages	9002	7-16280
Dozer Blade	9007	7-17930
ROPS Canopy, Seat Mounting, and Seat Belts	9008	7-17940
Ripper	9011	7-17970
Schematic Set		
Electrical and Hydraulic Schematic Foldout	In Rear Pocket	7-16290

NOTE: Case Corporation reserves the right to make improvements in design or changes in specifications at any time without incurring any obligation to install them on units previously sold.

<https://www.ebooklibonline.com>

Hello dear friend!

Thank you very much for reading.

Enter the link into your browser.

The full manual is available for immediate download.

<https://www.ebooklibonline.com>

Section 1001

GENERAL TORQUE SPECIFICATIONS

TORQUE SPECIFICATIONS - DECIMAL HARDWARE

Use the torques in this chart when special torques are not given. These torques apply to fasteners with both UNC and UNF threads as received from suppliers dry, or when lubricated with engine oil. Not applicable if special graphities, Molydisulfide greases, or other extreme pressure lubricants are used.

Grade 5 Bolts, Nuts, and Studs		
		
Size	Pound-Inches	Newton metres
1/4 inch	108 to 132	12 to 15
5/16 inch	204 to 252	23 to 28
3/8 inch	420 to 504	48 to 57
Size	Pound-Feet	Newton metres
7/16 inch	54 to 64	73 to 87
1/2 inch	80 to 96	109 to 130
9/16 inch	110 to 132	149 to 179
5/8 inch	150 to 180	203 to 244
3/4 inch	270 to 324	366 to 439
7/8 inch	400 to 480	542 to 651
1.0 inch	580 to 696	787 to 944
1-1/8 inch	800 to 880	1085 to 1193
1-1/4 inch	1120 to 1240	1519 to 1681
1-3/8 inch	1460 to 1680	1980 to 2278
1-1/2 inch	1940 to 2200	2631 to 2983

Grade 8 Bolts, Nuts, and Studs		
		
Size	Pound-Inches	Newton metres
1/4 inch	144 to 180	16 to 20
5/16 inch	288 to 348	33 to 39
3/8 inch	540 to 648	61 to 73
Size	Pound-Feet	Newton metres
7/16 inch	70 to 84	95 to 114
1/2 inch	110 to 132	149 to 179
9/16 inch	160 to 192	217 to 260
5/8 inch	220 to 264	298 to 358
3/4 inch	380 to 456	515 to 618
7/8 inch	600 to 720	814 to 976
1.0 inch	900 to 1080	1220 to 1465
1-1/8 inch	1280 to 1440	1736 to 1953
1-1/4 inch	1820 to 2000	2468 to 2712
1-3/8 inch	2380 to 2720	3227 to 3688
1-1/2 inch	3160 to 3560	4285 to 4827

NOTE: Use thick nuts with Grade 8 bolts.

TORQUE SPECIFICATIONS - METRIC HARDWARE

Use the following torques when specifications are not given.

These values apply to fasteners with coarse threads as received from supplier, plated or unplated, or when lubricated with engine oil. These values do not apply if graphite or Molydisulfide grease or oil is used.

Grade 8.8 Bolts, Nuts, and Studs		
		
Size	Pound-Inches	Newton metres
M4	24 to 36	3 to 4
M5	60 to 72	7 to 8
M6	96 to 108	11 to 12
M8	228 to 276	26 to 31
M10	456 to 540	52 to 61
Size	Pound-Feet	Newton metres
M12	66 to 79	90 to 107
M14	106 to 127	144 to 172
M16	160 to 200	217 to 271
M20	320 to 380	434 to 515
M24	500 to 600	675 to 815
M30	920 to 1100	1250 to 1500
M36	1600 to 1950	2175 to 2600

Grade 10.9 Bolts, Nuts, and Studs		
		
Size	Pound-Inches	Newton metres
M4	36 to 48	4 to 5
M5	84 to 96	9 to 11
M6	132 to 156	15 to 18
M8	324 to 384	37 to 43
Size	Pound-Feet	Newton metres
M10	54 to 64	73 to 87
M12	93 to 112	125 to 150
M14	149 to 179	200 to 245
M16	230 to 280	310 to 380
M20	450 to 540	610 to 730
M24	780 to 940	1050 to 1275
M30	1470 to 1770	2000 to 2400
M36	2580 to 3090	3500 to 4200

Grade 12.9 Bolts, Nuts, and Studs

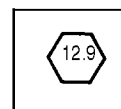

Usually the torque values specified for grade 10.9 fasteners can be used satisfactorily on grade 12.9 fasteners.

TORQUE SPECIFICATIONS - STEEL HYDRAULIC FITTINGS

Tube OD Hose ID	Thread Size	Pound- Inches	Newton metres
37 Degree Flare Fitting			
1/4 inch 6.4 mm	7/16-20	72 to 144	8 to 16
5/16 inch 7.9 mm	1/2-20	96 to 192	11 to 22
3/8 inch 9.5 mm	9/16-18	120 to 300	14 to 34
1/2 inch 12.7 mm	3/4-16	180 to 504	20 to 57
5/8 inch 15.9 mm	7/8-14	300 to 696	34 to 79
Tube OD Hose ID	Thread Size	Pound- Inches	Newton metres
3/4 inch 19.0 mm	1-1/16-12	40 to 80	54 to 108
7/8 inch 22.2 mm	1-3/16-12	60 to 100	81 to 135
1.0 inch 25.4 mm	1-5/16-12	75 to 117	102 to 158
1-1/4 inch 31.8 mm	1-5/8-12	125 to 165	169 to 223
1-1/2 inch 38.1 mm	1-7/8-12	210 to 250	285 to 338

Tube OD Hose ID	Thread Size	Pound- Inches	Newton metres
Straight Threads with O-ring			
1/4 inch 6.4 mm	7/16-20	144 to 228	16 to 26
5/16 inch 7.9 mm	1/2-20	192 to 300	22 to 34
3/8 inch 9.5 mm	9/16-18	300 to 480	34 to 54
1/2 inch 12.7 mm	3/4-16	540 to 804	57 to 91
Tube OD Hose ID	Thread Size	Pound- Inches	Newton metres
5/8 inch 15.9 mm	7/8-14	58 to 92	79 to 124
3/4 inch 19.0 mm	1-1/16-12	80 to 128	108 to 174
7/8 inch 22.2 mm	1-3/16-12	100 to 160	136 to 216
1.0 inch 25.4 mm	1-5/16-12	117 to 187	159 to 253
1-1/4 inch 31.8 mm	1-5/8-12	165 to 264	224 to 357
1-1/2 inch 38.1 mm	1-7/8-12	250 to 400	339 to 542

Split Flange Mounting Bolts		
Size	Pound- Inches	Newton metres
5/16-18	180 to 240	20 to 27
3/8-16	240 to 300	27 to 34
7/16-14	420 to 540	47 to 61
Size	Pound- Feet	Newton metres
1/2-13	55 to 65	74 to 88
5/8-11	140 to 150	190 to 203

TORQUE SPECIFICATIONS - STEEL HYDRAULIC FITTINGS

Nom. SAE Dash Size	Tube OD	Thread Size	Pound-Inches	Newton metres	Thread Size	Pound-Inches	Newton metres
O-ring Face Seal End					O-ring Boss End Fitting or Lock Nut		
-4	1/4 inch 6.4 mm	9/16-18	120 to 144	14 to 16	7/16-20	204 to 240	23 to 27
-6	3/8 inch 9.5 mm	11/16-16	216 to 240	24 to 27	9/16-18	300 to 360	34 to 41
-8	1/2 inch 12.7 mm	13/16-16	384 to 480	43 to 54	3/4-16	540 to 600	61 to 68
					Thread Size	Pound-Inches	Newton metres
-10	5/8 inch 15.9 mm	1-14	552 to 672	62 to 76	7/8-14	60 to 65	81 to 88
Nom. SAE Dash Size	Tube OD	Thread Size	Pound-Inches	Newton metres	1-1/16-12	85 to 90	115 to 122
					1-3/16-12	95 to 100	129 to 136
-12	3/4 inch 19.0 mm	1-3/16-12	65 to 80	90 to 110	1-5/16-12	115 to 125	156 to 169
-14	7/8 inch 22.2 mm	1-3/16-12	65 to 80	90 to 110	1-5/8-12	150 to 160	203 to 217
-16	1.0 inch 25.4 mm	1-7/16-12	92 to 105	125 to 140	1-7/8-12	190 to 200	258 to 271
-20	1-1/4 inch 31.8 mm	1-11/16-12	125 to 140	170 to 190			
-24	1-1/2 inch 38.1 mm	2-12	150 to 180	200 to 254			

Section 2002

RADIATOR AND ENGINE REMOVAL AND INSTALLATION

CASE CORPORATION
700 State Street
Racine, WI 53404 U.S.A.

CASE CANADA CORPORATION
3350 South Service Road
Hamilton, ON L7N 3M6 CANADA

Bur 7-17820

Copyright © 2000 Case Corporation
Printed in U.S.A.
June, 2000

RADIATOR

Removal

STEP 1

Park the machine on a level surface. Lower the blade to the floor and stop the engine.

STEP 2



BD00F263

Disconnect the negative battery cable.

STEP 3

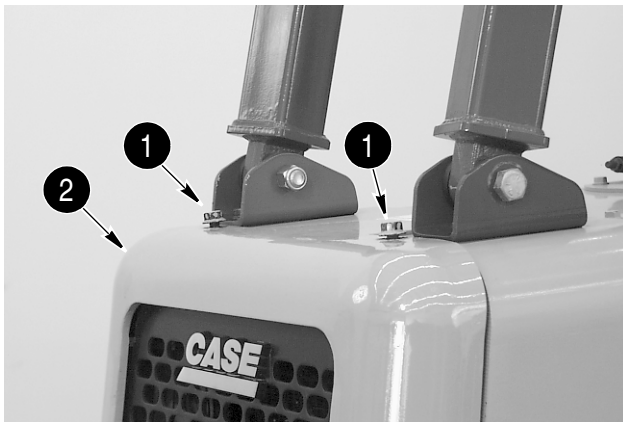

BD00F214

Remove the two bolts (1) securing the grille (2).

STEP 4



BD00F215

Lower the grille. Install lifting eyes in the two holes in the grille from which the bolts were removed. Connect suitable lifting equipment to the lifting eyes.

STEP 5



BD00F216

Remove the grille stop bolts to gain access to the grille hinge bolts.

STEP 6

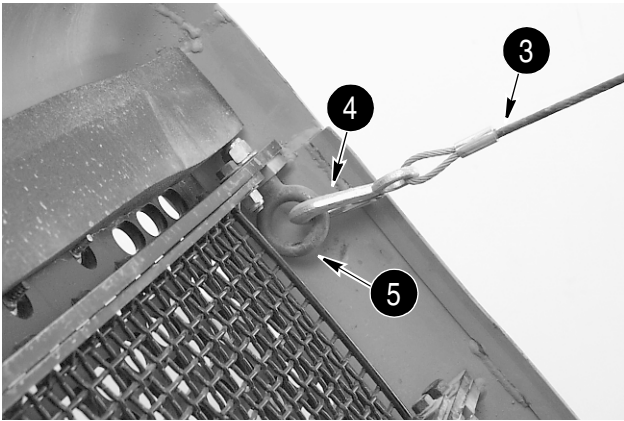

BD00E070

Lower the grille leaving slack in the cable (3). Disconnect the hook (4) from the eyebolt (5).

STEP 7



BD00F218

Lower the grille to gain access to the three bolts securing the grille hinge to the machine.

STEP 8

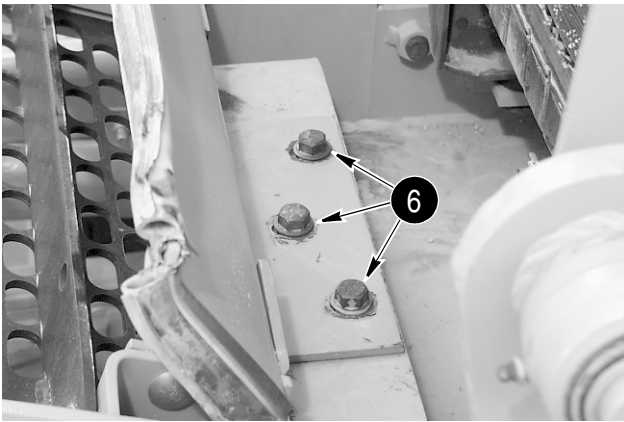

BD00F219

Loosen and remove the three bolts (6).

STEP 9



BD00F221

Remove the grille from the machine. Then remove the engine side covers.

STEP 10

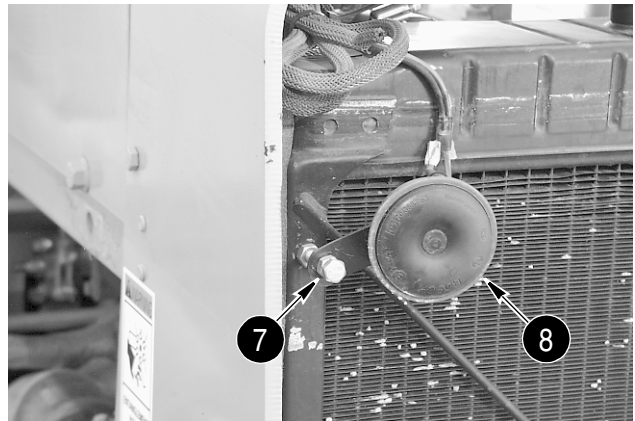

BD00F224

Remove the bolt (7) and two nuts securing the horn (8) to the radiator.

STEP 11

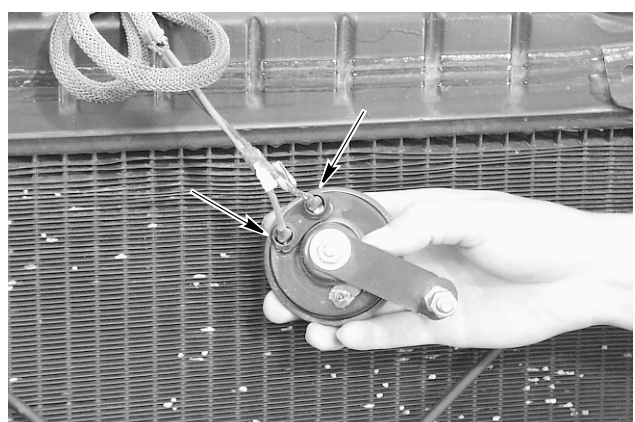

BD00F226

Disconnect the two wires from the horn.

STEP 12

BD00F296

Make sure the engine is cool and remove the radiator cap. Disconnect and plug the coolant recovery hose (10).

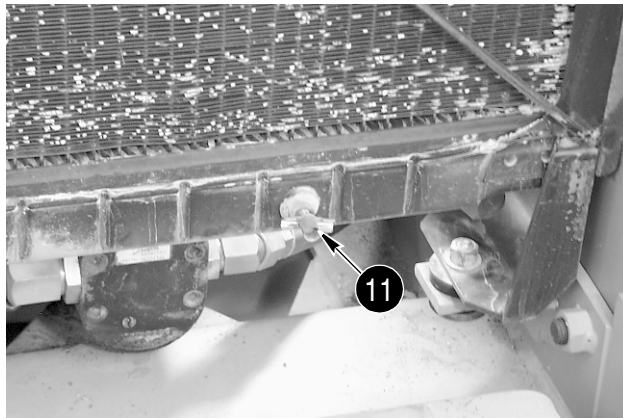
STEP 13

BD00F225

Connect a hose to the drain valve (11). Place the other end of the hose in a clean six gallon container. Open the drain valve and drain the coolant. After the radiator is drained install the radiator cap (9) to prevent debris from falling inside the radiator.

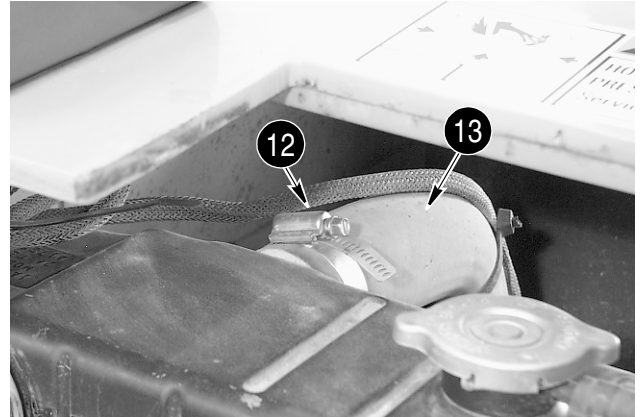
STEP 14

BD00F222

Pull the wiring harness for the horn back behind the radiator. Loosen the clamp (12) and disconnect the radiator hose (13).

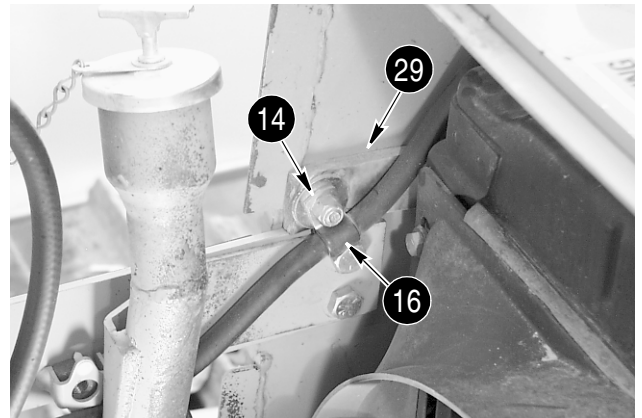
STEP 15

BD00F258

Remove the lock nut (14), washers (15), clamp (16), and bolts (17) securing the mounting straps (29) to the machine.

STEP 16

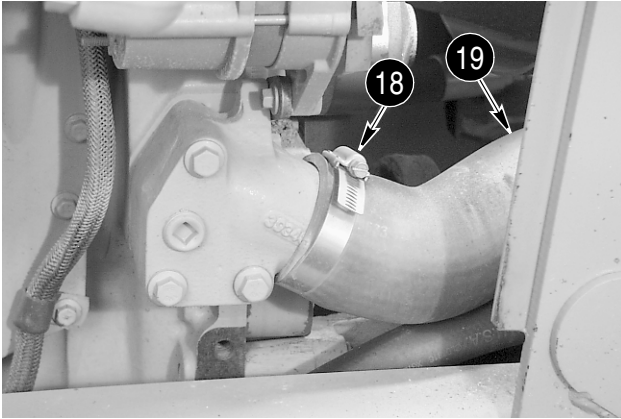

BD00F232

Loosen the clamp (18) and disconnect the hose (19).

STEP 17

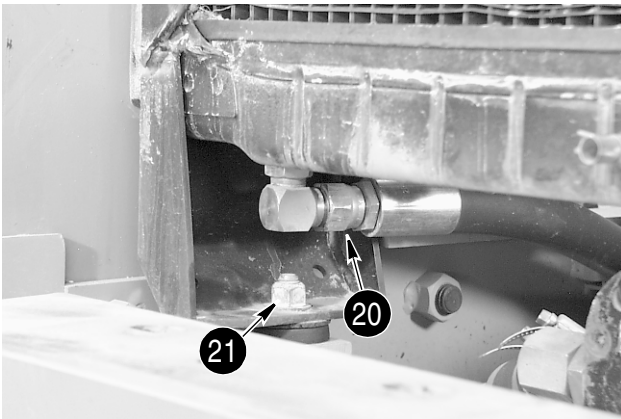

BD00F230

Connect suitable lifting equipment to the radiator. Place a container beneath the machine to catch hydraulic oil that will drain when the tube (20) is disconnected from the radiator bottom port. Disconnect the hose, then plug the hose and cap the radiator port. Repeat for the other side. Then while an assistant holds the bolt (23) accessible through a hole in the bottom of the frame, remove the lock nut (21) and washer (22). Remove bolt (23) and washers (24). Repeat for the other side of the radiator.

STEP 18

Carefully move the radiator forward until the fan shroud is clear of the fan. Pull the radiator forward until clear of the radiator cover then remove radiator from machine.

STEP 19

Remove washer (25). Remove radiator mounts (26) only if replacement is necessary.

STEP 20

If radiator is being replaced, remove bolts (27), washers (28), and two mounting straps (29).

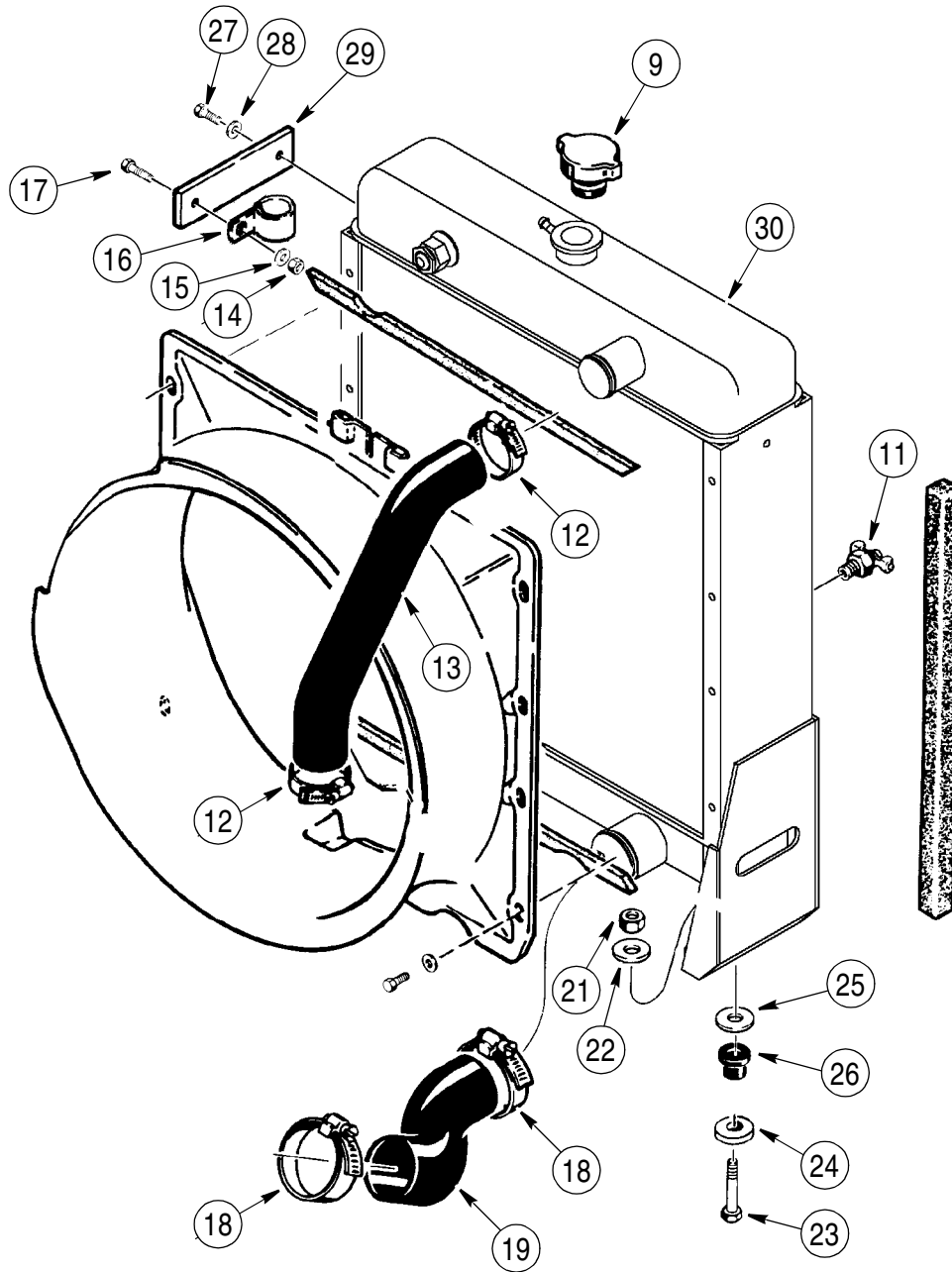

- | | | | |
|-----------------|--------------------|--------------|--------------|
| 11. DRAIN VALVE | 16. CLAMP | 21. LOCK NUT | 28. WASHER |
| 12. CLAMP | 29. MOUNTING STRAP | 22. WASHER | 24. WASHER |
| 17. BOLT | 18. CLAMP | 25. WASHER | 13. HOSE |
| 14. LOCK NUT | 19. HOSE | 26. MOUNT | 9. CAP |
| 15. WASHER | 23. BOLT | 27. BOLT | 30. RADIATOR |

BS00E102

Installation

STEP 21

If mounting straps (29) were removed from the radiator, install using bolt (27) and washer (28). Tighten the bolt to a torque of 13 to 16 Nm (115.1 to 141.6 lb-inch). Repeat to install mounting strap on opposite side of radiator. Tighten bolts to a torque of 13 to 16 Nm (115 to 142 lb-inch).

STEP 22

If radiator mounts (26) were removed for replacement, apply a light coat of water from bottom of shank to 3 mm (1/8 inch) up from bottom. Insert mount in welded bracket by rotating and pushing mount until partially positioned. Install bolt making sure that bolt head does not overhang the outside diameter of the mount metal insert; if it does, use a smaller bolt. Push the mount into the bracket with enough force to ensure there is no gap between bottom surface of mount head and surface of bracket.

STEP 23

Move the radiator into position in front of the machine and push the radiator into position on the mounts. Be careful not to damage the engine fan by hitting it with the fan shroud.

STEP 24

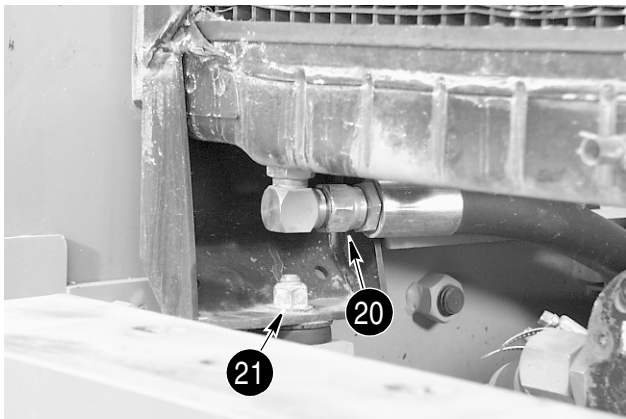

BD00F230

Raise one end of the radiator slightly and install the washer (25) on mount (26). Do the same on the other mount. Put washer (24) on bolt (23) and install bolt from bottom. Hold bolt while assistant installs washer (22) and lock nut (21). Install washers (24 and 22), bolt (23) and lock nut (21) on other side of radiator. Tighten bolts (23) to a torque of 68 to 82 Nm (50 to 60 lb-ft). Remove plug from hose (19) and cap from radiator port. Connect hose (20), repeat for the other side.

STEP 25

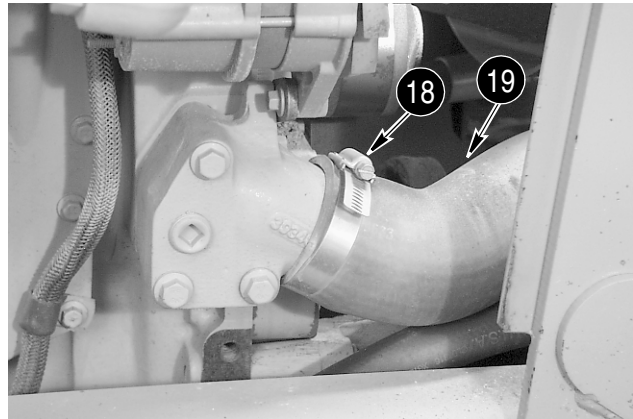

BD00F232

Install hose (19). Position clamps (18) and tighten to a torque of 9.6 to 13 Nm (85 to 115 lb-inch).

STEP 26

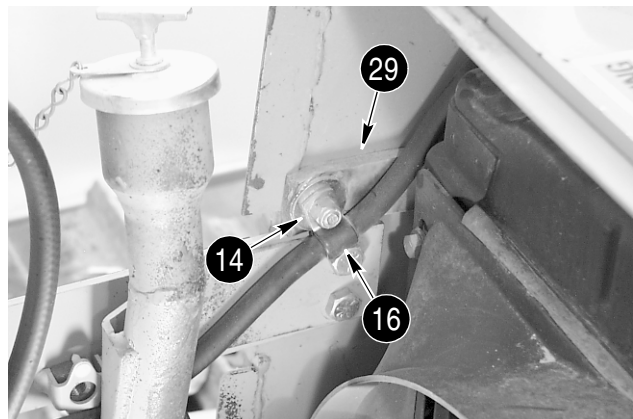

BD00F258

Put clamp (16) on coolant recovery hose. Install bolts (17), clamp (16), washers (15), and lock nut (14) to secure mounting straps (29). Tighten bolts to a torque of 13 to 16 Nm (115 to 142 lb-inch).

STEP 27

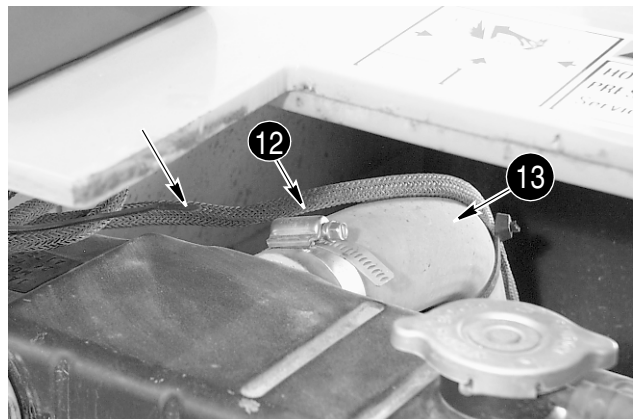

BD00F222

Install radiator hose (13) and tighten hose clamps (12) to a torque of 9.6 to 13 Nm (85 to 115 lb-inch). Pull horn wiring harness to front of radiator.

STEP 28



Connect the two wires to the horn.

STEP 29

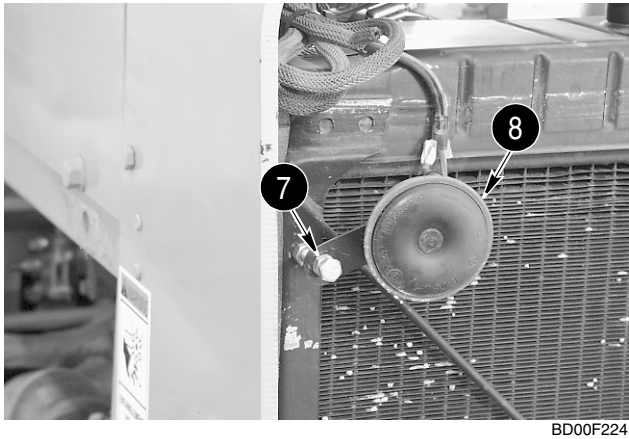

Install the bolt (7) and two nuts to secure the horn (8) to the radiator. Tighten the bottom nut against the radiator and the top nut against the horn mounting bracket.

STEP 30

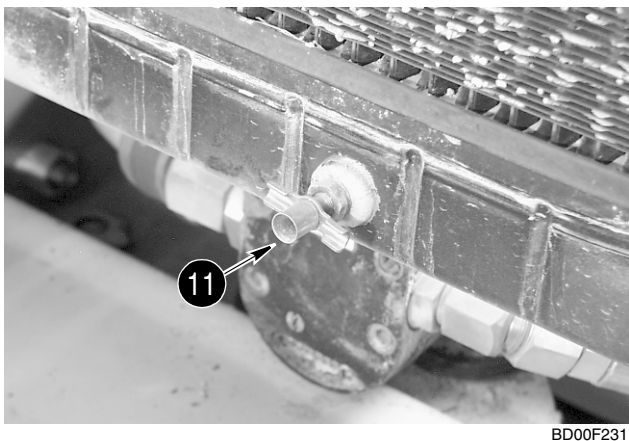

Close the drain valve (11).

STEP 31



Move the grille into position in front of the machine.

STEP 32

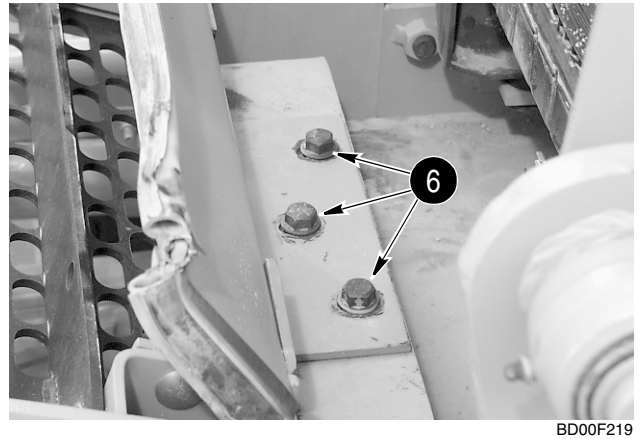

Install the three bolts (6).

STEP 33



BD00F215



BD00F216

Raise the grille so that the grille stop bolts can be installed.

STEP 34

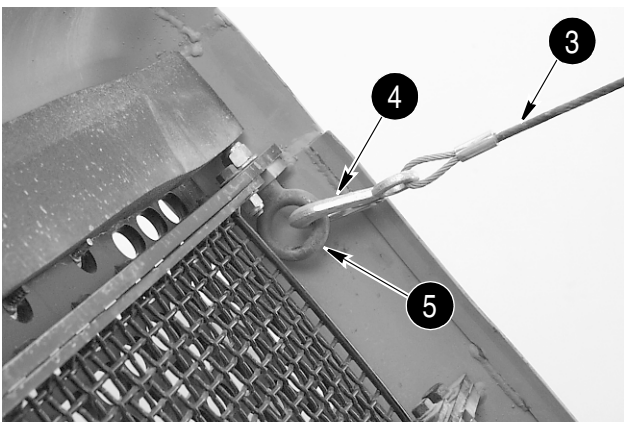

BD00E070

Lower the grille enough to connect the cable (3) and hook (4) to the eyebolt (5). Disconnect the lifting equipment and remove the lifting eyes from the grille.

STEP 35

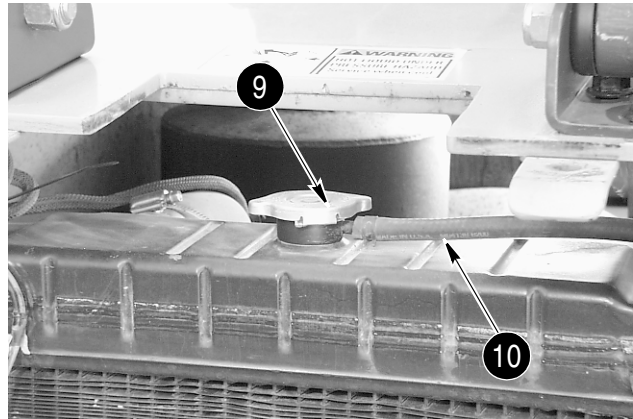

BD00F223

Connect the coolant recovery hose (9). Fill the radiator with a mixture of 50% ethylene glycol and 50% water. Install the radiator cap (29). Fill the coolant reservoir up to the FULL mark on the reservoir.

STEP 36

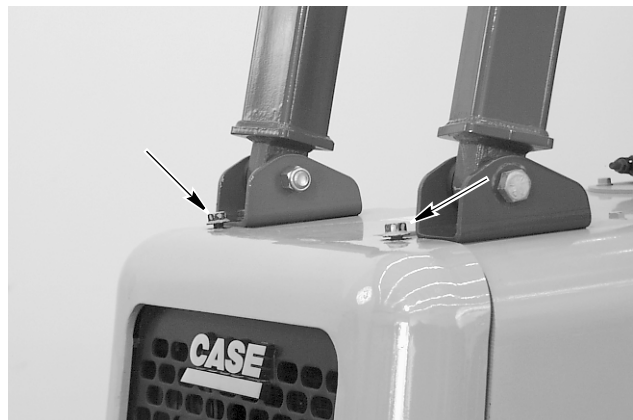

BD00F214

Raise grille into position and install the two bolts.

STEP 37

Reconnect the negative battery cable to the battery.

STEP 38

Start the engine and run the engine at low idle. Check for leaks. When the coolant is at operating temperature, stop the engine. When engine has cooled, check the coolant level at the reservoir.

STEP 39

Install the engine side panels.

ENGINE

Removal

NOTE: *Since the engine is the only support for the torque converter, the torque converter must be removed with the engine.*

STEP 40

Remove the radiator (Steps 1 through 20).

STEP 41



BD00F234

If machine is equipped with a brush guard, connect suitable lifting equipment to brush guard. Remove four bolts, lock nuts, and washers securing brush guard. Remove brush guard.

STEP 42

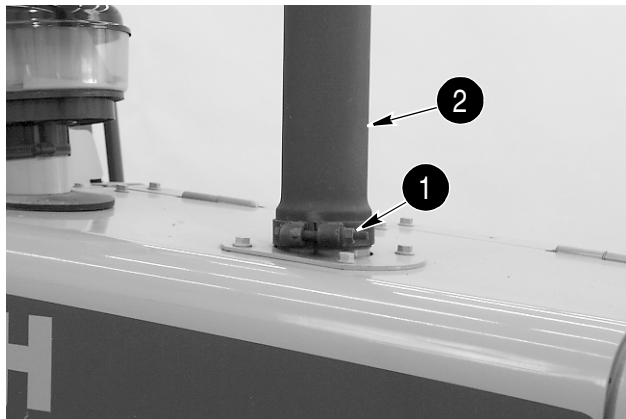

BD00F235

Loosen the clamp (1) on the exhaust pipe (2). Remove the exhaust pipe.

STEP 43

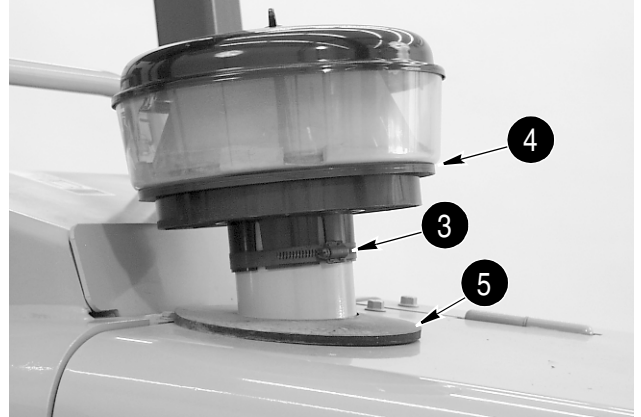

BD00F236

Loosen the clamp (3) on the precleaner assembly (4). Remove the precleaner assembly and rubber pad (5).

STEP 44



BD00F220

Remove the engine side covers from both sides.

STEP 45

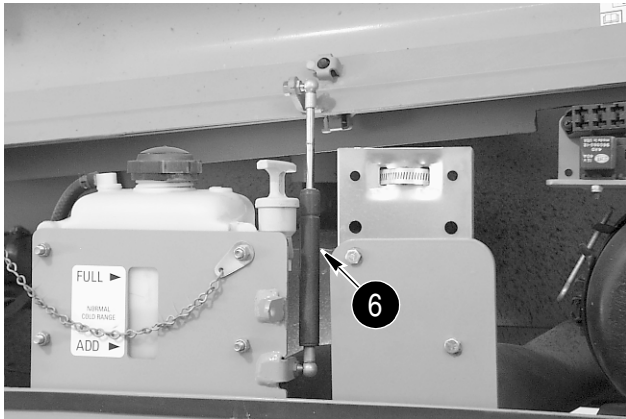

BD00F238

Open the LH engine hood. Remove the lock nut securing the bottom of the spring (6). Support the hood and disconnect the bottom of the spring from the bracket. Close but do not latch the hood.

STEP 46

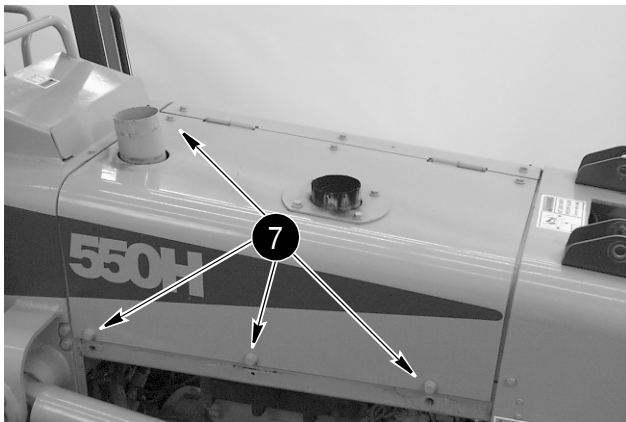

BD00F237

Remove four bolts (7) securing the engine hood.

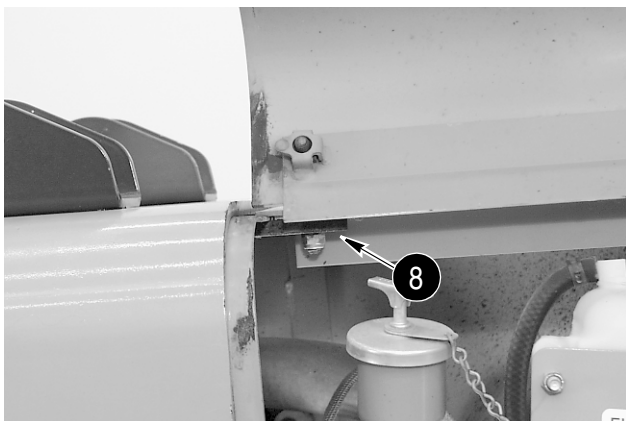

BD00F239

At the front of the engine hood, remove bolt, lock nut, washer, and plate (8). Remove the RH and LH engine hoods and hinge as an assembly.

STEP 47

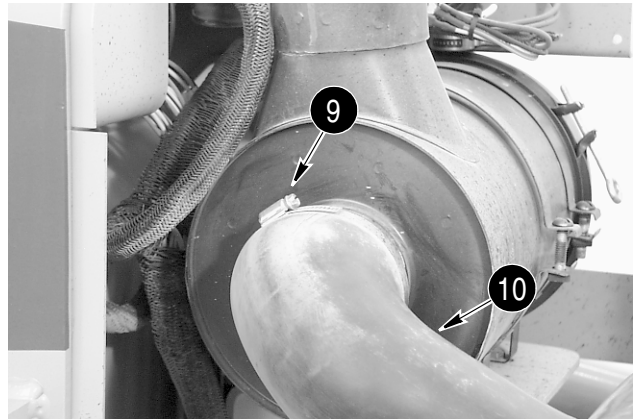

BD00F250

Loosen the clamp (9) and disconnect the hose (10) from the air cleaner assembly.

STEP 48

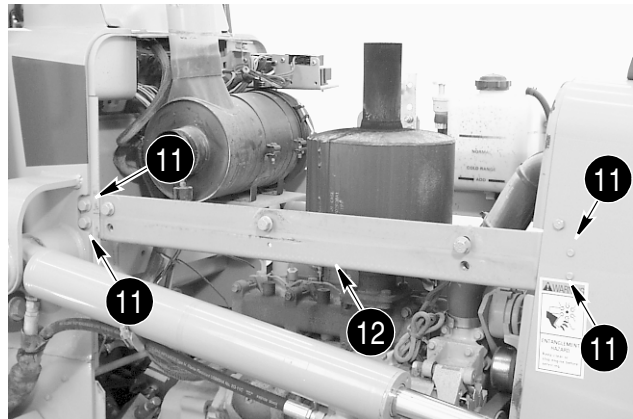

BD00F251

Remove the four bolts (11) from the RH support bracket (12). Remove the RH support bracket.

STEP 49

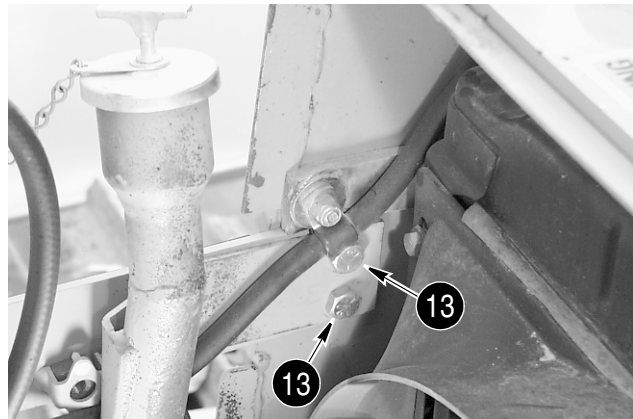

BD00F258

Remove the two bolts (13) from the LH support panel.

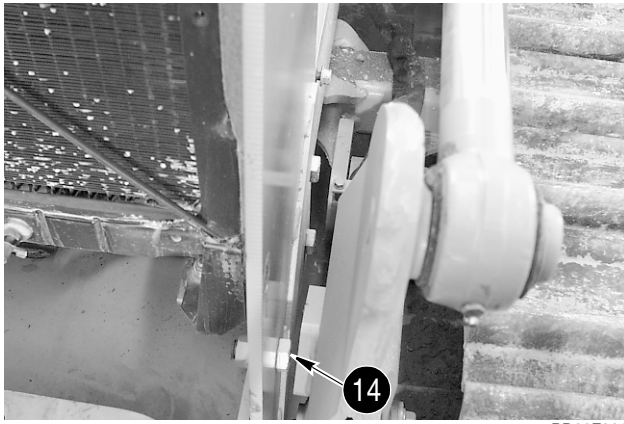

BD00F261

Remove the bolts (14) from both sides of the radiator guard.



BD00F260

Connect suitable lifting equipment to the radiator guard and remove.

STEP 50

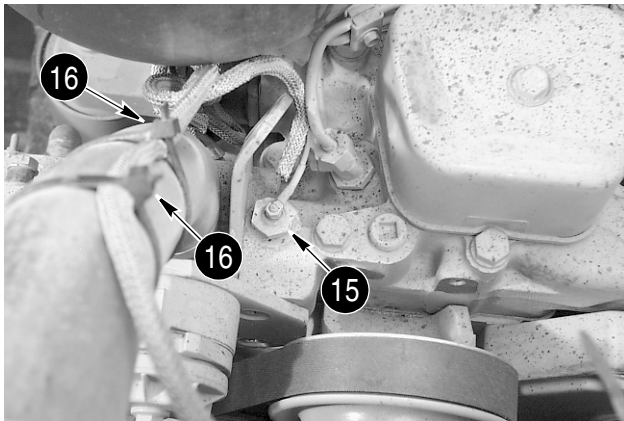

BD00F257

Tag and disconnect the wiring harness wire from the coolant temperature sender (15). Cut, remove, and discard the two tie straps (16) holding the wiring harness to the radiator hose.

STEP 51

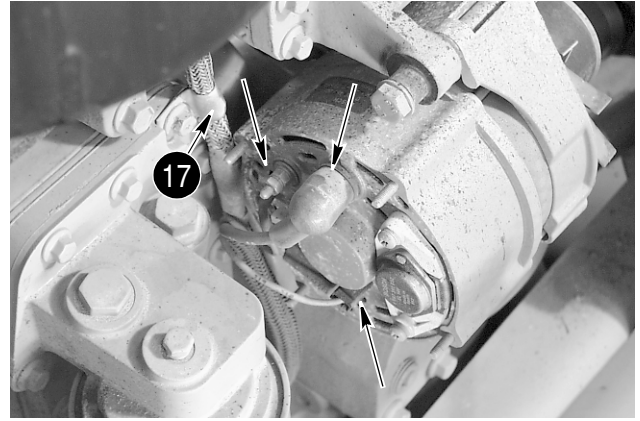

BD00F256

Tag and disconnect the wires from the alternator. Remove the bolt securing the clamp (17). Remove the clamp.

STEP 52

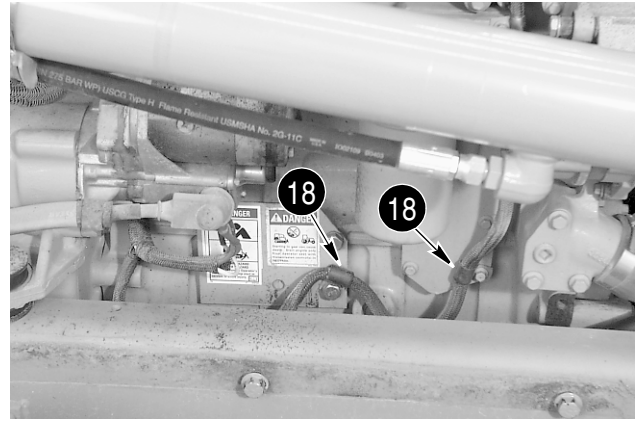

BD00F253

Remove the bolts securing the two clamps (18). Remove the clamps.

STEP 53

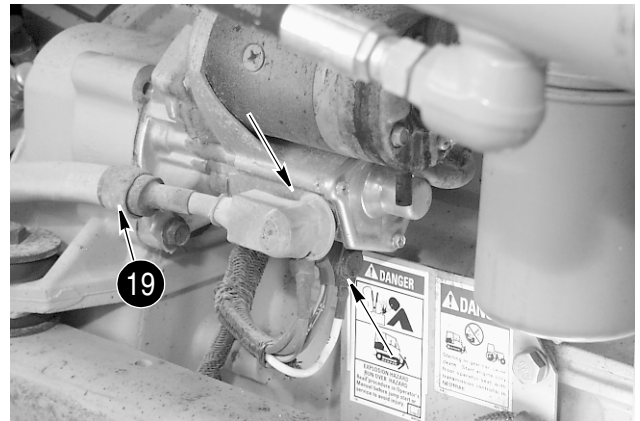

BD00F254

Tag and disconnect the battery cable and the four wiring harness wires from the starter. Remove the bolt securing the clamp (19) and the battery cable to the starter. Move the battery cable out of the way.

STEP 54

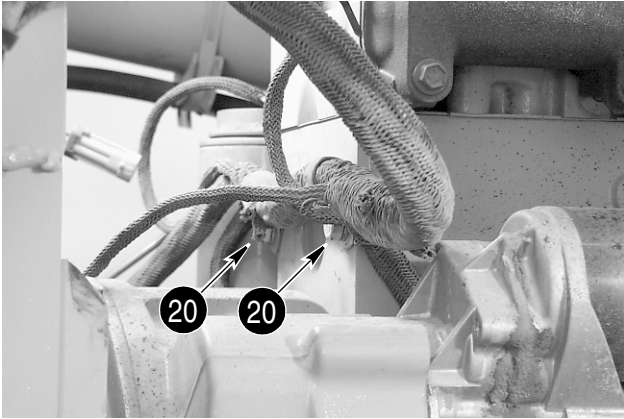

BD00F255

Remove the bolts securing the two clamps (20). Remove the clamps. Pull the wiring harness branch on the RH side of the engine up between the starter and the engine block and move out of the way.

STEP 55

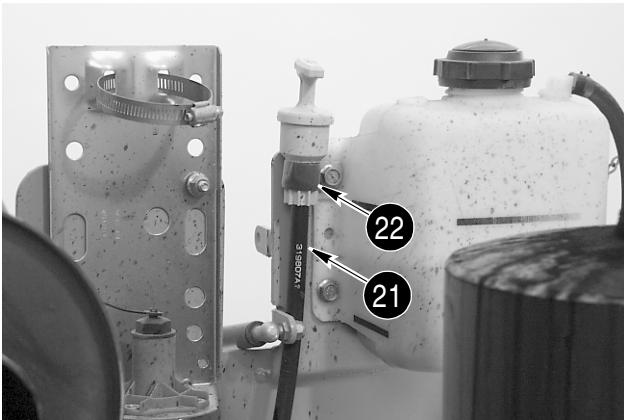

BD00F259

Remove the bolt securing the oil dip stick tube (21) clamp (22).

STEP 56

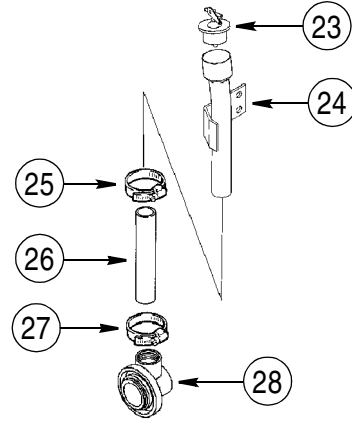

BS00E123

Loosen clamp (27) at bottom of oil fill tube (24) hose (26). Pull hose and oil fill tube from connector (28) installed in engine front cover. Plug connector to prevent entry of foreign matter.

STEP 57

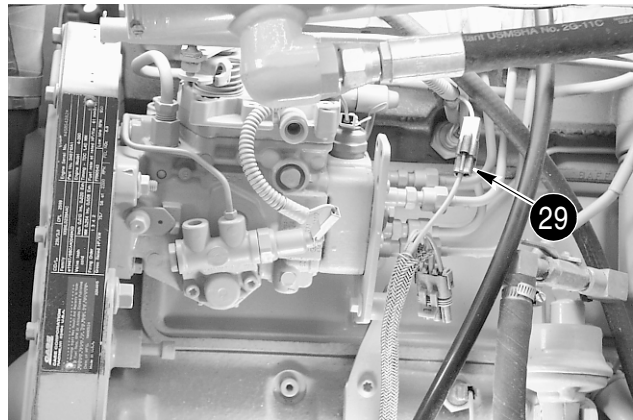

BD00F245

Disconnect fuel injection pump connector (29) from wiring harness connector.

STEP 58

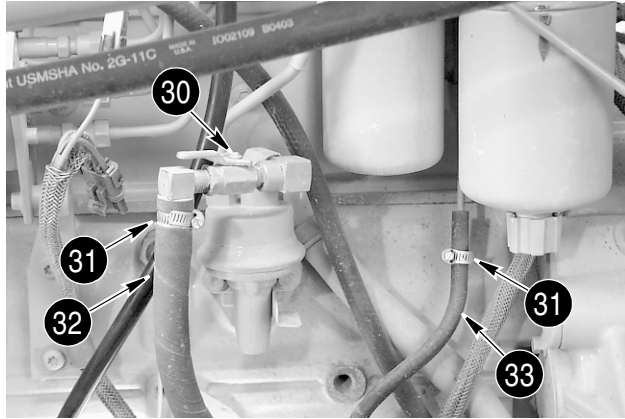

BD00F247

Turn the fuel supply valve (30) off and loosen the clamps (31) on the fuel supply (32) and fuel return (33) lines. Disconnect the hoses. Plug the hoses and cap the fittings.

STEP 59

Drain the hydraulic reservoir.

STEP 60



BD00F229

Clean the equipment pump hose connections to remove all dirt and grease. Disconnect the pressure hose (34) and the suction hose (35). Install a plug in the pressure hose and the suction hose. Tighten the clamp on the suction hose to secure the installed plug. Cap the fittings installed in the pump ports.

STEP 61

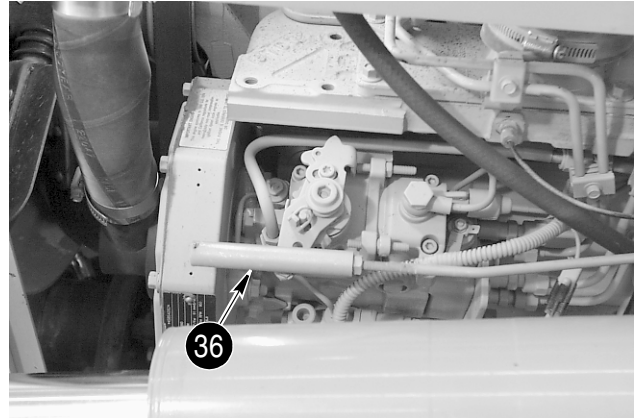

BD00F241

Disconnect the control rod (36) from the fuel injection pump lever.

STEP 62

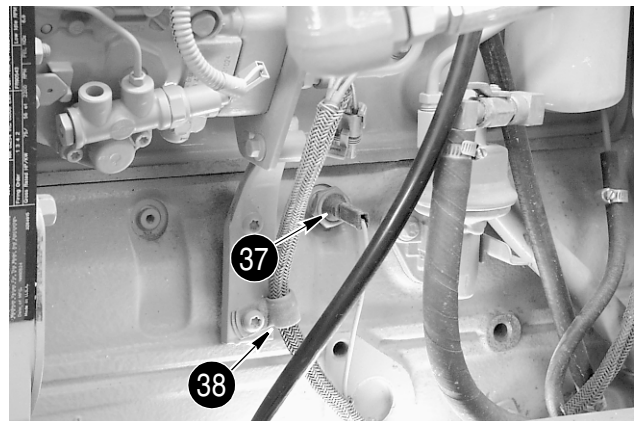

BD00F246

Tag and disconnect the wire from the engine oil pressure switch (37). Remove the screw securing the clamp (38).

STEP 63

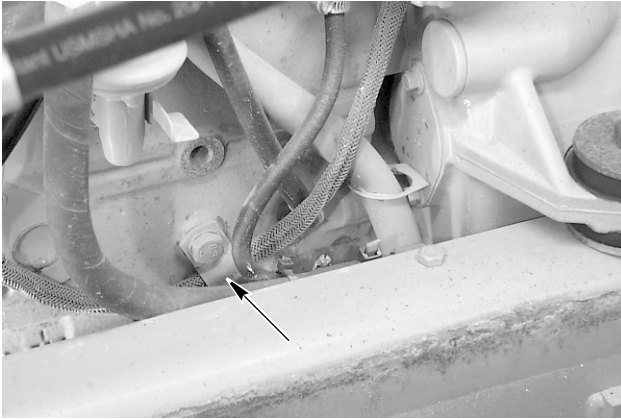

BD00F248

Remove the bolt securing the clamp. Carefully pull the wiring harness towards the rear of the engine compartment and away from the engine.

STEP 64

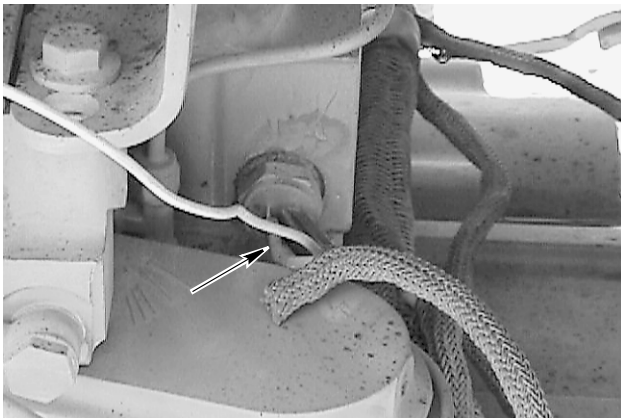

BD00F299

Disconnect the wiring harness wire from the ether injection temperature switch.

STEP 65



BD00F242

Disconnect the ether injection tube (39) from the nozzle in the intake manifold.

STEP 66

Remove the undercarriage guards below the torque converter and engine.

STEP 67

Remove the bolt that secures the negative battery cable to the torque converter housing.

STEP 68

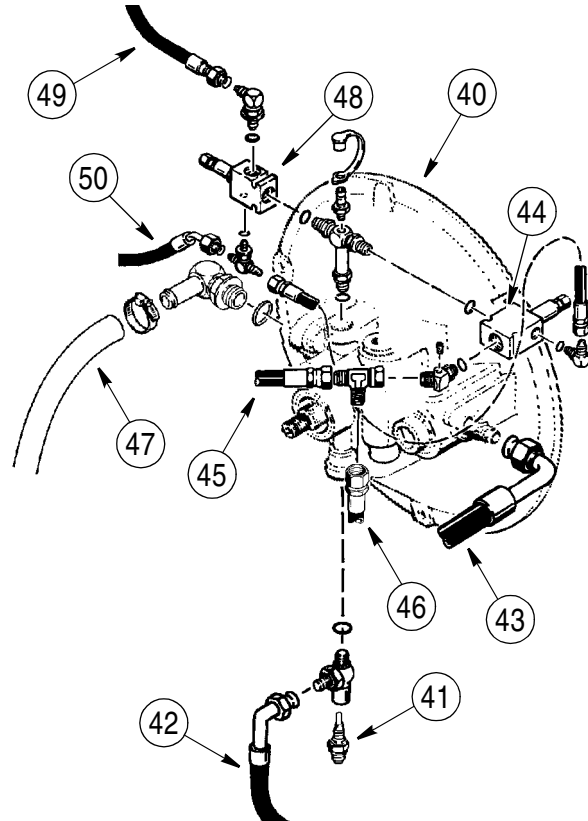

BS00E124

At the torque converter (40), tag and disconnect the wiring harness wire from the transmission temperature sender (41).

STEP 69

Tag and disconnect oil cooler hose (42). Install a plug in the hose and cap the fitting.

STEP 70

Tag and disconnect the oil filter hose (43). Install a plug in the hose and cap the fitting.

STEP 71

At the tee installed in the relief valve (44), tag and disconnect the transmission control valve hose (45) and the brake valve hose (46). Install a plug in the hoses and cap the fittings.

STEP 72

At the suction filter hose (47), loosen the clamp and disconnect the hose. Plug the hose and cap the fitting.

STEP 73

At the inlet relief valve (48), tag and disconnect the lube circuit hose (49) and the drain hose (50) connected to the transmission. Plug the hoses and cap the fittings.

STEP 74

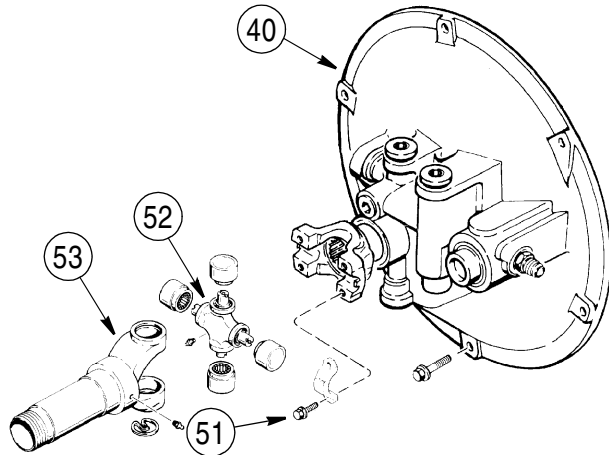

B911231J

Remove the bolts (51) that secure the universal joint (52) to the output shaft of the torque converter (40). Use a piece of wire to hold the drive shaft (53) out of the way.

STEP 75

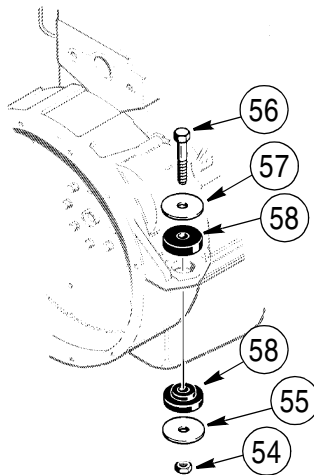

BS00E121

Remove nut (54), washer (55), bolt (56), and washer (57) from mounting flange on each side of the flywheel housing.

STEP 76

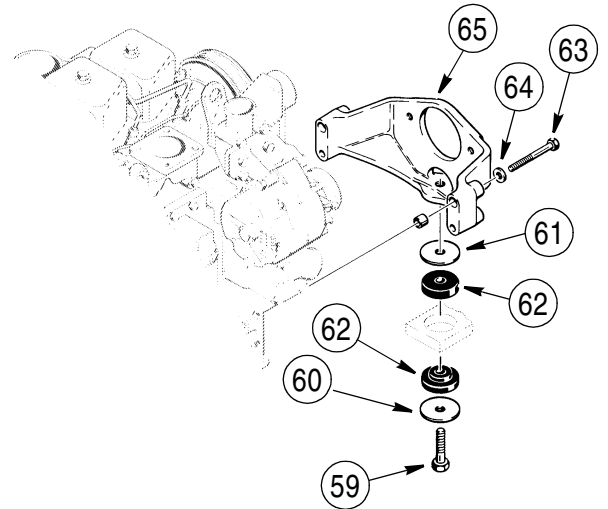

BS00E122

Remove bolt (59), and washer (60) from engine front support (65).

STEP 77

Connect suitable lifting equipment to lifting eyes on the engine. Raise engine and remove from machine.

STEP 78

Remove washer (61) and engine mounts (58 and 62) from mounting flange on each side of flywheel housing and machine frame.

STEP 79

If engine front support (65) requires removal, connect suitable lifting equipment to front support. Remove four bolts (63) and washers (64). Remove front support from engine.

STEP 80

Refer to Section 6006 to remove the torque converter from the engine.

Installation**STEP 81**

Refer to Section 6006 to install the torque converter on the engine.

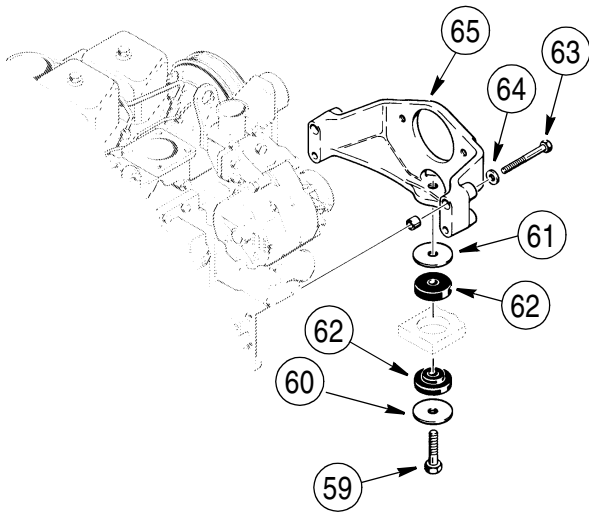
STEP 82

NEUNUMBER

If engine front support (65) was removed, connect suitable lifting equipment to front support and move into position at front of engine. Install four bolts (63) and washers (64). Tighten bolts to a torque of 125 to 156 Nm (92 to 115 lb-ft).

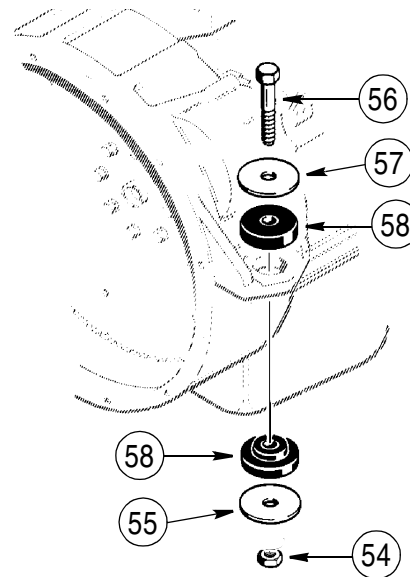
STEP 83

NEUNUMBER

Install engine mounts (58 and 62) in mounting flange on each side of flywheel housing and machine frame. Place washer (61) on engine mount (62).

STEP 84

Connect suitable lifting equipment to lifting eyes on the engine. Raise engine and move into position on machine. Carefully lower engine into machine.

STEP 85

Install washer (60) and bolt (59).

STEP 86

Install washer (57), bolt (56), washer (58), and nut (54) in mounting flange on each side of the flywheel housing.

STEP 87

Tighten bolt (59) to a torque of 203 to 230 Nm (150 to 170 lb-ft), then tighten bolts (56) to same torque. Disconnect lifting equipment from engine lifting eyes.



Suggest:

If the above button click is invalid.

Please download this document

first, and then click the above link

to download the complete manual.

Thank you so much for reading

STEP 88

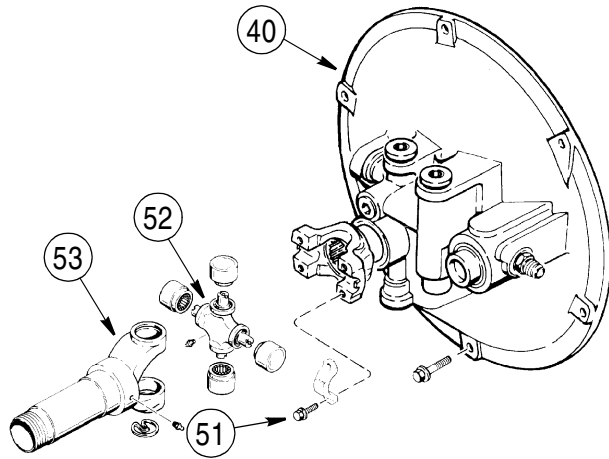

B911231J

Remove wire holding drive shaft (53) out of the way. Position universal joint (54) on output shaft of torque converter (42) and install bolts (51). Tighten bolts to a torque of 18 to 24 Nm (159.3 to 216 lb-inch).

STEP 89

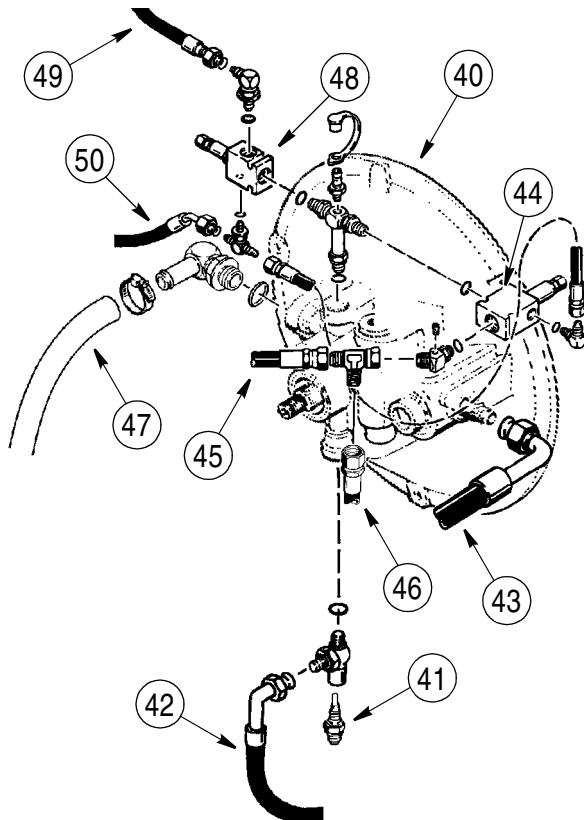

BS00E124

Remove plugs from hoses and caps from fittings. Connect drain hose (50) and lube circuit hose (49) to inlet relief valve (48).

STEP 90

Remove plug from hose and cap from fitting. Connect suction filter hose (47) and tighten hose clamp.

STEP 91

Remove plugs from hoses and caps from fittings. Connect the brake valve hose (46) and transmission control valve hose (45) to the tee installed in the relief valve (44).

STEP 92

Remove plug from hose and cap from fitting. Connect the oil filter hose (43).

STEP 93

Remove the plug from the hose and cap from fitting. Connect the oil cooler hose (42).

STEP 94

Connect the wiring harness wire to the transmission temperature sender (41).

STEP 95

Install the bolt to secure the negative battery cable to the torque converter housing.

STEP 96



BD00F242

Connect the ether injection tube to the nozzle in the intake manifold.

<https://www.ebooklibonline.com>

Hello dear friend!

Thank you very much for reading.

Enter the link into your browser.

The full manual is available for immediate download.

<https://www.ebooklibonline.com>