

521G
Tier 2
Wheel Loader

SERVICE MANUAL

Part number 48083739

English

July 2018

© 2018 CNH Industrial Italia S.p.A. All Rights Reserved.

CASE
CONSTRUCTION



SERVICE MANUAL

521G XT - EH, NEW CAB TIER2 [FNH0521GNGHE00001 -]
521G ZBAR - EH, NEW CAB TIER2 [FNH0521GNGHE00001 -]

Contents

INTRODUCTION

Engine.....	10
[10.001] Engine and crankcase	10.1
[10.216] Fuel tanks	10.2
[10.202] Air cleaners and lines	10.3
[10.254] Intake and exhaust manifolds and muffler	10.4
[10.400] Engine cooling system	10.5
[10.414] Fan and drive	10.6
[10.310] Aftercooler.....	10.7
[10.304] Engine lubrication system.....	10.8
Transmission.....	21
[21.113] Powershift transmission	21.1
[21.135] Powershift transmission external controls.....	21.2
[21.155] Powershift transmission internal components.....	21.3
Four-Wheel Drive (4WD) system	23
[23.314] Drive shaft.....	23.1
Front axle system	25
[25.100] Powered front axle	25.1
[25.102] Front bevel gear set and differential	25.2
[25.108] Final drive hub, steering knuckles, and shafts	25.3
[25.310] Final drives	25.4
Rear axle system.....	27
[27.100] Powered rear axle.....	27.1
[27.106] Rear bevel gear set and differential.....	27.2
[27.120] Planetary and final drives	27.3
[27.124] Final drive hub, steering knuckles, and shafts	27.4

<https://www.ebooklibonline.com>

Hello dear friend!

Thank you very much for reading.

Enter the link into your browser.

The full manual is available for immediate download.

<https://www.ebooklibonline.com>

Brakes and controls	33
[33.202] Hydraulic service brakes	33.1
[33.110] Parking brake or parking lock	33.2
Hydraulic systems.....	35
[35.000] Hydraulic systems.....	35.1
[35.300] Reservoir, cooler, and filters.....	35.2
[35.106] Variable displacement pump	35.3
[35.359] Main control valve.....	35.4
[35.357] Pilot system	35.5
[35.204] Remote control valves	35.6
[35.752] Hydraulic fan drive cooling system.....	35.7
[35.701] Front loader arm hydraulic system	35.8
[35.723] Front loader bucket hydraulic system	35.9
[35.734] Tool quick coupler hydraulic system	35.10
Frames and ballasting	39
[39.100] Frame	39.1
Steering.....	41
[41.200] Hydraulic control components.....	41.1
[41.216] Cylinders	41.2
[41.910] Auxiliary steering	41.3
Wheels	44
[44.511] Front wheels.....	44.1
[44.520] Rear wheels	44.2
Cab climate control	50
[50.100] Heating	50.1
[50.200] Air conditioning.....	50.2
Electrical systems	55
[55.000] Electrical system	55.1

[55.100] Harnesses and connectors.....	55.2
[55.201] Engine starting system.....	55.3
[55.301] Alternator.....	55.4
[55.302] Battery.....	55.5
[55.512] Cab controls.....	55.6
[55.050] Heating, Ventilation, and Air-Conditioning (HVAC) control system.....	55.7
[55.415] Loader arm and bucket control system.....	55.8
[55.530] Camera.....	55.9
[55.DTC] FAULT CODES.....	55.10
Front loader and bucket.....	82
[82.100] Arm.....	82.1
[82.300] Bucket.....	82.2
Platform, cab, bodywork, and decals.....	90
[90.150] Cab.....	90.1
[90.120] Mechanically-adjusted operator seat.....	90.2
[90.124] Pneumatically-adjusted operator seat.....	90.3
[90.105] Machine shields and guards.....	90.4



INTRODUCTION

Safety rules

Personal safety





This is the safety alert symbol. It is used to alert you to potential personal injury hazards. Obey all safety messages that follow this symbol to avoid possible death or injury.

Throughout this manual you will find the signal words DANGER, WARNING, and CAUTION followed by special instructions. These precautions are intended for the personal safety of you and those working with you.

Read and understand all the safety messages in this manual before you operate or service the machine.

 DANGER indicates a hazardous situation that, if not avoided, will result in death or serious injury.

 WARNING indicates a hazardous situation that, if not avoided, could result in death or serious injury.

 CAUTION indicates a hazardous situation that, if not avoided, could result in minor or moderate injury.

FAILURE TO FOLLOW DANGER, WARNING, AND CAUTION MESSAGES COULD RESULT IN DEATH OR SERIOUS INJURY.

Machine safety

NOTICE: Notice indicates a situation that, if not avoided, could result in machine or property damage.

Throughout this manual you will find the signal word Notice followed by special instructions to prevent machine or property damage. The word Notice is used to address practices not related to personal safety.

Information

NOTE: Note indicates additional information that clarifies steps, procedures, or other information in this manual.

Throughout this manual you will find the word Note followed by additional information about a step, procedure, or other information in the manual. The word Note is not intended to address personal safety or property damage.

Personal safety

Carefully read this Manual before proceeding with maintenance, repairs, refuelling or other machine operations.

Repairs have to be carried out only by authorized and instructed staff; specific precautions have to be taken when grinding, welding or when using mallets or heavy hammers.

Non-authorized persons are not allowed to repair or carry out maintenance on this machine. Do not carry out any work on the equipment without prior authorization.

Ask your employer about the safety instructions in force and safety equipment.

Nobody should be allowed in the cab during machine maintenance unless he is a qualified operator helping with the maintenance work.

If it is necessary to move the equipment to carry out repairs or maintenance, do not lift or lower the equipment from any other position than the operator's seat.

Never carry out any operation on the machine when the engine is running, except when specifically indicated.

Stop the engine and ensure that all pressure is relieved from hydraulic circuits before removing caps, covers, valves, etc.

All repair and maintenance operations should be carried out with the greatest care and attention.

Service stairs and platforms used in a workshop or in the field should be built in compliance with the safety rules in force.

Any functional disorders, especially those affecting the safety of the machine, should therefore be rectified immediately.

⚠ DANGER

Unexpected movement!

Make sure parking brake is applied. Secure machine with wheel chocks.

Failure to comply will result in death or serious injury.

D0013A

Before performing any work on the machine, attach a maintenance in progress tag. This tag can be applied on the left-hand control lever, safety lever or cab door.

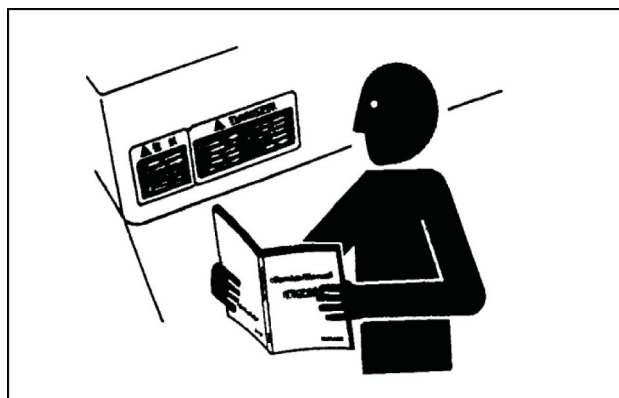

TULI12WEX2004AA 1

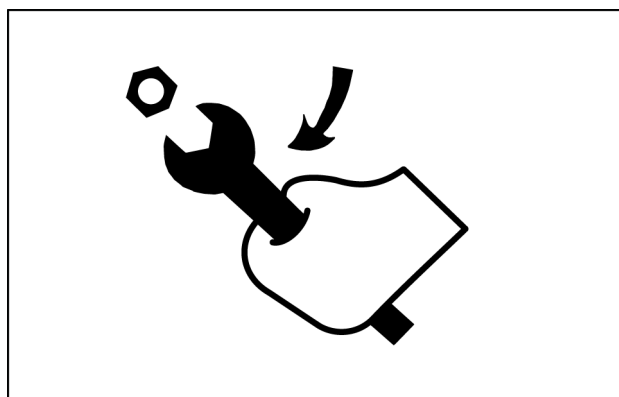

TULI12WEX2005AA 2

Emergency

Be prepared for emergencies. Always keep a fire extinguisher and first aid kit readily available. Ensure that the fire extinguisher is serviced in accordance with the manufacturer's instructions.

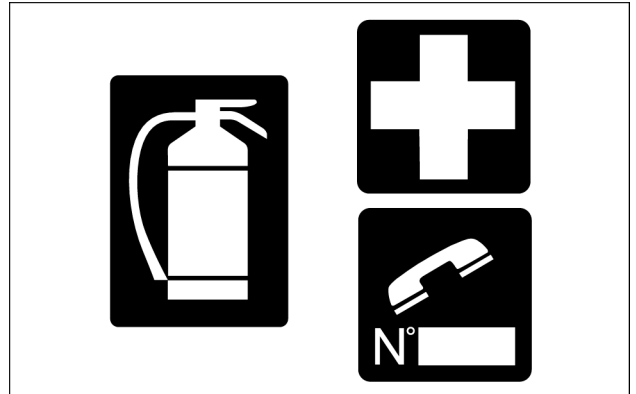

SMIL12WEX0174AA 3

Equipment

Wear close fitting clothing and safety equipment appropriate for the job:

- Safety helmet
- Safety shoes
- Heavy gloves
- Reflective clothing
- Wet weather clothing

If working conditions require, the following personal safety equipment should be on hand:

- Respirators (or dust proof masks)
- Ear plugs or acoustic ears protections
- Goggles with lateral shield or masks for eye protection

Do not wear rings, wristwatches, jewelry, unbuttoned or flapping clothing such as ties, torn clothes, scarves, open jackets or shirts with open zips which could get caught into moving parts.

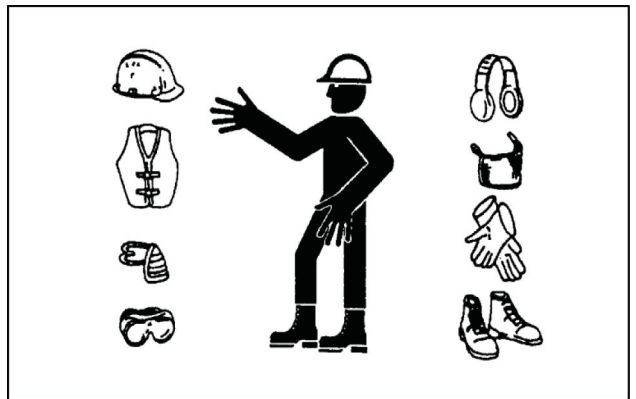

TULI12WEX2008AA 4

Engine - Radiator

Never leave the engine running in enclosed spaces without proper ventilation which is able to evacuate toxic exhaust gases- Keep the exhaust manifold and tube free from combustible materials.

Do not refuel with the engine running, especially if hot, as this increases fire hazard in case of fuel spillage.

Never attempt to check or adjust the belts when the engine is running.

Never lubricate the machine with the engine running.

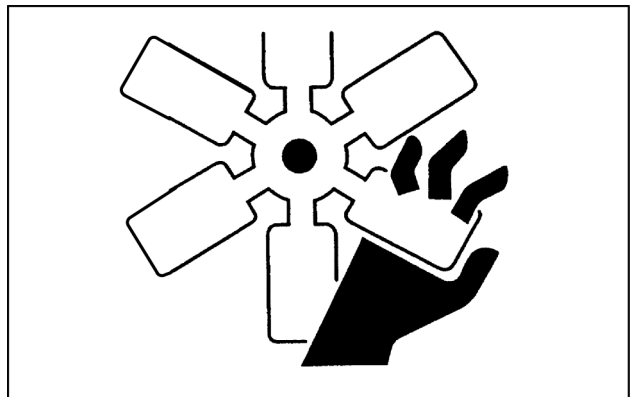

TULI12WEX2009AA 5

Product identification - Identification of machine components

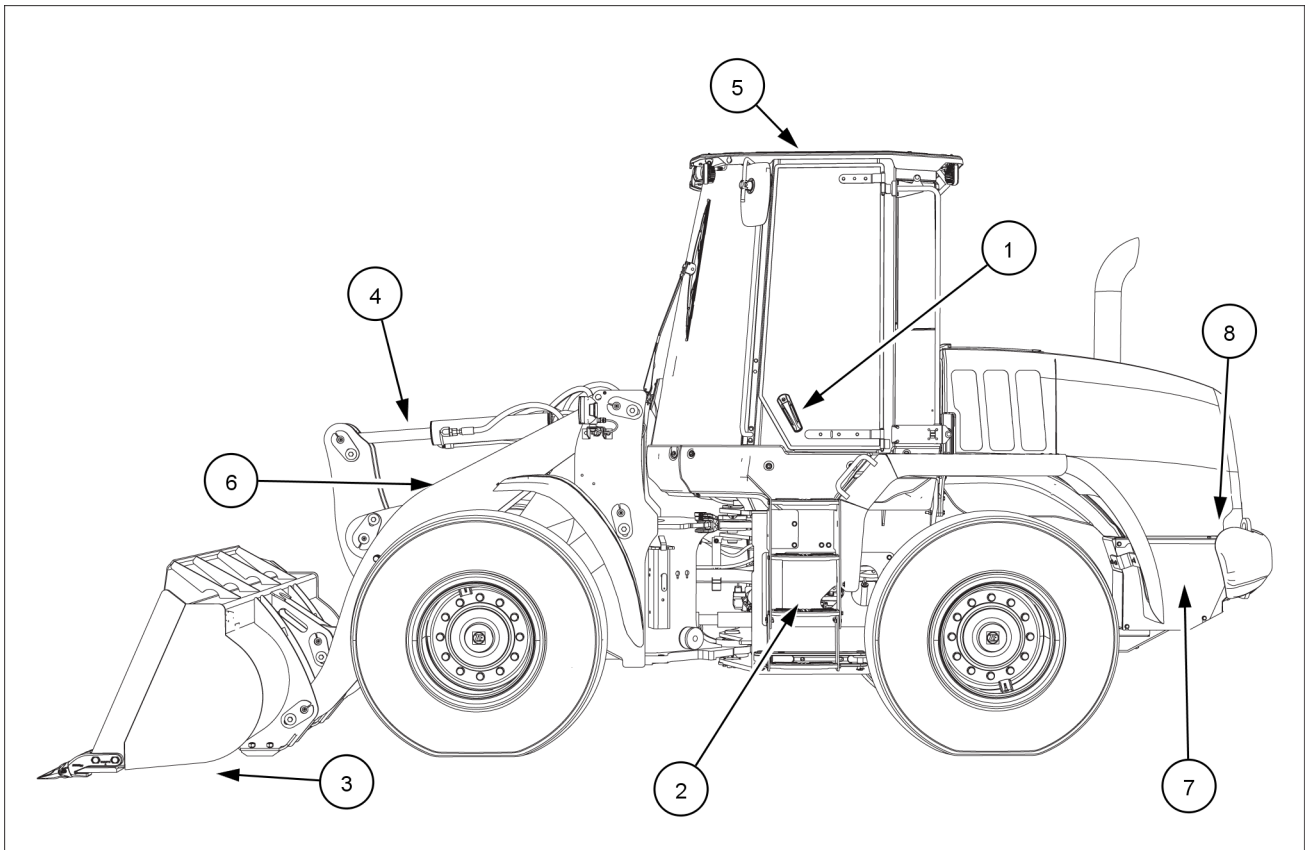

LEIL16WHL2491FA 1

- | | |
|----------------------------|---|
| 1. Cab door and hand holds | 5. Roll Over Protection System (ROPS) cab |
| 2. Steps | 6. Loader lift arm |
| 3. Bucket (Z-bar version) | 7. Battery compartment |
| 4. Bucket cylinder | 8. Timed disconnect switch and optional battery jump post |

INTRODUCTION

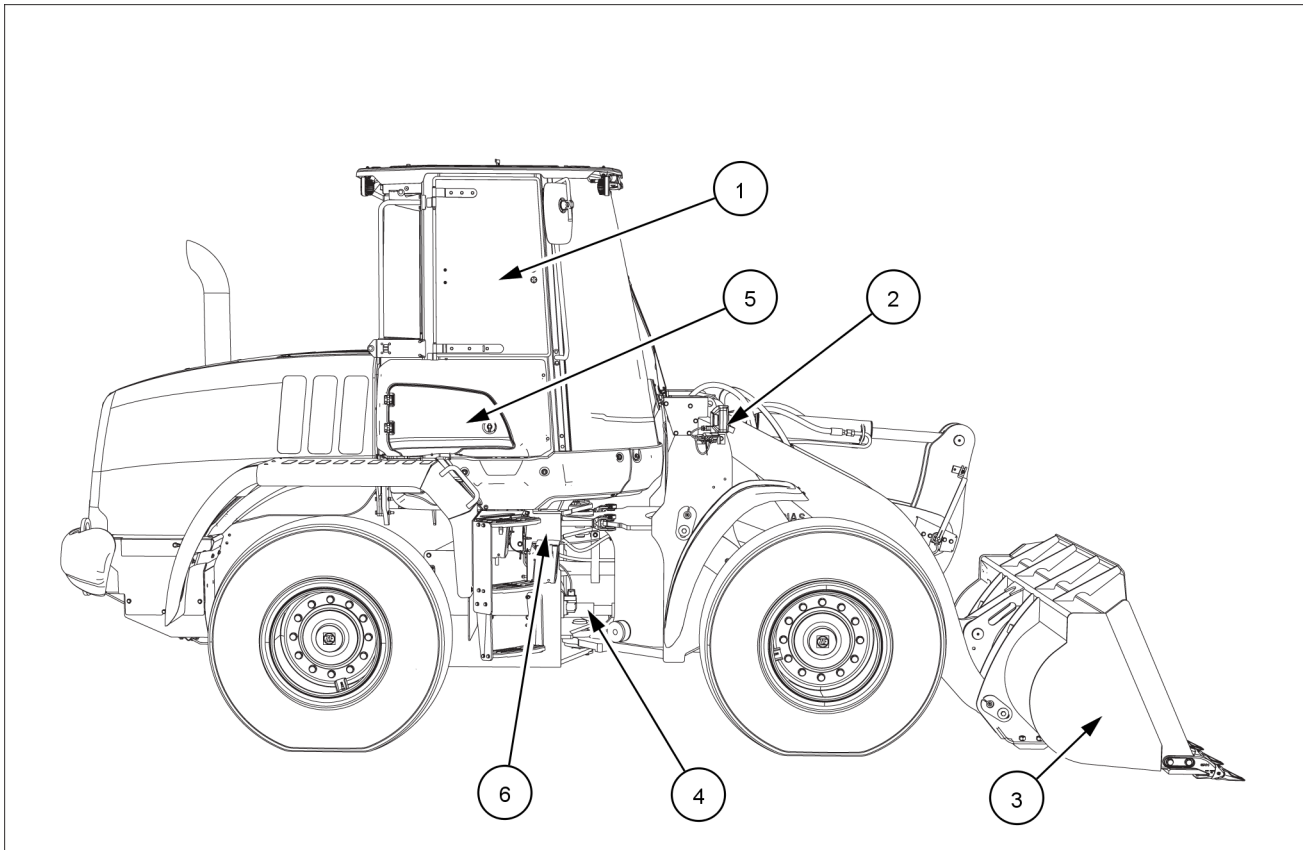

LEIL16WHL2492FA 2

- | | |
|---------------------------|--------------------------------|
| 1. Cab side window | 4. Drive shaft |
| 2. Driving lights | 5. Cab air filter door |
| 3. Bucket (Z-bar version) | 6. Windshield washer reservoir |



SERVICE MANUAL

Engine

521G XT - EH, NEW CAB TIER2 [FNH0521GNGHE00001 -]
521G ZBAR - EH, NEW CAB TIER2 [FNH0521GNGHE00001 -]

Engine - General specification

Engine with 4 Speed Transmission	
A. Low idle	1020 – 1080 RPM
Alternate low idle	870 – 930 RPM
Alternate accelerated idle	1270 – 1330 RPM
Working idle (setting from factory)	1120 – 1180 RPM
B. Maximum No Load RPM	2075 – 2245 RPM
C. Converter Stall	1950 – 2030 RPM
D. Hydraulic Stall	1900 – 2100 RPM
E. Converter & Hydraulic Stall	1400 – 1600 RPM
Temperature of the torque converter oil	82 – 104 °C (180 – 219 °F)
Temperature of the hydraulic oil	54 – 57 °C (129 – 135 °F)

NOTE: hydraulic stall and converter and hydraulic stall RPM values are read with the lift arms raised, the bucket held in rolled back position, and the engine at Wide Open Throttle (WOT) in maximum power mode with the transmission in manual mode and in third gear.

Engine - Remove

1. Park the machine on a level surface and lower the bucket to the ground. Put the articulation lock in the LOCKED position.

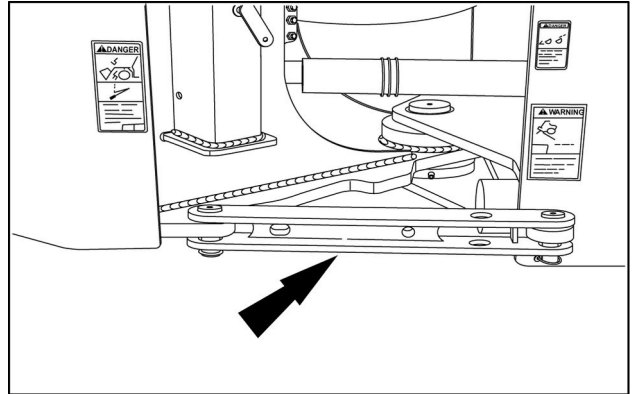

RAPH12WEL1412AA 1

2. Turn the engine OFF. Actuate the brake pedal several times to discharge the brake accumulators.

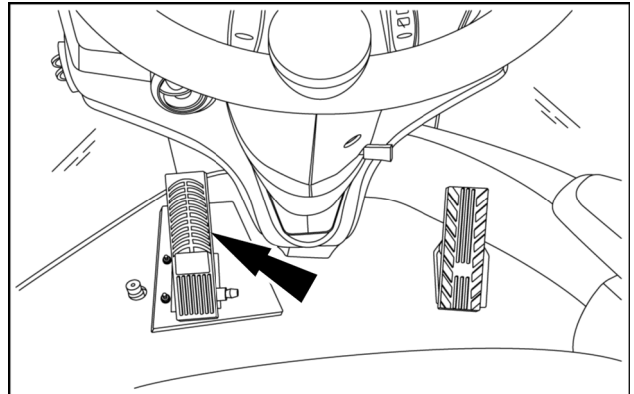

LEIL15WHL0564AA 2

3. Turn the key switch to the ON position. Move the control lever(s) back and forth minimally 30 times to release pressure from the hydraulic circuit. Put the key switch to the OFF position.

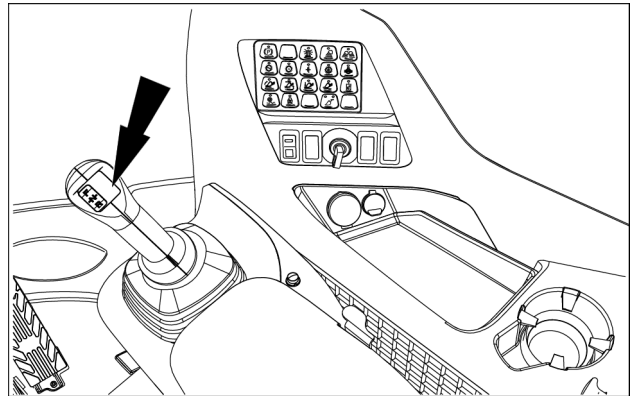

LEIL16WHL1286AA 3

4. Slowly loosen the hydraulic reservoir filler cap to release air pressure in the hydraulic reservoir.

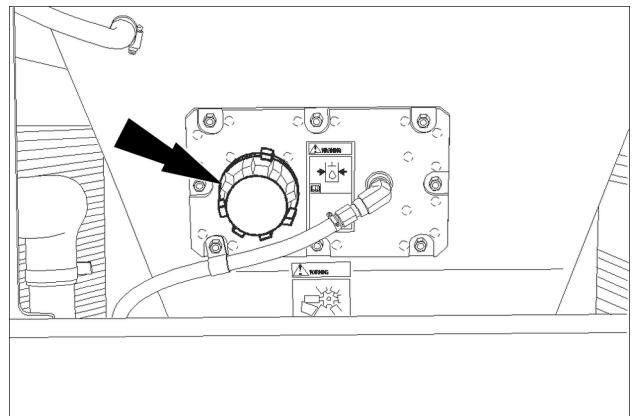

RCPH10WHL099BAL 4

5. Raise the engine hood using the handle hood under the rear grill.

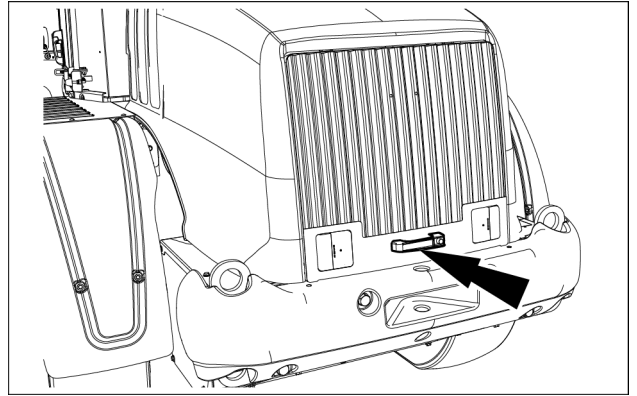

LEIL17WHL0059AB 5

6. Remove the bracket (3) to separate the wide fender (1) from the rear fender (2).

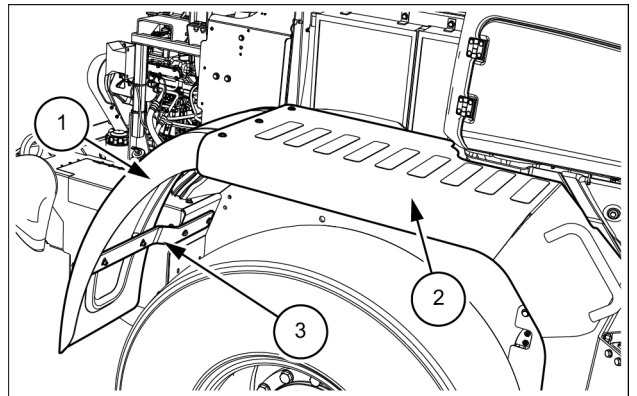

LEIL17WHL0145AB 6

7. Remove the retaining bolts (1) and (2) of the inner fender panel (3).

NOTE: right-hand side of the machine is shown. The operation is similar for the left-hand side.

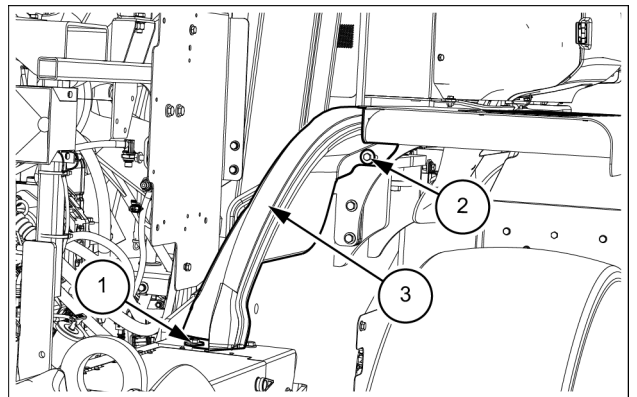

LEIL17WHL0146AB 7

8. Locate the timed disconnect switch under the engine hood, on the left-hand side of the machine. Turn the timed disconnect switch to the OFF position.

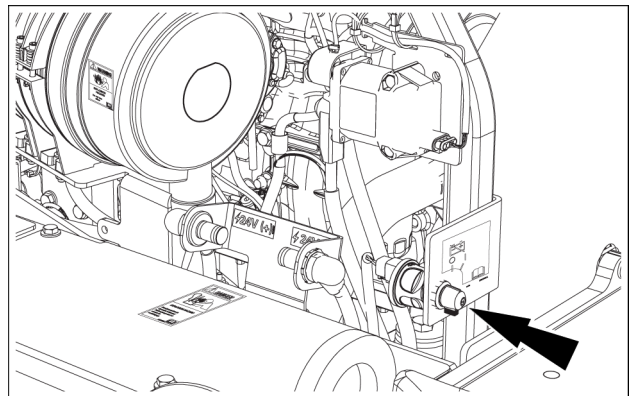

LEIL16WHL2685AA 8

9. Remove the two battery covers. Disconnect the batteries from the machine.

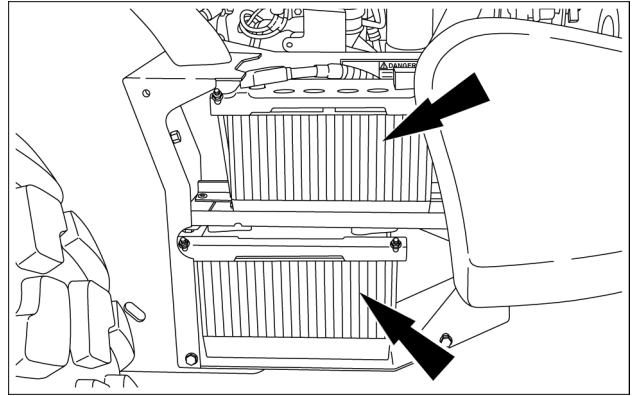

LEIL16WHL1225AA 9

10. Loosen the screw (1) and open the access cover (2) under the battery.

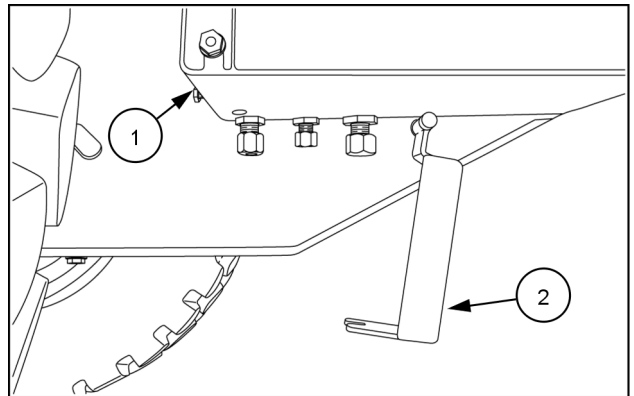

RAPH12WEL1494AA 10

11. Place a suitable container below the radiator drain. Remove the drain plug (1) and radiator cap to drain the engine coolant into the container. then reinstall the radiator cap after the coolant has drained.

NOTE: see machine specifications for cooling system volume.

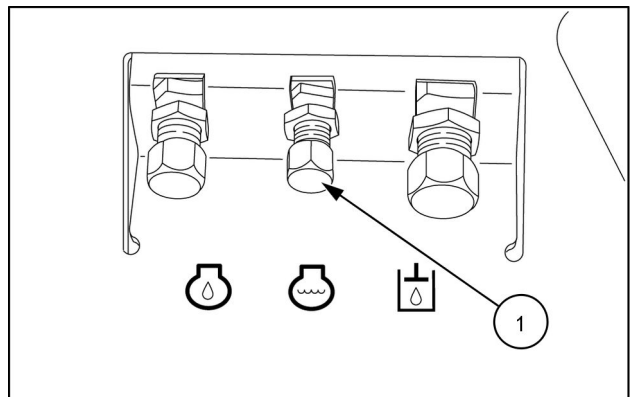

RAPH12WEL1411AA 11

12. Place a suitable container below the engine oil drain. Remove the engine oil cap (2) to drain the engine oil into the container. Then reinstall the engine oil cap after the engine oil has drained.

NOTE: see machine specifications for cooling system volume.

NOTE: after draining the engine oil, disconnect the drain hose from the frame to aid in removal of engine.

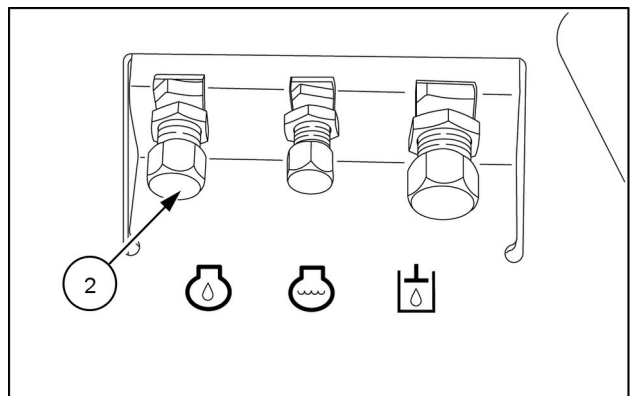

RAPH12WEL1411AA 12

13. Double up a nylon lifting strap and slide the strap through the exhaust stack (1), located on the engine hood.

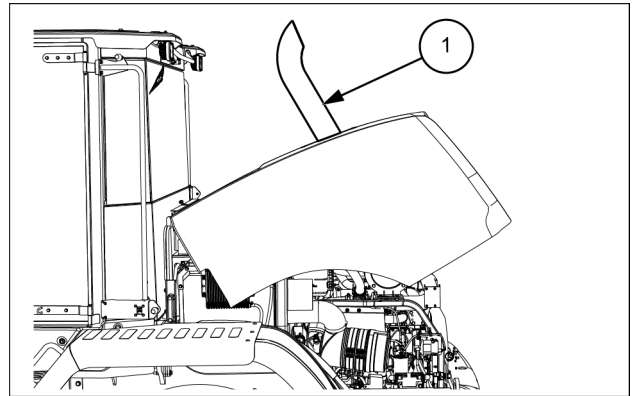

LEIL17WHL0056AB 13

14. Place a solid steel bar through the nylon strap. Raise the engine hood and release the tension on the lifting motor.

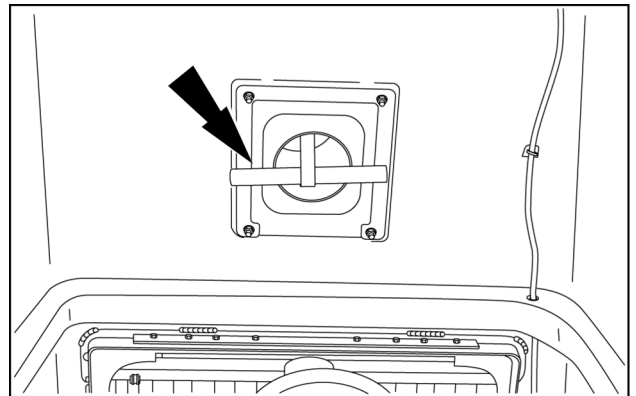

RAPH12WEL1458AA 14

15. Remove the right-hand gas strut from the engine hood.
Remove the left-hand gas strut from the engine hood.

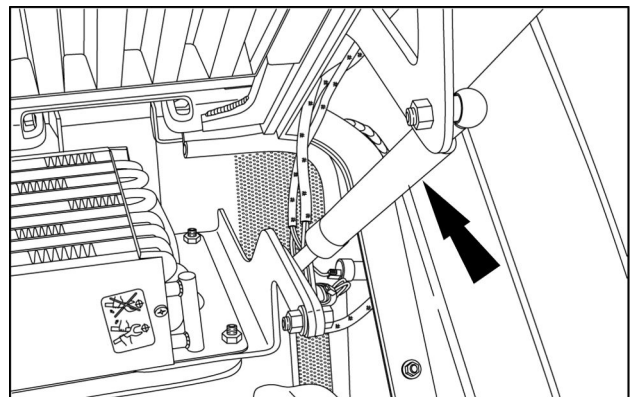

RAPH12WEL1489AA 15

16. Remove the gas spring to separate the engine hood from the rear chassis.

NOTE: engine hood is NOT shown.

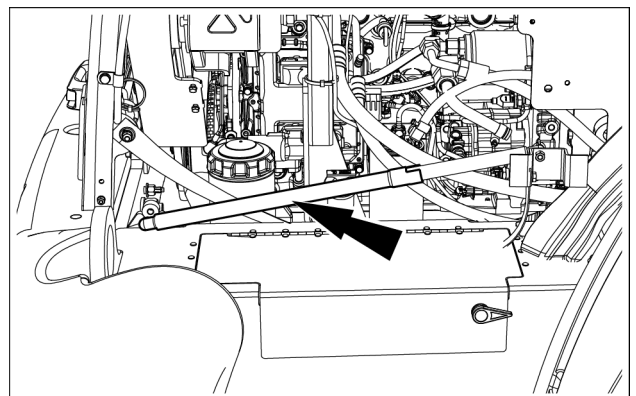

LEIL17WHL0058AB 16

17. Disconnect the hood wiring harness connector from the rear chassis wiring harness connector. Identify and tag the connectors to aid in reassembly.

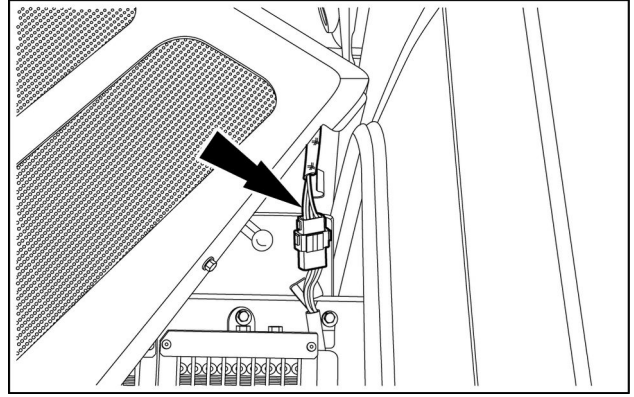

LEIL15WHL0142AB 17

18. Tag and disconnect the backup alarm connector (1). Remove the two straps cable tie (2).

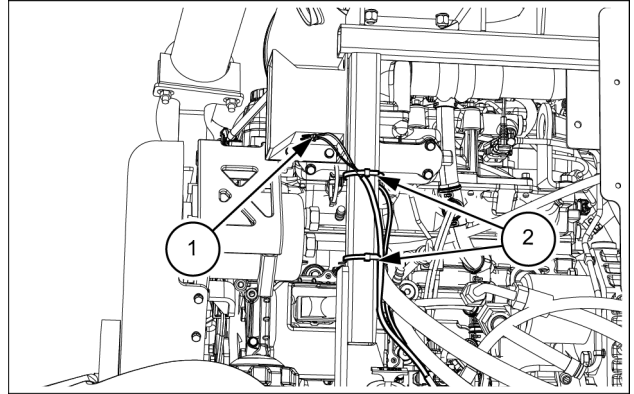

LEIL17WHL0149AB 18

19. Remove the connector (1) from the battery isolator.

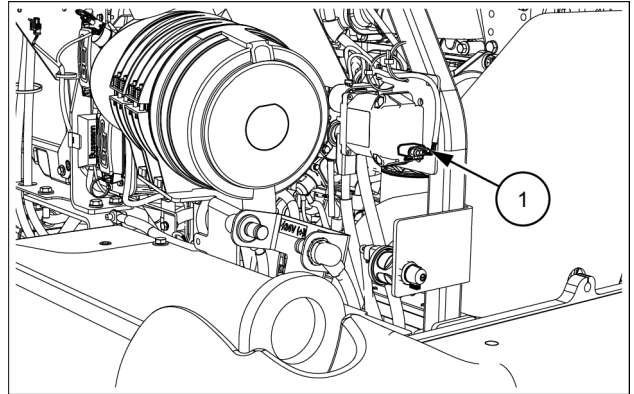

LEIL17WHL0147AB 19

20. Tag and disconnect the battery to isolator cable (1) and the isolator to starter cable (2) from the battery isolator. Disconnect the connector (3) from the timed disconnect switch.

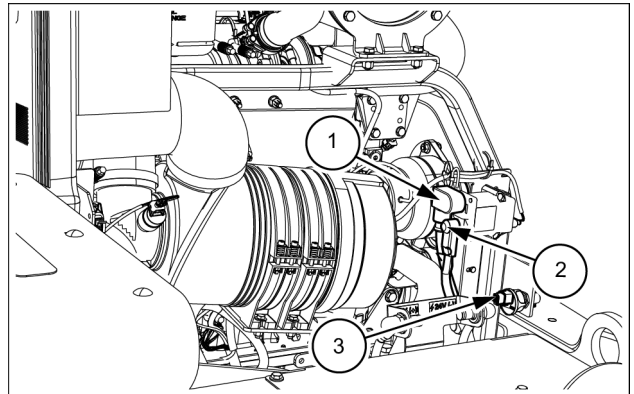

LEIL17WHL0148AB 20

21. With the assistance of another technician, balance the engine hood and remove the hood hinge mounting bolts (1) near the cab (2) from the cooler frame. Repeat the procedure for the other side.

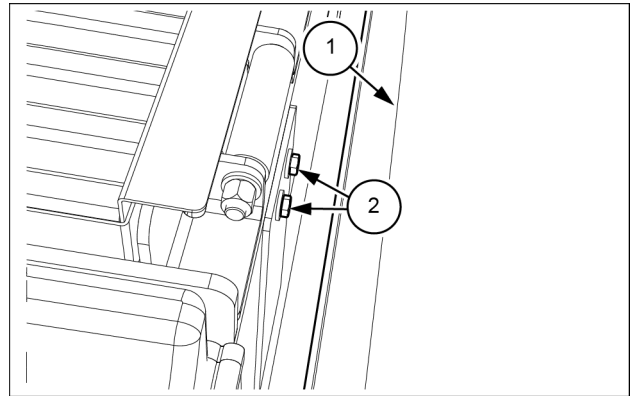

LEIL17WHL0057AB 21

22. Carefully raise and remove the engine hood from the machine. Lower the engine hood onto a suitable platform. Disconnect the lifting equipment from the exhaust stack (1).

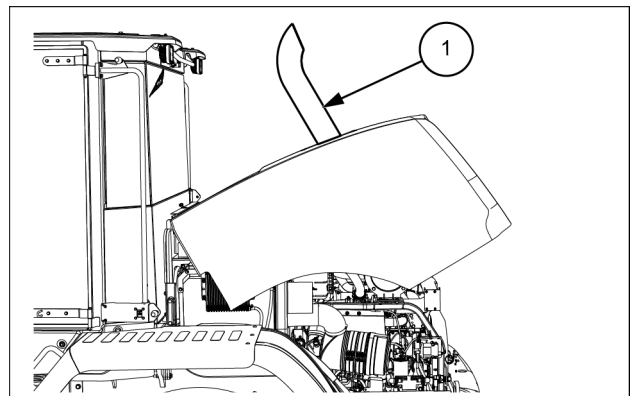

LEIL17WHL0056AB 22

23. Remove the four mounting bolts and the four washers securing the belt cover. Remove the belt cover.

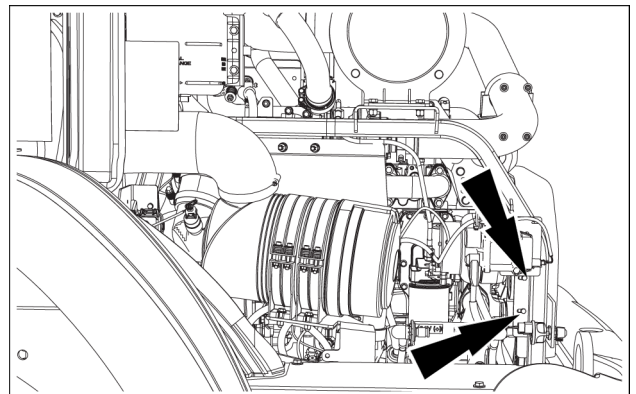

LEIL16WHL2688AA 23

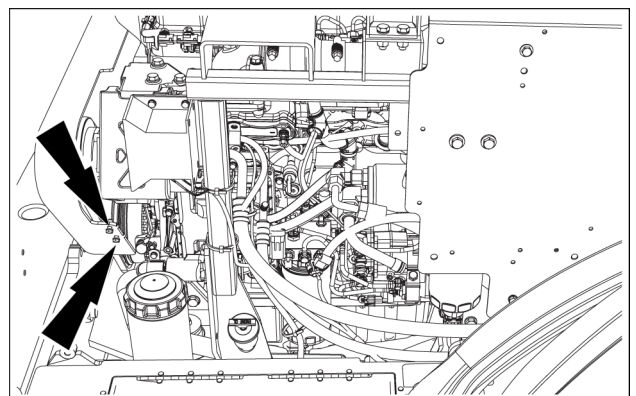

LEIL16WHL2687AA 24

24. If machine is equipped with the air conditioning system, identify, tag, and disconnect the engine wiring harness connectors from the air compressor (3). Recover the refrigerant, as indicated in **Air conditioning - Service instruction (50.200)**. Disconnect the low-pressure line (1) from the suction port and the high-pressure line (2) from the discharge port, located on the compressor. Immediately install protective caps on the open ports and lines.

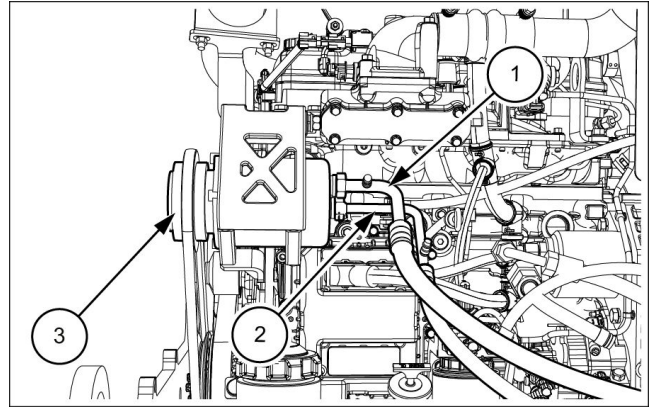

LEIL17WHL0006AB 25

25. Remove the V-belt (1). Remove the bolt M8x110 (9), the bolt M8x100 (8) and the washers (7). Remove the bolt M12x130 (1), the washers (3), the spacer (4), and the nut (5). Separate the air-conditioning compressor (6) from the support (10).

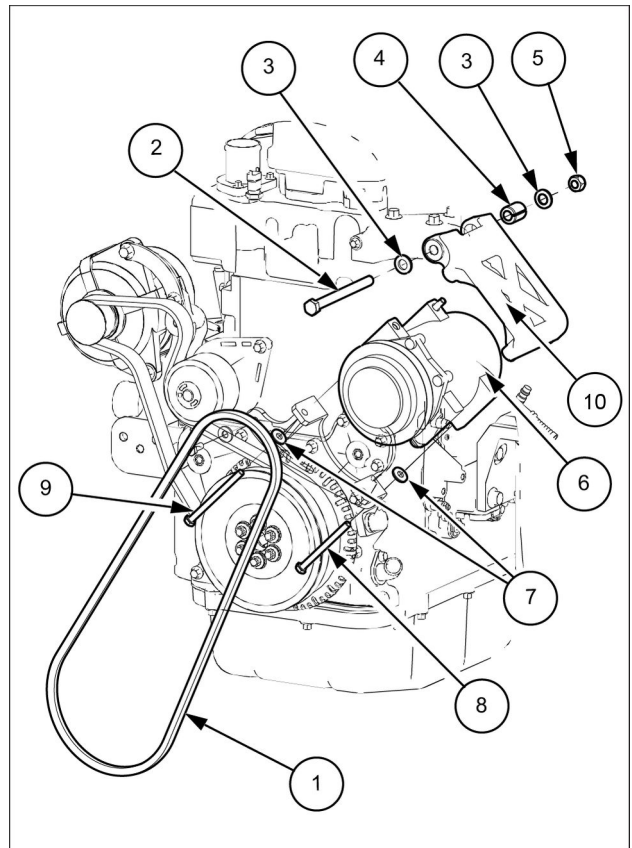

LEIL17WHL0007BB 26

26. Remove the drive belt from the engine.

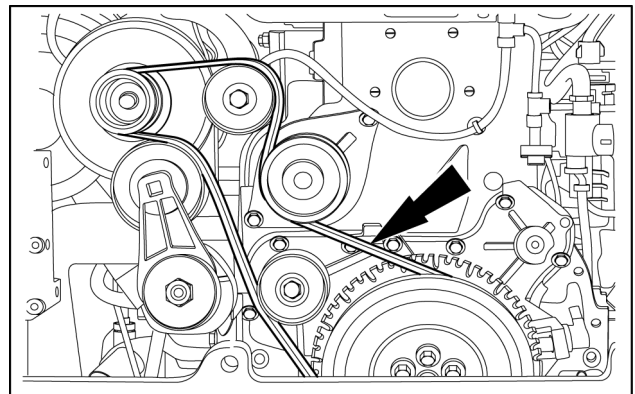

LEIL15WHL0192AB 27

27. Tag and disconnect the fuel filter heater wire (1) and the water sensor (2). Drain the fuel filter and disconnect the inlet fuel line (3) and outlet fuel line (4) from the fuel filter head. Plug the lines and cap the fittings.

NOTE: the fuel filter bracket has been hidden for clarify.

28. Remove the fuel line (5) from the top of the ECU (Engine Control Unit). Plug the line and cap the fitting.

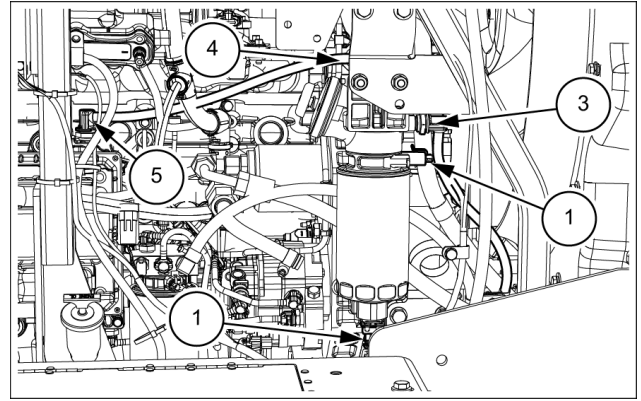

LEIL17WHL0210AB 28

29. Remove the bolts (2) with related washers to separate the fuel filter bracket (1) from the cooling frame.

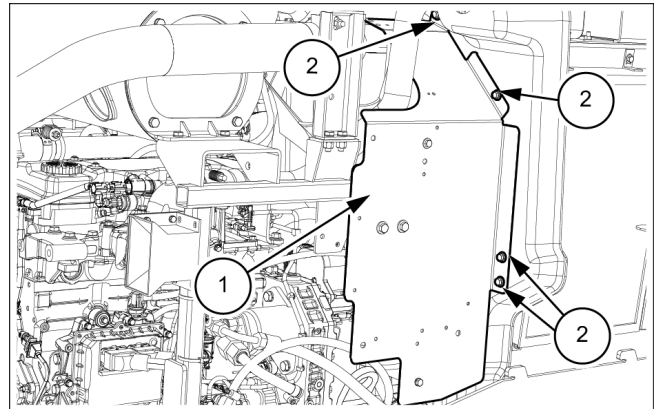

LEIL17WHL0209AB 29

30. Loosen the two bolts (2) and the related washers to remove the bracket (1) of the relay decal.

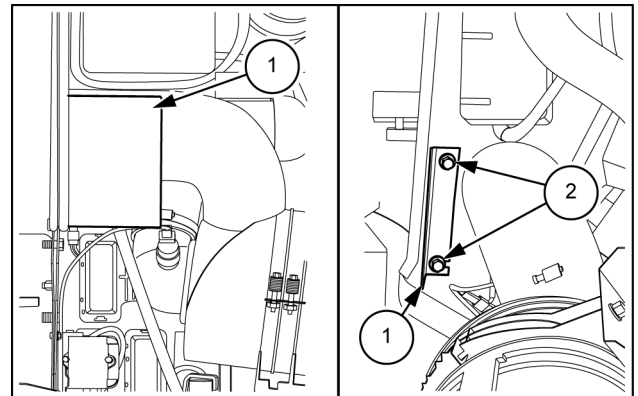

LEIL15WHL0195AB 30

31. Disconnect the additional fuses and relays (1).

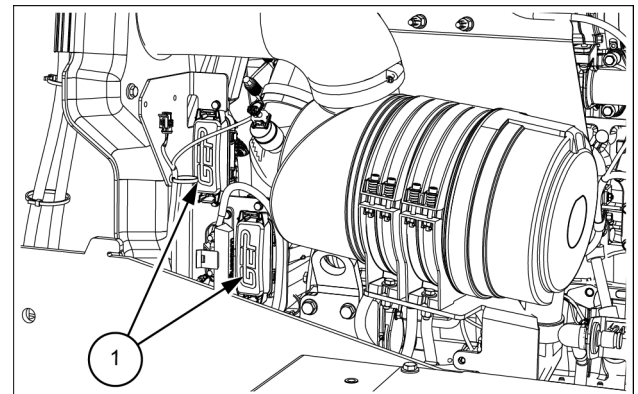

LEIL17WHL0214AB 31

32. Remove the ground wires from the bracket. **NOTE:** move the wiring harness away from the engine.

NOTE: move the wiring harness away from the engine compartment.

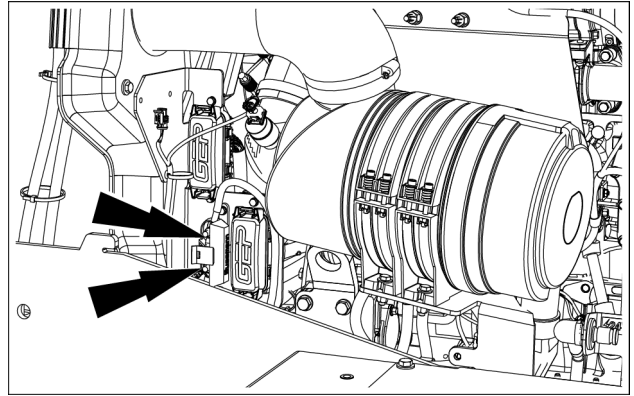

LEIL17WHL0216AA 32

33. Tag and disconnect the engine wiring harness connector from the air filter sensor (1). Loosen the clamp (2) on the air intake hose (3) and disconnect the hose.

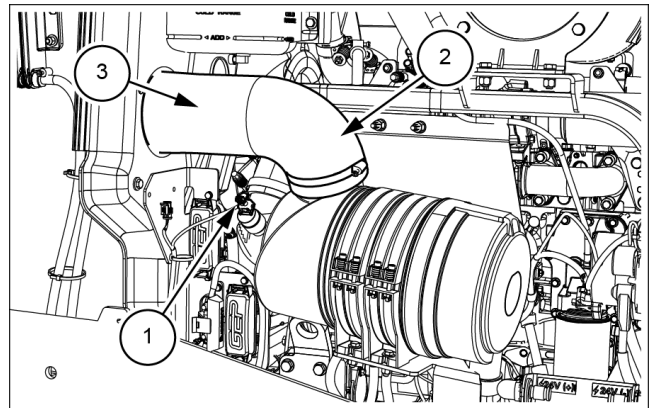

LEIL17WHL0174AB 33

34. Remove the clamp (2) and the clamp (3). Separate the clamp (4) from the bracket of the coolant overflow tank. Loosen the bolts (1) to remove the coolant tank.

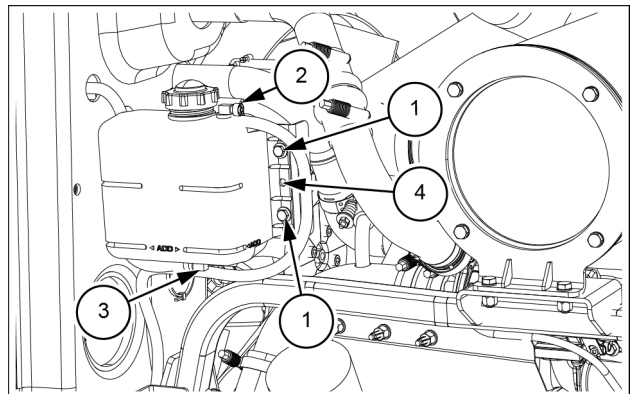

LEIL17WHL0150AB 34

35. Remove the bolts and the washers (2) to separate the bracket (1) of the overflow tank from the rear plate of the cooling system frame.

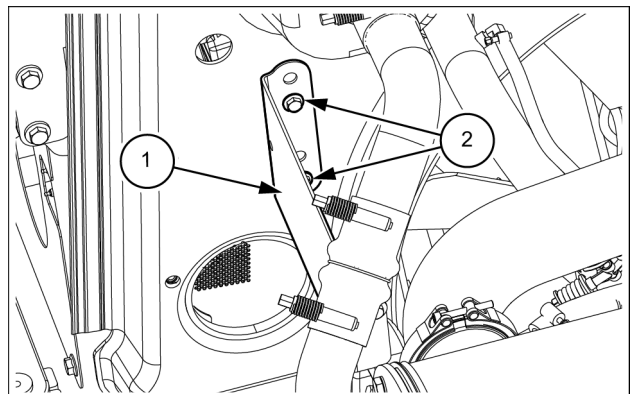

LEIL17WHL0151AB 35

36. Loosen the clamp **(1)**. Remove and discard the O-ring from the air intake tube of the turbocharger. Loosen the clamp **(3)**. Remove the after cooler inlet hose **(2)**.

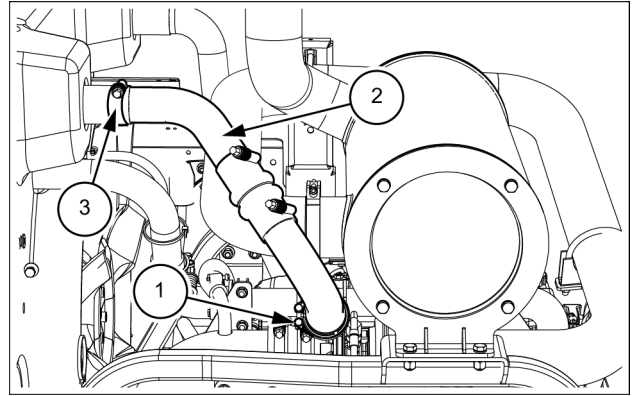

LEIL17WHL0152AB 36

37. Loosen the clamp **(1)** on the crankcase vent hose **(2)**.

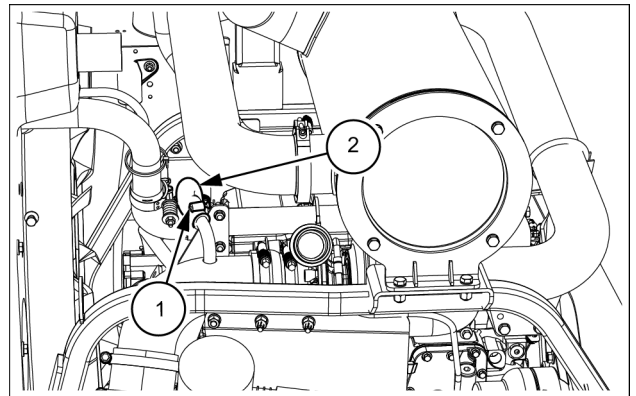

LEIL17WHL0153AB 37

38. Loosen the clamps **(2)** and **(3)** on the turbocharger.
 39. Loosen the clamps **(3)** on the air filter housing.
 40. Remove the intake air hose **(1)**. Cover the turbocharger inlet to prevent debris entry.

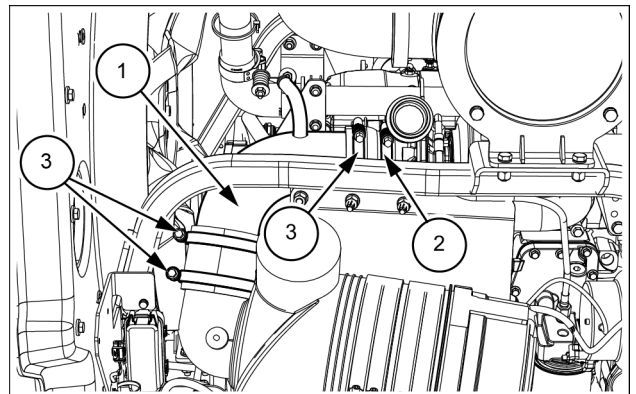

LEIL17WHL0154AB 38

41. Remove the securing bolts **(2)**, with related washers and nuts. Remove the bracket **(1)** with the air filter as an assembly.

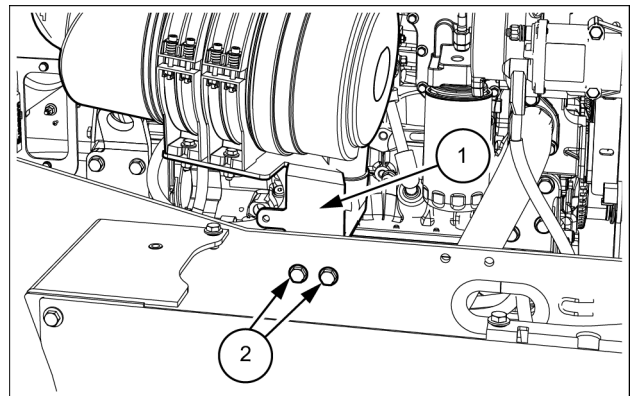

LEIL17WHL0175AB 39

42. Remove the nut **(2)** with related washers and bolt. Remove the heat shield **(1)**.

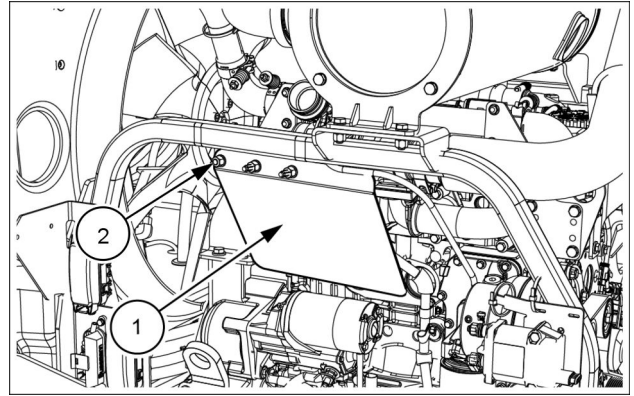

LEIL17WHL0171AB 40

43. Remove the bolts **(2)** with related washers to separate the muffler inlet pipe bracket **(1)** from the engine.

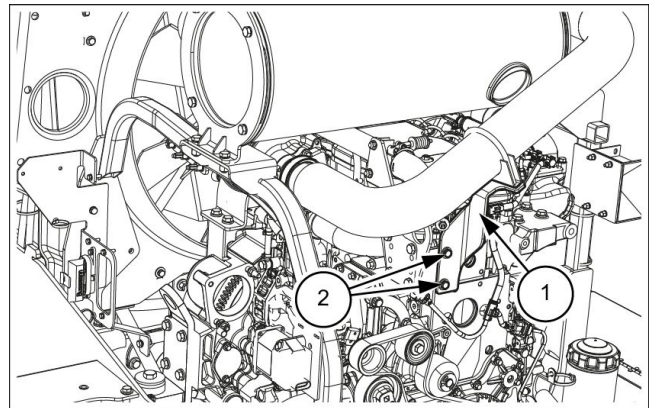

LEIL17WHL0208AB 41

44. Remove the clamp (arrow) to separate the muffler inlet pipe from the engine.

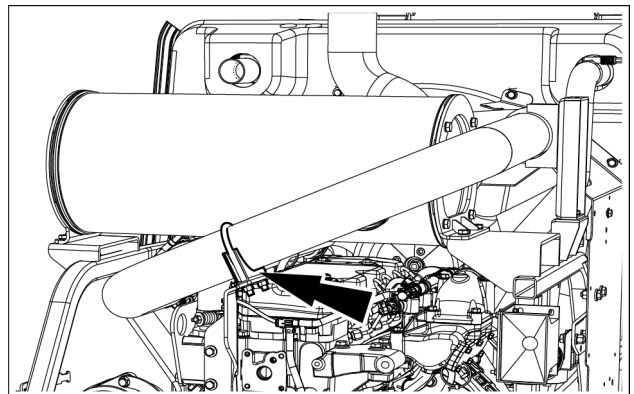

LEIL17WHL0177AB 42

45. Loosen the clamp to separate the engine from the inlet muffler pipe.

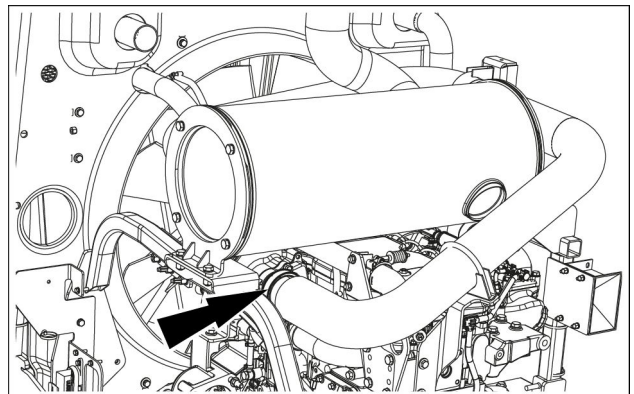

LEIL17WHL0176AB 43

46. Remove the bolt (2), with related clamp, washer and nut to separate the engine and rear chassis harness from the bracket (1). Remove the bolt (3). Remove the bracket (1) from the machine.

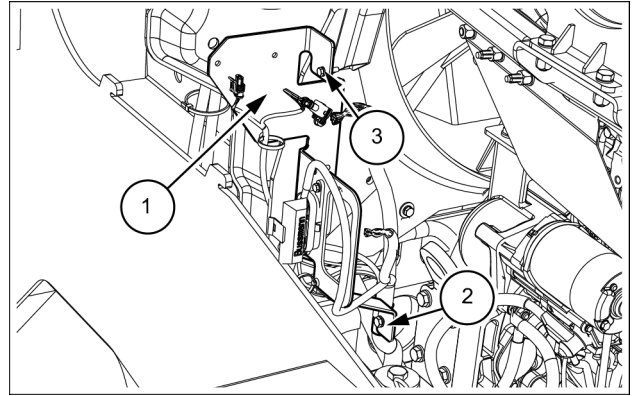

LEIL17WHL0246AB 44

47. Attach a suitable lifting straps to support the muffler support.
48. Remove the eight bolts with their related washers to separate the muffler support from the support structures.
49. Remove the muffler support, and the muffler as an assembly.

NOTE: do not damage the muffler support during removal.

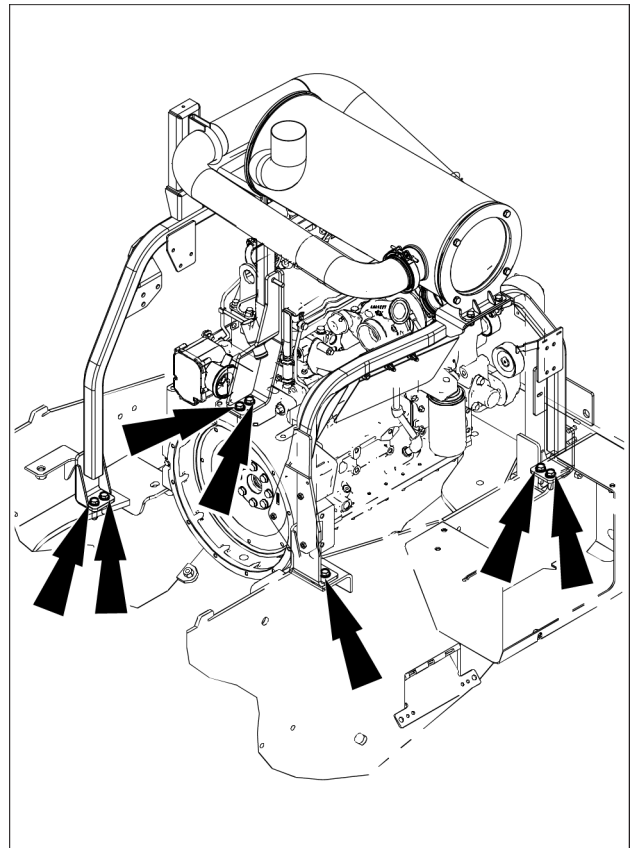

LEIL17WHL0178BB 45

50. Loosen the clamps **(1)** on the intake manifold that secures the after cooler output hose **(6)**.
51. Loosen the clamp **(7)** on the after cooler and remove the output hose **(6)** of the after cooler from the inter-cooler.
52. Cut the tie straps that hold the breather hose **(3)** from the radiator hose **(2)**. Remove the clamp **(4)**. Separate the breather hose **(3)** from the radiator hose **(2)**.
53. Remove the clamp **(9)** to separate the upper radiator hose **(8)** from the radiator hose **(2)**.
54. Remove the U-bolt clamps **(1)** and remove the radiator hose **(2)**.

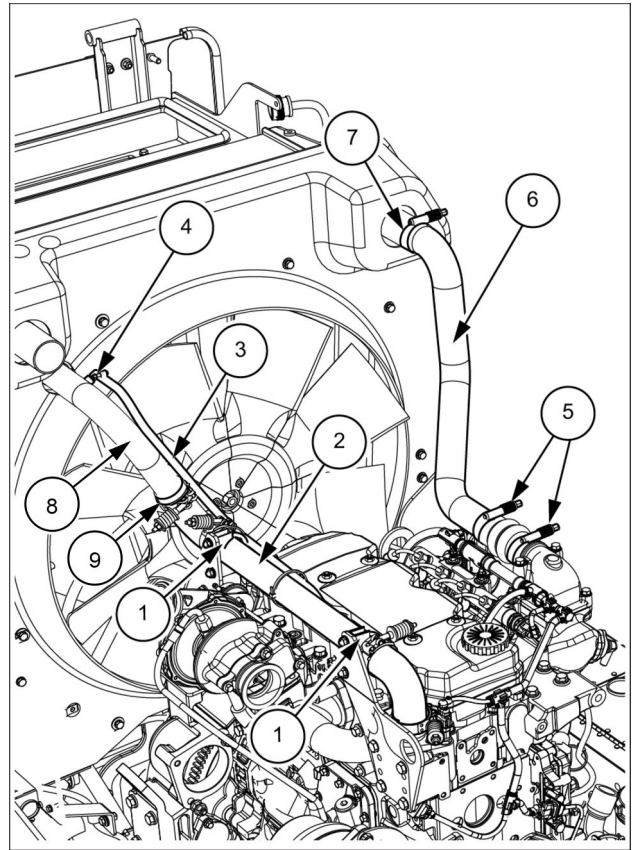

LEIL17WHL0180BB 46

55. Loosen the clamp **(1)** to separate the upper radiator hose **(2)** from the intercooler. Loosen the two U-bolt clamps **(3)**

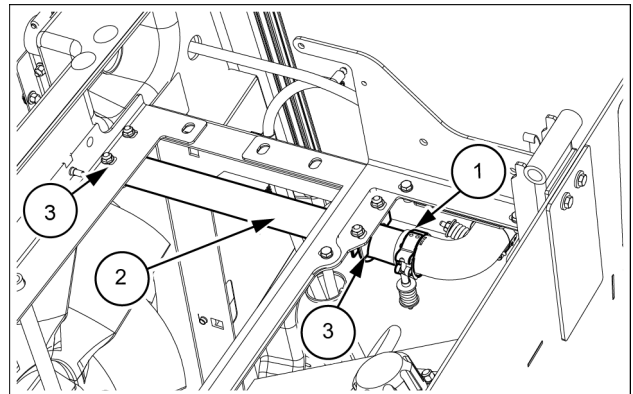

LEIL17WHL0244AB 47

56. Remove the clamp **(1)** and separate the breather hose **(2)** from the engine.

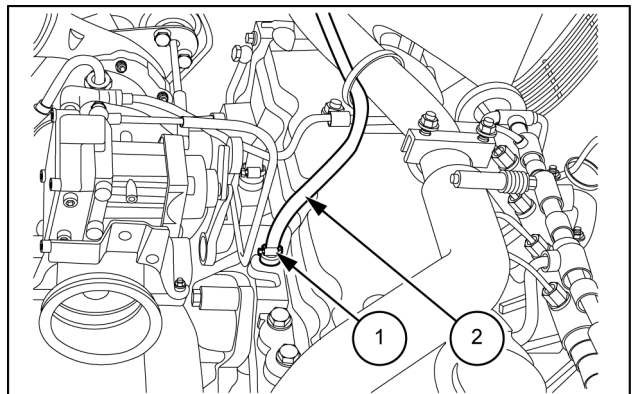

LEIL15WHL0291AB 48

57. Remove the bolts (1) to separate the bracket (2) from the engine.

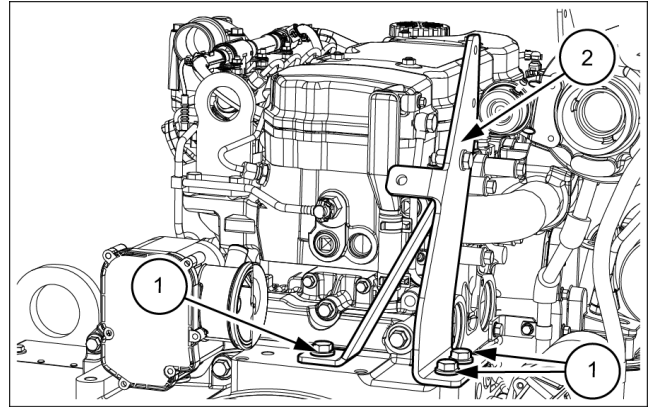

LEIL17WHL0211AB 49

58. Loosen the clamps (1) and (2) to remove the bottom hose coolant (3) from the engine.

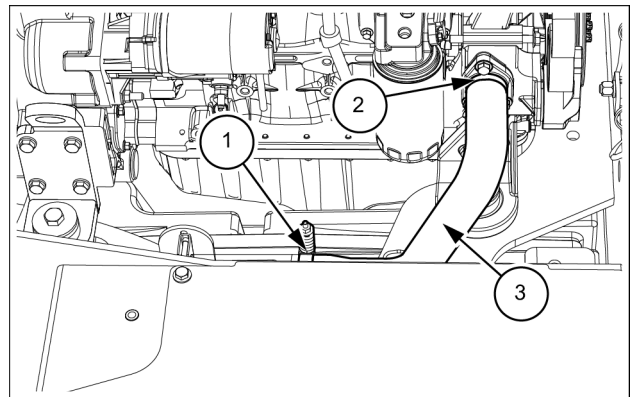

LEIL17WHL0212AB 50

59. Tag and remove the grid heater cable.

NOTE: hold the rear nut with a second wrench to prevent grid heater damage.

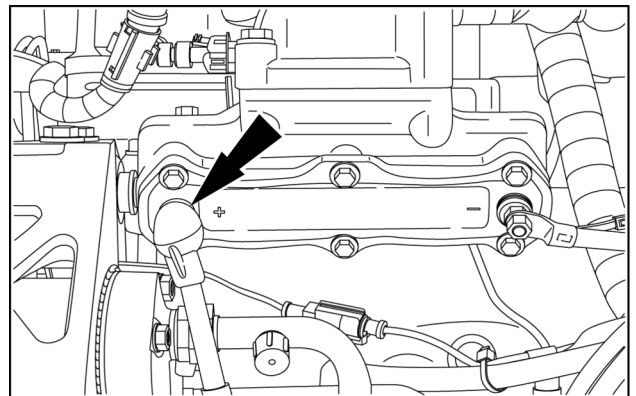

RAPH12WEL1478AA 51

60. Disconnect the wiring from the alternator. Identify and tag the wires to aid in reassembly.

NOTE: move the wires away from the engine.

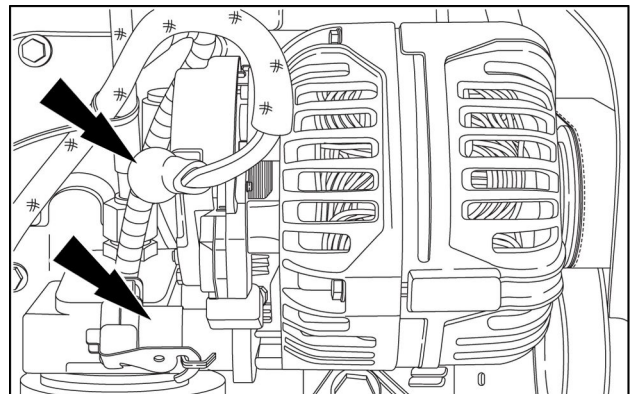

RAPH12WEL1468AA 52

61. Disconnect the wiring harnesses from the ECU controller.

NOTE: *lifting up on the lever will release the connector from the controller.*

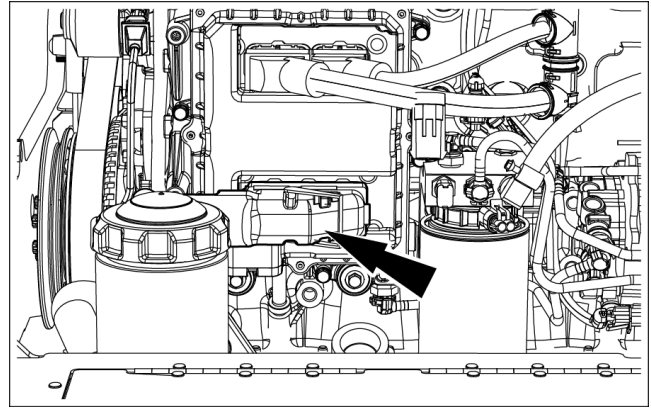

LEIL17WHL0215AB 53

62. Place identification tags on the cables to aid in re-assembly. Remove the negative cable (starter to ground) (1), the negative cable (battery to starter) (2) from the engine starter. Remove the positive cable (battery isolator to starter) (3) and the connectors (4) and (5) from the engine starter.

NOTE: *move the starter cables away from the engine.*

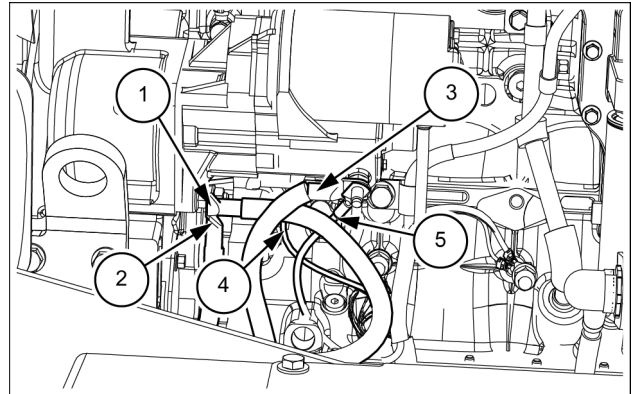

LEIL17WHL0172AB 54

63. Tag and disconnect wire harness (2) from the primary fuel filter (1).

64. Remove the fuel line (3) from the top of the primary fuel filter (1). Plug the line and cap the fitting.

NOTE: *make note on how fuel lines are routed.*

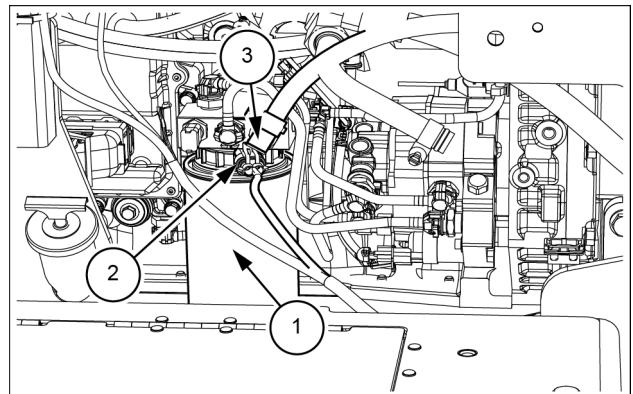

LEIL17WHL0173AB 55

65. Remove the bolts securing the wiring harness clamps to the engine.

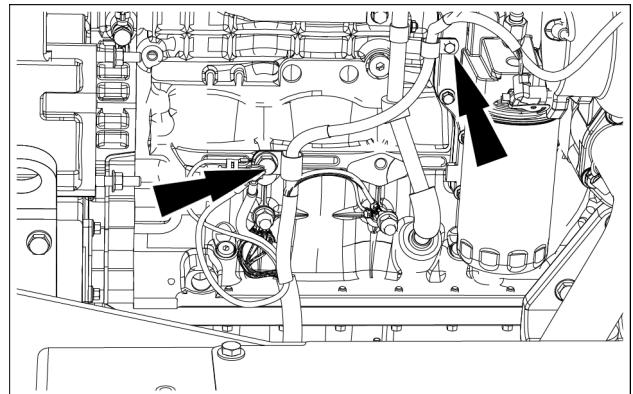

LEIL17WHL0213AA 56

66. Remove the ground wires from the engine

NOTE: move the wiring harness away from the engine.

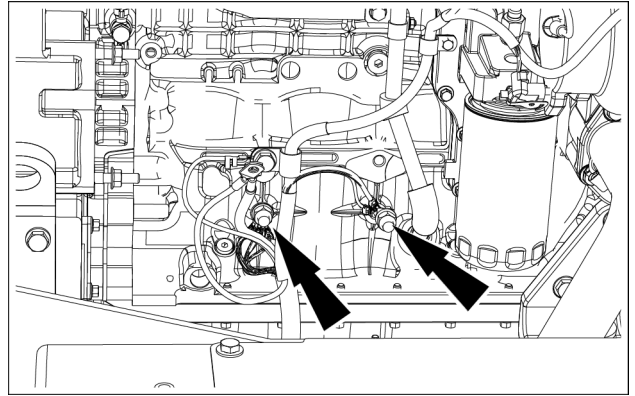

LEIL17WHL0213AA 57

67. Connect a vacuum pump to the hydraulic reservoir. Turn the vacuum on. Tag and remove the hydraulic lines from the brake system pump. Plug the lines and cap the fitting.

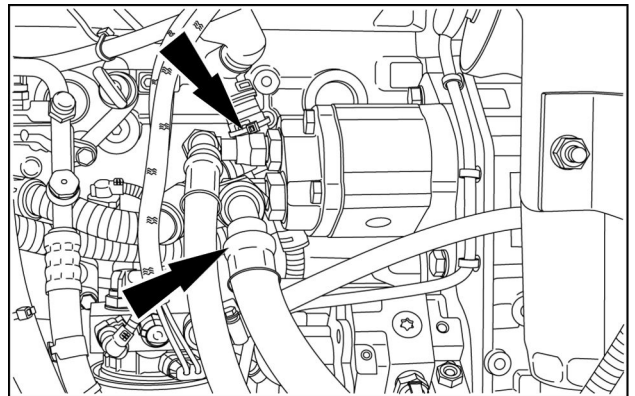

RAPH12WEL1480AA 58

68. Remove the lower cover of the drive shaft.

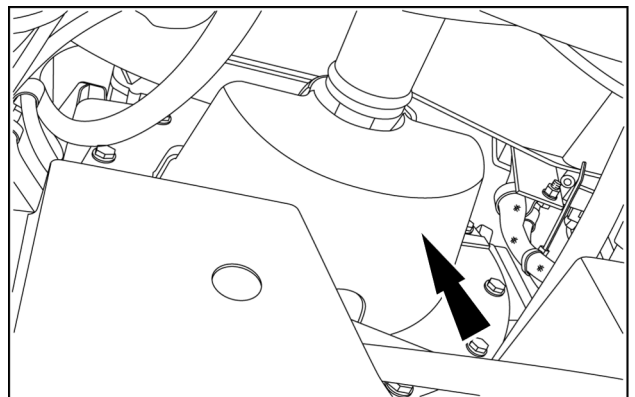

RAPH12WEL1481AA 59

69. Remove the drive shaft bolts from the flywheel. Move the drive shaft clear of the flywheel.

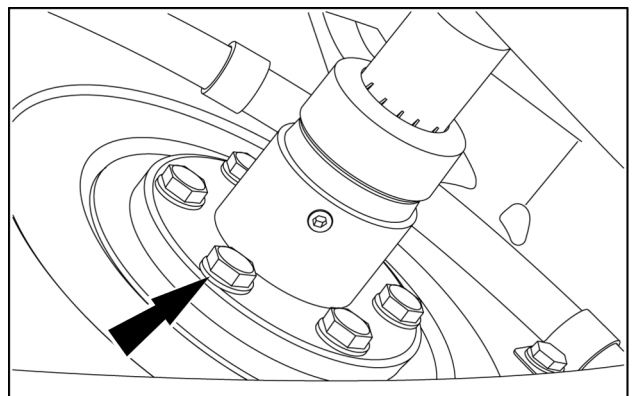

RAPH12WEL1421AA 60

70. Connect a suitable lifting equipment to the engine lifting brackets **(2)**. Take up all slack in lifting equipment. Remove the four engine mounting bolts **(1)**.
71. Slowly raise engine from rear chassis. Be sure that all the wire harness connections and the hoses have been disconnected and are clear of the engine. Guide the oil drain hose from the frame as the engine is lifted. Remove the engine from machine.

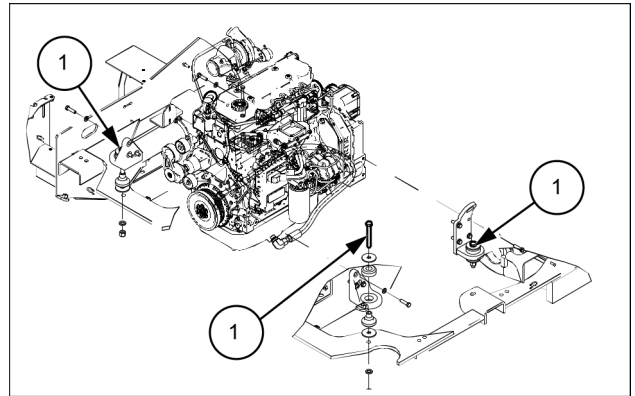

LEIL17WHL0207AB 61

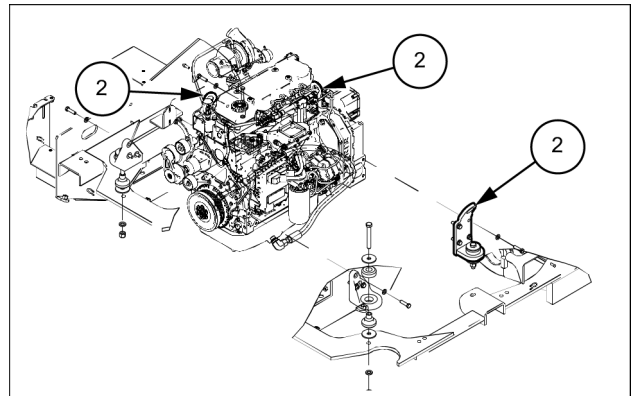

LEIL17WHL0179AB 62

Engine - Install

⚠ WARNING

Hot liquid under pressure!

Never remove the filler cap or the recovery tank cap while the engine is running or the coolant is hot. Let the system cool. Turn the filler cap to the first notch and allow any pressure to escape, and then remove the filler cap. Loosen the recovery tank cap slowly to allow any pressure to escape.

Failure to comply could result in death or serious injury.

W0296A

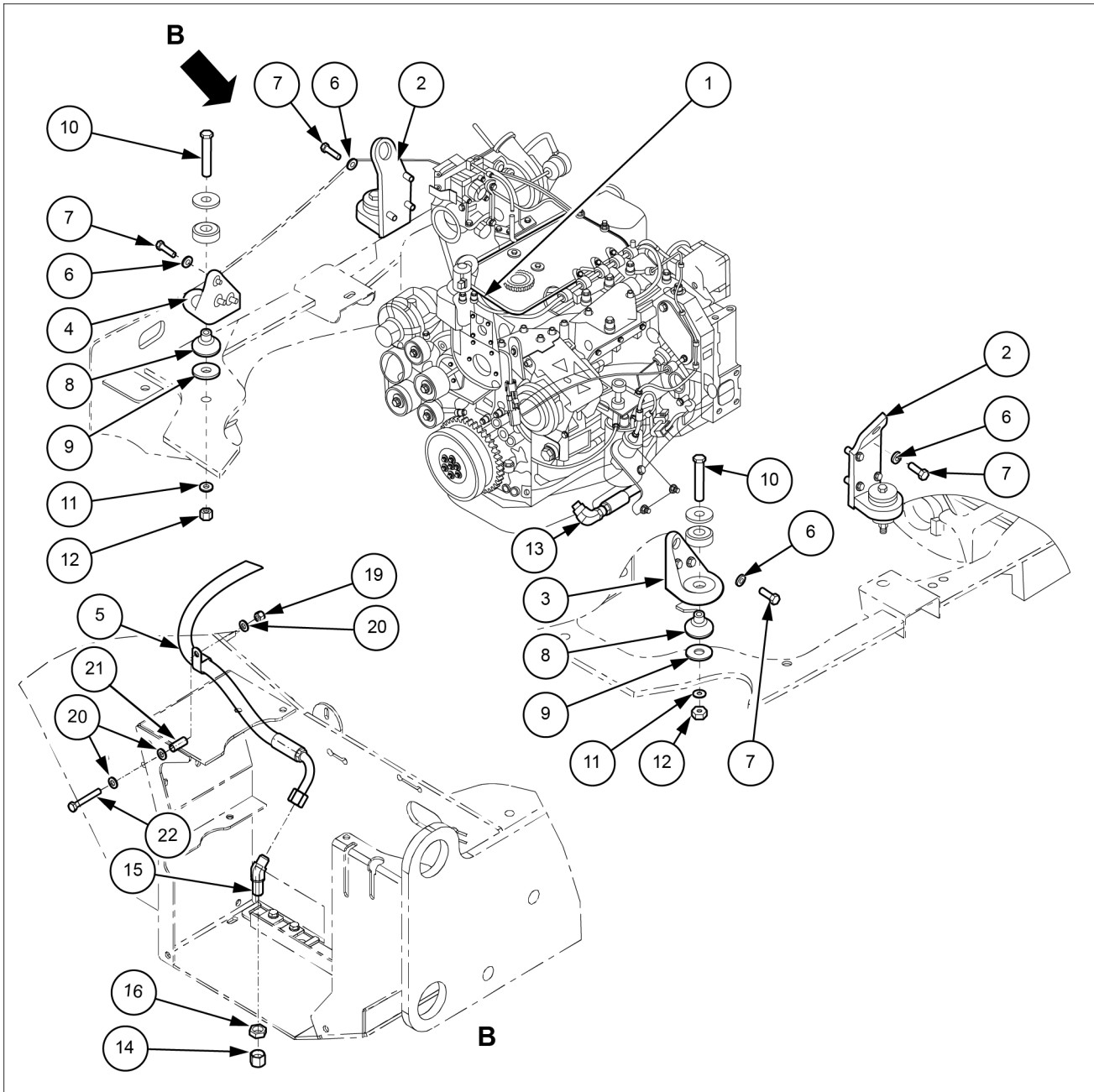

LEIL16WHL1341GB 1

- | | |
|--|-----------------------------|
| 1. Engine | 12. Nut M16 |
| 2. Engine mount | 13. 90° elbow. |
| 3. Engine rear mount (right-hand side) | 14. Tube cap |
| 4. Engine rear mount (left-hand side) | 15. 45° elbow. |
| 5. Oil fill tube | 16. Nut |
| 6. Washer 13.5 x 24 x 3 mm | 17. Upper isolator |
| 7. Bolt M12x45 | 18. Anchorage point |
| 8. Lower isolator | 19. Nut |
| 9. Washer .656 x 2.500 x .188 in | 20. Washer 11 x 21 x 2.5 mm |
| 10. Engine mount bolt | 21. Spacer |
| 11. Washer 17.5 x 30 x 40 mm | 22. Bolt M10 x 70 |

1. Inspect the engine mounts (2). If the engine rubber isolators require replacement, remove and discard the isolators (8) and (17). Install new rubber lower isolator (8), then upper isolator (17).
2. Attach suitable lifting equipment to the engine mounts (2) and point (18) and slowly move it into position over the rear chassis. Be sure all harness connections and hoses are out of the way or positioned correctly for reconnecting, before lowering engine.
3. Install washer (9) between the lower isolator (8) and the chassis. Install washers (5), engine mounting bolts (10), washers (11), and nuts (12) in engine isolators. Carefully lower and set engine in place.
4. Tighten the mounting bolts (10) of the engine to a torque of **244 – 298 N·m (180 – 220 lb ft)**.
5. Disconnect lifting equipment from the engine lifting brackets.
6. Connect the engine oil drain hose to the engine frame bracket.
7. At the front of the engine, position drive shaft on the engine coupling. Apply **LOCTITE® 242®** to six bolts and install to secure the drive shaft to the engine coupling. Tighten the bolts to torque of **53 – 62 N·m (39 – 46 lb ft)**.

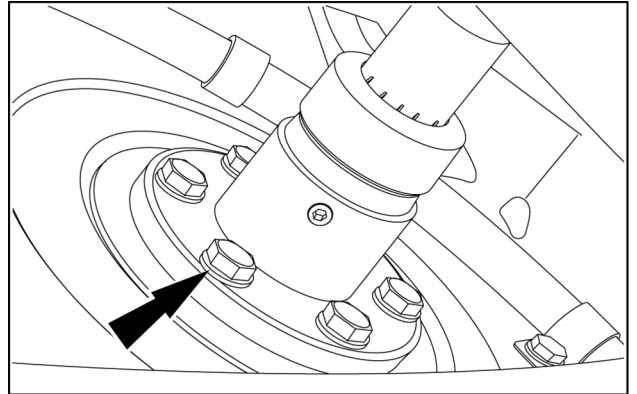

RAPH12WEL1421AA 2

8. Install the lower cover for the drive shaft.

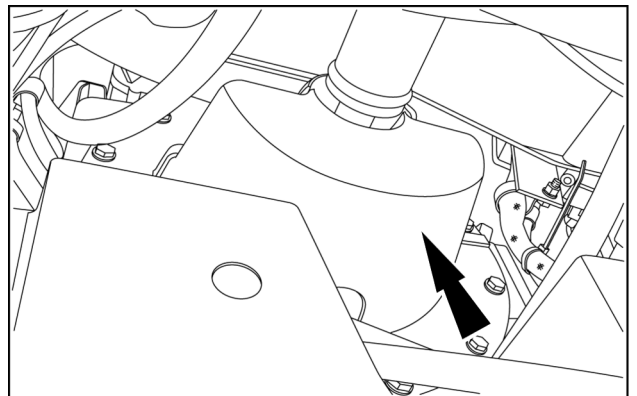

RAPH12WEL1481AA 3



Suggest:

If the above button click is invalid.

Please download this document

first, and then click the above link

to download the complete manual.

Thank you so much for reading

9. Connect a vacuum pump to the hydraulic reservoir. Turn the vacuum on. Remove plugs from the lines and caps from the fittings. Connect hydraulic lines to the brake system pump. Refer to marked tags to ensure lines are correctly installed. Turn off the vacuum pump and disconnect from the hydraulic reservoir.

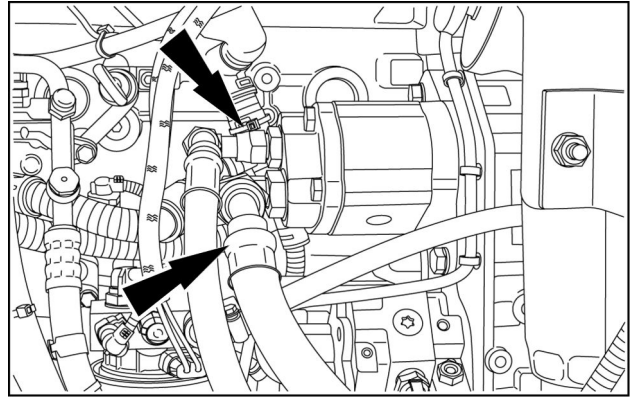

RAPH12WEL1480AA 4

10. Remove the plug from the fuel line (3) and the cap from the fitting. Connect the fuel line (3) to the primary fuel filter head.

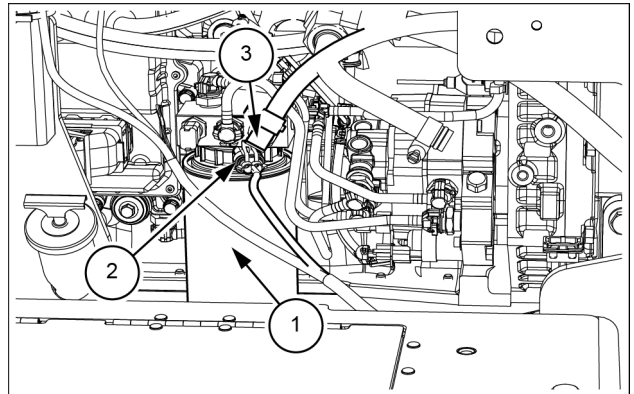

LEIL17WHL0173AB 5

11. Connect the wiring harness to the ECU.

NOTE: start the connector on the ECU with lever straight out from the ECU. Use lever to pull connector into position.

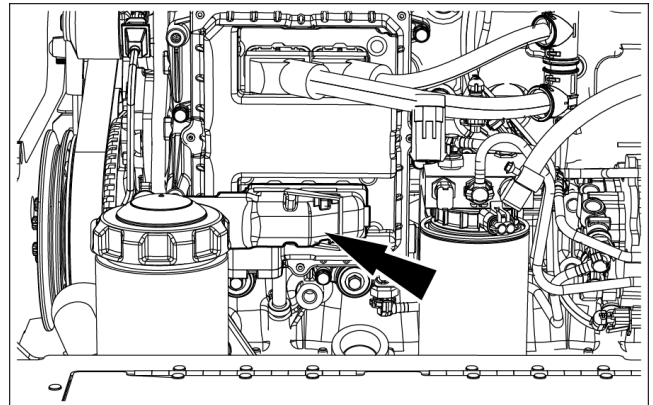

LEIL17WHL0215AB 6

12. Connect the grid heater cable to the grid heater. Refer to marked tag to ensure cable is installed correctly.
13. Connect the wire harness (2) to the primary fuel filter (1). Refer to marked tag to ensure wires are installed correctly.

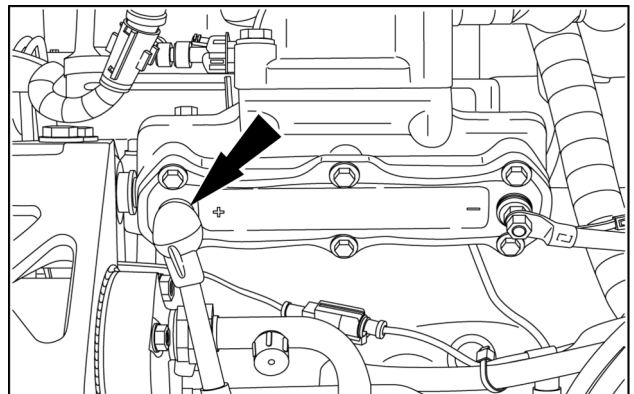

RAPH12WEL1478AA 7

<https://www.ebooklibonline.com>

Hello dear friend!

Thank you very much for reading.

Enter the link into your browser.

The full manual is available for immediate download.

<https://www.ebooklibonline.com>