

**521F**  
**Tier 4B (final)**  
Wheel Loader

**SERVICE MANUAL**

**Part number 47955970**  
1<sup>st</sup> edition English  
February 2016



# Link Product / Engine

---

<b>Product</b>	<b>Market Product</b>	<b>Engine</b>
521F TIER4B Z-BAR	North America	F4HFE413N*B001
521F TIER4B XT	North America	F4HFE413N*B001
521F TIER4B XR	North America	F4HFE413N*B001

# Contents

---

## INTRODUCTION

<b>Engine</b> .....	<b>10</b>
[10.001] Engine and crankcase .....	10.1
[10.202] Air cleaners and lines .....	10.2
[10.500] Selective Catalytic Reduction (SCR) exhaust treatment .....	10.3
[10.400] Engine cooling system .....	10.4
[10.414] Fan and drive .....	10.5
[10.310] Aftercooler.....	10.6
[10.304] Engine lubrication system.....	10.7
<b>Transmission</b> .....	<b>21</b>
[21.113] Powershift transmission .....	21.1
[21.135] Powershift transmission external controls.....	21.2
[21.155] Powershift transmission internal components.....	21.3
<b>Four-Wheel Drive (4WD) system</b> .....	<b>23</b>
[23.314] Drive shaft.....	23.1
<b>Front axle system</b> .....	<b>25</b>
[25.100] Powered front axle .....	25.1
[25.102] Front bevel gear set and differential .....	25.2
[25.108] Final drive hub, steering knuckles, and shafts .....	25.3
[25.310] Final drives .....	25.4
<b>Rear axle system</b> .....	<b>27</b>
[27.100] Powered rear axle.....	27.1
[27.106] Rear bevel gear set and differential .....	27.2
[27.120] Planetary and final drives .....	27.3
[27.124] Final drive hub, steering knuckles, and shafts .....	27.4
<b>Brakes and controls</b> .....	<b>33</b>

**<https://www.ebooklibonline.com>**

Hello dear friend!

Thank you very much for reading.

Enter the link into your browser.

The full manual is available for immediate download.

**<https://www.ebooklibonline.com>**

[33.202] Hydraulic service brakes .....	33.1
[33.110] Parking brake or parking lock .....	33.2
<b>Hydraulic systems.....</b>	<b>35</b>
[35.000] Hydraulic systems.....	35.1
[35.300] Reservoir, cooler, and filters.....	35.2
[35.106] Variable displacement pump .....	35.3
[35.359] Main control valve.....	35.4
[35.357] Pilot system .....	35.5
[35.752] Hydraulic fan drive cooling system.....	35.6
[35.355] Hydraulic hand control .....	35.7
[35.701] Front loader arm hydraulic system .....	35.8
[35.723] Front loader bucket hydraulic system .....	35.9
[35.734] Tool quick coupler hydraulic system .....	35.10
<b>Frames and ballasting .....</b>	<b>39</b>
[39.100] Frame .....	39.1
<b>Steering.....</b>	<b>41</b>
[41.200] Hydraulic control components.....	41.1
[41.216] Cylinders .....	41.2
[41.910] Auxiliary steering .....	41.3
<b>Wheels .....</b>	<b>44</b>
[44.511] Front wheels.....	44.1
[44.520] Rear wheels.....	44.2
<b>Cab climate control .....</b>	<b>50</b>
[50.100] Heating.....	50.1
[50.200] Air conditioning .....	50.2
<b>Electrical systems.....</b>	<b>55</b>
[55.000] Electrical system .....	55.1

[55.100] Harnesses and connectors.....	55.2
[55.015] Engine control system.....	55.3
[55.201] Engine starting system .....	55.4
[55.301] Alternator.....	55.5
[55.302] Battery.....	55.6
[55.202] Cold start aid .....	55.7
[55.011] Fuel tank system .....	55.8
[55.988] Selective Catalytic Reduction (SCR) electrical system .....	55.9
[55.989] Exhaust Gas Recirculation (EGR) electrical system .....	55.10
[55.012] Engine cooling system .....	55.11
[55.024] Transmission control system.....	55.12
[55.519] Cab brake controls .....	55.13
[55.030] Service brake electrical system .....	55.14
[55.031] Parking brake electrical system .....	55.15
[55.512] Cab controls.....	55.16
[55.036] Hydraulic system control .....	55.17
[55.051] Cab Heating, Ventilation, and Air-Conditioning (HVAC) controls.....	55.18
[55.050] Heating, Ventilation, and Air-Conditioning (HVAC) control system.....	55.19
[55.047] Steering control system .....	55.20
[55.524] Cab controls (Lift arm, Boom, Dipper, Bucket).....	55.21
[55.415] Loader arm and bucket control system .....	55.22
[55.518] Wiper and washer system.....	55.23
[55.404] External lighting .....	55.24
[55.405] External lighting switches and relays .....	55.25
[55.514] Cab lighting .....	55.26
[55.510] Cab or platform harnesses and connectors.....	55.27
[55.408] Warning indicators, alarms, and instruments .....	55.28
[55.DTC] FAULT CODES.....	55.29
<b>Front loader and bucket.....</b>	<b>82</b>

[82.100] Arm.....	82.1
[82.300] Bucket.....	82.2
<b>Platform, cab, bodywork, and decals .....</b>	<b>90</b>
[90.150] Cab.....	90.1
[90.156] Cab glazing .....	90.2
[90.105] Machine shields and guards .....	90.3



## INTRODUCTION

---

## **Foreword - Important notice regarding equipment servicing**

All repair and maintenance work listed in this manual must be carried out only by qualified dealership personnel, strictly complying with the instructions given, and using, whenever possible, the special tools.

Anyone who performs repair and maintenance operations without complying with the procedures provided herein shall be responsible for any subsequent damages.

The manufacturer and all the organizations of its distribution chain, including - without limitation - national, regional, or local dealers, reject any responsibility for damages caused by parts and/or components not approved by the manufacturer, including those used for the servicing or repair of the product manufactured or marketed by the manufacturer. In any case, no warranty is given or attributed on the product manufactured or marketed by the manufacturer in case of damages caused by parts and/or components not approved by the manufacturer.

The manufacturer reserves the right to make improvements in design and changes in specifications at any time without notice and without incurring any obligation to install them on units previously sold. Specifications, descriptions, and illustrative material herein are as accurate as known at time of publication but are subject to change without notice.

In case of questions, refer to your CASE CONSTRUCTION Sales and Service Networks.

## Safety rules

### Personal safety



This is the safety alert symbol. It is used to alert you to potential personal injury hazards. Obey all safety messages that follow this symbol to avoid possible death or injury.

Throughout this manual you will find the signal words DANGER, WARNING, and CAUTION followed by special instructions. These precautions are intended for the personal safety of you and those working with you.

Read and understand all the safety messages in this manual before you operate or service the machine.

 DANGER indicates a hazardous situation that, if not avoided, will result in death or serious injury.

 WARNING indicates a hazardous situation that, if not avoided, could result in death or serious injury.

 CAUTION indicates a hazardous situation that, if not avoided, could result in minor or moderate injury.

**FAILURE TO FOLLOW DANGER, WARNING, AND CAUTION MESSAGES COULD RESULT IN DEATH OR SERIOUS INJURY.**

### Machine safety

**NOTICE:** Notice indicates a situation that, if not avoided, could result in machine or property damage.

Throughout this manual you will find the signal word Notice followed by special instructions to prevent machine or property damage. The word Notice is used to address practices not related to personal safety.

### Information

**NOTE:** Note indicates additional information that clarifies steps, procedures, or other information in this manual.

Throughout this manual you will find the word Note followed by additional information about a step, procedure, or other information in the manual. The word Note is not intended to address personal safety or property damage.

## Personal safety

Carefully read this Manual before proceeding with maintenance, repairs, refuelling or other machine operations.

Repairs have to be carried out only by authorized and instructed staff; specific precautions have to be taken when grinding, welding or when using mallets or heavy hammers.

Non-authorized persons are not allowed to repair or carry out maintenance on this machine. Do not carry out any work on the equipment without prior authorization.

Ask your employer about the safety instructions in force and safety equipment.

Nobody should be allowed in the cab during machine maintenance unless he is a qualified operator helping with the maintenance work.

If it is necessary to move the equipment to carry out repairs or maintenance, do not lift or lower the equipment from any other position than the operator's seat.

Never carry out any operation on the machine when the engine is running, except when specifically indicated.

Stop the engine and ensure that all pressure is relieved from hydraulic circuits before removing caps, covers, valves, etc.

All repair and maintenance operations should be carried out with the greatest care and attention.

Service stairs and platforms used in a workshop or in the field should be built in compliance with the safety rules in force.

Any functional disorders, especially those affecting the safety of the machine, should therefore be rectified immediately.

### **⚠ DANGER**

**Unexpected movement!**  
**Make sure parking brake is applied. Secure machine with wheel chocks.**  
**Failure to comply will result in death or serious injury.**

D0013A

Before performing any work on the machine, attach a maintenance in progress tag. This tag can be applied on the left-hand control lever, safety lever or cab door.

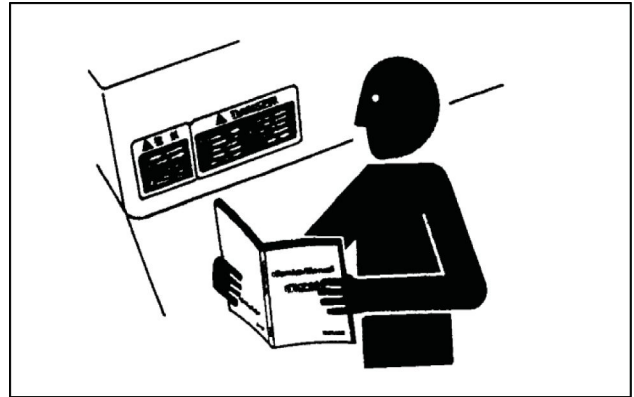

TULI12WEX2004AA 1

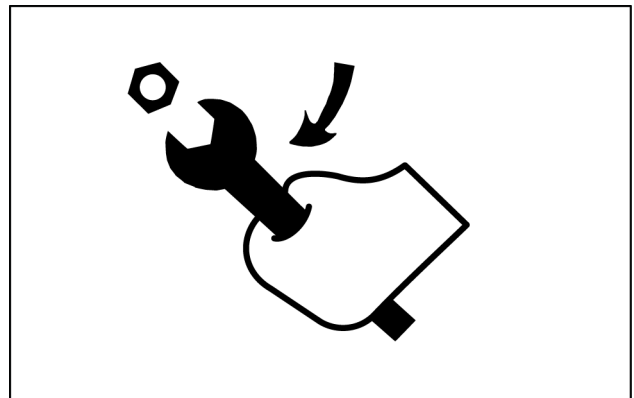

TULI12WEX2005AA 2

## Product identification

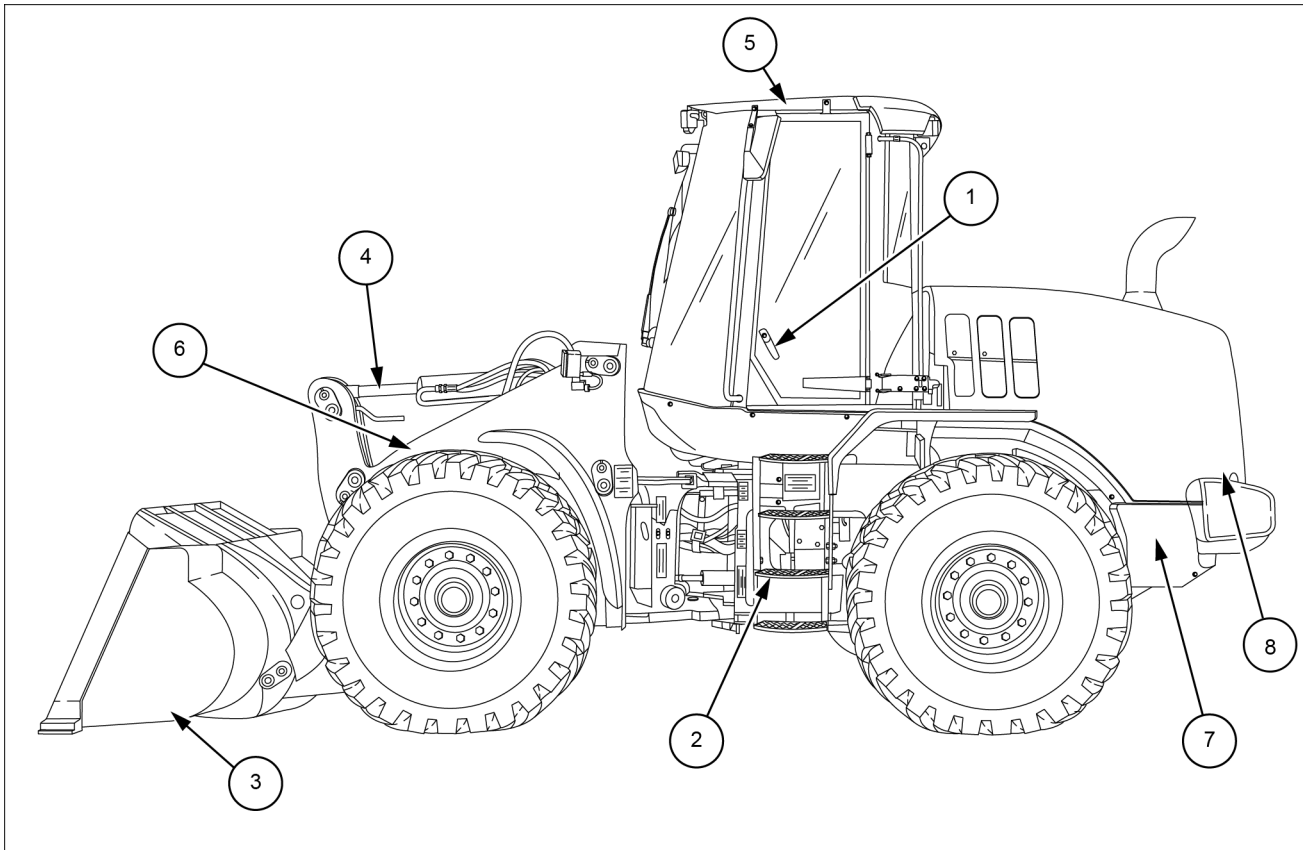

LEIL15WHL0182FB 1

1. Cab door and hand holds
2. Steps
3. Bucket (Z-bar version)
4. Bucket cylinder

5. Roll Over Protection System (ROPS) cab
6. Loader lift arms
7. Battery compartment
8. Master disconnect switch

## INTRODUCTION

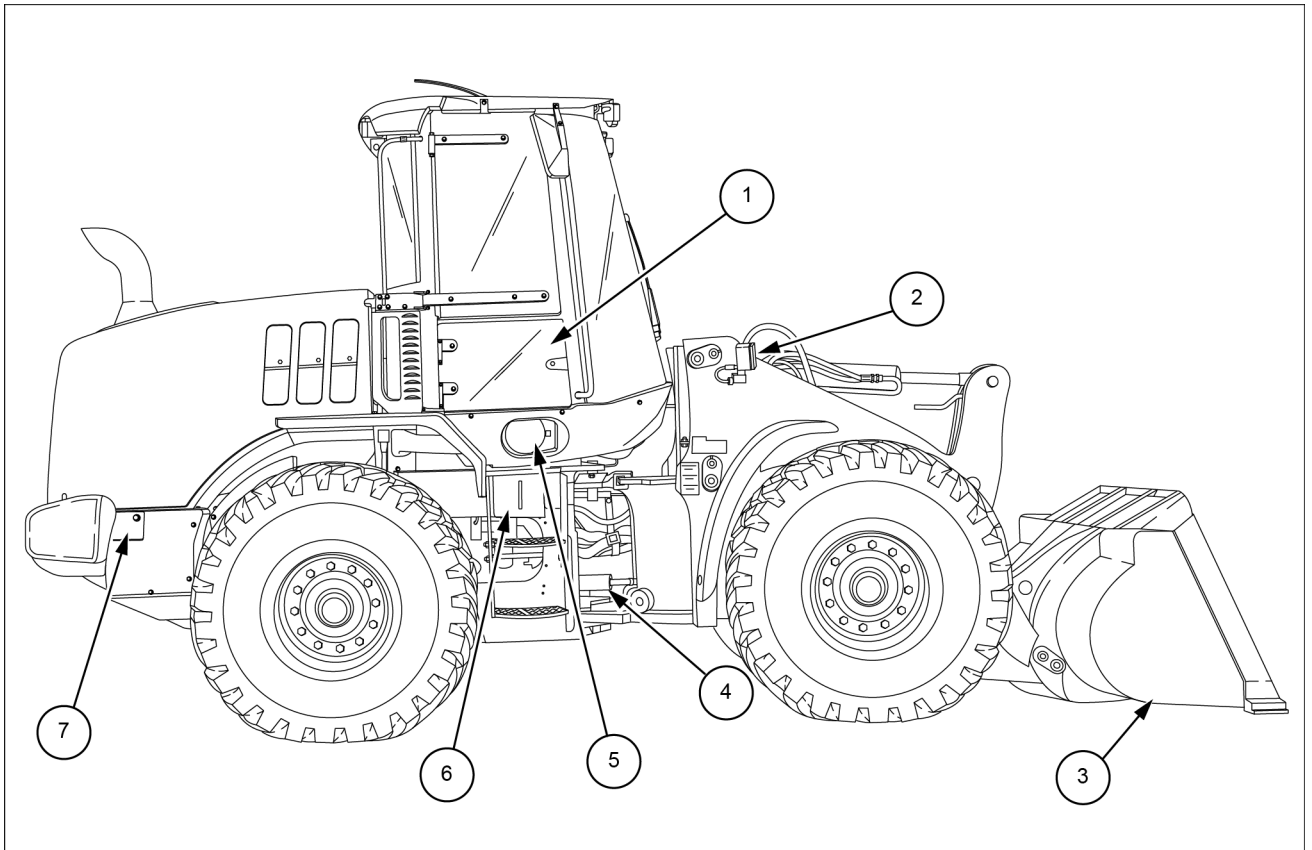

LEIL15WHL0183FB 2

- |                           |                                 |
|---------------------------|---------------------------------|
| 1. Fuse access door       | 5. Windshield washer reservoir  |
| 2. Driving lights         | 6. Cab air filter access        |
| 3. Bucket (Z-bar version) | 7. <b>DEF/AdBLUE®</b> fill tank |
| 4. Drive shaft            |                                 |



# **SERVICE MANUAL**

**Engine**

**521F**

## Engine - General specification

Engine with 4 Speed Transmission	
A. Low idle	<b>1020 - 1080 RPM</b>
Alternate low idle	<b>870 - 930 RPM</b>
Alternate Accelerated Idle	<b>1270 - 1330 RPM</b>
B. Maximum No Load RPM	<b>2074 - 2244 RPM</b>
C. Converter Stall	<b>1950 - 2030 RPM</b>
D. Hydraulic Stall	<b>1900 - 2100 RPM</b>
E. Converter and Hydraulic Stall	<b>1400 - 1600 RPM</b>
Temperature of the torque converter oil	<b>82 - 104 °C (180 - 219 °F)</b>
Temperature of the hydraulic oil	<b>54 - 57 °C (129 - 135 °F)</b>

**NOTE:** hydraulic stall and converter and hydraulic stall RPM values are read with the lift arms rised, the bucket held in rolled back position, and the engine at Wide Open Throttle (WOT) in maximum power mode with the transmission in manual mode and in third gear.

## Engine - Remove

**NOTE:** emissions sensors mounted in the exhaust stream are sensitive to extreme vibrations. Use of tools that generate extreme vibrations, such as impact wrenches and hammers, will result in damage to emission sensors. Avoid using these tools during any service procedure in close proximity of emission sensors. If the use of these tools cannot be avoided, remove the sensors using extreme caution prior to performing any service procedure.

1. Park the machine on a level surface and lower the bucket to the ground. Put the articulation lock in the LOCKED position.

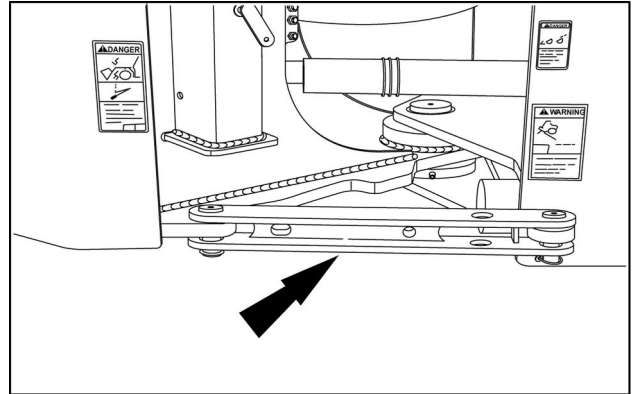

RAPH12WEL1412AA 1

2. Turn the engine OFF. Actuate the brake pedal several times to discharge the brake accumulators.

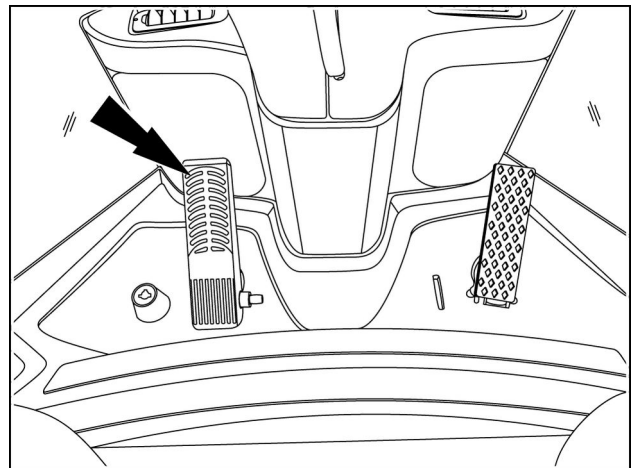

RCPH10WHL435AAH 2

3. Turn the key switch to the ON position. Move the loader control lever back and forth minimally 30 times to release pressure from the hydraulic circuit. Turn the key switch to the OFF position.

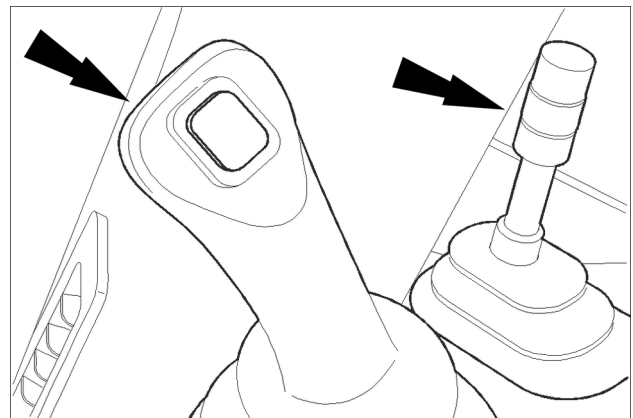

RCPH10WHL119BAL 3

4. Slowly loosen the hydraulic reservoir filler cap to release air pressure in the hydraulic reservoir.

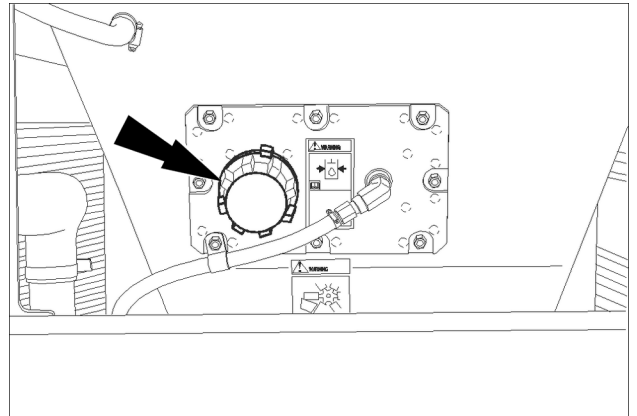

RCPH10WHL099BAL 4

5. Raise the engine hood using the handle hood under the rear grill.

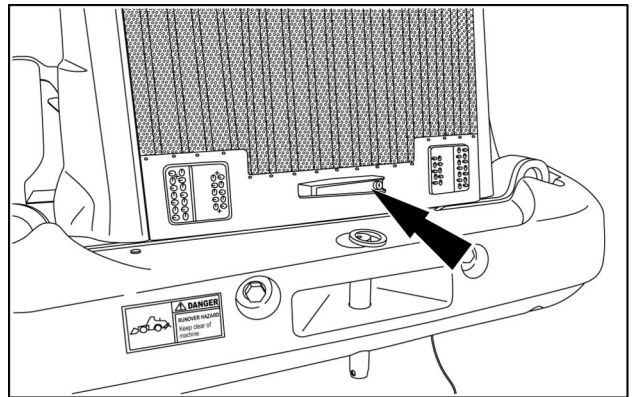

RAPH12WEL1493AA 5

6. Remove the retaining bolts of the inner fender panels.  
**NOTE:** right-hand side of the machine is shown. The operation is similar for the left-hand side.

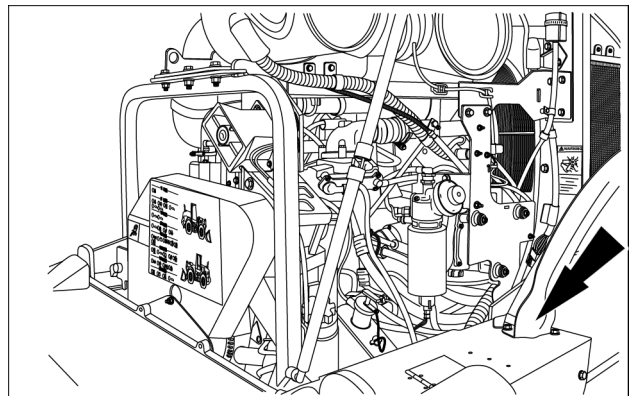

LEIL15WHL0282AA 6

7. Locate the master disconnect switch under the engine hood, on the left-hand side of the machine. Turn the master disconnect switch to the OFF position.

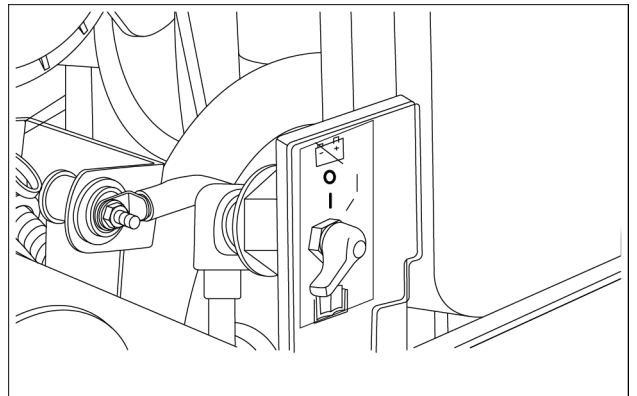

LEIL15WHL0327AA 7

8. Remove the two battery covers. Disconnect the batteries from the machine.

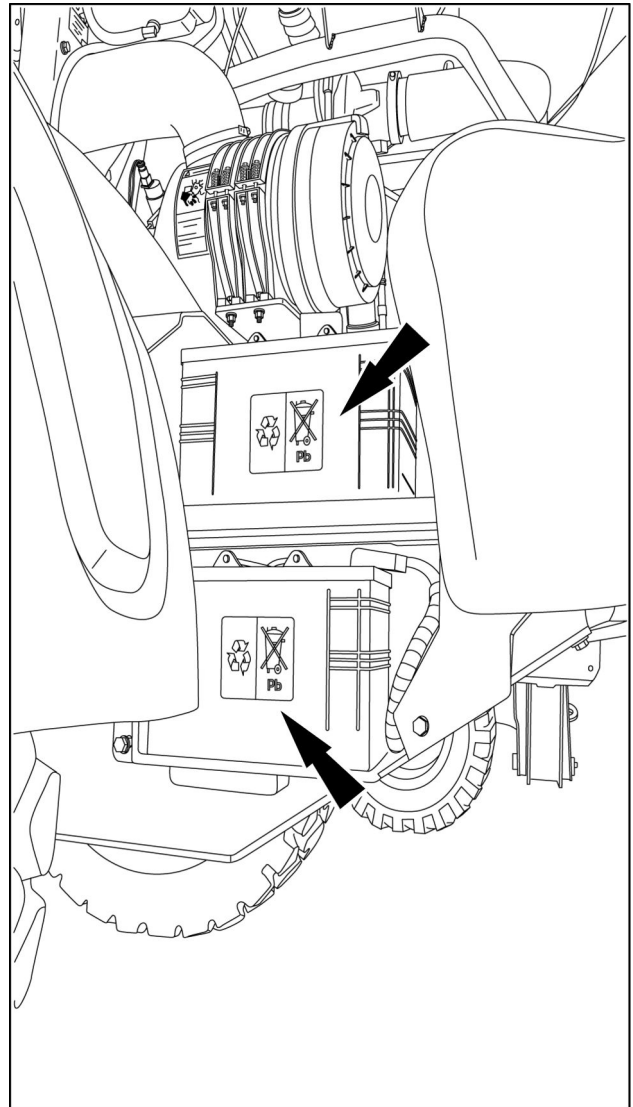

RAPH12WEL1495CA 8

9. Loosen the screw (1) and open the access cover (2) under the battery.

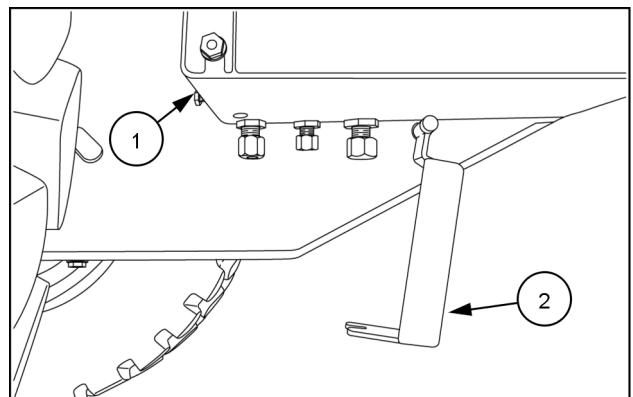

RAPH12WEL1494AA 9

10. Place a suitable container below the radiator drain. Remove the drain plug (1) and radiator cap to drain the engine coolant into the container. then reinstall the radiator cap after the coolant has drained.

**NOTE:** see machine specifications for cooling system volum.

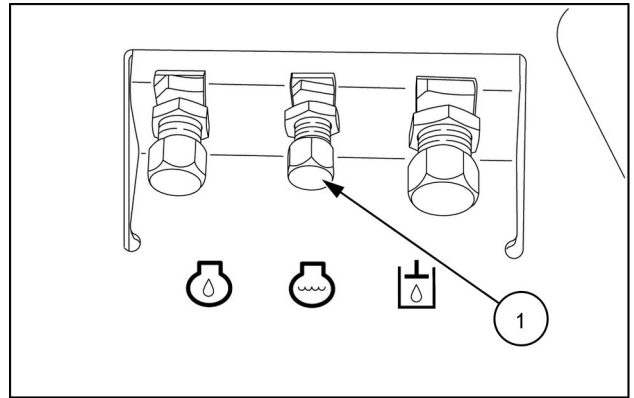

11. Place a suitable container below the engine oil drain. Remove the engine oil cap (2) to drain the engine oil into the container. Then reinstall the engine oil cap after the engine oil has drained.

**NOTE:** see machine specifications for cooling system volume.

**NOTE:** after draining the engine oil, disconnect the drain hose from the frame to aid in removal of engine.

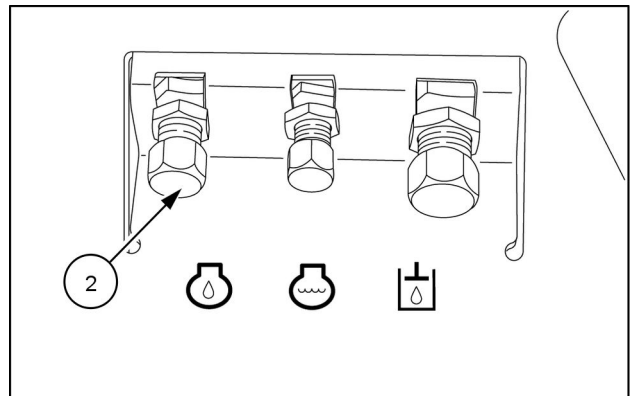

12. Double up a nylon lifting strap and slide the strap through the exhaust stack (1), located on the hood.

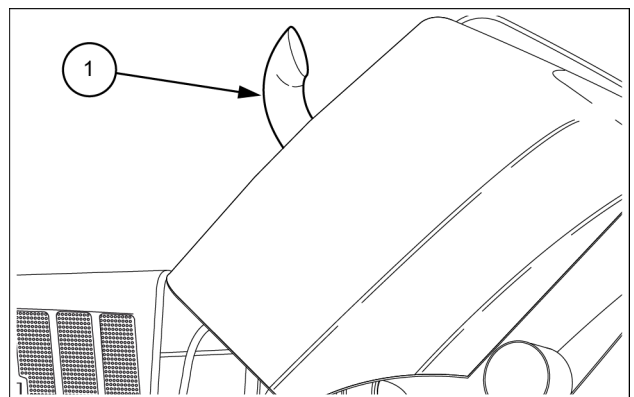

13. Place a solid steel bar through the nylon strap. Raise the hood and release the tension on the lifting motor.

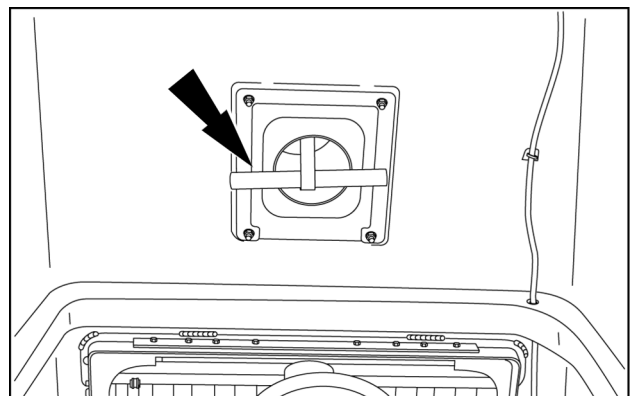

14. Remove the right-hand gas strut from the hood.  
Remove the left-hand gas strut from the hood.

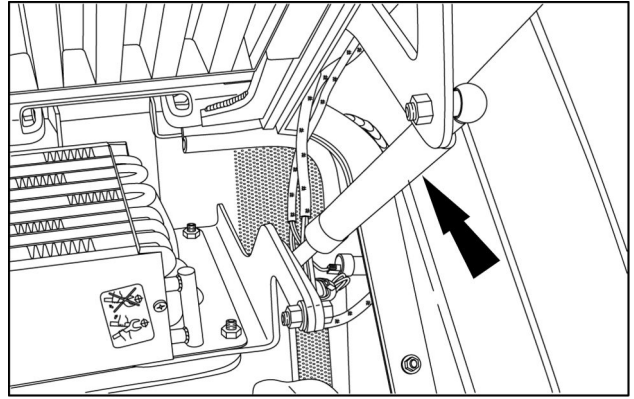

RAPH12WEL1489AA 14

15. Remove the spring gas to separate the engine hood from the rear chassis.

**NOTE:** for clarify, the engine hood is in NO show.

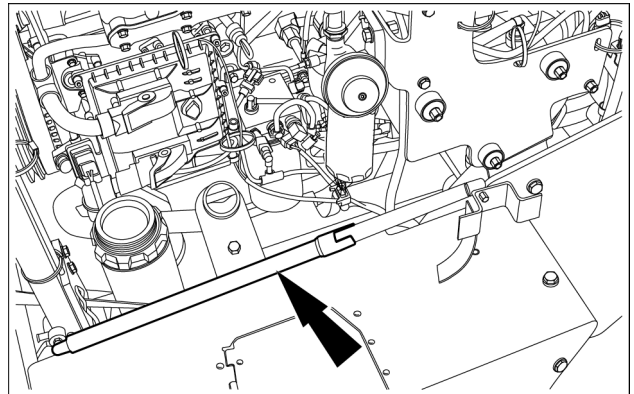

LEIL15WHL0141AB 15

16. Disconnect the hood wiring harness connector from the rear chassis wiring harness connector. Identify and tag the connectors to aid in reassembly.

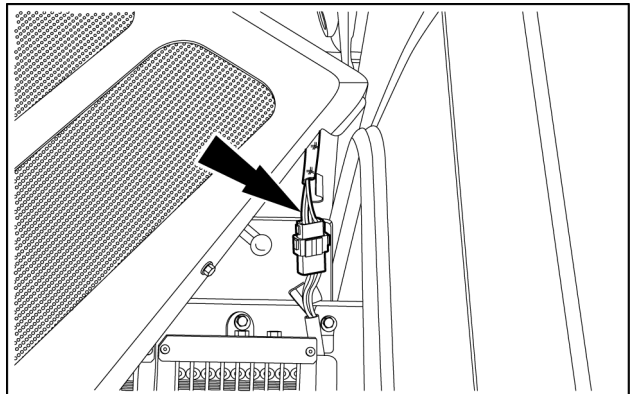

LEIL15WHL0142AB 16

17. Tag and disconnect the backup alarm connector (1).  
Remove the two straps cable tie (2).

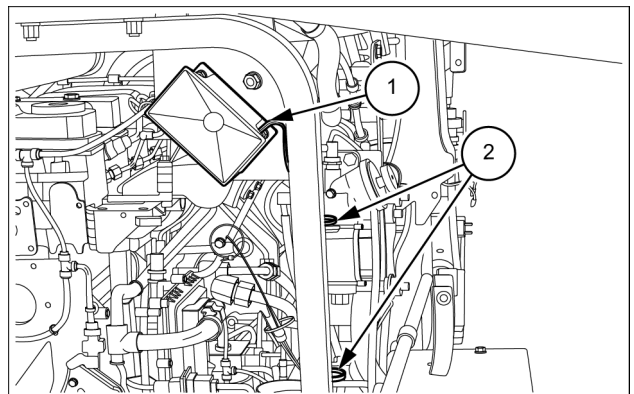

LEIL15WHL0143AB 17

18. With the assistance of another technician, balance the engine hood and remove the hood hinge mounting bolts (1) near the cab (2) from the cooler frame. Repeat the procedure for the other side.

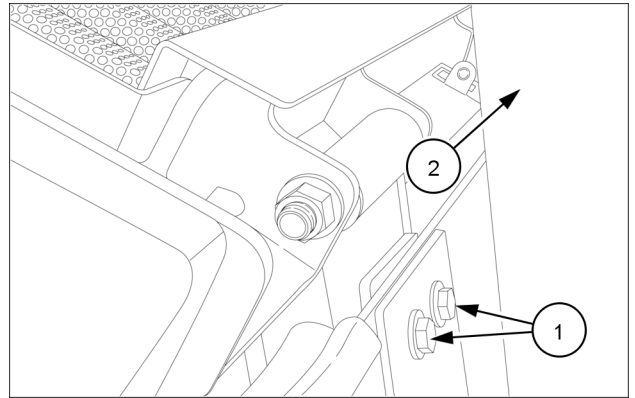

RAPH12WEL1461AA 18

19. Carefully raise and remove the engine hood from the machine. Lower the engine hood onto a suitable platform. Disconnect the lifting equipment from the exhaust stack (1).

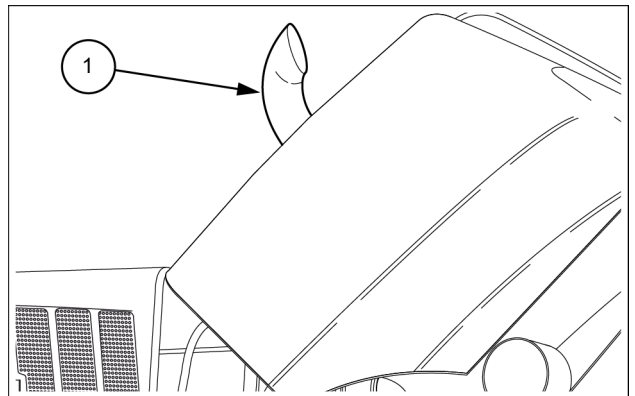

LEIL14WHL0400AB 19

20. Loosen the two bolts (2) and the related washers to remove the bracket (1) of the relay decal.

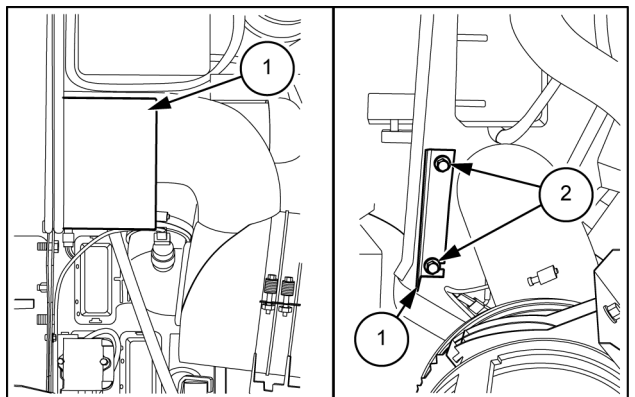

LEIL15WHL0195AB 20

21. Tag and disconnect the engine wiring harness connector from the air filter sensor (1). Loosen the clamp (2) on the air intake hose (3) and disconnect the hose.

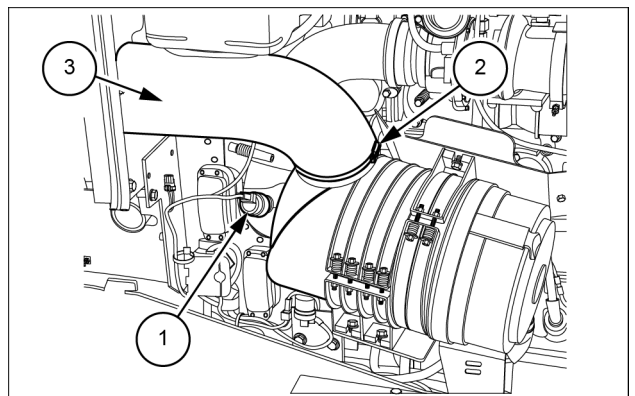

LEIL15WHL0196AB 21

22. Tag and disconnect the engine wiring harness connector from the air inlet humidity sensor (1).

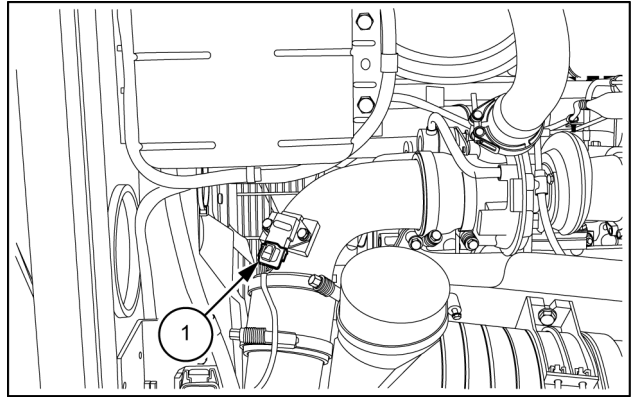

LEIL15WHL0197AB 22

23. Loosen the clamps (2) on the turbocharger.  
24. Loosen the clamps (3) on the air filter housing.  
25. Loosen the clamp (4) on the crankcase vent hose (5).  
26. Remove the intake air hose (1). Cover the turbocharger inlet to prevent debris entry.

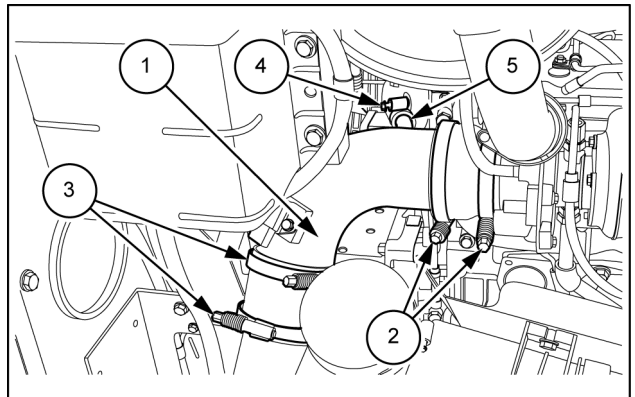

LEIL15WHL0198AB 23

27. Loosen the bolt to separate the P-clamp (of the alternate hose) on the engine side of the head shield.

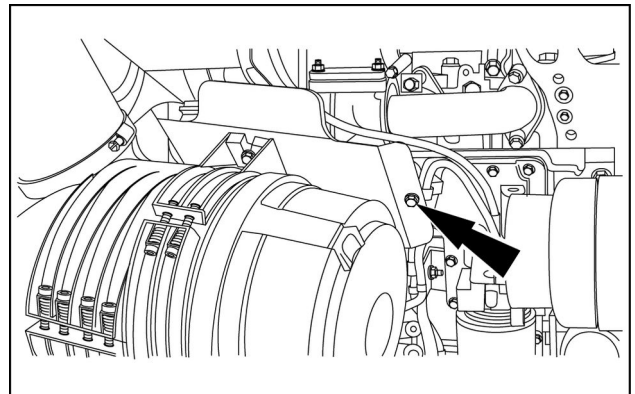

LEIL15WHL0148AA 24

28. Remove the two securing bolts (3), the four washers (4), and two nuts (5). Remove the bracket (2) with the air filter (1) as an assembly.

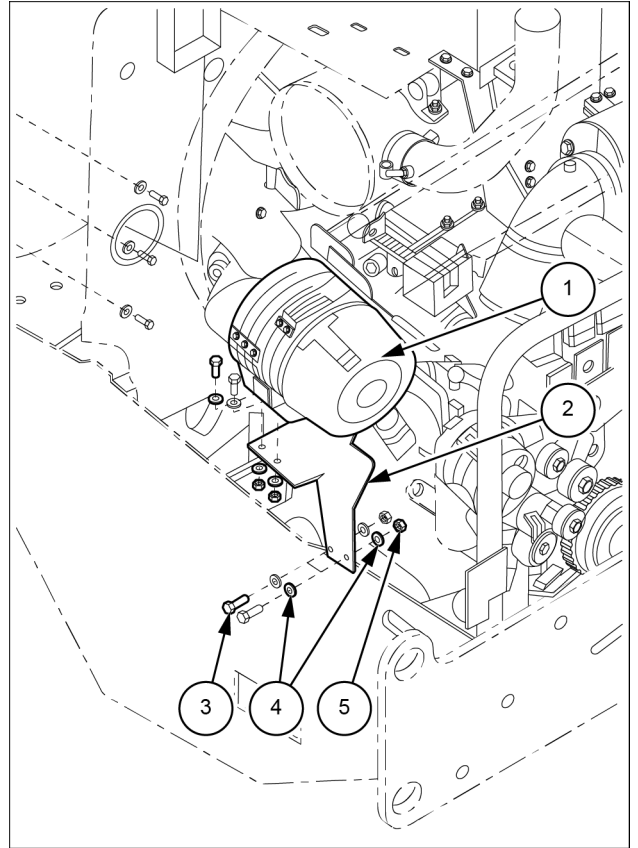

LEIL15WHL0171BB 25

29. Remove the four mounting bolts and the four washers from the belt cover. Remove the cover.

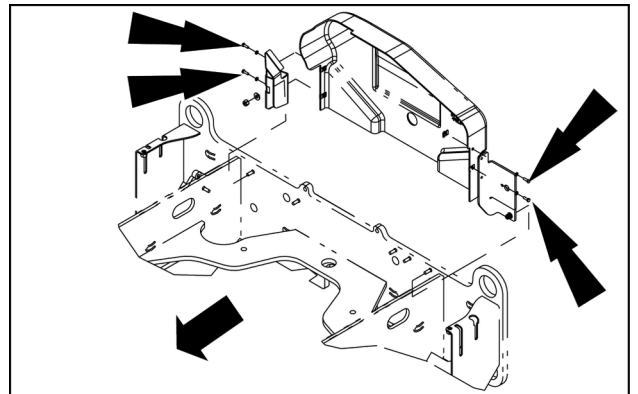

LEIL15WHL0204AA 26

30. After removing the belt cover, remove the cover mounting bracket from the left rear side of machine frame

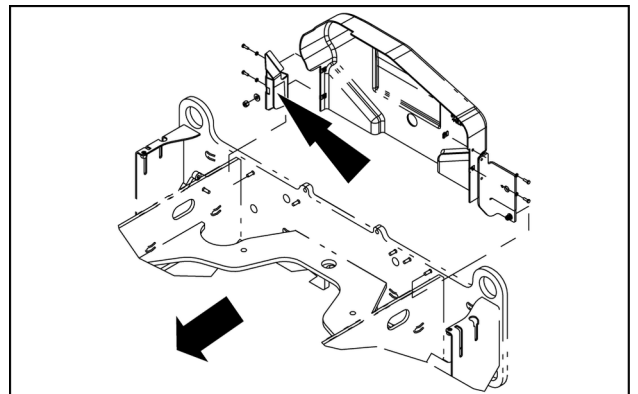

LEIL15WHL0204AA 27

31. Remove the drive belt from the engine.

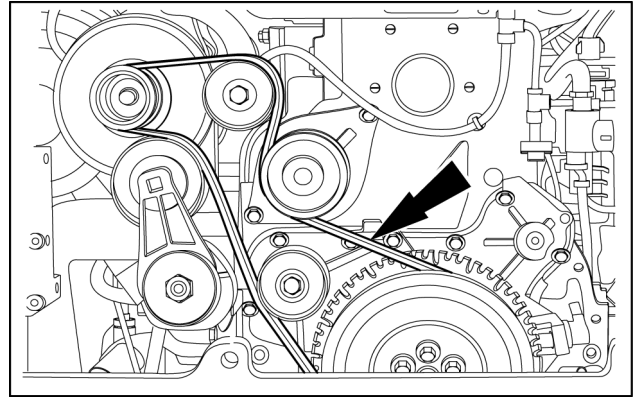

LEIL15WHL0192AB 28

32. If machine is equipped with the air conditioning system, identify, tag, and disconnect the engine wiring harness connectors from the air compressor clutch connector (1). Disconnect the pressure switch (2). Recovery the refrigerant, as indicated in **Air conditioning - Service instruction (50.200)**. Disconnect the low-pressure line (3) from the suction port and the high-pressure line (4) from the discharge port, located on the compressor. Immediately install protective caps on the open ports and lines.

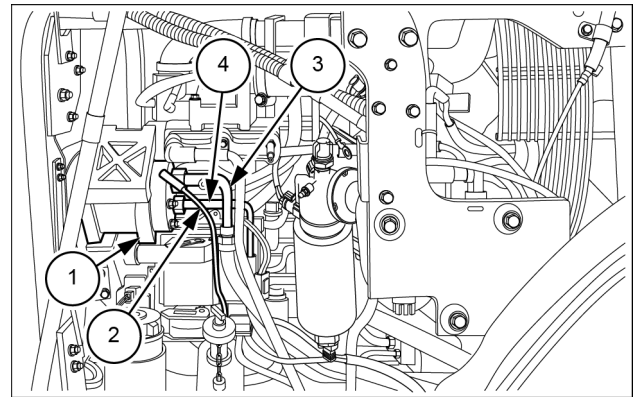

LEIL15WHL0199AB 29

33. Remove the belt (5). Remove the three mounting bolts (6). Remove the bolt (7) and carefully remove the compressor (1) with the support bracket.

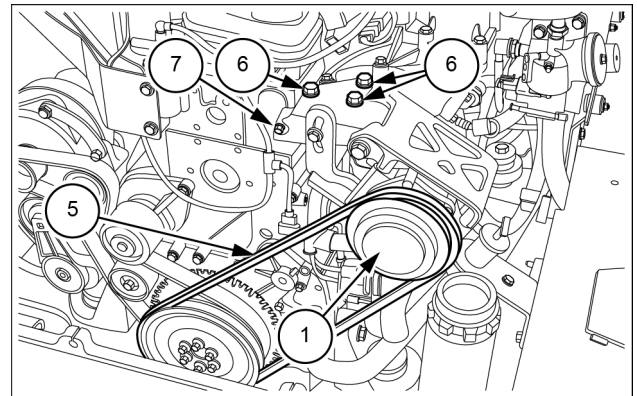

LEIL15WHL0200AB 30

34. Loosen the clamp. Remove and discard the O-ring and the air intake tube of the turbocharger.

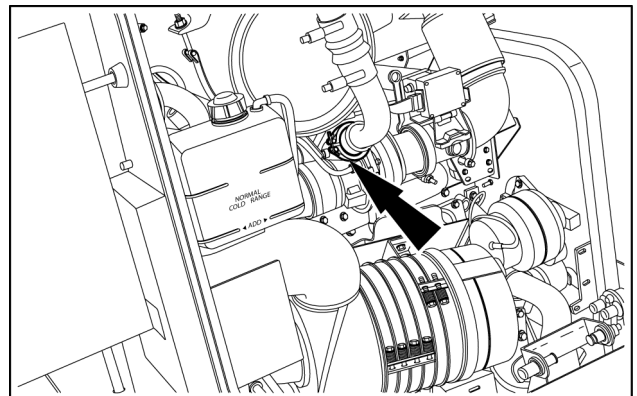

LEIL15WHL0145AB 31

35. Loosen the clamp of the hose of the after cooler inlet and remove the hose.

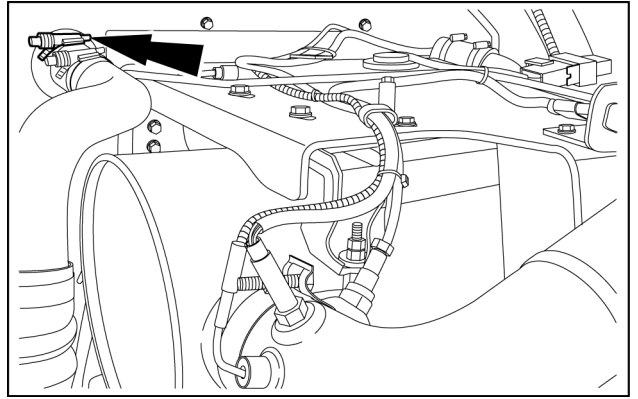

LEIL15WHL0263AB 32

36. Remove the clamp (2) and the clamp (3). Separate the clamp (4) from the bracket of the coolant overflow tank. Loosen the bolts (1) to remove the coolant tank.

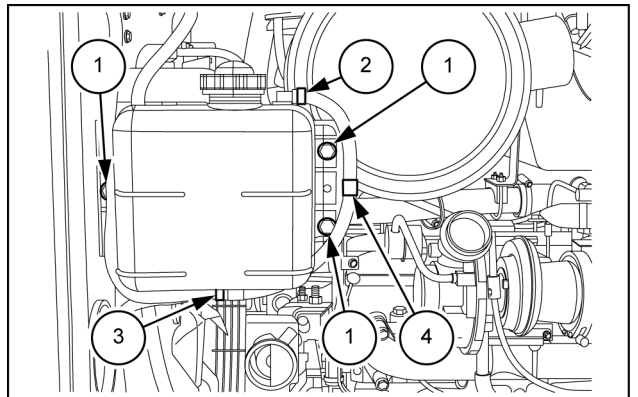

LEIL15WHL0264AB 33

37. Remove the bolts and the washers (2) to separate the bracket (1) of the overflow tank from the rear plate of the cooling system frame.

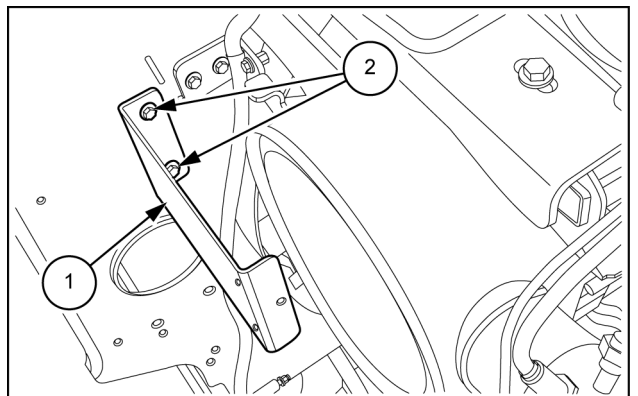

LEIL15WHL0265AB 34

38. Loosen the bolts (1) and remove the two clamps to separate the SCR sensor wiring harness from the rear chassis.

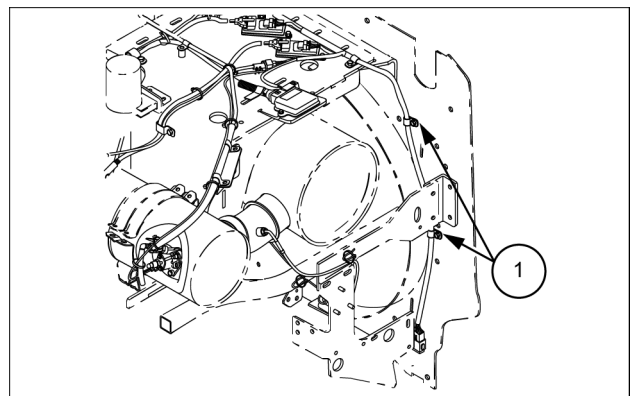

LEIL15WHL0272AB 35

39. Tag and disconnect the SCR sensor connector from the rear chassis harness connector.

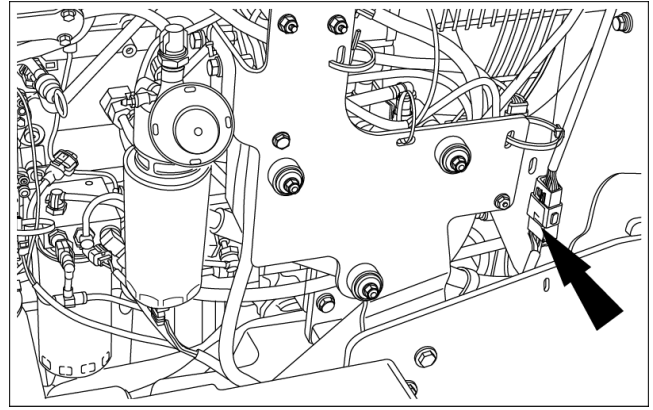

LEIL15WHL0227AB 36

40. Loosen the hexagonal nut of the temperature sensor (1). Disconnect the temperature sensor (1) on the exhaust pipe (DOC to SCR).
41. Tag and disconnect the wire harness (3) of the rear chassis wiring harness of the temperature sensor (1). Cut the straps (2) that hold the sensor lead.

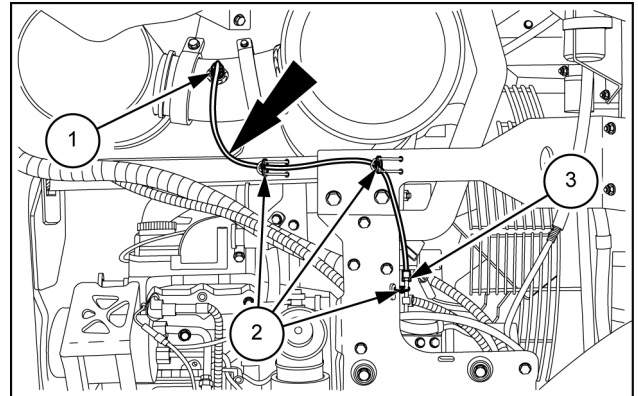

LEIL15WHL0266AB 37

42. Remove the bolts, the washers, and the nuts (3) to separate the bracket (2) of the tube radiator from the muffler support (1).

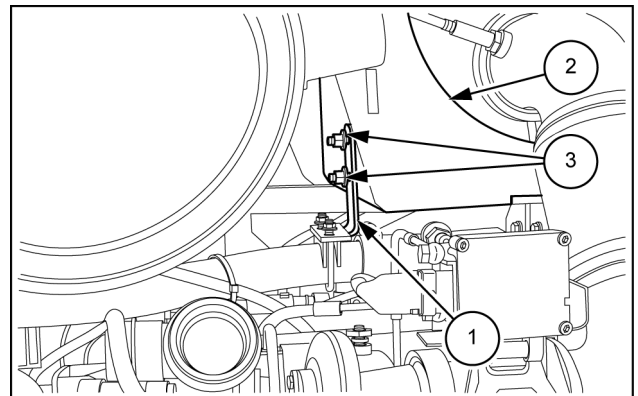

LEIL15WHL0267AB 38

43. Remove the two bolts (1), the four washers (2), and the two nuts (3) to separate the clamps (4) and (6) from the bracket (8).  
Remove the clamp (4) from the DEF bundle (5). Remove the clamp (6) from the hose coolant assembly (7).

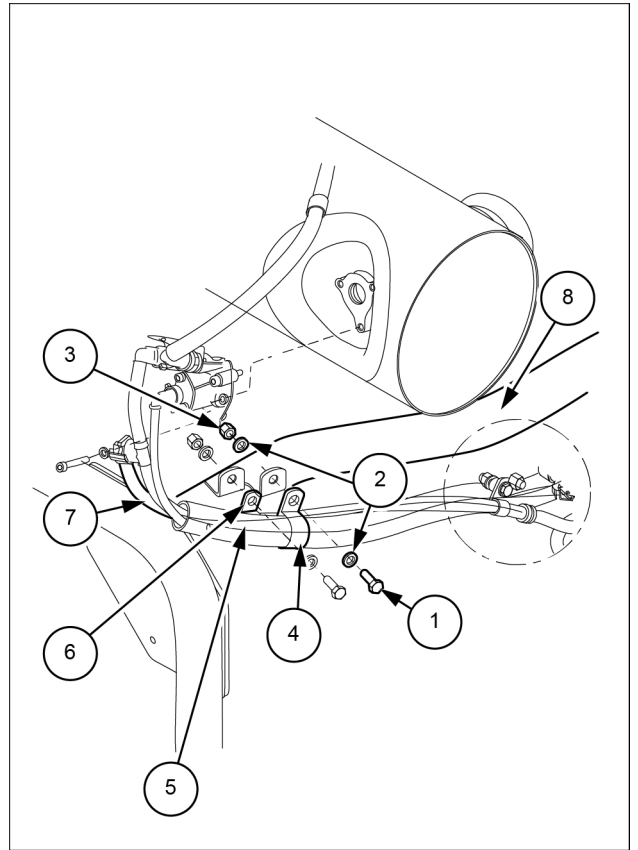

LEIL15WHL0193BB 39

44. Remove the two bolts (4), the washers (5), the spacer (10), and the nut (6) to separate the clamp (3) from the bracket (11). Remove the clamp (3) from the hose coolant assembly (1).
45. Remove the two bolts (8), the washers (9), and the nut (6) to separate the clamp (7) from the bracket (11). Remove the clamp (7) from the DEF bundle (2).

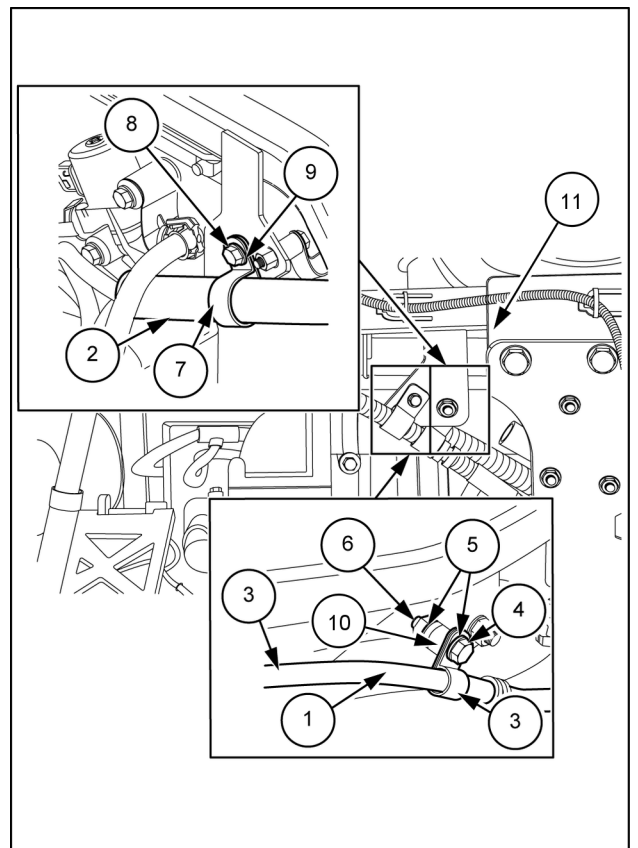

LEIL15WHL0261BB 40

46. Drain the engine coolant.  
Disconnect the hoses (1) from the Dosing Module (2).

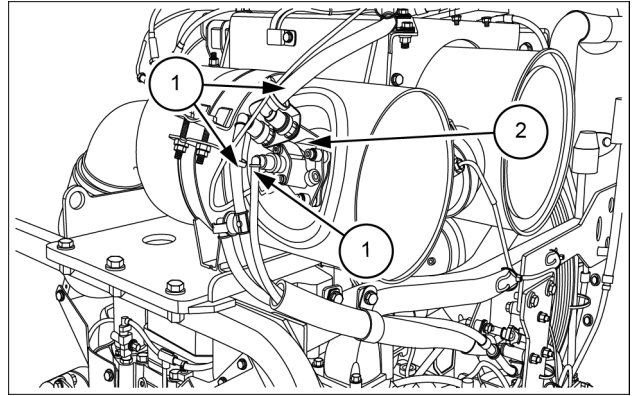

LEIL15WHL0323AB 41

47. Disconnect the electrical connector (3) from the Dosing Module (2).

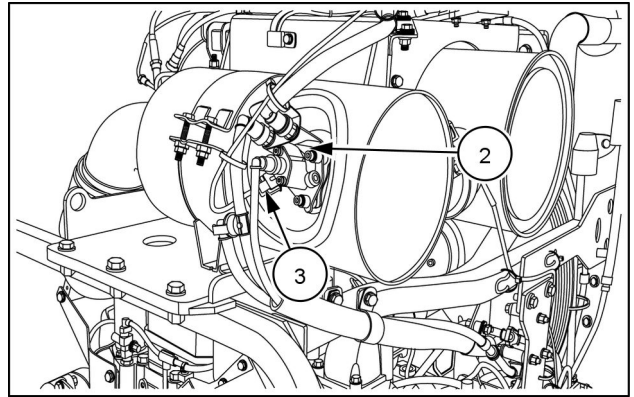

LEIL15WHL0176AA 42

48. Loosen the bolt to remove the P-clamps (1). Disconnect the return coolant hose (2) and remove it from the machine.

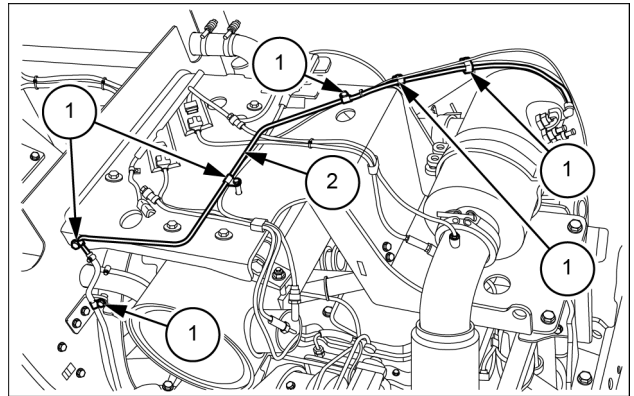

LEIL15WHL0270AB 43

49. Loosen the bolt (1) and remove the P-clamp (3) from the supply module support (4). Remove the P-clamp (2). Tag and disconnect the hose (5) from the DEF/ADBLUE® tank vent filter.

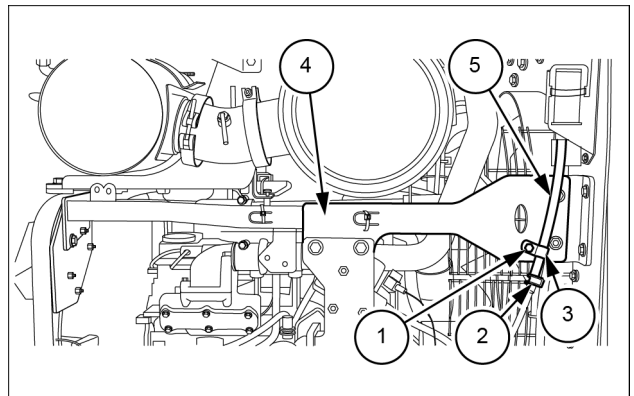

LEIL15WHL0269AB 44

50. Remove the bolts (2) to remove the DEF/AdBLUE® tank vent filter (1) from the rear plate of the cooling system frame.

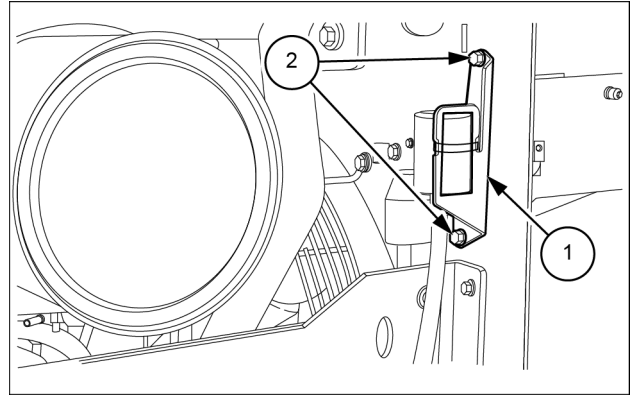

LEIL15WHL0268AB 45

51. Remove the bolts (2) and washers to remove the bracket (1) from the engine.

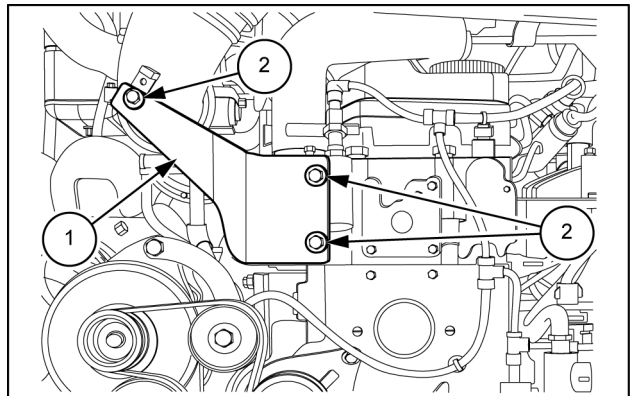

LEIL15WHL0191AB 46

52. Loosen the clamp (1) to separate the exhaust flap from the inlet DOC pipe.

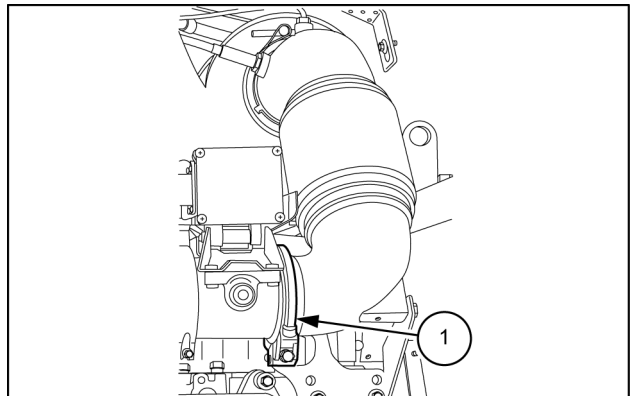

LEIL15WHL0172AB 47

53. Attach a suitable lifting straps to support the muffler support (1) with the Diesel Oxidation Catalyst (DOC) (6) and the Selective Catalytic Reduction muffler (SCR) (7).
54. Remove the bolts (4) and (5) with their related washers to separate the muffler support (1) from the support structures (2) and (3).
55. Remove the muffler support (1), the SCR and the SCR sensor harness as an assembly.

**NOTE:** do not damage the muffler support during removal.

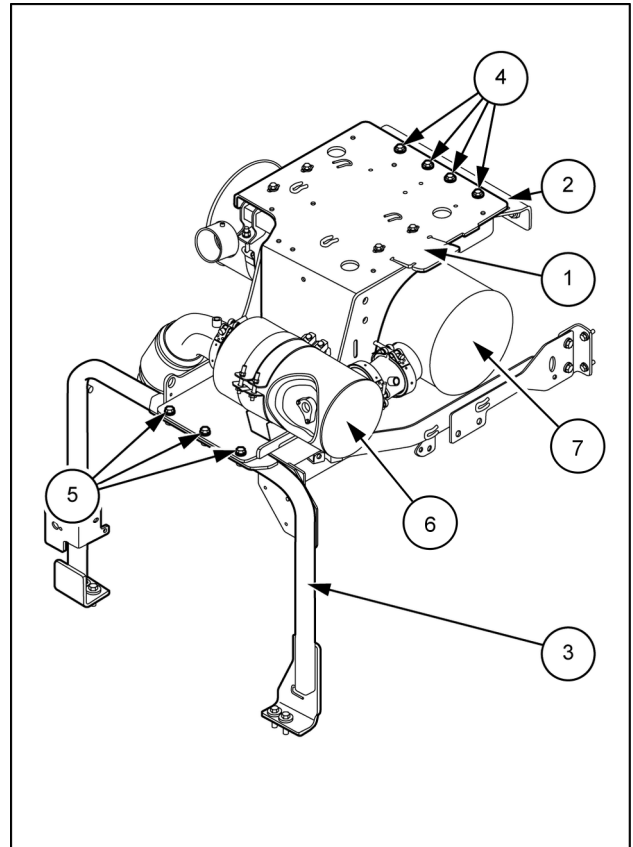

LEIL15WHL0178BB 48

56. Tag and disconnect the DEF/AdBLUE® supply and return lines (1) from the supply module. Tag and disconnect the coolant water supply and return lines (2) from the supply module. Tag and disconnect the wiring harness (3) from the supply module.

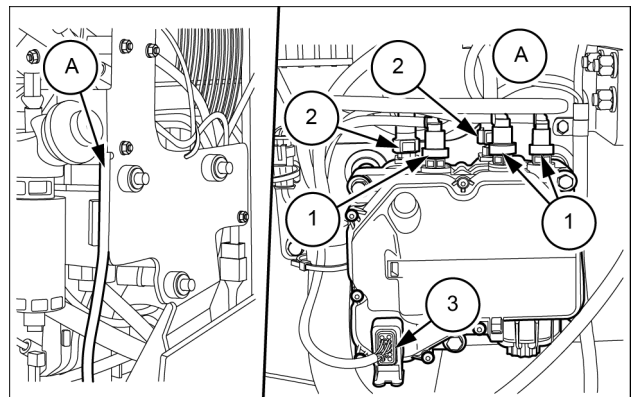

LEIL15WHL0271AB 49

57. Push inward on the fitting retaining clip and disconnect the coolant outlet (2), the coolant inlet (1) and by-pass (3) lines from the heater control valve. Tag and disconnect the machine wiring harness (4) from the heater control valve.

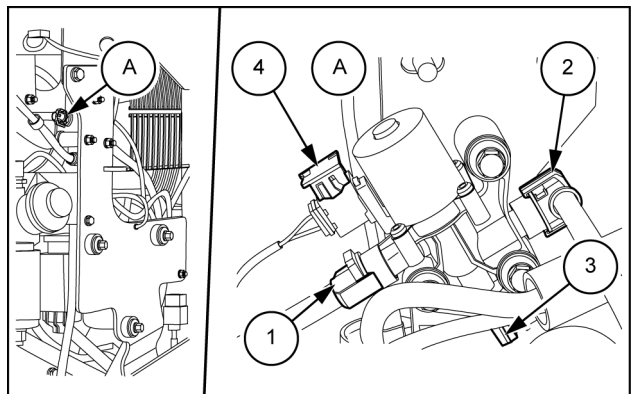

LEIL15WHL0273AB 50

58. Tag and disconnect the fuel filter heater wire (1) and the water sensor (2). Drain the fuel filter and disconnect the inlet fuel line (3) and outlet fuel line (4) from the fuel filter head. Plug the lines and cap the fittings.

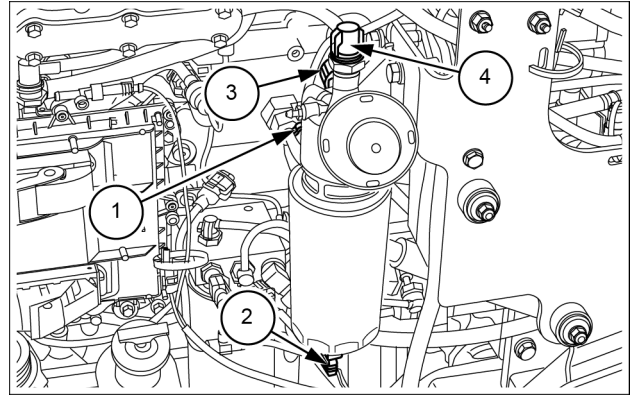

LEIL15WHL0274AB 51

59. Remove the fuel line from the top of the ECU (Engine Control Unit). Plug the line and cap the fitting.

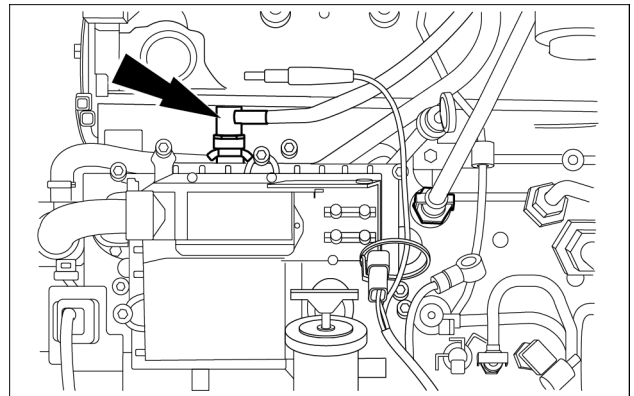

LEIL15WHL0306AB 52

60. Remove the two bolts (1), the washers, and the nuts to separate the bracket (2) of the supply module from the support (3). Remove the two bolts (4), the washers, and the nuts to separate the bracket (2) of the supply module from the rear chassis. Remove the bracket (2) of the supply module, with the supply module, the DEF/ADBLUE® Heater Control valve and the fuel pre-filter as an assembly.

**NOTE:** pay attention to supply module and heater valve.

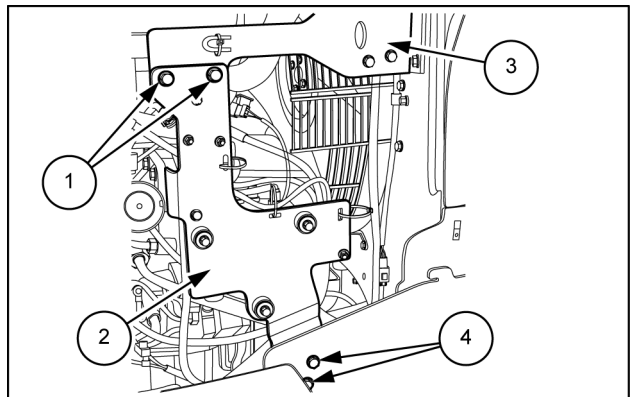

LEIL15WHL0275AB 53

61. Remove the six bolts (1) and the six washer (2). Remove the DEF/ADBLUE® storage tank cover (3) located on the right-hand side of the machine.

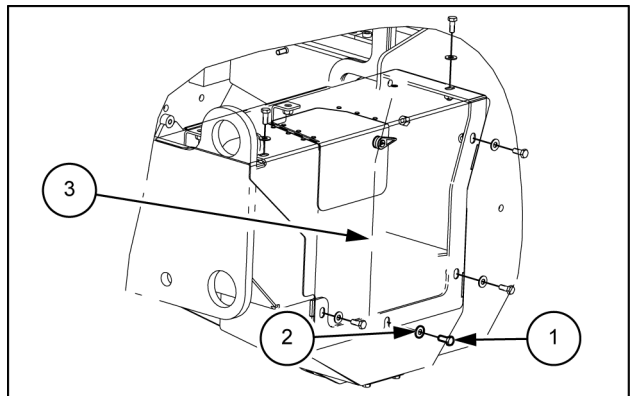

LEIL15WHL0303AB 54

62. Tag and disconnect the wire harness and **DEF/ADBLUE®** supply and return lines from the **DEF/ADBLUE®** storage tank. Cap the supply lines.

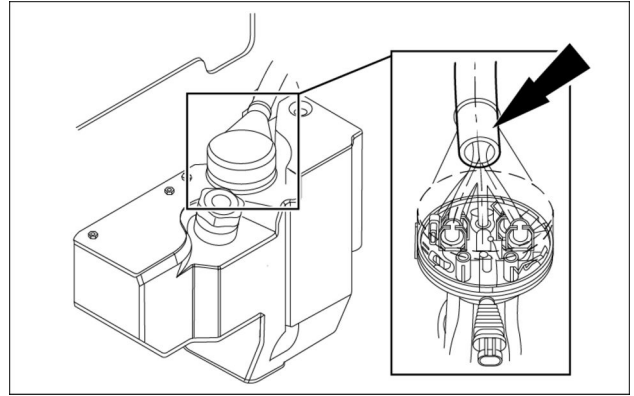

LEIL15WHL0304AA 55

63. Remove the bolts (1), the washers, and the nuts to remove the supply module support (2).

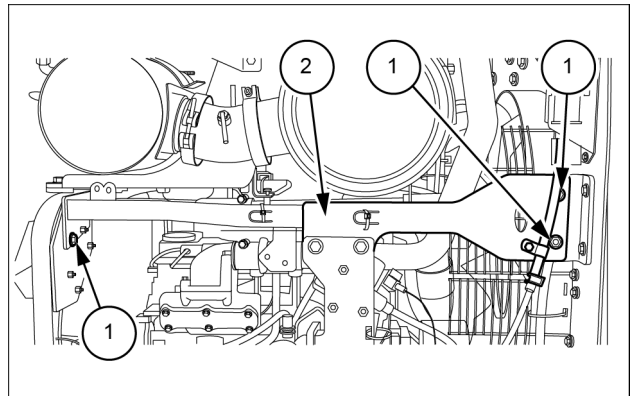

LEIL15WHL0276AB 56

64. Tag and disconnect the cables from the master disconnect switch.

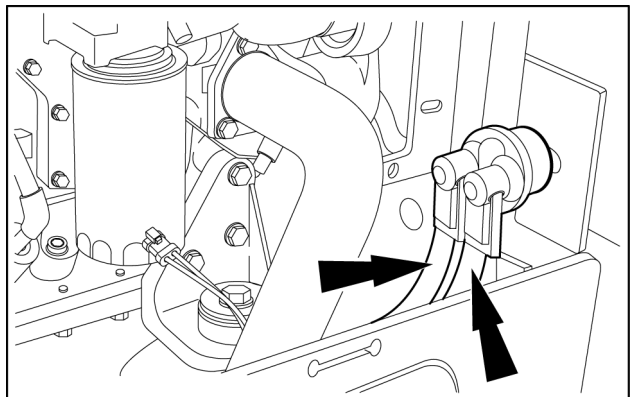

LEIL15WHL0307AB 57

65. Remove the four bolts **(3)** and the four washers **(4)** to remove the support structures **(1)** from the rear chassis **(2)**.

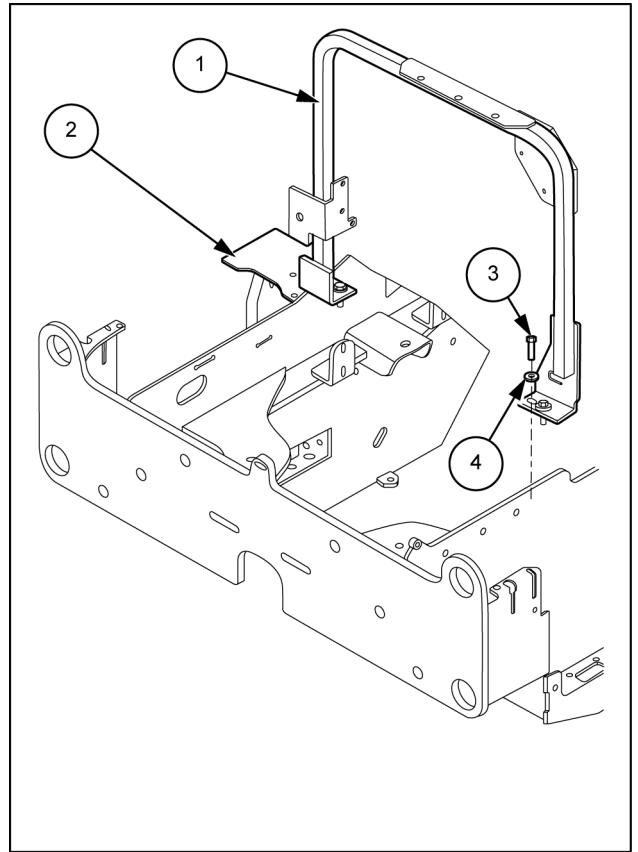

LEIL15WHL0262BB 58

66. Loosen the clamp on the intake manifold that secures the after cooler output hose.

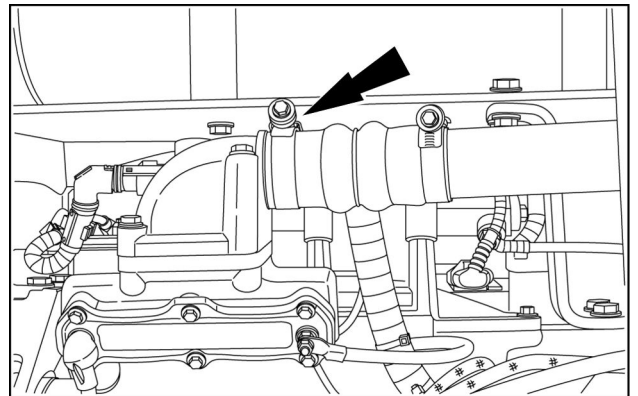

RAPH12WEL1464AA 59

67. Loosen the clamp **(2)** on the after cooler and remove the output hose **(1)** of the after cooler from the inter-cooler.

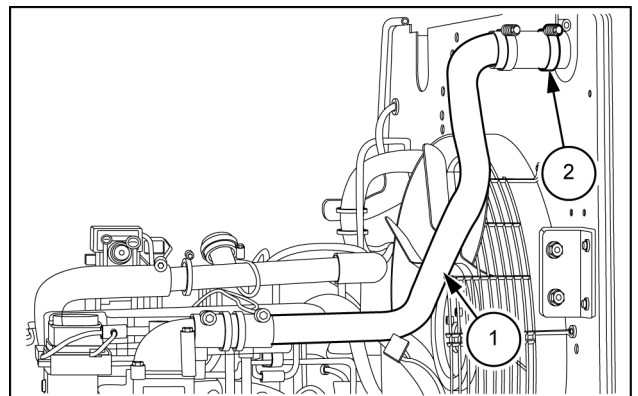

LEIL15WHL0277AB 60



**Suggest:**

**If the above button click is invalid.**

**Please download this document**

**first, and then click the above link**

**to download the complete manual.**

**Thank you so much for reading**

68. Remove the cooling fan screen (3) and the bottom cooling fan screen (2) removing the four bolts (1) and the related nuts.

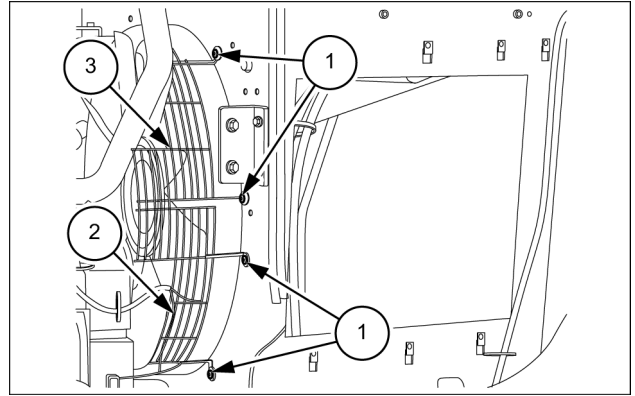

LEIL15WHL0301AB 61

69. Loosen the clamps (1) and (2) to remove the bottom hose coolant (3) from the engine.

**NOTE:** the battery cover plate has been hidden for clarify.

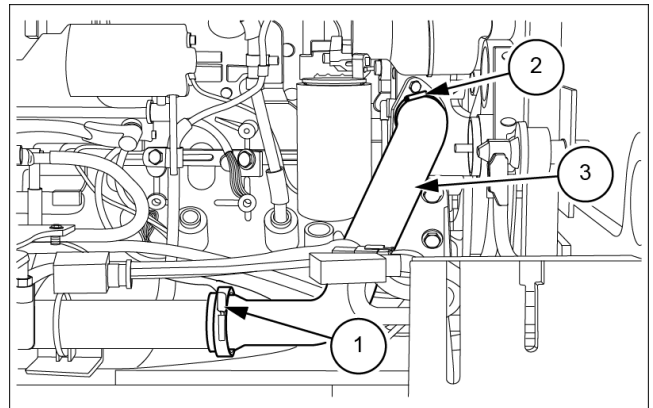

LEIL15WHL0278AB 62

70. Cut the tie straps (1) and remove the clamp (4). Separate the breather hose (3) from the radiator hose (2). Loosen clamp (6) from the hose (5). Loosen clamp on the engine then remove the hose (5).

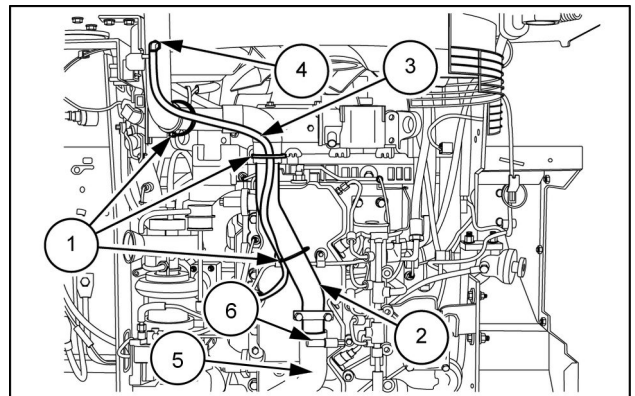

LEIL15WHL0279AB 63

71. Remove the nuts (2) from the U-bolt clamp, to separate the radiator hose (3) from the bracket (1).

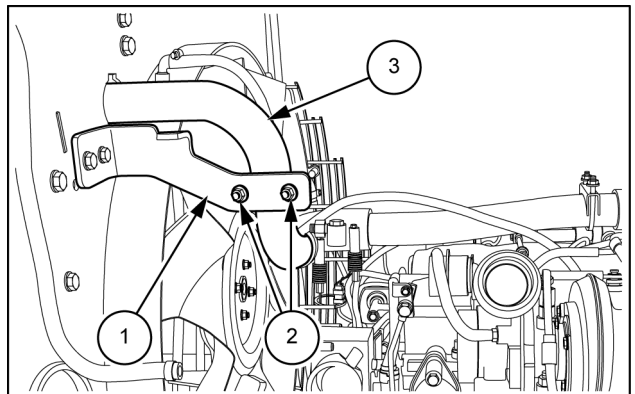

LEIL15WHL0280AB 64

**<https://www.ebooklibonline.com>**

Hello dear friend!

Thank you very much for reading.

Enter the link into your browser.

The full manual is available for immediate download.

**<https://www.ebooklibonline.com>**