

**521F**  
**Tier 4**  
Wheel Loader

**SERVICE MANUAL**

**Part number 47462778**  
1<sup>st</sup> edition English  
January 2013



# Contents

---

## INTRODUCTION

Engine.....	10
[10.001] Engine and crankcase .....	10.1
[10.310] Aftercooler.....	10.2
[10.400] Engine cooling system .....	10.3
[10.414] Fan and drive .....	10.4
[10.500] Selective Catalytic Reduction (SCR) exhaust treatment.....	10.5
Transmission.....	21
[21.113] Powershift transmission .....	21.1
[21.135] Powershift transmission external controls.....	21.2
[21.145] Gearbox internal components.....	21.3
[21.155] Powershift transmission internal components.....	21.4
Four-Wheel Drive (4WD) system .....	23
[23.314] Drive shaft.....	23.1
Front axle system .....	25
[25.100] Powered front axle .....	25.1
[25.102] Front bevel gear set and differential .....	25.2
[25.310] Final drives .....	25.3
Rear axle system.....	27
[27.100] Powered rear axle.....	27.1
[27.106] Rear bevel gear set and differential.....	27.2
[27.120] Planetary and final drives .....	27.3
Brakes and controls .....	33
[33.110] Parking brake or parking lock .....	33.1
[33.202] Hydraulic service brakes .....	33.2
Hydraulic systems.....	35

[35.000] Hydraulic systems .....	35.1
[35.106] Variable displacement pump .....	35.2
[35.300] Reservoir, cooler, and filters.....	35.3
[35.357] Pilot system .....	35.4
[35.359] Main control valve .....	35.5
[35.701] Front loader arm hydraulic system .....	35.6
[35.752] Hydraulic fan drive cooling system.....	35.7
<b>Frames and ballasting .....</b>	<b>39</b>
[39.100] Frame .....	39.1
<b>41 - Steering .....</b>	<b>41</b>
[41.200] Hydraulic control components.....	41.1
[41.216] Cylinders .....	41.2
[41.910] Auxiliary steering .....	41.3
<b>Cab climate control .....</b>	<b>50</b>
[50.100] Heating .....	50.1
[50.200] Air conditioning.....	50.2
<b>Electrical systems .....</b>	<b>55</b>
[55.000] Electrical system .....	55.1
[55.011] Fuel tank system .....	55.2
[55.012] Engine cooling system .....	55.3
[55.015] Engine control system.....	55.4
[55.030] Service brake electrical system .....	55.5
[55.031] Parking brake electrical system .....	55.6
[55.036] Hydraulic system control .....	55.7
[55.047] Steering control system .....	55.8
[55.050] Heating, Ventilation, and Air-Conditioning (HVAC) control system.....	55.9
[55.051] Cab Heating, Ventilation, and Air-Conditioning (HVAC) controls.....	55.10
[55.100] Harnesses and connectors.....	55.11
[55.201] Engine starting system .....	55.12

**<https://www.ebooklibonline.com>**

Hello dear friend!

Thank you very much for reading.

Enter the link into your browser.

The full manual is available for immediate download.

**<https://www.ebooklibonline.com>**

[55.202] Cold start aid .....	55.13
[55.301] Alternator .....	55.14
[55.302] Battery.....	55.15
[55.404] External lighting .....	55.16
[55.405] External lighting switches and relays .....	55.17
[55.408] Warning indicators, alarms, and instruments .....	55.18
[55.415] Loader arm and bucket control system .....	55.19
[55.510] Cab/Platform harnesses and connectors .....	55.20
[55.512] Cab controls.....	55.21
[55.514] Cab lighting .....	55.22
[55.518] Wiper/Washer system.....	55.23
[55.519] Cab brake controls .....	55.24
[55.524] Cab controls (Lift arm, Boom, Dipper, Bucket).....	55.25
[55.988] Selective Catalytic Reduction (SCR) electrical system .....	55.26
[55.DTC] FAULT CODES.....	55.27
<b>Platform, cab, bodywork, and decals .....</b>	<b>90</b>
[90.124] Pneumatically-adjusted operator seat.....	90.1



## **INTRODUCTION**

## Foreword - Ecology and the environment

521F NA

Soil, air, and water are vital factors of agriculture and life in general. When legislation does not yet rule the treatment of some of the substances required by advanced technology, sound judgment should govern the use and disposal of products of a chemical and petrochemical nature.

**NOTE:** *The following are recommendations that may be of assistance:*

- Become acquainted with and ensure that you understand the relative legislation applicable to your country.
- Where no legislation exists, obtain information from suppliers of oils, filters, batteries, fuels, antifreeze, cleaning agents, etc., with regard to their effect on man and nature and how to safely store, use, and dispose of these substances.
- Agricultural consultants will, in many cases, be able to help you as well.

### Helpful hints

- Avoid filling tanks using cans or inappropriate pressurized fuel delivery systems that may cause considerable spillage.
- In general, avoid skin contact with all fuels, oils, acids, solvents, etc. Most of them contain substances that may be harmful to your health.
- Modern oils contain additives. Do not burn contaminated fuels and or waste oils in ordinary heating systems.
- Avoid spillage when draining off used engine coolant mixtures, engine, gearbox and hydraulic oils, brake fluids, etc. Do not mix drained brake fluids or fuels with lubricants. Store them safely until they can be disposed of in a proper way to comply with local legislation and available resources.
- Modern coolant mixtures, i.e. antifreeze and other additives, should be replaced every two years. They should not be allowed to get into the soil, but should be collected and disposed of properly.
- Do not open the air-conditioning system yourself. It contains gases that should not be released into the atmosphere. Your CASE CONSTRUCTION dealer or air conditioning specialist has a special extractor for this purpose and will have to recharge the system properly.
- Repair any leaks or defects in the engine cooling or hydraulic system immediately.
- Do not increase the pressure in a pressurized circuit as this may lead to a component failure.
- Protect hoses during welding as penetrating weld splatter may burn a hole or weaken them, allowing the loss of oils, coolant, etc.

---

## Personal safety

521F NA

Most accidents involving machine operation and maintenance can be avoided by following basic safety rules and precautions. Read and understand all the safety messages in this manual, the safety manual and the safety signs on the machine before you operate or service the machine. See your dealer if you have any questions.

READ THIS MANUAL COMPLETELY and make sure you understand the controls. All equipment has a limit. Make sure you understand the speed, brakes, steering, stability, and load characteristics of the machine before you start to operate this machine.

DO NOT remove this manual or the safety manual from the machine. See your dealer for additional manuals. Also see the manual information on the Title pages (first and second pages in front of the Table of Contents) of this manual.

The safety information given in this manual does not replace safety codes, insurance needs, federal, state, or local laws. Make sure that your machine has the correct equipment according to these rules or laws.

Additional safety messages are used in the text of the manual to show specific safety hazards.

**NOTICE:** *The safety messages in this chapter point out conditions which can happen during the normal operation and maintenance of your machine. These safety messages also give possible ways of dealing with these conditions.*

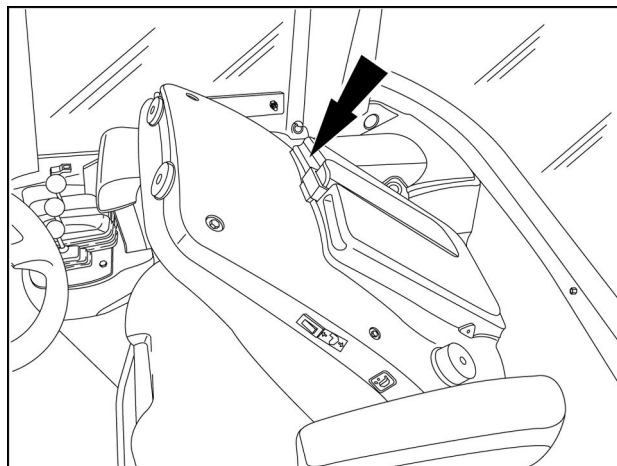

RCPH11WHL0030AA 1

## Safety rules

521F NA

### **General Safety Rules**

Use caution when operating the machine on slopes. Raised equipment, full tanks and other loads will change the center of gravity of the machine. The machine can tip or roll over when near ditches and embankments or uneven surfaces.

Never permit anyone other than the operator to ride on the machine.

Never operate the machine under the influence of alcohol, drugs, or while otherwise impaired.

Never allow riders on the machine.

When digging or using ground engaging attachments, be aware of buried cables. Contact local utilities to determine the locations of services.

Pay attention to overhead power lines and hanging obstacles. High voltage lines may require significant clearance for safety.

Hydraulic oil or diesel fuel leaking under pressure can penetrate the skin, causing serious injury or infection.

- DO NOT use your hand to check for leaks. Use a piece of cardboard or paper.
- Before connecting or disconnecting fluid lines, always stop the engine, remove the key, and relieve the fluid line pressure.
- Ensure all components are in good condition. Tighten all connections before starting the engine or pressurizing the system.
- If the hydraulic fluid or diesel fuel penetrates the skin, seek medical attention immediately.
- Continuous long term contact with hydraulic fluid may cause skin cancer. Avoid long term contact and promptly wash the skin with soap and water.

Keep clear of moving parts. Loose clothing, jewelry, watches, long hair, and other loose or hanging items can become entangled in moving parts.

Wear protective equipment when appropriate.

DO NOT attempt to remove material from any part of the machine while it is being operated or components are in motion.

Ensure all guards and shields are in good condition and properly installed before operating the machine. Never operate the machine with shields removed. Always close access doors or panels before operating the machine.

Dirty or slippery steps, ladders, walkways, and platforms can cause falls. Ensure these surfaces remain clean and clear of debris.

A person or pet within the operating area of a machine can be struck or crushed by the machine or its equipment. DO NOT allow anyone to enter the work area.

Raised equipment and/or loads can fall unexpectedly and crush persons underneath. Never allow anyone to enter the area underneath raised equipment during operation.

Never operate the engine in enclosed spaces, as harmful exhaust gases may build up.

Before starting the machine, ensure that all controls are in neutral or park lock position.

Start the engine only from the operator's seat. If the safety start switch is bypassed, the engine can start with the transmission in gear. DO NOT connect or short across terminals on the starter solenoid. Attach jumper cables as described in the manual. Starting in gear may cause death or serious injury.

Always keep windows, mirrors, all lighting, and the Slow Moving Vehicle (SMV) emblem clean to provide the best possible visibility while operating the machine.

# **CASE**

**CONSTRUCTION**

## **SERVICE MANUAL**

### **Engine**

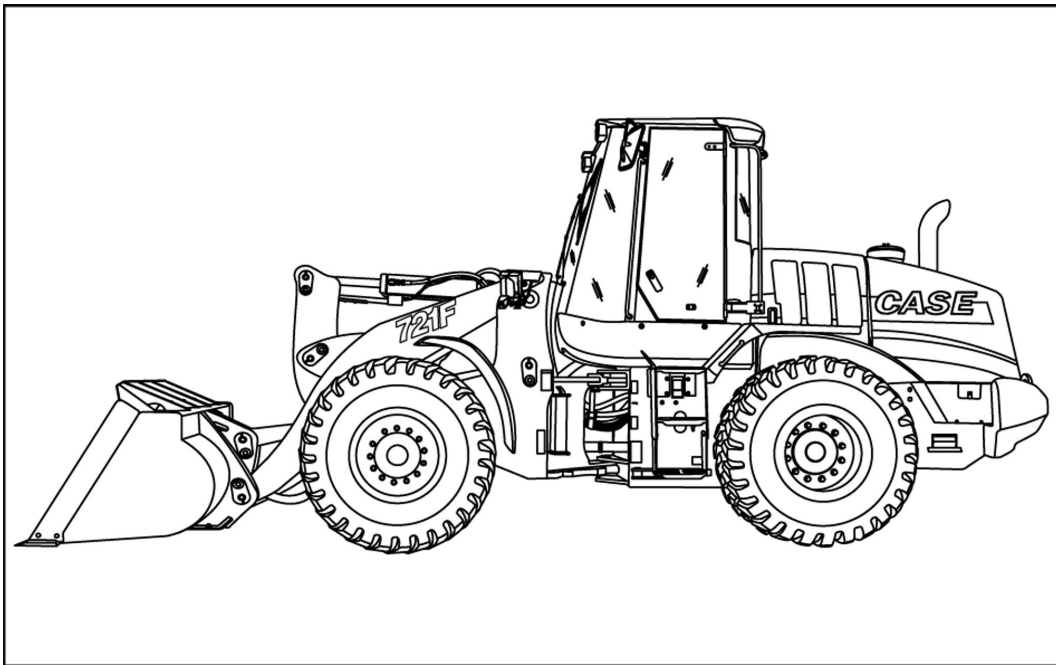

**521F NA**

## Engine - Remove

1. Park the machine on a level surface. Lower the bucket to the ground. Put the articulation lock in the LOCKED position.

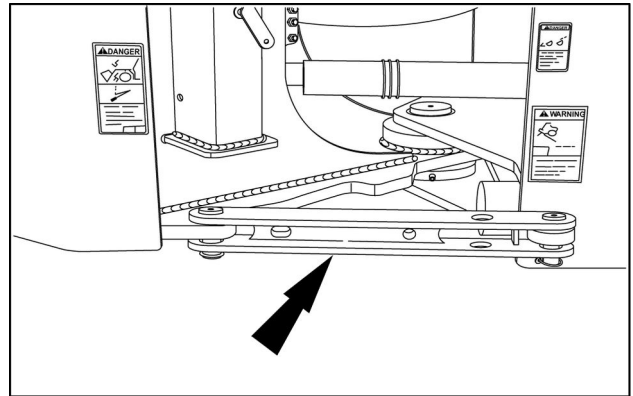

RAPH12WEL1412AA 1

2. Turn the engine OFF. Actuate the brake pedal several times to discharge the brake accumulators. Turn the key switch to the ON position. Move the loader control lever back and forth minimally 30 times to release pressure from the hydraulic circuit. Turn the key switch to the OFF position.
3. Slowly loosen the hydraulic reservoir filler cap to release air pressure in the hydraulic reservoir.
4. Raise the machine hood and turn the master disconnect switch to the OFF position. The master disconnect switch is located under the machine hood on the left side of the machine.

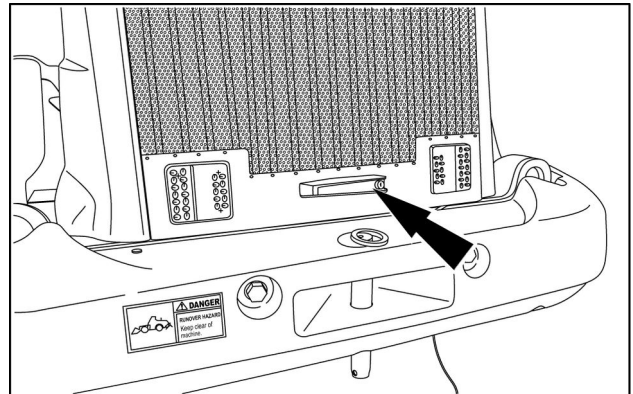

RAPH12WEL1493AA 2

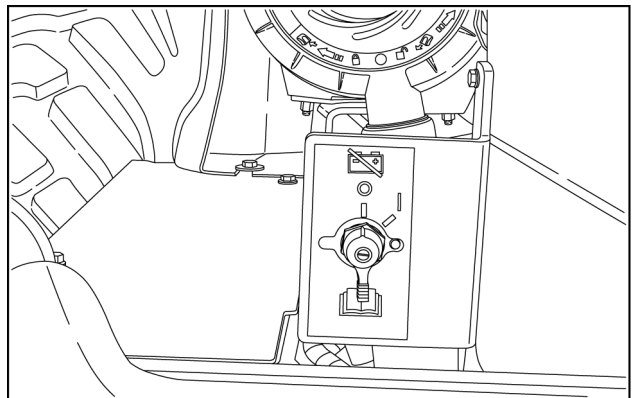

RAPH12WEL1457AA 3

5. Remove both battery covers. Disconnect the batteries from the machine.

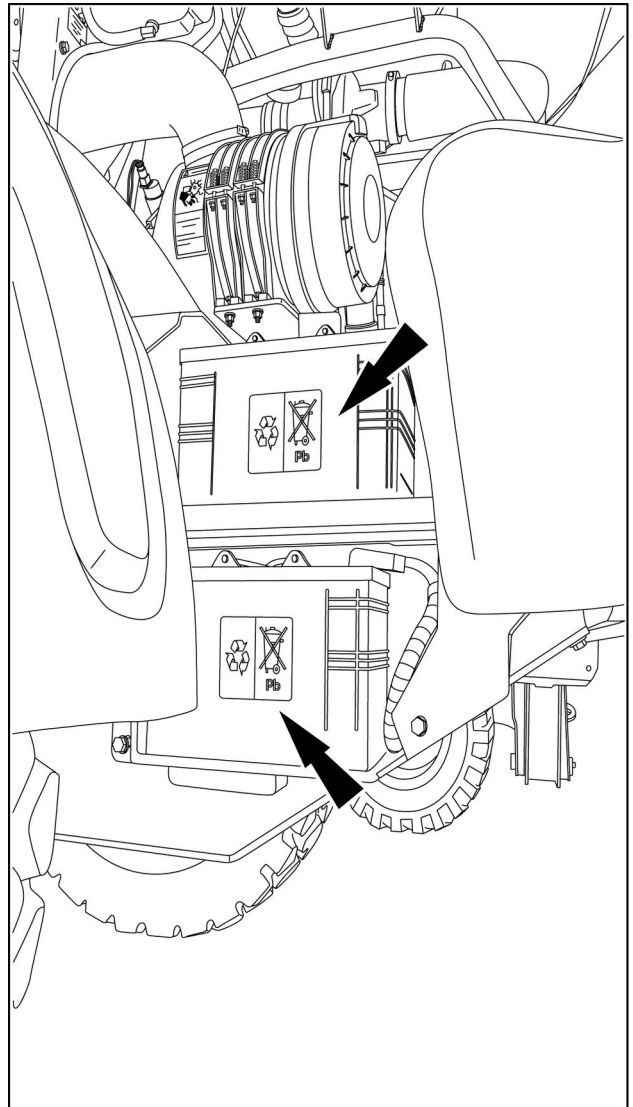

RAPH12WEL1495CA 4

6. Loosen the screw (1) and open the access cover (2).

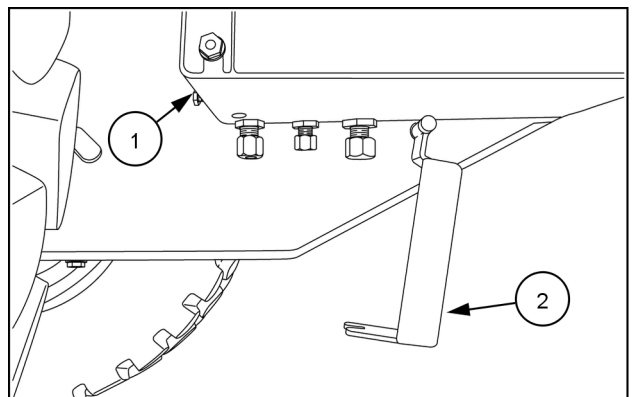

RAPH12WEL1494AA 5

7. Place a container capable of holding at least **22.7 l (6.0 US gal)** below the radiator drain. Remove the drain plug (1) and radiator cap. Drain the coolant into the container. After the coolant has drained, install the radiator cap. Place a container capable of holding at least **12.3 l (3.2 US gal)** below the engine oil drain. Remove the engine oil cap (2). Drain engine oil into the container. After the engine oil has drained, install the engine oil cap.

**NOTE:** After draining the engine oil, disconnect the drain hose from the frame to aid in removal of engine.

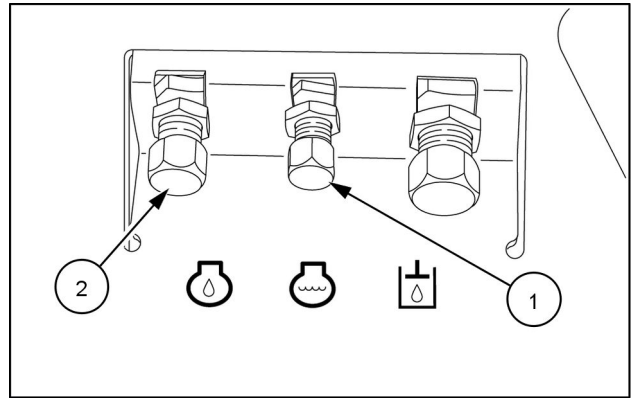

RAPH12WEL1411AA 6

8. Double up a nylon lifting strap (1) and slide the strap through the exhaust stack (2), located on the hood.

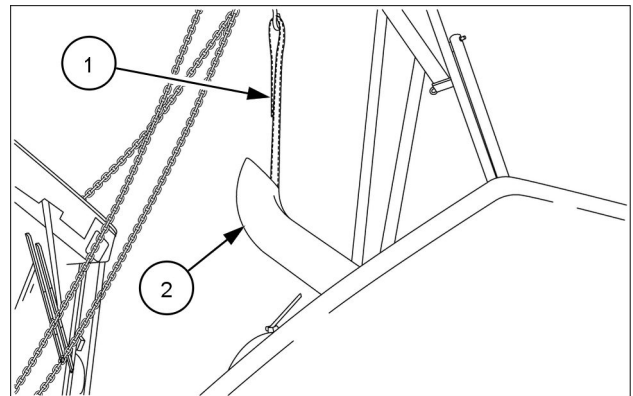

RAPH12WEL1428AA 7

9. Place a solid steel bar through the nylon strap. Raise the hood and release the tension on the lifting motor.

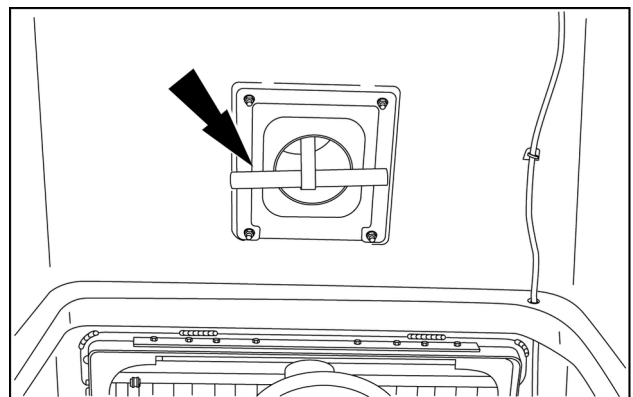

RAPH12WEL1458AA 8

10. Remove the right front lift cylinder from the hood. Repeat the procedure for the left side to remove the left front lift cylinder.

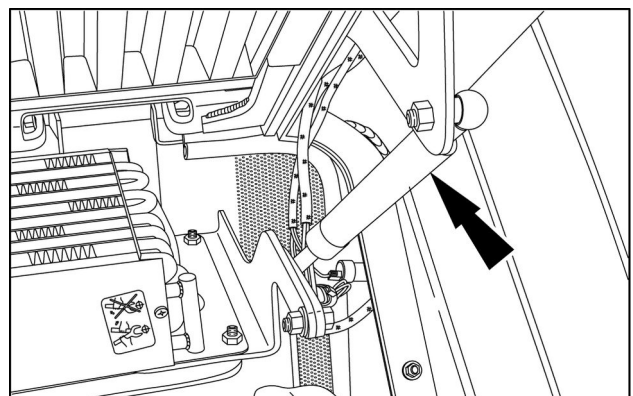

RAPH12WEL1489AA 9

11. Remove the rear lift cylinder from the machine.

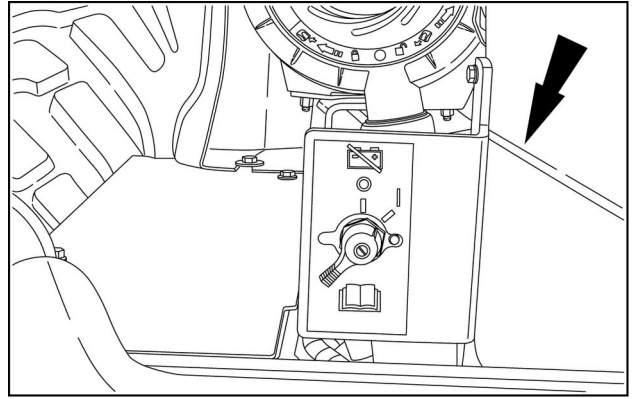

RAPH12WEL1456AA 10

12. Disconnect the hood wiring harness connector and backup alarm connector from the rear chassis wiring harness connector. Identify and tag the connectors to aid in reassembly.

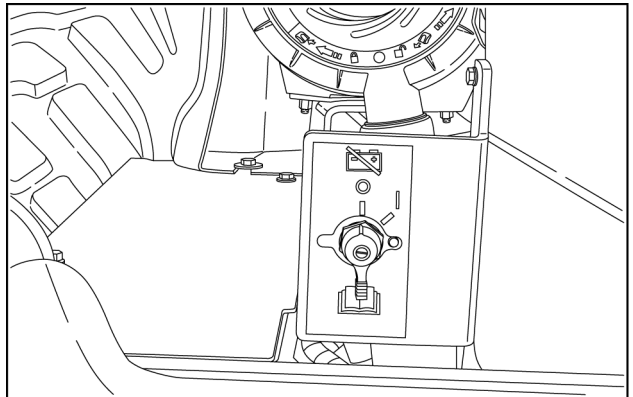

RAPH12WEL1457AA 11

13. With the assistance of another technician, balance the hood and remove the hood hinge mounting bolts (1) near the cab (2) from the cooler frame. Repeat the procedure for the other side.

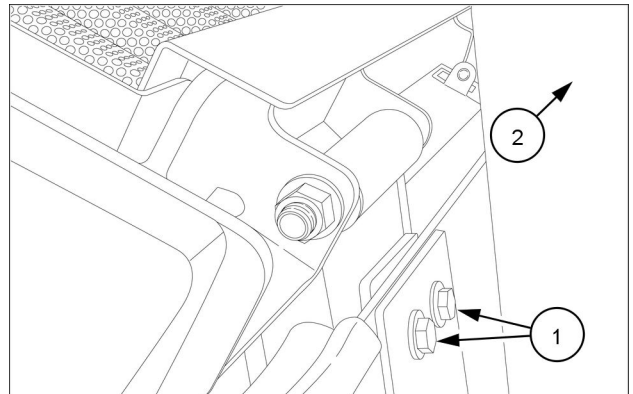

RAPH12WEL1461AA 12

14. Carefully raise and remove the hood from the machine. Lower the hood onto a suitable platform. Disconnect the lifting equipment.

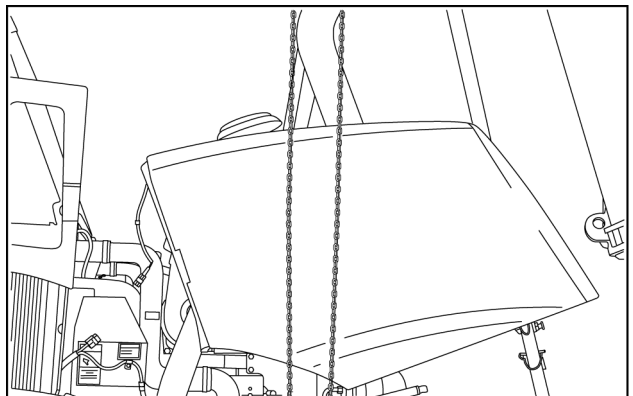

RAPH12WEL1429AA 13

15. Disconnect the engine wiring harness connector from the air filter restriction switch. Identify and tag the connector to aid in reassembly.

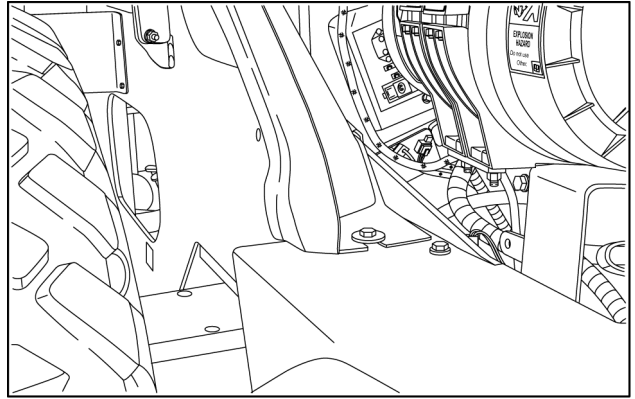

RAPH12WEL1485AA 14

16. Loosen the clamp on the air cleaner intake hose. Remove the crankcase ventilation hose.
17. Loosen the clamps on the turbocharger and the air cleaner. Remove the intake hose.

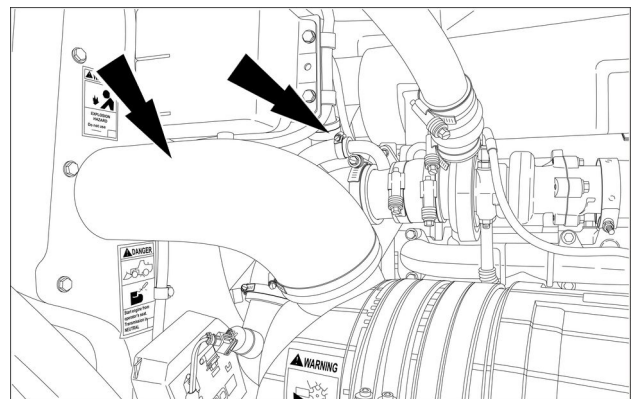

RAPH12WEL1463AA 15

18. Remove the air cleaner by removing the four bolts.

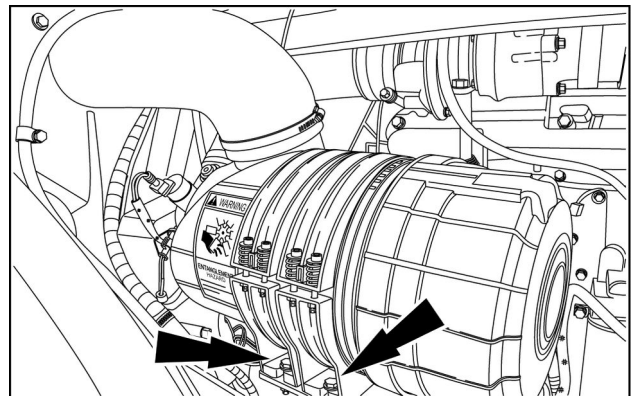

RAPH12WEL1499AA 16

19. Loosen the clamp on the turbocharger for the after-cooler inlet hose.

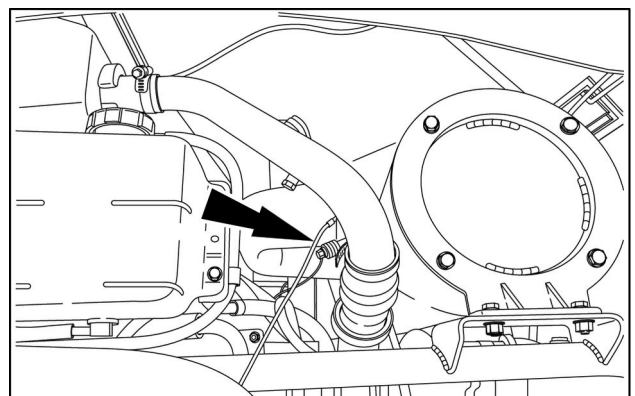

RAPH12WEL1500AA 17

20. Loosen the clamp on the aftercooler. Remove the aftercooler inlet hose from the machine

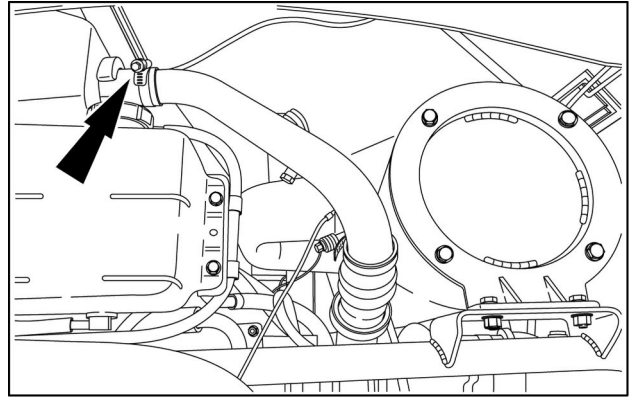

RAPH12WEL1500AA 18

21. Loosen the clamp on the intake manifold that secures the aftercooler output hose.

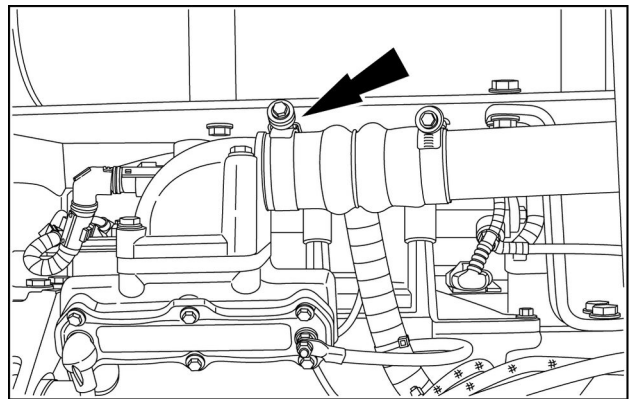

RAPH12WEL1464AA 19

22. Loosen the clamp on the aftercooler. Remove the aftercooler outlet hose from the machine.

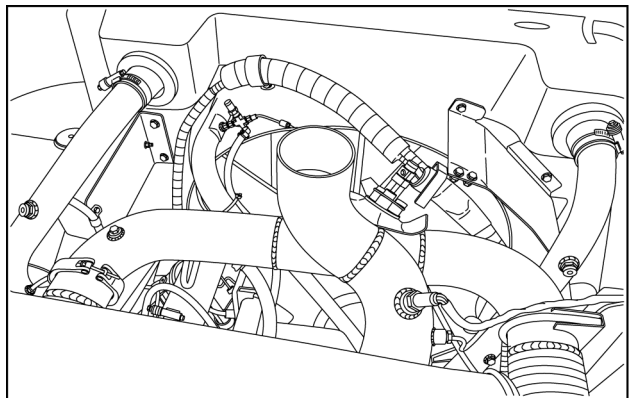

RAPH12WEL1501AA 20

23. Loosen the exhaust clamp from the turbocharger.

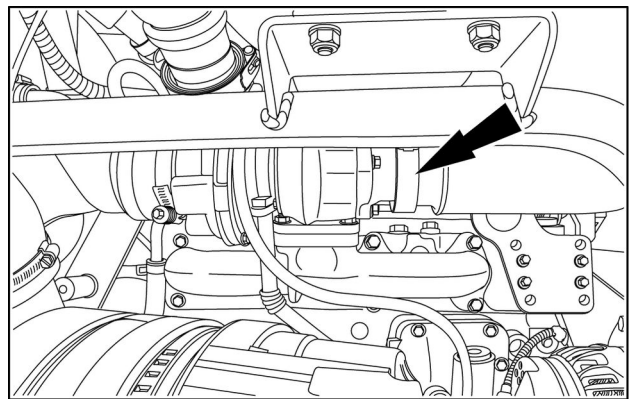

RAPH12WEL1502AA 21

24. Disconnect the electrical connector from the exhaust sensor, located before the SCR catalyst .

25. Disconnect the electrical connector from the exhaust temperature sensor, located after the SCR catalyst. Disconnect two hoses from the dosing unit injector. Disconnect the electrical connector. Identify and tag the connectors to aid in reassembly.
26. Disconnect the NOx sensor module (1) from the machine wiring harness. Remove the hex bolts (2) securing the NOx sensor module to the mounting support bracket. Remove the NOx sensor module.

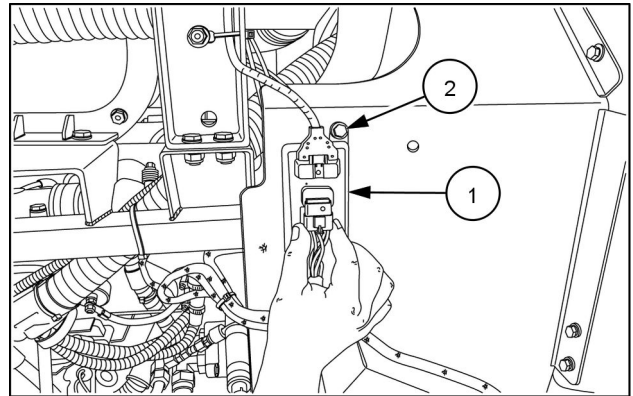

RAPH12WEL1508AA 22

**NOTE:** Use the following illustration to aid in removal of components.

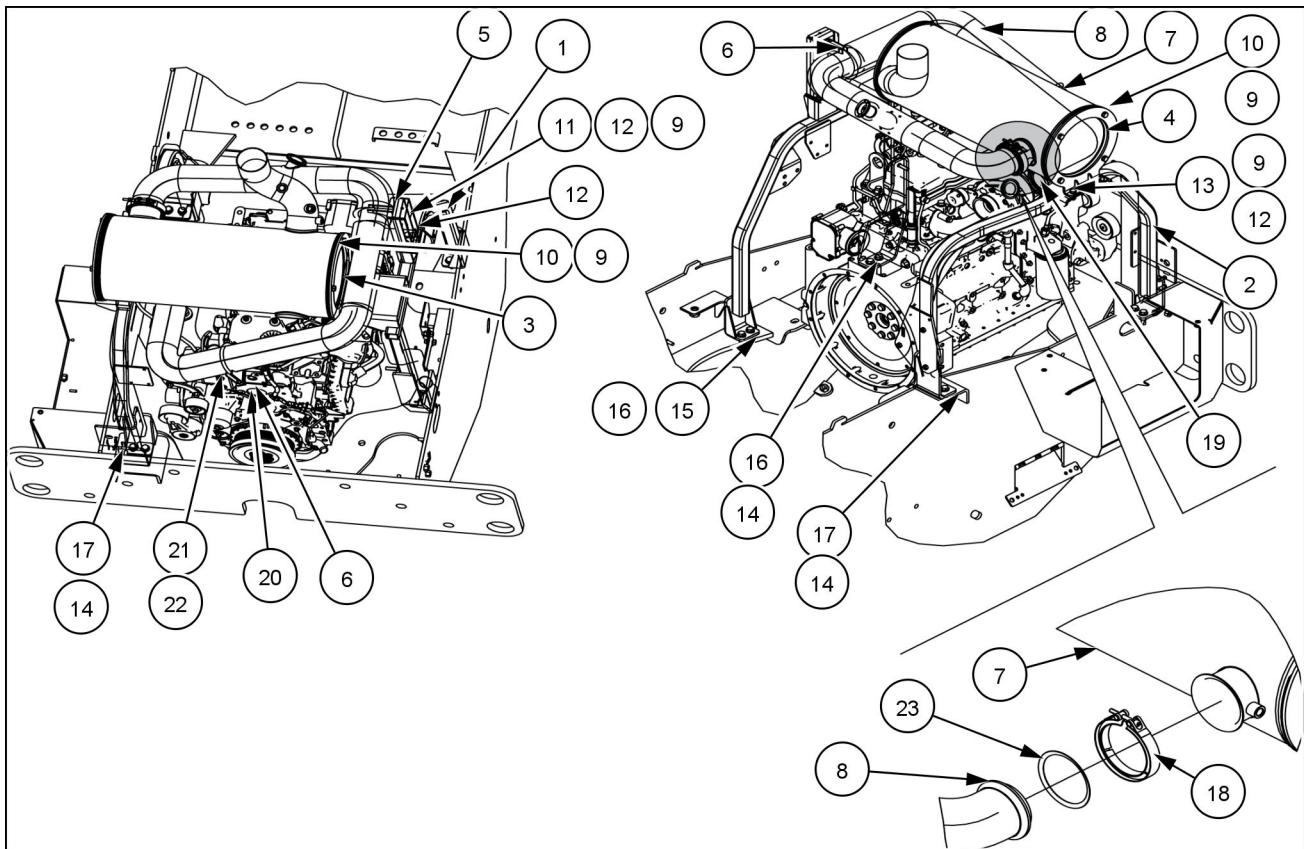

RAIL13WEL0094FA 23

**Graphic Legend**

- |                          |                                 |                              |
|--------------------------|---------------------------------|------------------------------|
| 1. Support, muffler (RH) | 9. Washer (10.5 x 18 x 1.6 mm)  | 17. Bolt (M12 x 45)          |
| 2. Support, muffler (LH) | 10. Bolt (M10 x 20)             | 18. Clamp                    |
| 3. Bracket, muffler (RH) | 11. Bolt (M10 x 25)             | 19. Retaining strap          |
| 4. Bracket, muffler (LH) | 12. Nut (M10)                   | 20. Bracket                  |
| 5. Bracket               | 13. Bolt (M10 x 30)             | 21. Washer (9 x 21 x 2.5 mm) |
| 6. Muffler clamp         | 14. Washer (13.5 x 24 x 2.5 mm) | 22. Bolt (M8 x 25)           |
| 7. SCR catalyst          | 15. Bolt (M12 x 50)             | 23. Seal                     |
| 8. Pipe exhaust system   | 16. Bolt (M12 x 65)             |                              |

27. Loosen two bolt clamp muffler **(6)** from brackets (Items 5 through 20). Remove eight mounting bolts **(10)** from brackets **(4)** on left side and right side (four on each side). Remove the SCR muffler **(7)** from the brackets.
28. Remove the four mounting bolts (Items 17 thru 15) (two on each side). Remove the left and right support muffler **(1)** **(2)**.
29. Remove the DENOX urea supply electrical connections, located on the bottom of the ECU.

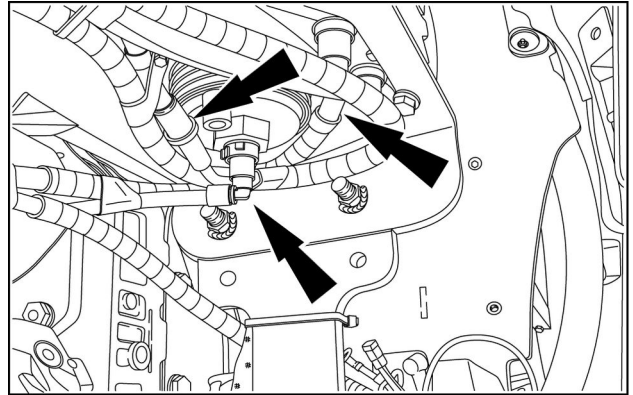

RAPH12WEL1509AA 24

30. Remove the DENOX urea supply electrical connections, located at the rear of the ECU.

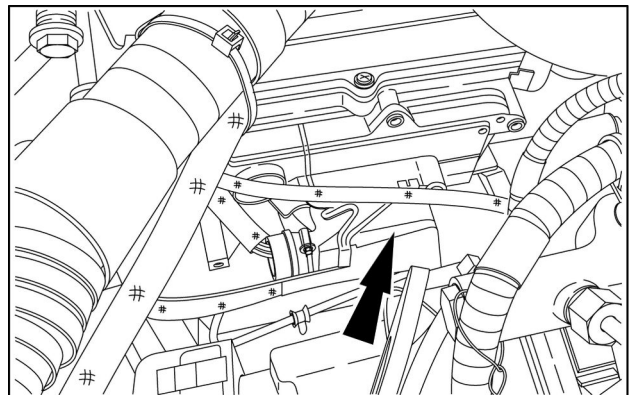

RAPH12WEL1510AA 25

31. Remove the four mounting bolts from the belt cover. Remove the cover. Disconnect the master switch wiring.

**NOTE:** After removing the belt cover, remove the belt cover mounting brackets from the machine frame.

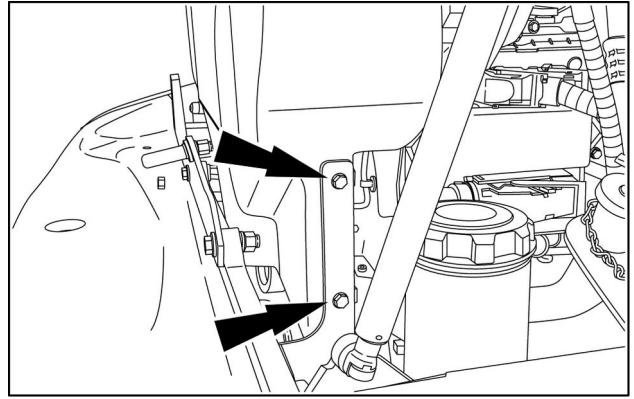

RAPH12WEL1492AA 26

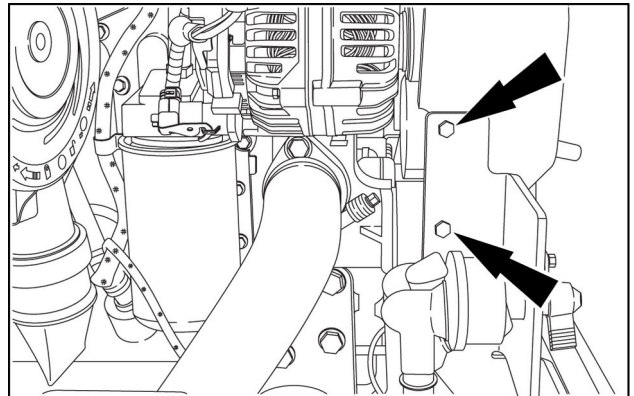

RAPH12WEL1467AA 27

32. Remove the drive belt from the engine.

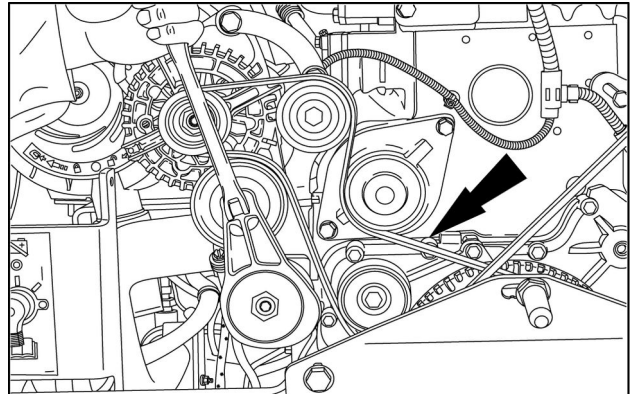

RAPH12WEL1469AA 28

33. Loosen the clamps and remove the lower cooler hose from the engine.

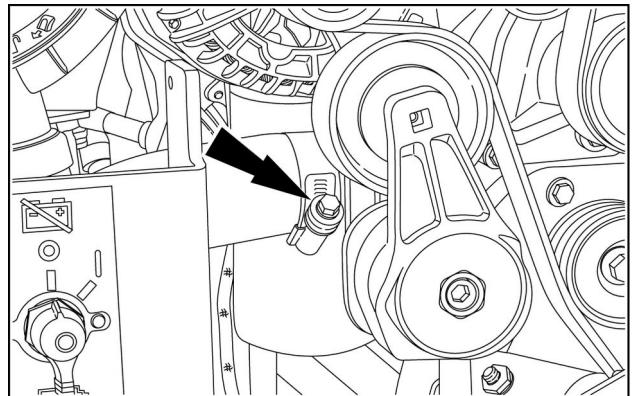

RAPH12WEL1470AA 29

34. If the machine is equipped with air conditioning, disconnect the engine wiring harness connectors from the air compressor clutch connector (1). Identify and tag the connectors to aid in reassembly. Remove the two mounting bolts (2) for the compressor. Set the compressor on the left battery cover.

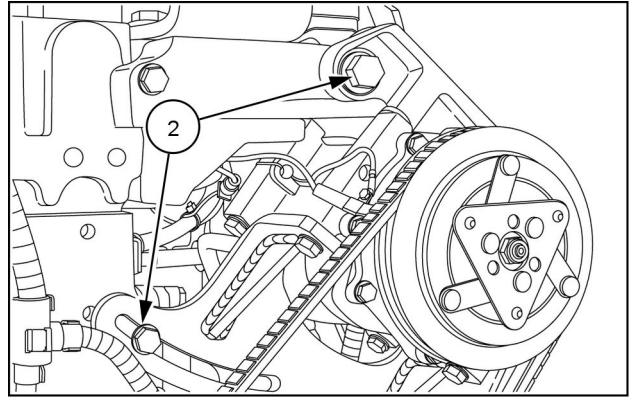

RAPH12WEL1472AA 30

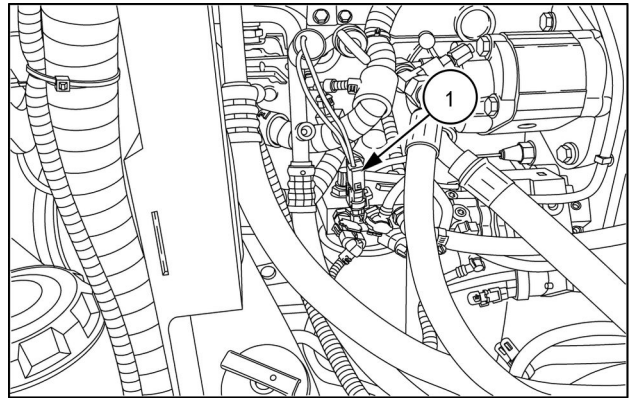

RAPH12WEL1505AA 31

35. Disconnect the wiring from the alternator. Identify and tag the wires to aid in reassembly.

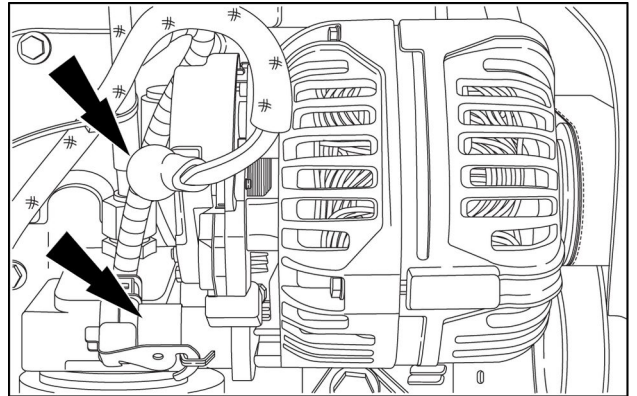

RAPH12WEL1468AA 32

36. Remove the bolt securing the wiring harness clamp (1) to the engine. Remove ground wires (2) from the engine.

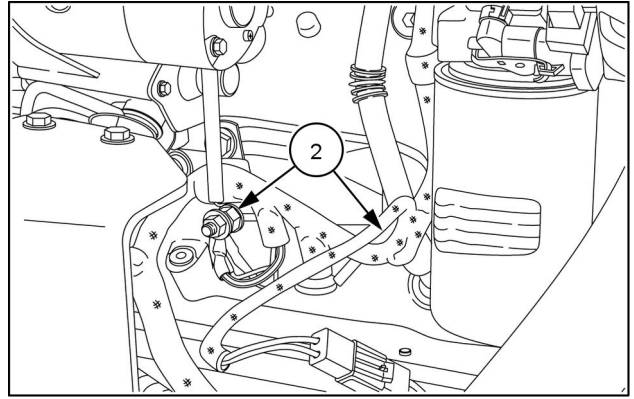

RAPH12WEL1473AA 33

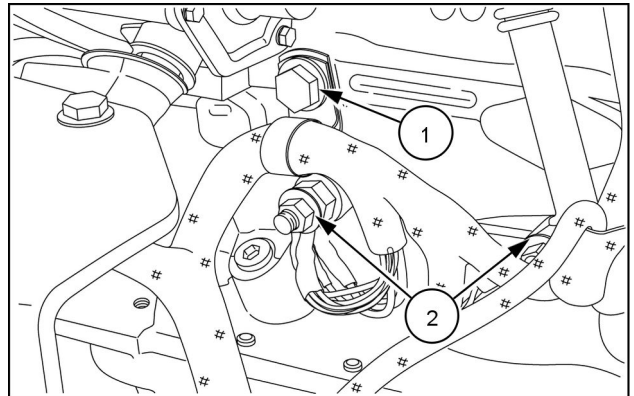

RAPH12WEL1475AA 34

37. Remove the wires from the starter solenoid (2). Remove the ground cable and cable strap (3) from the starter. Remove the two mounting bolts (1).

**NOTE:** Move the starter cables and the wiring harness away from the engine.

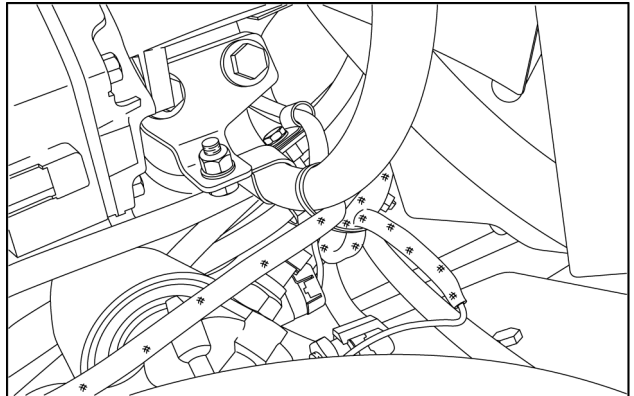

RAPH12WEL1477AA 35

38. Disconnect the engine coolant vent hose. Route the hose to the rear of the engine.

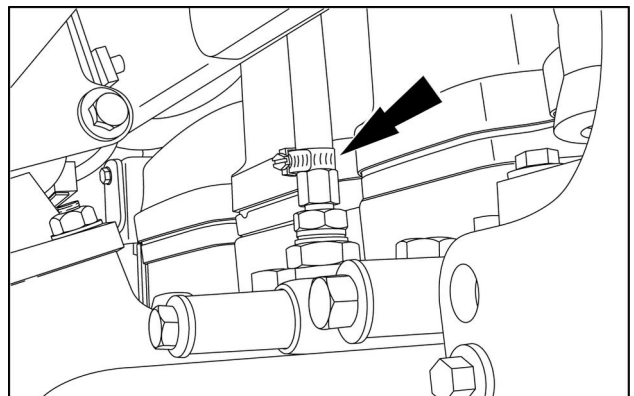

RAPH12WEL1491AA 36

39. Remove the radiator hose (1) and heater hose (2) from the rear of the engine. Remove the clamp bolts and clamps from the bell housing.

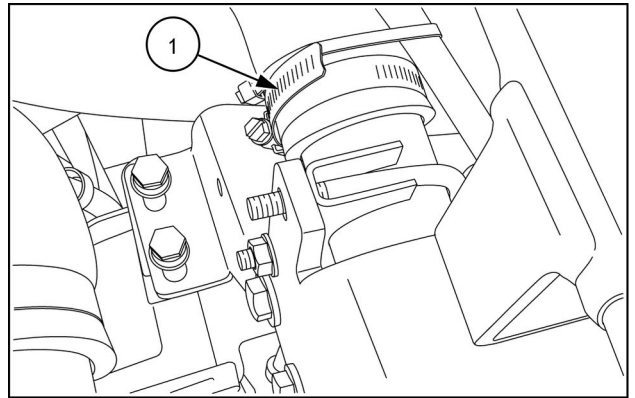

RAPH12WEL1488AA 37

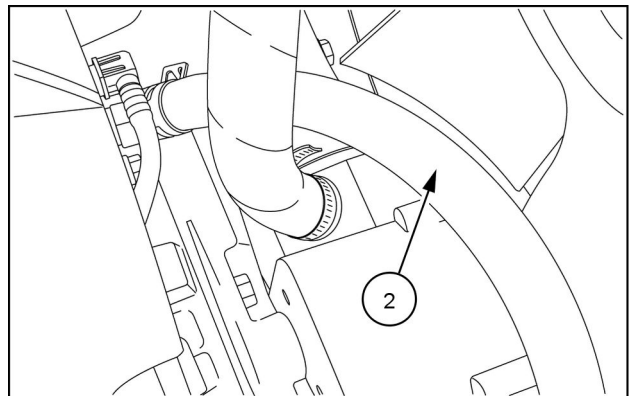

RAPH12WEL1476AA 38

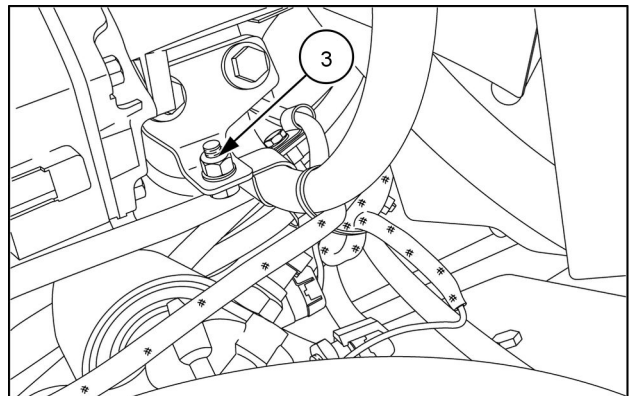

RAPH12WEL1477AA 39

40. Remove the grid heater cable. Tag the cable to aid in reassembly.

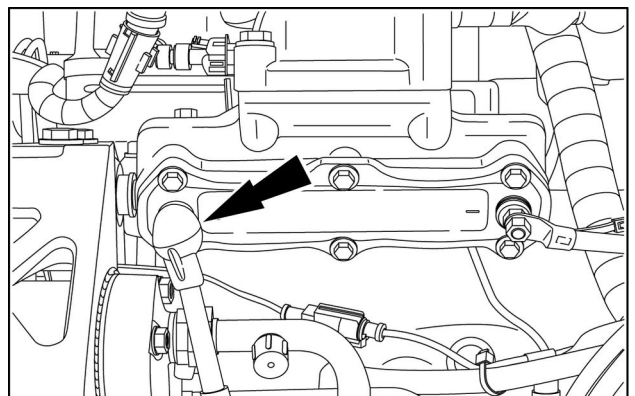

RAPH12WEL1478AA 40

41. Disconnect the wiring harness from the EDC 7 controller.

**NOTE:** Lifting up on the lever will release the connector from controller.

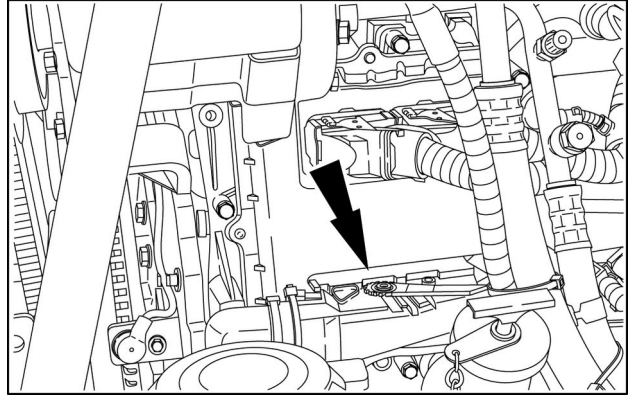

RAPH12WEL1479AA 41

42. Remove the fuel line from the top of the EDC 7 controller. Plug the line and cap the fitting.

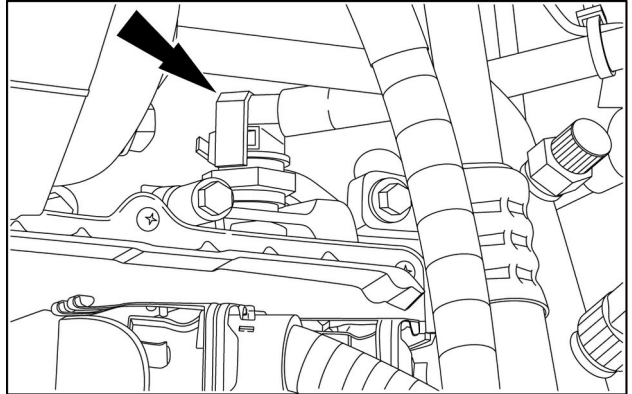

RAPH12WEL1483AA 42

43. Disconnect the fuel filter heater wires (1). Disconnect the fuel line (2) from the fuel filter head. Plug the line and cap the fitting.

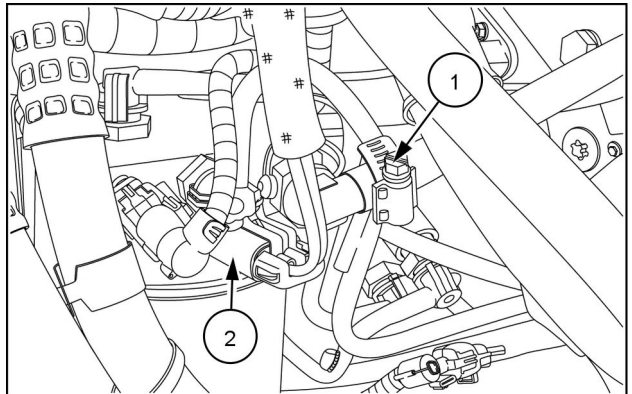

RAPH12WEL1490AA 43

44. Connect a vacuum pump to the hydraulic reservoir. Turn the vacuum on. Tag and remove the hydraulic lines from the brake system pump. Plug the lines and cap the fitting.

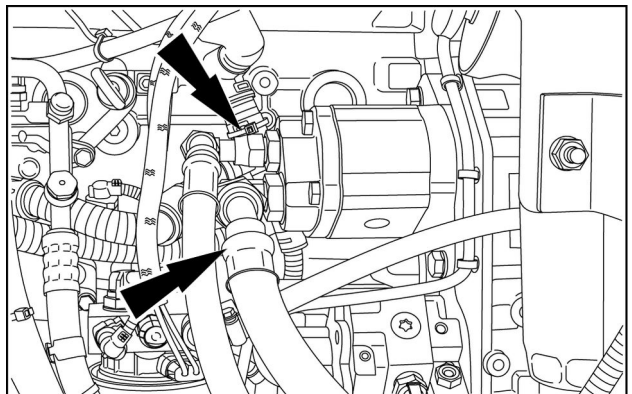

RAPH12WEL1480AA 44

45. Remove the lower cover to the drive shaft.

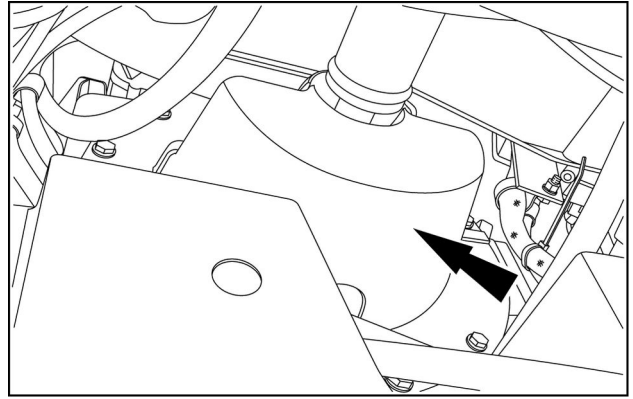

RAPH12WEL1481AA 45

46. Remove the drive shaft bolts from the flywheel. Move the drive shaft clear of the flywheel.

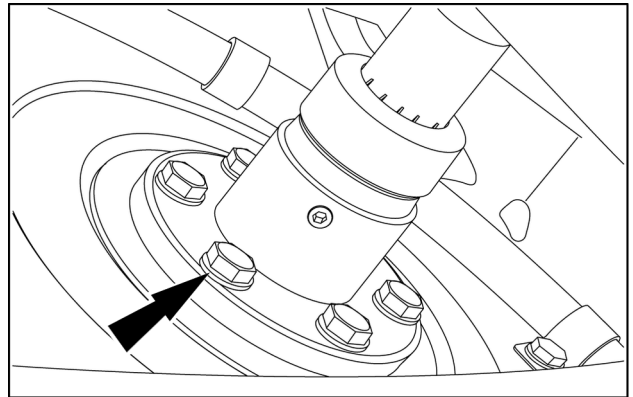

RAPH12WEL1421AA 46

47. Connect a suitable lifting device to the engine lifting eye. Ensure there is no slack in lifting chain. Remove the engine mounting bolts and lift the engine enough to gain access to the drain hose. Remove the engine oil drain hose with the engine.
48. Slowly raise the engine from the rear chassis. Ensure all harness connections and hoses have been disconnected and are clear of the engine. Remove the engine from the machine.

## Engine - Install

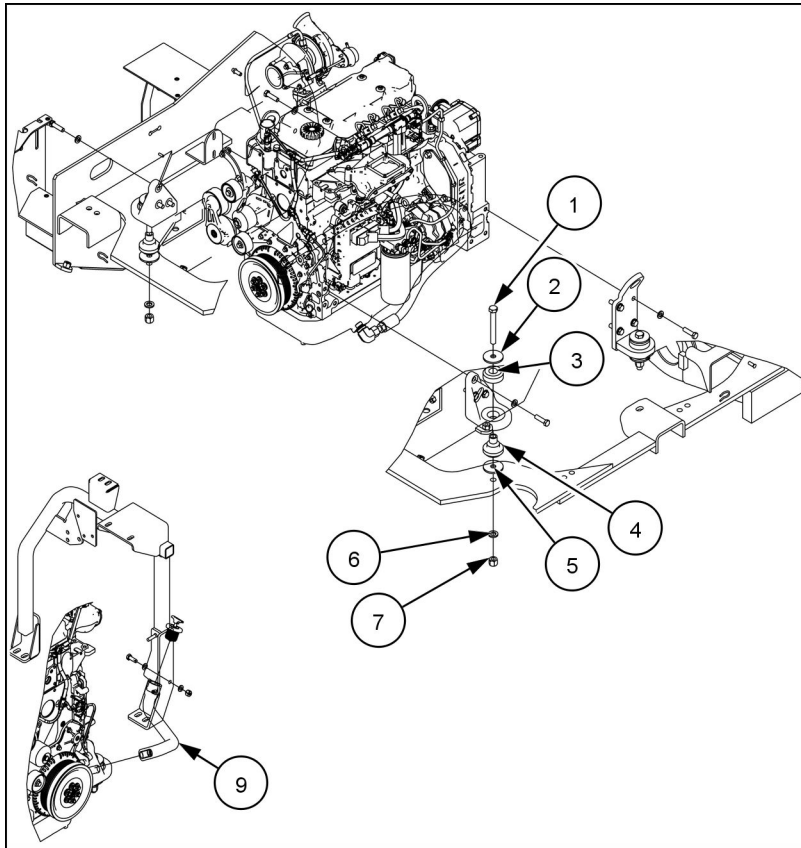

RAIL13WEL0096FA 1

### Graphic Legend

- |                      |                    |                          |
|----------------------|--------------------|--------------------------|
| 1. Engine mount bolt | 4. Lower insulator | 7. Nut                   |
| 2. Washer            | 5. Washer          | 8. Remote oil drain hose |
| 3. Upper insulator   | 6. Washer          | 9. Oil fill tube         |

1. Inspect engine rubber isolators **(3) (4)** for excessive wear or damage. Replace as required. Install lower insulator **(4)** first, then install upper insulator **(3)**.
2. Slowly raise the engine and move into position over the rear chassis. Ensure all harness connections and hoses are free and clear from chassis. Carefully lower the engine into the rear chassis. Install washer **(5)** between the lower insulator **(4)** and the chassis. Install washer **(2)**, bolt **(1)**, washer **(6)**, and nut **(7)** in engine isolators. Carefully lower and set engine in place.
3. Tighten engine mounting bolts to a torque of **244 - 298 N·m (180 - 220 lb ft)**
4. Disconnect the lifting equipment from lifting brackets.
5. Connect engine oil drain hose to the engine frame bracket.

6. At the front of the engine, position drive shaft on the engine coupling. Apply **LOCTITE® 242** to six bolts and install to secure the drive shaft to the engine coupling. Tighten the bolts to torque of **53 - 62 N·m (39 - 46 lb ft)**.

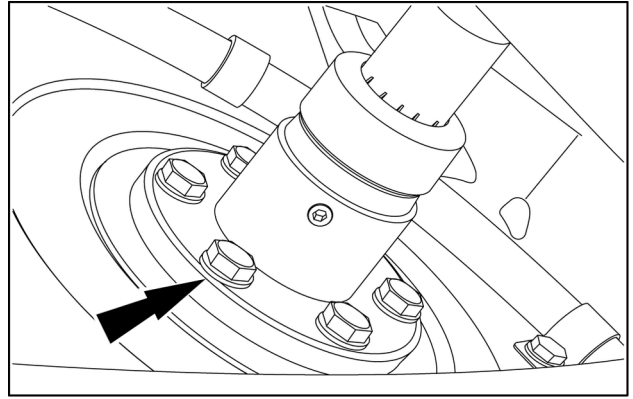

RAPH12WEL1421AA 2

7. Install the lower cover for the drive shaft.

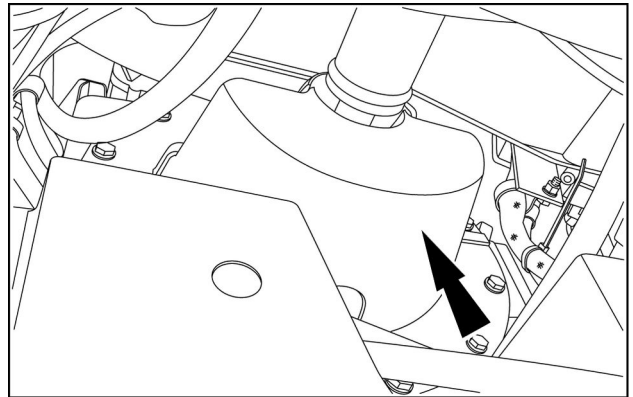

RAPH12WEL1481AA 3

8. Connect a vacuum pump to the hydraulic reservoir. Turn the vacuum on. Remove plugs from the lines and caps from the fittings. Connect hydraulic lines to the brake system pump. Refer to marked tags to ensure lines are correctly installed. Turn off the vacuum pump and disconnect from the hydraulic reservoir.

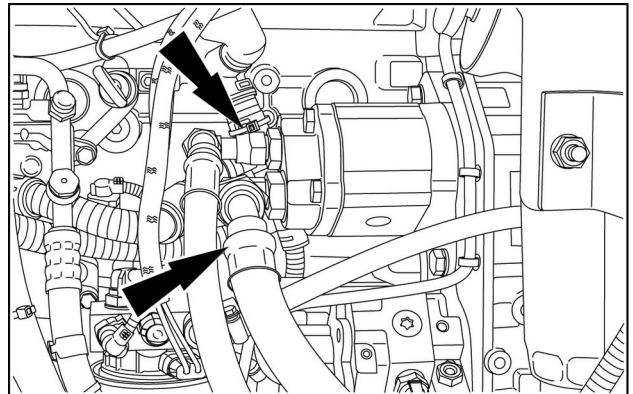

RAPH12WEL1480AA 4

9. Remove the plug from the line and the cap from the fitting. Connect the fuel line (2) to the fuel filter head. Disconnect the fuel filter heater wires (1). Refer to marked tag to ensure wires are installed correctly.

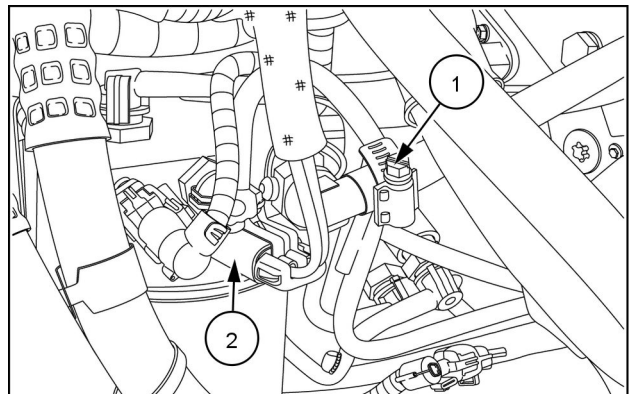

RAPH12WEL1490AA 5

10. Remove the plug from the hose and cap from the fitting. Connect the fuel line to EDC 7 controller.

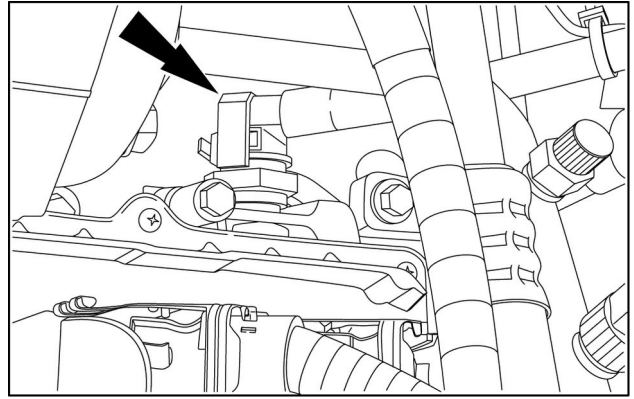

RAPH12WEL1483AA 6

11. Connect the wiring harness to the EDC 7 controller.

**NOTE:** Start the connector on the EDC 7 with the lever straight out from ECD 7. Use the lever to pull the connector into place.

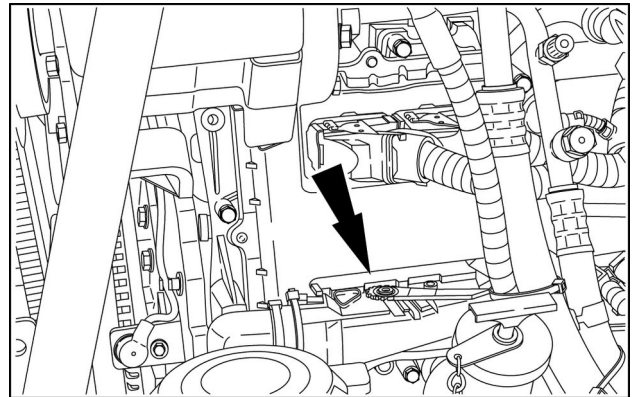

RAPH12WEL1479AA 7

12. Connect the grid heater cable to the grid heater. Refer to marked tag to ensure cable is installed correctly.

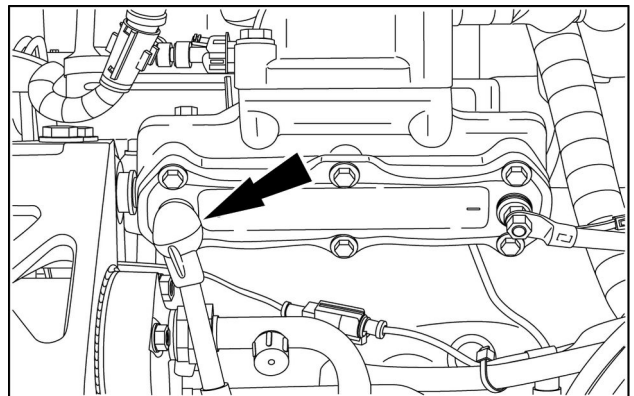

RAPH12WEL1478AA 8

13. Install the heater hose (2) to the rear of the engine. Mount the clamps (3). Install the radiator hose (1).

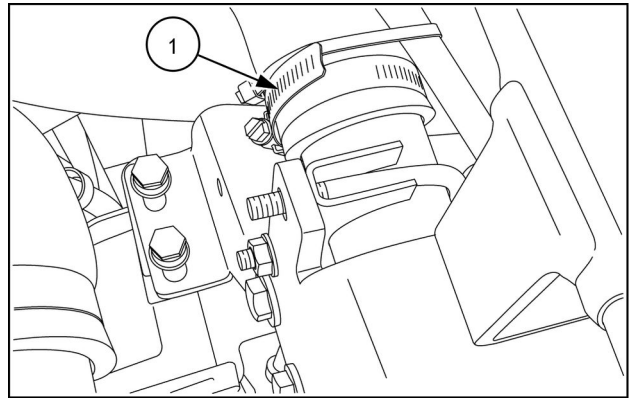

RAPH12WEL1488AA 9

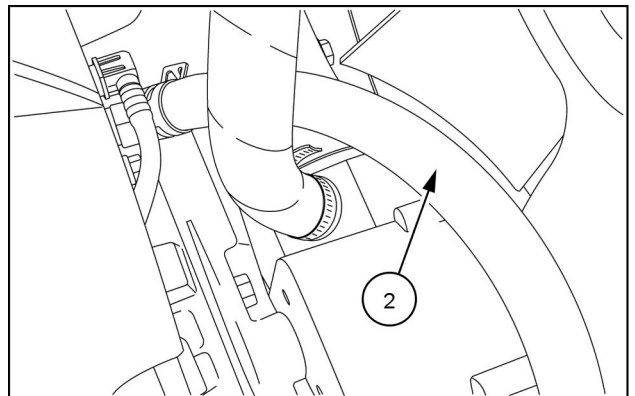

RAPH12WEL1476AA 10

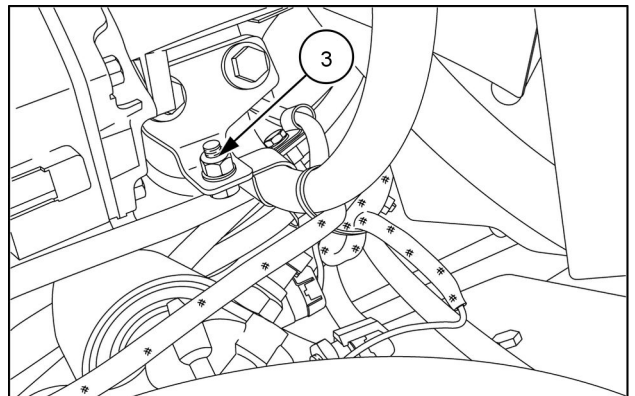

RAPH12WEL1477AA 11

14. Connect the engine coolant vent hose.

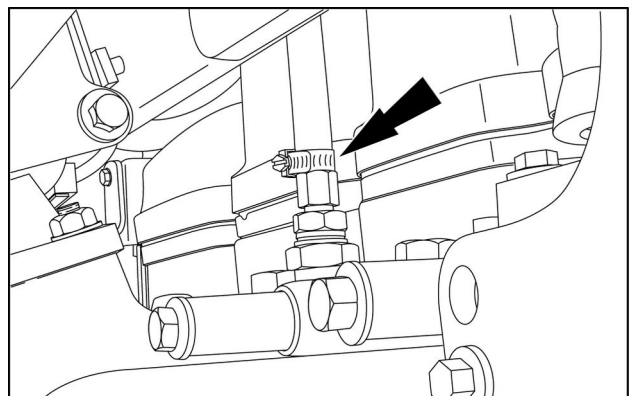

RAPH12WEL1491AA 12

15. Install the wires (2) to the starter solenoid. Refer to marked tag to ensure wires are installed correctly. Install the ground cable and the ground strap (3) to the starter. Install the starter mounting nuts (1). Tighten the mounting nuts to a torque of **40 - 50 N·m (30 - 37 lb ft)**.

**NOTE:** If the starter mounting studs (4) are replaced, apply **LOCTITE® 7471 PRIMER T™** to studs and holes. After primer has been applied, apply **LOCTITE® 271** to studs and holes. Tighten to torque of **19 - 29 N·m (14 - 21 lb ft)**.

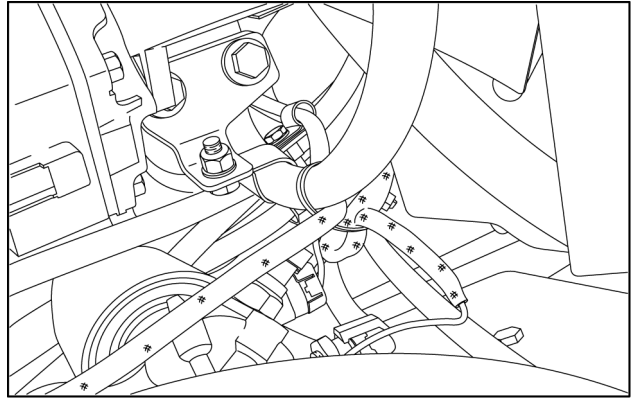

RAPH12WEL1477AA 13

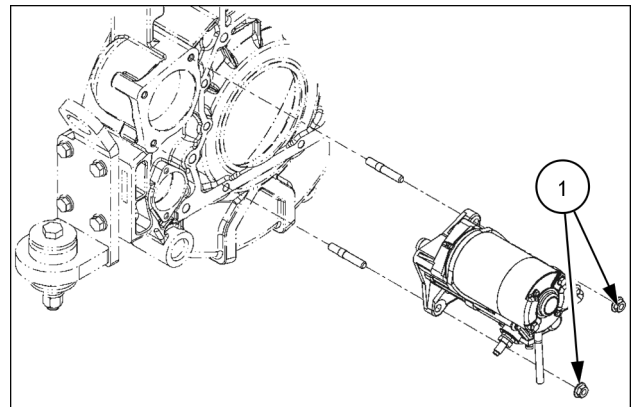

RAPH12WEL1514AA 14

16. Install bolt securing wiring harness clamp (1) to the engine. Install ground wires (2) to the engine.

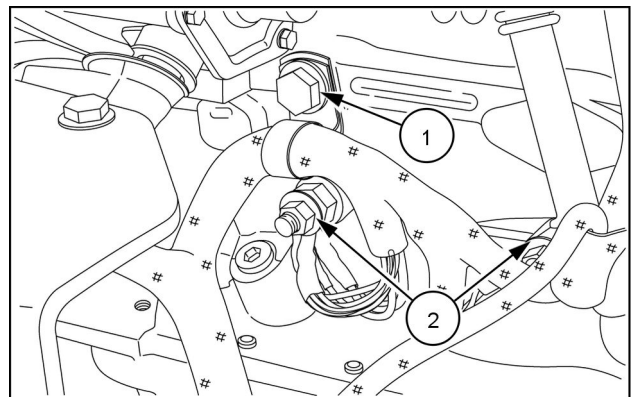

RAPH12WEL1475AA 15

17. Connect the wiring to the alternator. Refer to marked tag to ensure wires are installed correctly.

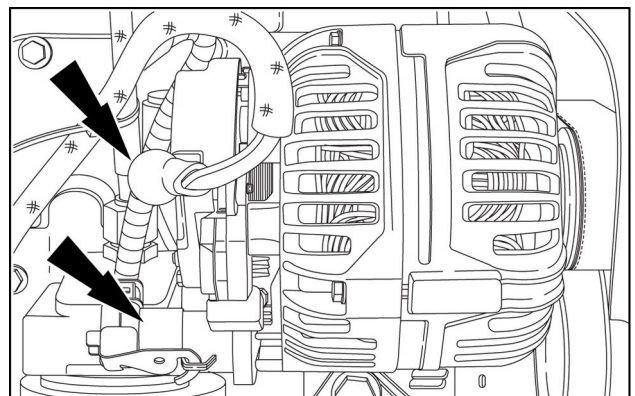

RAPH12WEL1468AA 16

18. If the machine is equipped with air conditioning, mount the compressor using the two mounting bolts (2). Connect the engine wiring harness connectors to the air compressor clutch connector (1). Refer to marked tag to ensure wires are installed correctly.

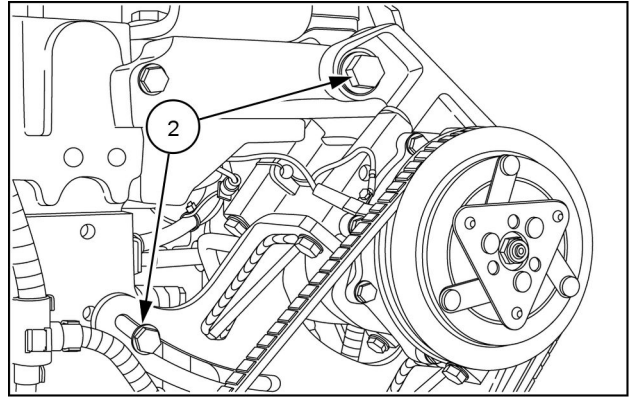

RAPH12WEL1472AA 17

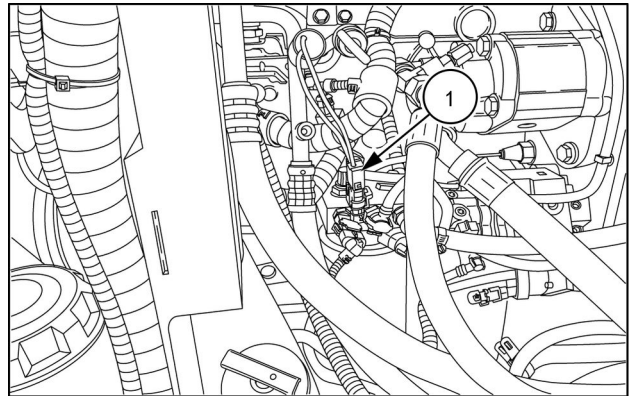

RAPH12WEL1505AA 18

19. Install the lower cooler hose to the engine. Tighten the clamps to a torque of **10.1 - 11.3 N·m (89 - 100 lb in)**.

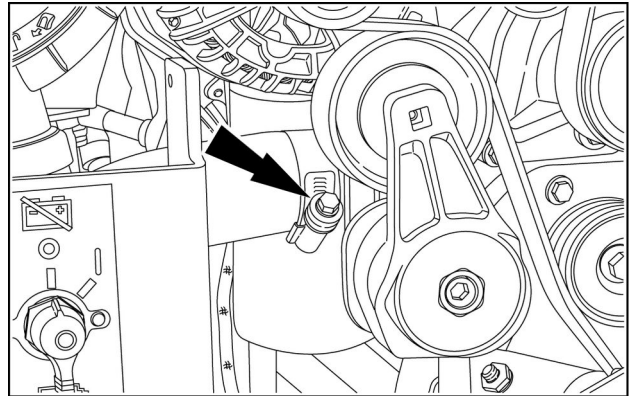

RAPH12WEL1470AA 19



**Suggest:**

**If the above button click is invalid.**

**Please download this document**

**first, and then click the above link**

**to download the complete manual.**

**Thank you so much for reading**

20. Install the drive belt (1) on the pulleys. If equipped with air conditioning, install air conditioning belt. Use the following air conditioning compressor belt tensions:

- For new belts, the tension is **45 kg (99 lb)**
- For belts with 20 or more service hours, the tension is **41 kg (90 lb)**

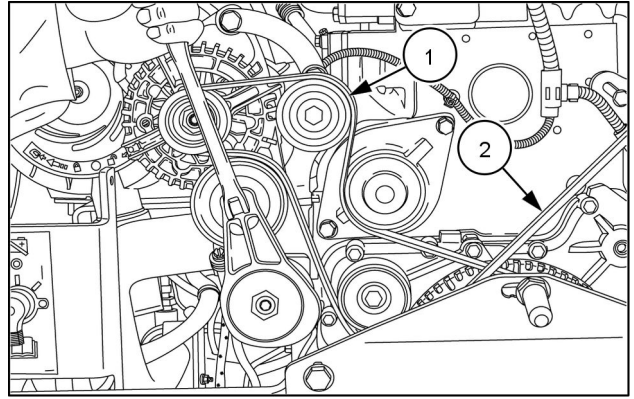

RAPH12WEL1469AA 20

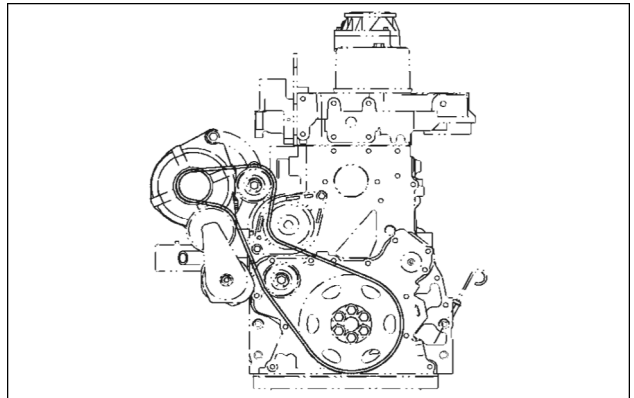

RAPH12WEL1517AA 21

21. Install the cover mounting brackets to the machine frame. Install the belt cover and secure with four mounting bolts.

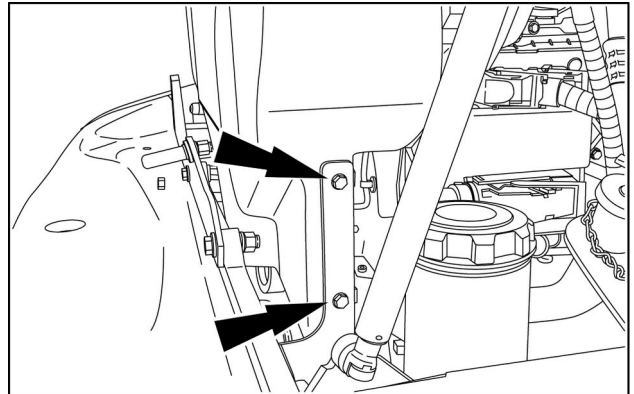

RAPH12WEL1492AA 22

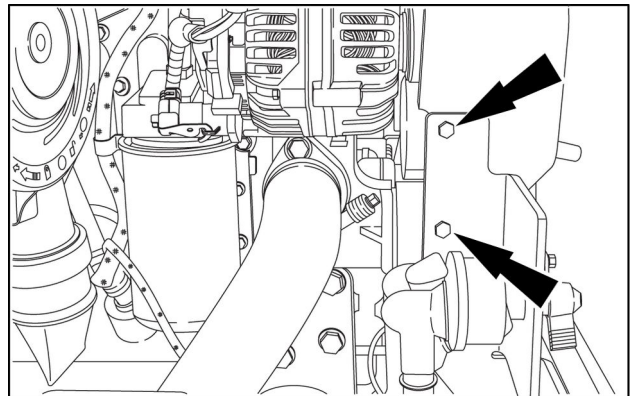

RAPH12WEL1467AA 23

**<https://www.ebooklibonline.com>**

Hello dear friend!

Thank you very much for reading.

Enter the link into your browser.

The full manual is available for immediate download.

**<https://www.ebooklibonline.com>**