

# 521E Wheel Loader Repair Manual 84186213 A - EU

## Table of Contents

Description	Section No.
<b>General</b> <span style="float: right;"><b>Tab 1</b></span>	
Section Index - General	
Standard Torque Specifications	1001
Fluids and Lubricants	1002
Metric Conversion Chart	1003
<b>Engines</b> <span style="float: right;"><b>Tab 2</b></span>	
Section Index - Engines	
Engine and Radiator Removal and Installation	2000
Stall Tests	2002
After Cooler	2003
For Engine Repair, See the Engine Service Manual 87630273	
<b>Fuel System</b> <span style="float: right;"><b>Tab 3</b></span>	
Section Index - Fuel System	
For Fuel System Repair, See the Engine Service Manual 87630273	
<b>Electrical</b> <span style="float: right;"><b>Tab 4</b></span>	
Section Index - Electrical	
Removal and Installation of Starter and Alternator	4001
Electrical Specifications and Troubleshooting	4002
Batteries	4003
Instrument Cluster	4005
<b>Steering</b> <span style="float: right;"><b>Tab 5</b></span>	
Section Index - Steering	
Removal and Installation of Steering Components	5001
Steering Specifications, Pressure Checks, and Troubleshooting	5002
Steering Cylinders	5005
Center Pivot	5006
Auxiliary Steering Motor and Pump	5008
Joystick Steering System (JSS) (option)	5009

# 521E Wheel Loader Repair Manual 84186213 A - EU

## Table of Contents

Description	Section No.
<b>Power Train</b>	<b>Tab 6</b>
Section Index - Power Train	
Removal and Installation of Power Train Components	6001
Transmission Specifications, Pressure Checks, and Troubleshooting	6002
Transmission	6003
Front Axle	6004
Rear Axle	6004
Drive Shafts, Center Bearing, and Universal Joints	6005
Wheels and Tires	6006
Transmission Control Valve	6007
<b>Brakes</b>	<b>Tab 7</b>
Section Index - Brakes	
Removal and Installation of Brake Components	7001
Hydraulic Brake Troubleshooting	7002
Brake Pump	7003
Brake Accumulators	7004
Parking Brake	7008
<b>Hydraulics</b>	<b>Tab 8</b>
Section Index - Hydraulics	
How to Read Hydraulic Schematics	8000
Removal and Installation of Hydraulic Components	8001
Hydraulic Specifications, Troubleshooting, and Pressure Checks	8002
Cleaning the Hydraulic System	8003
Loader Control Valve	8005
Cylinders	8006
Coupler Solenoid Locking Valve	8007
Ride Control Accumulator	8013
Ride Control Valve	8014

# 521E Wheel Loader Repair Manual 84186213 A - EU

## Table of Contents

Description	Section No.
<b>Mounted Equipment</b>	<b>Tab 9</b>
Section Index - Mounted Equipment	
Air Conditioning Troubleshooting and System Checks	9002
Air Conditioner System Service	9003
Removal And Installation Of Air Conditioning And Heater Components	9004
Loader	9006
Roll Over Protective Structure (ROPS), Cab Structural Frame (CSF)	9007
Cab Glass Installation	9010
<b>Electrical Schematic Foldouts and Hydraulic Schematic Foldout</b>	<b>In Rear Pocket</b>

**<https://www.ebooklibonline.com>**

Hello dear friend!

Thank you very much for reading.

Enter the link into your browser.

The full manual is available for immediate download.

**<https://www.ebooklibonline.com>**

## SECTION INDEX

### GENERAL

Section Title	Section Number
Standard Torque Specifications . . . . .	1001
Fluids and Lubricants . . . . .	1002
Metric Conversion Chart . . . . .	1003

# Section 1001

## GENERAL TORQUE SPECIFICATIONS

## TABLE OF CONTENTS

TORQUE SPECIFICATIONS - DECIMAL HARDWARE .....	3
TORQUE SPECIFICATIONS - METRIC HARDWARE .....	4
TORQUE SPECIFICATIONS - STEEL HYDRAULIC FITTINGS .....	5
TORQUE SPECIFICATIONS - STEEL HYDRAULIC FITTINGS .....	6

## TORQUE SPECIFICATIONS - DECIMAL HARDWARE

Use the torques in this chart when special torques are not given. These torques apply to fasteners with both UNC and UNF threads as received from suppliers dry, or when lubricated with engine oil. Not applicable if special graphities, Molydisulfide greases, or other extreme pressure lubricants are used.

Grade 5 Bolts, Nuts, and Studs		
		
Size	Pound-Inches	Newton metres
1/4 inch	108 to 132	12 to 15
5/16 inch	204 to 252	23 to 28
3/8 inch	420 to 504	48 to 57
Size	Pound-Feet	Newton metres
7/16 inch	54 to 64	73 to 87
1/2 inch	80 to 96	109 to 130
9/16 inch	110 to 132	149 to 179
5/8 inch	150 to 180	203 to 244
3/4 inch	270 to 324	366 to 439
7/8 inch	400 to 480	542 to 651
1.0 inch	580 to 696	787 to 944
1-1/8 inch	800 to 880	1085 to 1193
1-1/4 inch	1120 to 1240	1519 to 1681
1-3/8 inch	1460 to 1680	1980 to 2278
1-1/2 inch	1940 to 2200	2631 to 2983

Grade 8 Bolts, Nuts, and Studs		
		
Size	Pound-Inches	Newton metres
1/4 inch	144 to 180	16 to 20
5/16 inch	288 to 348	33 to 39
3/8 inch	540 to 648	61 to 73
Size	Pound-Feet	Newton metres
7/16 inch	70 to 84	95 to 114
1/2 inch	110 to 132	149 to 179
9/16 inch	160 to 192	217 to 260
5/8 inch	220 to 264	298 to 358
3/4 inch	380 to 456	515 to 618
7/8 inch	600 to 720	814 to 976
1.0 inch	900 to 1080	1220 to 1465
1-1/8 inch	1280 to 1440	1736 to 1953
1-1/4 inch	1820 to 2000	2468 to 2712
1-3/8 inch	2380 to 2720	3227 to 3688
1-1/2 inch	3160 to 3560	4285 to 4827

**NOTE:** Use thick nuts with Grade 8 bolts.

## TORQUE SPECIFICATIONS - METRIC HARDWARE

Use the following torques when specifications are not given.

These values apply to fasteners with coarse threads as received from supplier, plated or unplated, or when lubricated with engine oil. These values do not apply if graphite or Molydisulfide grease or oil is used.

<b>Grade 8.8 Bolts, Nuts, and Studs</b>		
		
Size	Pound-Inches	Newton metres
M4	24 to 36	3 to 4
M5	60 to 72	7 to 8
M6	96 to 108	11 to 12
M8	228 to 276	26 to 31
M10	456 to 540	52 to 61
Size	Pound-Feet	Newton metres
M12	66 to 79	90 to 107
M14	106 to 127	144 to 172
M16	160 to 200	217 to 271
M20	320 to 380	434 to 515
M24	500 to 600	675 to 815
M30	920 to 1100	1250 to 1500
M36	1600 to 1950	2175 to 2600

<b>Grade 10.9 Bolts, Nuts, and Studs</b>		
		
Size	Pound-Inches	Newton metres
M4	36 to 48	4 to 5
M5	84 to 96	9 to 11
M6	132 to 156	15 to 18
M8	324 to 384	37 to 43
Size	Pound-Feet	Newton metres
M10	54 to 64	73 to 87
M12	93 to 112	125 to 150
M14	149 to 179	200 to 245
M16	230 to 280	310 to 380
M20	450 to 540	610 to 730
M24	780 to 940	1050 to 1275
M30	1470 to 1770	2000 to 2400
M36	2580 to 3090	3500 to 4200

### Grade 12.9 Bolts, Nuts, and Studs

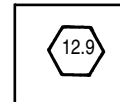

Usually the torque values specified for grade 10.9 fasteners can be used satisfactorily on grade 12.9 fasteners.

## TORQUE SPECIFICATIONS - STEEL HYDRAULIC FITTINGS

<b>37 Degree Flare Fitting</b>			
Tube OD Hose ID	Thread Size	Pound- Inches	Newton metres
1/4 inch 6.4 mm	7/16-20	72 to 144	8 to 16
5/16 inch 7.9 mm	1/2-20	96 to 192	11 to 22
3/8 inch 9.5 mm	9/16-18	120 to 300	14 to 34
1/2 inch 12.7 mm	3/4-16	180 to 504	20 to 57
5/8 inch 15.9 mm	7/8-14	300 to 696	34 to 79
Tube OD Hose ID	Thread Size	Pound- Feet	Newton metres
3/4 inch 19.0 mm	1-1/16-12	40 to 80	54 to 108
7/8 inch 22.2 mm	1-3/16-12	60 to 100	81 to 135
1.0 inch 25.4 mm	1-5/16-12	75 to 117	102 to 158
1-1/4 inch 31.8 mm	1-5/8-12	125 to 165	169 to 223
1-1/2 inch 38.1 mm	1-7/8-12	210 to 250	285 to 338

<b>Straight Threads with O-ring</b>			
Tube OD Hose ID	Thread Size	Pound- Inches	Newton metres
1/4 inch 6.4 mm	7/16-20	144 to 228	16 to 26
5/16 inch 7.9 mm	1/2-20	192 to 300	22 to 34
3/8 inch 9.5 mm	9/16-18	300 to 480	34 to 54
1/2 inch 12.7 mm	3/4-16	540 to 804	57 to 91
Tube OD Hose ID	Thread Size	Pound- Feet	Newton metres
5/8 inch 15.9 mm	7/8-14	58 to 92	79 to 124
3/4 inch 19.0 mm	1-1/16-12	80 to 128	108 to 174
7/8 inch 22.2 mm	1-3/16-12	100 to 160	136 to 216
1.0 inch 25.4 mm	1-5/16-12	117 to 187	159 to 253
1-1/4 inch 31.8 mm	1-5/8-12	165 to 264	224 to 357
1-1/2 inch 38.1 mm	1-7/8-12	250 to 400	339 to 542

<b>Split Flange Mounting Bolts</b>		
Size	Pound- Inches	Newton metres
5/16-18	180 to 240	20 to 27
3/8-16	240 to 300	27 to 34
7/16-14	420 to 540	47 to 61
Size	Pound- Feet	Newton metres
1/2-13	55 to 65	74 to 88
5/8-11	140 to 150	190 to 203

## MAINTENANCE POINTS Model 521E

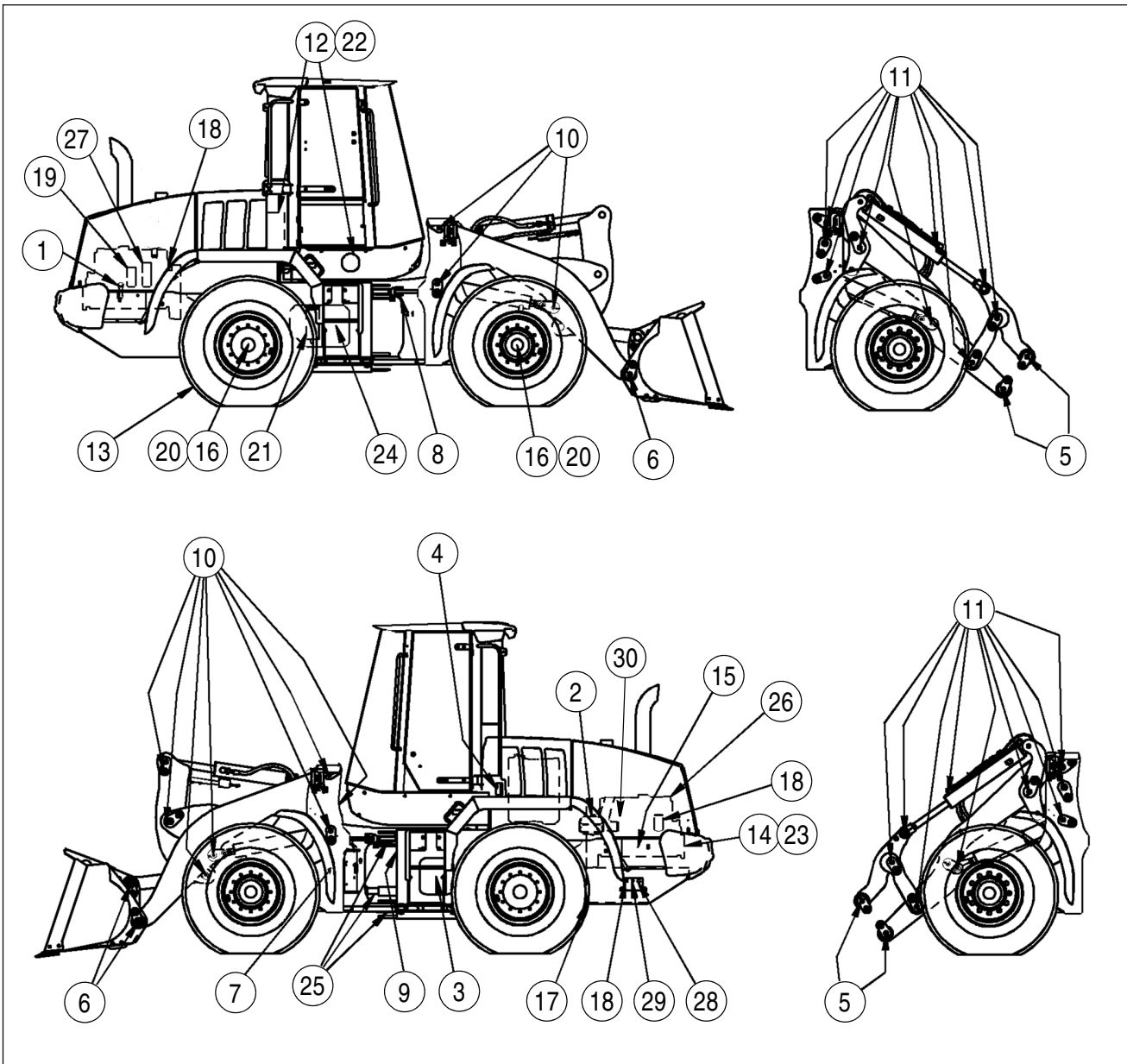

BS08B289

See your Operators manual for maintenance of safety related items and for detailed information of the service items on this chart. Operators and service manuals are available for this machine from your dealer.

If you operate the machine in severe conditions, lubricate and service the machine more frequently.

# Section 2000

## ENGINE AND RADIATOR REMOVAL AND INSTALLATION

## ENGINE

### Removal

#### STEP 1

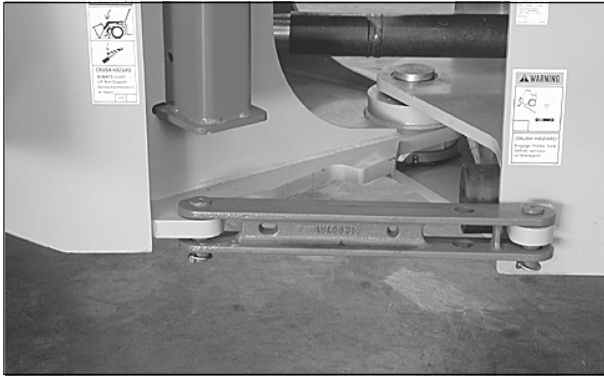

BD03A040

Park machine on a level surface and lower bucket to ground. Put articulation lock in LOCKED position.

#### STEP 2

Stop engine. Actuate brake pedal several times to discharge brake accumulators. Put key switch in ON position and move loader control lever back and forth at least 30 times to release any pressure from hydraulic circuit. Put key switch in OFF position.

#### STEP 3

Slowly loosen the filler cap for hydraulic reservoir to release air pressure in hydraulic reservoir.

#### STEP 4

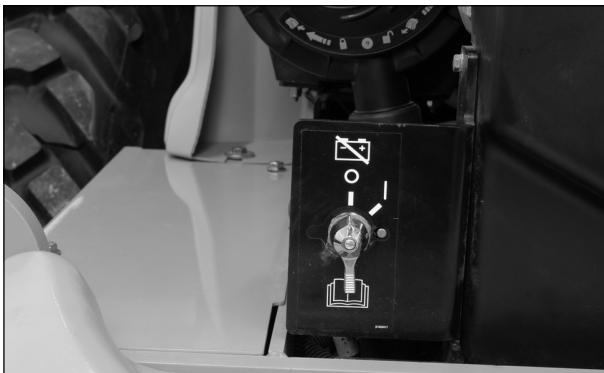

BD07N563-01

The master disconnect is located under the hood on the left rear side of the machine. Raise the hood put master disconnect switch in OFF position. Remove both battery covers and disconnect batteries from the machine.

#### STEP 5

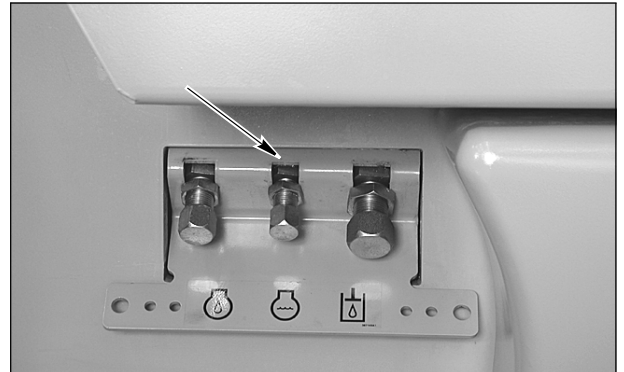

BD02N160

Put a container capable of holding at least 22.7 liter (6.0 gallon) below radiator drain. Remove radiator cap. Remove cap and drain coolant into container. Install cap after coolant has drained. Install radiator cap.

#### STEP 6

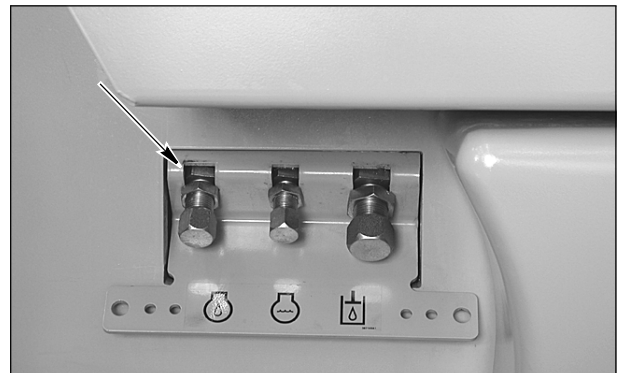

BD02N160

Put a container capable of holding at least 12.3 liter (13 U.S. quarts) below engine oil drain. Remove cap and drain oil into container. Install cap after oil has drained.

**NOTE:** After draining oil disconnect drain hose from frame for removal with engine.

**STEP 7**

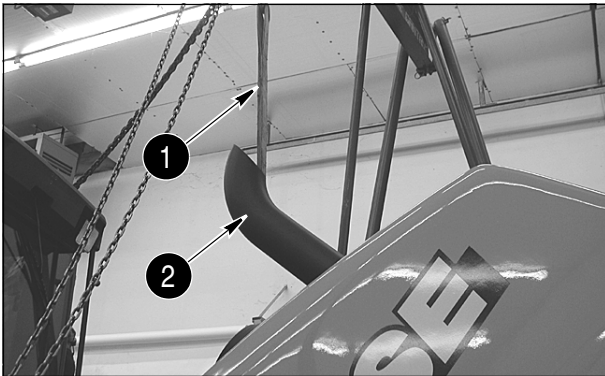

BD03A231

Double up a nylon lifting strap (1) and slide through the exhaust stack (2) on the hood.

**STEP 8**

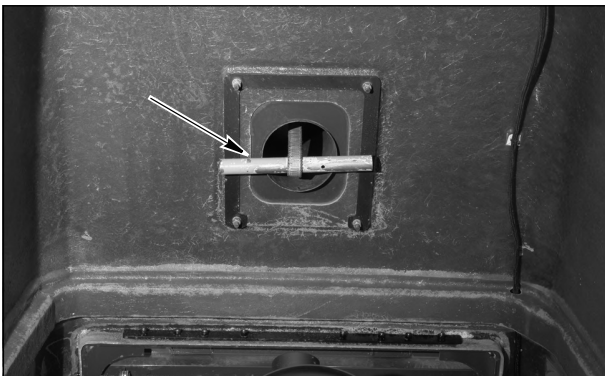

BD07N564-01

Place a solid steel bar through the strap, raise the hood and release tension on the lifting motor.

**STEP 9**

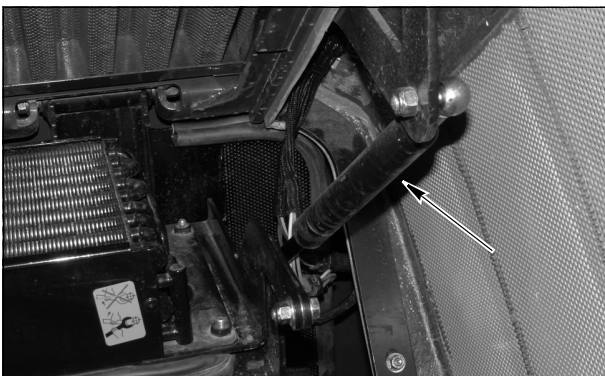

BD07N597-01

Remove the right front lift cylinder from the hood. Repeat the procedure for the left hand side.

**STEP 10**



BD07N566-01

Remove the rear lift cylinder from the machine.

**STEP 11**

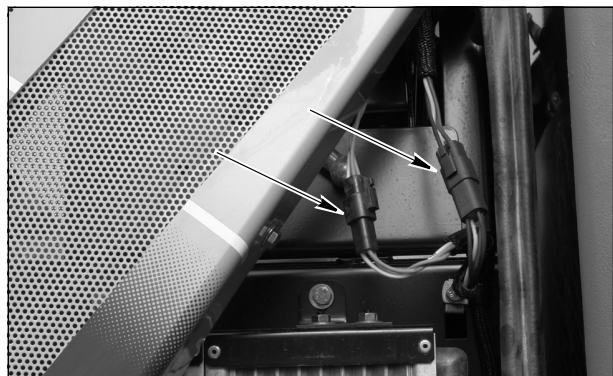

BD07N566-01

Tag and disconnect hood wiring harness connector and backup alarm connector from rear chassis wiring harness connector.

**STEP 12**

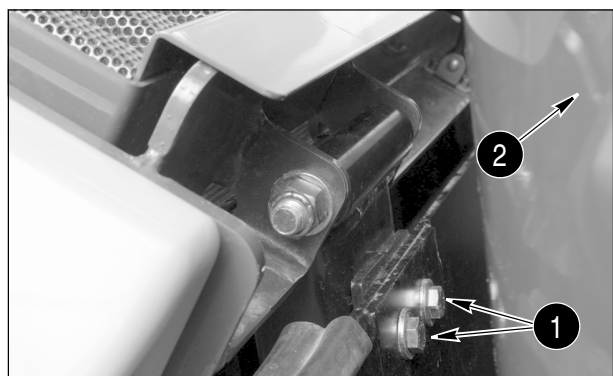

BD07N567-01

Have another person balance the hood, and remove the hood hinge mounting bolts (1) located outside the hood by the cab (2) from the cooler frame. Repeat procedure for the other side.

**STEP 13**



BD03A232

Carefully raise and remove hood from loader. Lower hood onto suitable platform and disconnect lifting equipment.

**STEP 14**



BD07N568-01

Tag and disconnect engine wiring harness connector from air filter restriction switch.

**STEP 15**



BD07N569-01

Loosen clamp on air cleaner intake hose and remove the crankcase ventilation hose.

**STEP 16**

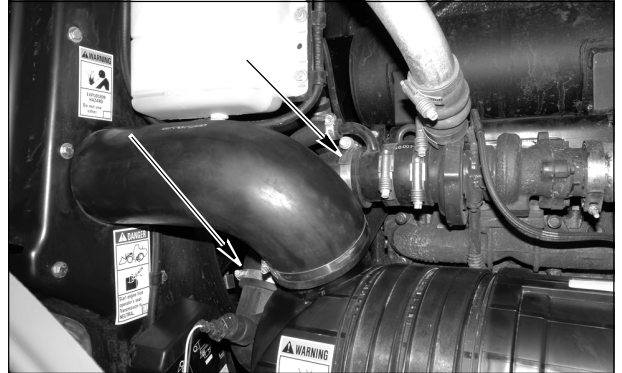

BD07N569-01

Loosen clamps on turbocharger and air cleaner, remove the intake hose.

**STEP 17**

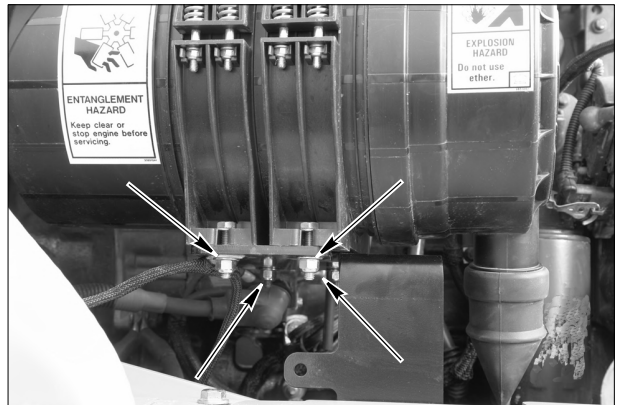

BD07N590-01

Remove the air cleaner by removing the four bolts.

**STEP 18**



BD07N569-01

Loosen the clamp on the turbocharger for the after cooler inlet hose.

2000-6

### STEP 19



BD07N565-01

Loosen the clamp on the after cooler and remove the after cooler inlet hose from the machine.

### STEP 20

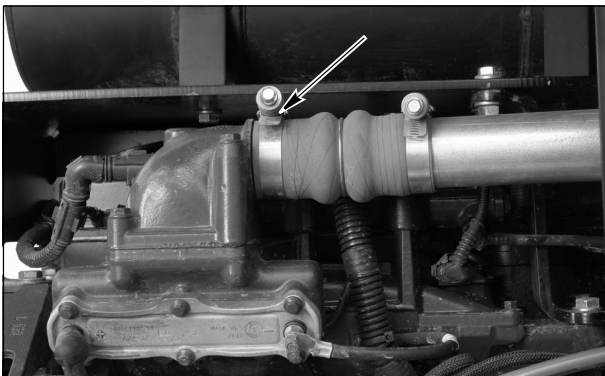

BD07N570-01

Loosen the clamp on the intake manifold for the after cooler output hose.

### STEP 21



BD07N571-01

Loosen the clamp on the after cooler and remove the after cooler outlet hose from the machine.

### STEP 22

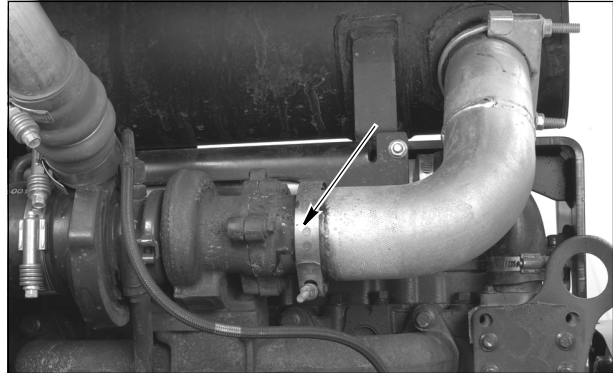

BD07N572-01

Loosen the exhaust clamp from the turbocharger.

### STEP 23

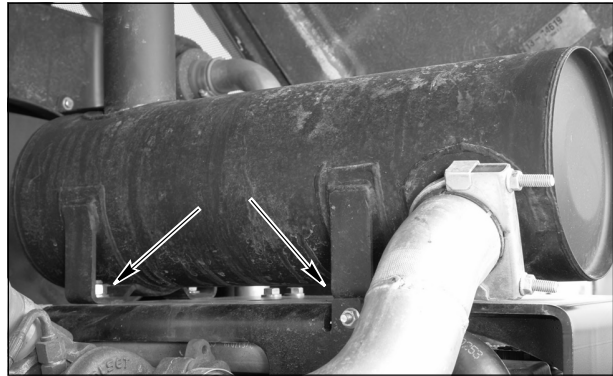

BD07N592-01

Remove the muffler from the bracket.

**STEP 24**

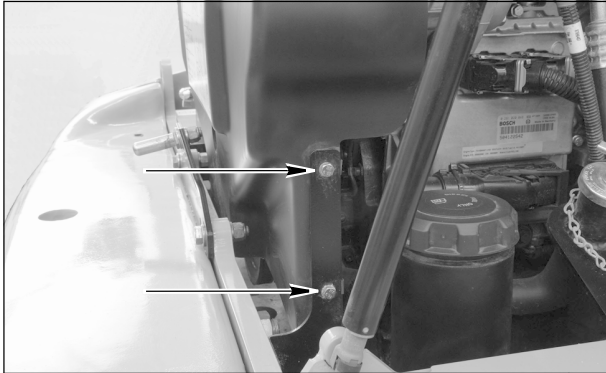

BD07N600-01

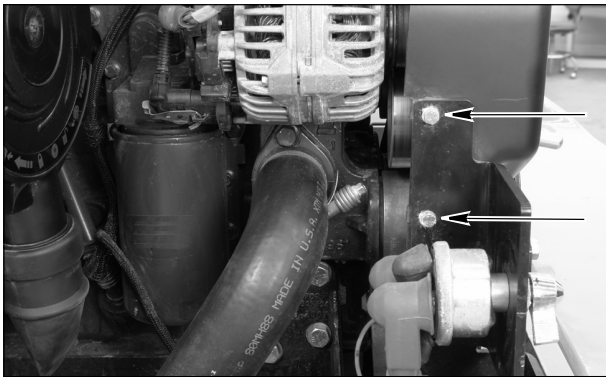

BD07N573-01

Remove the four mounting bolts from the belt cover, remove the cover.

**NOTE:** After removing the belt cover remove the cover mounting brackets from the machine frame.

**STEP 25**



BD07N576-01

Remove the drive belt from the engine.

**STEP 26**

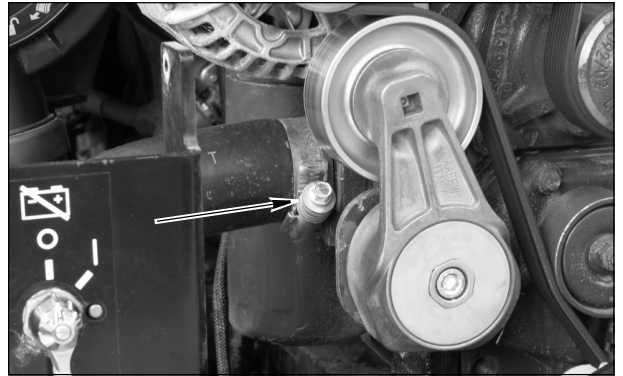

BD07N577-01

Loosen clamps and remove lower cooler hose from the engine.

**STEP 27**

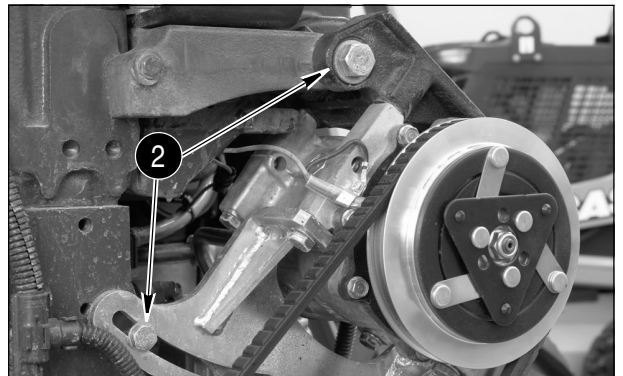

BD07N579-01

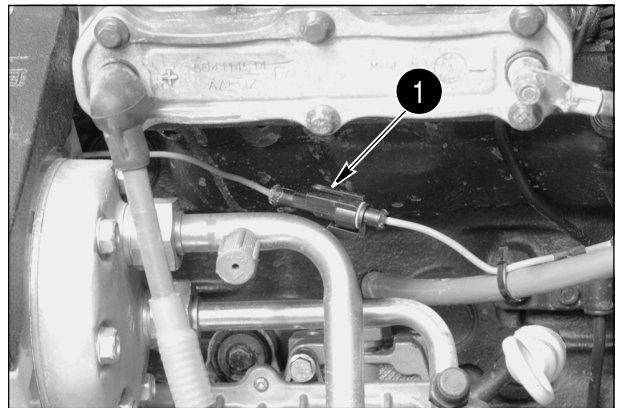

BD07N578-01

If loader is equipped with air conditioning, identify, tag, and disconnect the engine wiring harness connectors from air compressor clutch connector (1). Remove the two mounting bolts (2) for the compressor and set the compressor on the left battery cover.

2000-8

### STEP 28

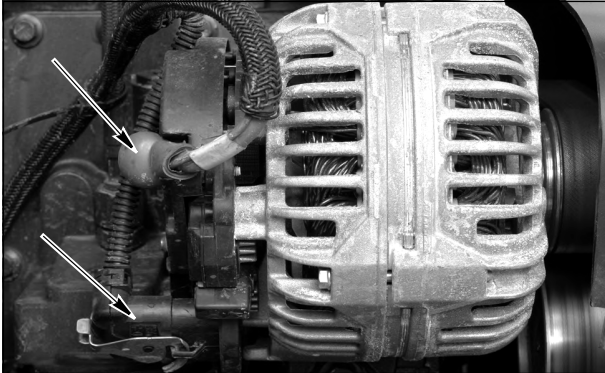

BD07N575-01

Tag and disconnect the wiring from the alternator.

### STEP 29

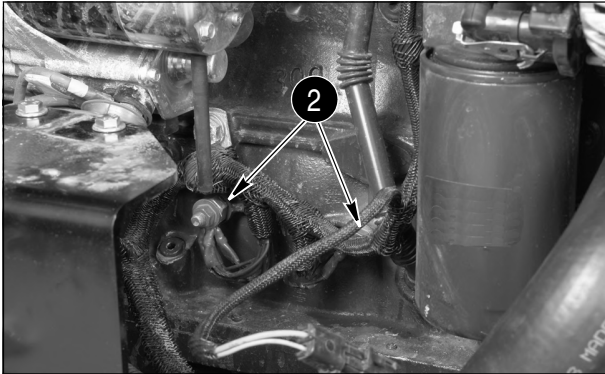

BD07N580-01

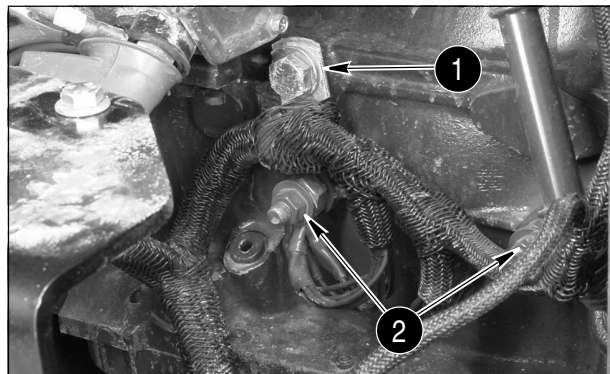

BD07N582-01

Remove bolt securing wiring harness clamp (1) to the engine. Remove ground wires (2) from the engine.

### STEP 30

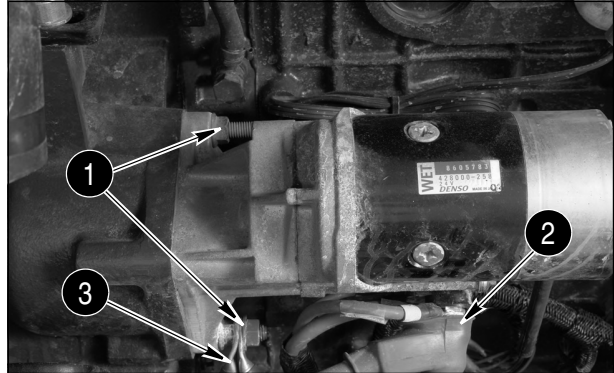

BD07N581-01

Tag and remove the wires from the starter solenoid (2), remove the ground cable and ground strap (3) from the starter. Then remove the two mounting bolts (1).

**NOTE:** Move the starter cables away from the engine, move the wiring harness away from the engine.

### STEP 31

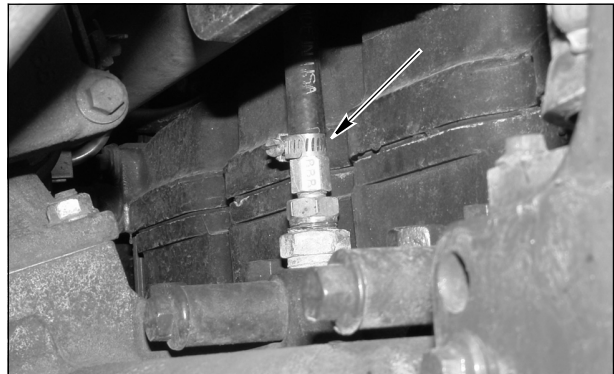

BD07N599-01

Disconnect the engine coolant vent hose and route to the rear of the engine.

**STEP 32**

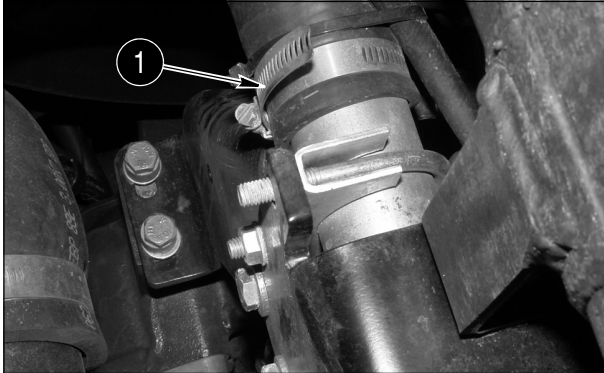

BD07N596-01

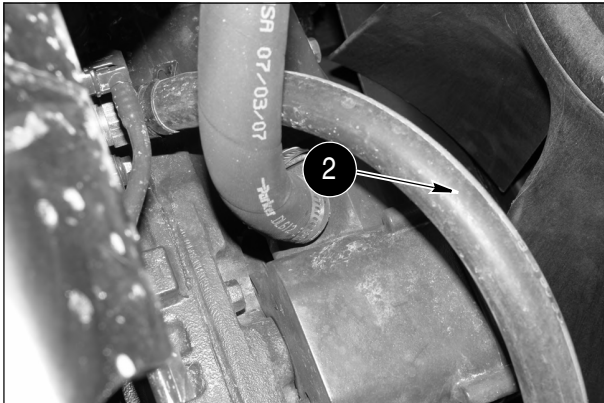

BD07N583-01

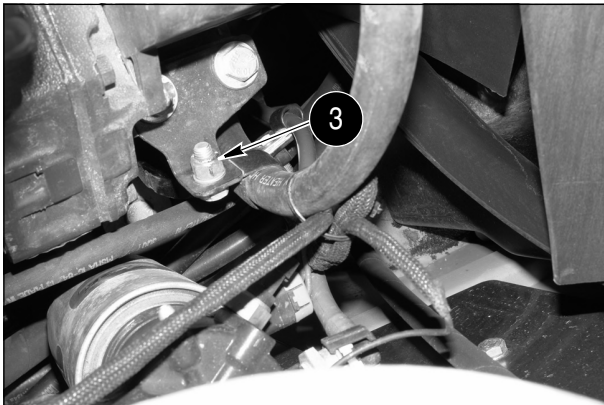

BD07N584-01

Remove the radiator hose (1) from the rear of the engine, remove the heater hose from the rear of the engine (2), remove the clamp bolts and clamps (3) from the bell housing.

**STEP 33**

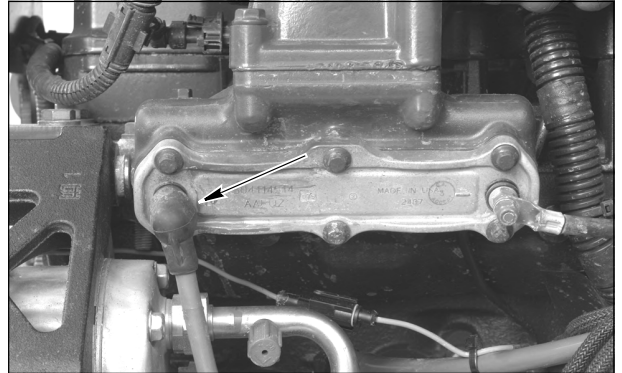

BD07N585-01

Tag and remove the grid heater cable.

**STEP 34**



BD07N586-01

Disconnect the wiring harness from the EDC 7 controller.

**NOTE:** *Lifting up on the lever will release the connector from the controller.*

**STEP 35**



BD07N591-01

Remove the fuel line from the top of the EDC 7 controller, plug the line and cap the fitting.

**STEP 36**

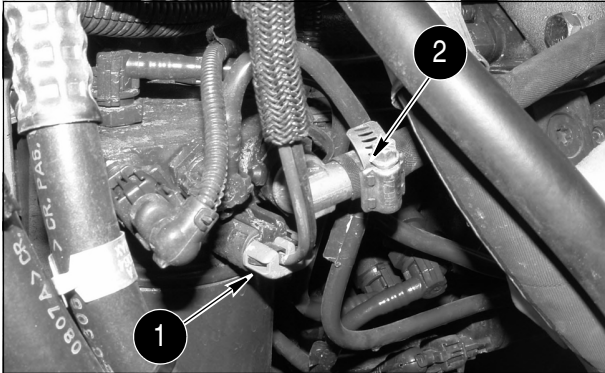

BD07N598-01

Tag and disconnect the fuel filter heater wires (1), disconnect the fuel line (2) from the fuel filter head, plug the line and cap the fitting.

**STEP 37**



BD07N588-01

Connect and turn on vacuum pump to hydraulic reservoir. Tag and remove the hydraulic lines from the brake system pump, plug the lines and cap the fittings.

**STEP 38**

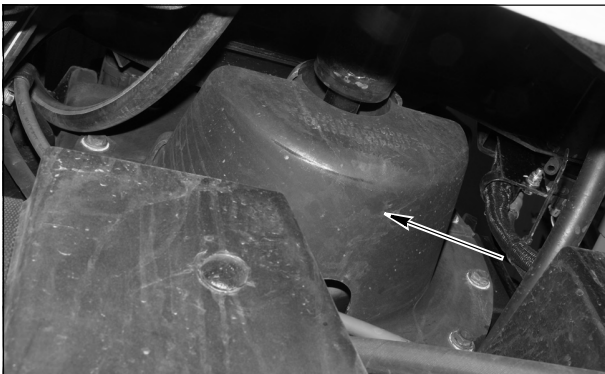

BD07N589-01

Remove the lower cover for the drive shaft.

**STEP 39**

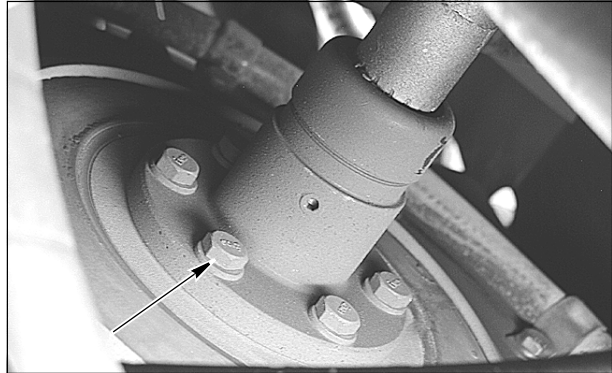

BD03A172

Remove the drive shaft bolts from the flywheel. Move the drive shaft clear of the flywheel.

**STEP 40**

Connect suitable lifting equipment to engine lifting brackets. Take up all slack in lifting equipment. Remove the engine mounting bolts and lift the engine enough to gain access to the drain hose, pull the engine oil drain hose with the engine.

**STEP 41**

Slowly raise engine from rear chassis. Be sure all harness connections and hoses have been disconnected and are clear of the engine. Remove engine from machine.

## Installation

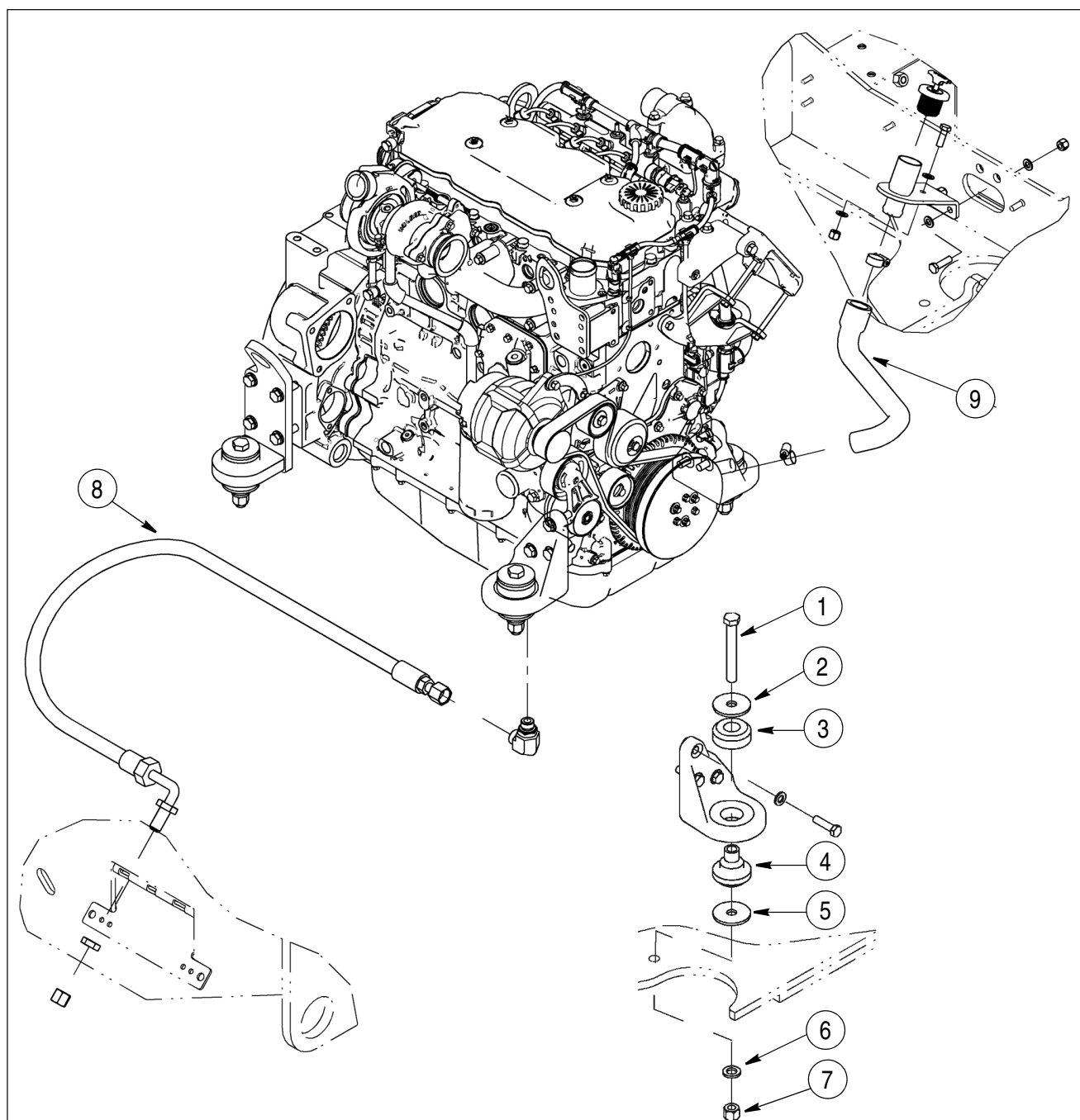

BS08A031

- |                      |                    |           |                          |                  |
|----------------------|--------------------|-----------|--------------------------|------------------|
| 1. ENGINE MOUNT BOLT | 3. INSULATOR UPPER | 5. WASHER | 7. NUT                   | 9. OIL FILL TUBE |
| 2. WASHER            | 4. INSULATOR LOWER | 6. WASHER | 8. REMOTE OIL DRAIN HOSE |                  |

### STEP 42

If engine rubber isolators require replacement, remove and discard isolators (3 and 4). Install new rubber isolator (4), then rubber isolator (3).

### STEP 43

Slowly raise engine and move into position over rear chassis. Be sure all harness connections and hoses are out of the way then lower engine. Put washer (5) between front rubber isolator (4) and chassis. Install washer (2), bolt (1), washer (6), and nut (7) in engine isolators. Lower engine into position.

2000-12

### STEP 44

Tighten engine mounting bolts to a torque of 244 to 298 Nm (180 to 220 lb-ft).

### STEP 45

Disconnect lifting equipment from engine lifting brackets.

### STEP 46

Connect engine oil drain hose to frame bracket.

### STEP 47

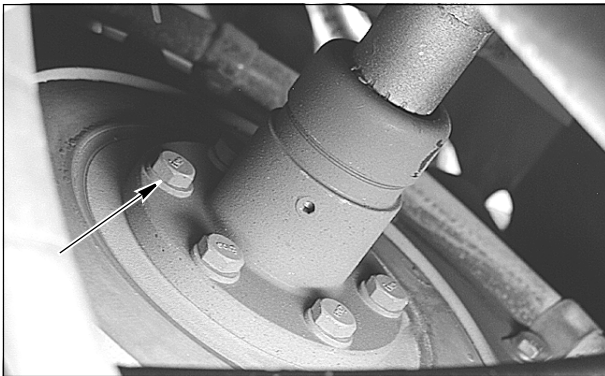

At front of engine, position drive shaft on engine coupling. Install six bolts to secure drive shaft to engine coupling. Apply Loctite 242 to threads and tighten the six bolts to a torque of 53 to 62 Nm (39 to 46 lb-ft).

### STEP 48



Install the lower cover for the drive shaft.

### STEP 49

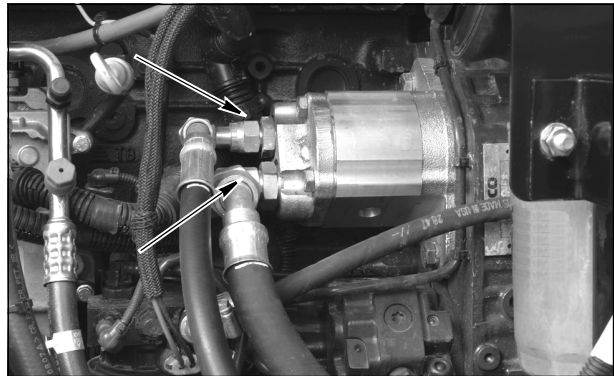

Connect and turn on vacuum pump to the hydraulic reservoir. Remove caps from fittings and plugs from hoses. Connect hoses to brake pump following tags installed during removal. Remove and discard tags. Turn off and disconnect vacuum pump from hydraulic reservoir.

### STEP 50

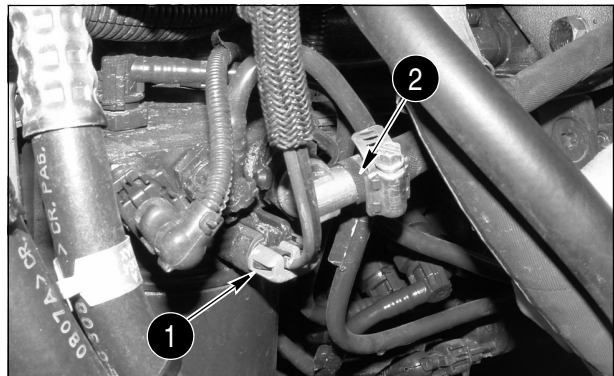

Remove cap from fitting and plug from the hose, connect fuel line (2). Connect fuel filter heater wires (1). Remove and discard tag.

### STEP 51



Remove cap from fitting and plug from the hose, connect fuel line to EDC 7.

**STEP 52**



BD07N586-01

Connect wiring harness to EDC 7 controller.

**NOTE:** Start the connector on the EDC 7 with lever straight out from EDC 7. Use lever to pull connector into position.

**STEP 53**

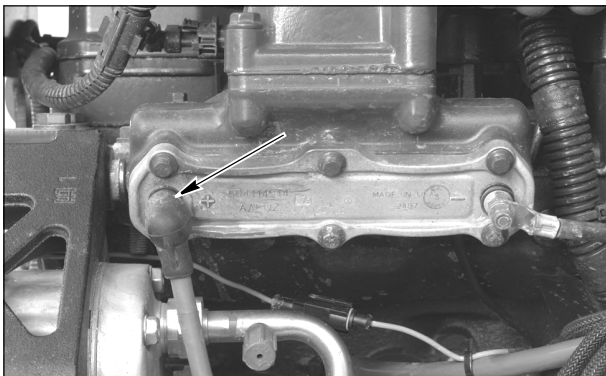

BD07N585-01

Connect grid heater cable to grid heater. Remove and discard tag.

**STEP 54**

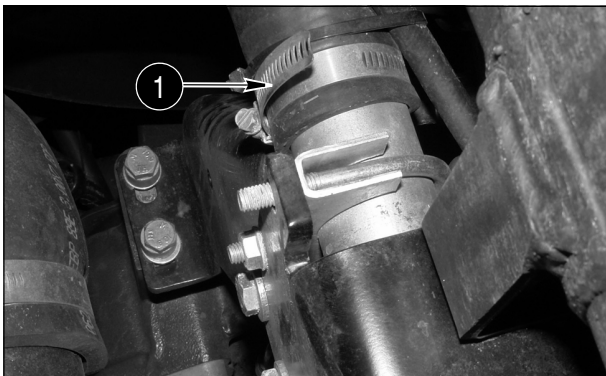

BD07N596-01

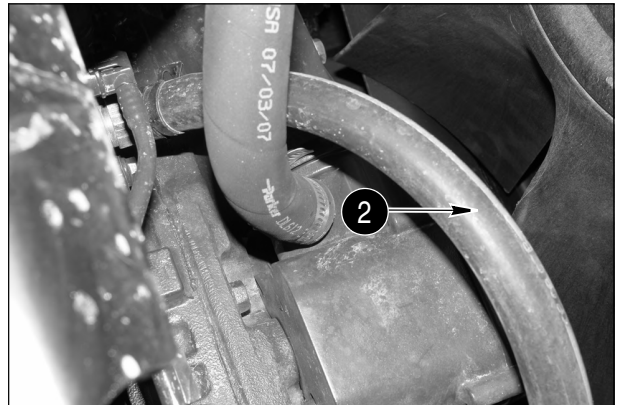

BD07N583-01

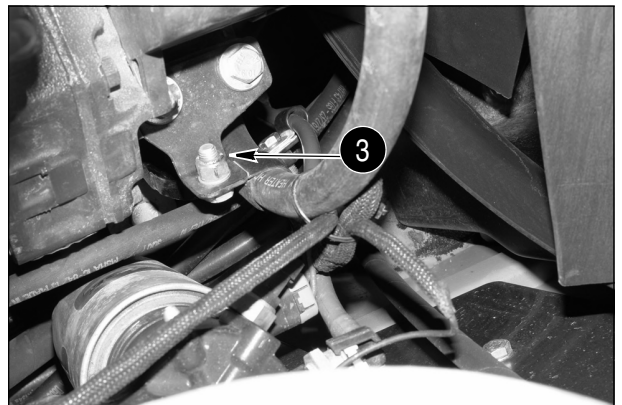

BD07N584-01

Install the heater hose (2) to the rear of the engine, mount the clamps (3), install the radiator hose (1).

**STEP 55**

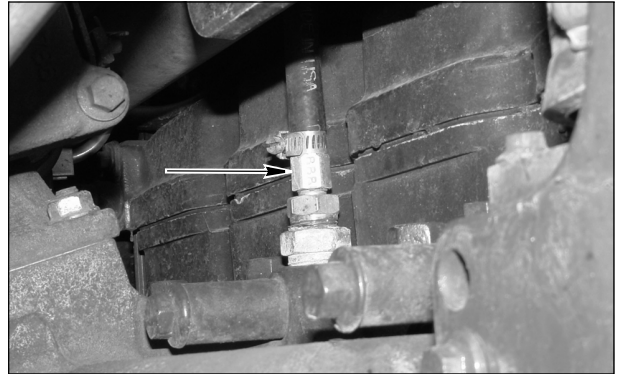

BD07N599-01

Connect the engine coolant vent hose.

### STEP 56

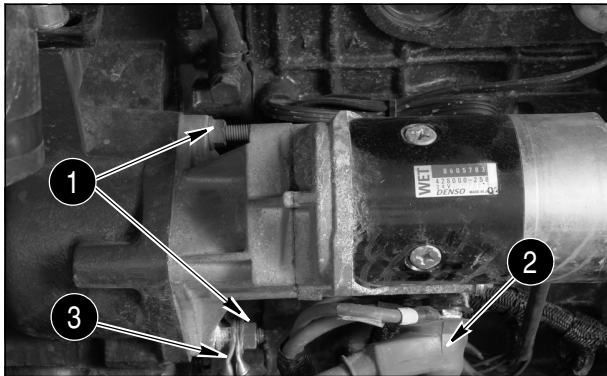

BD07N581-01

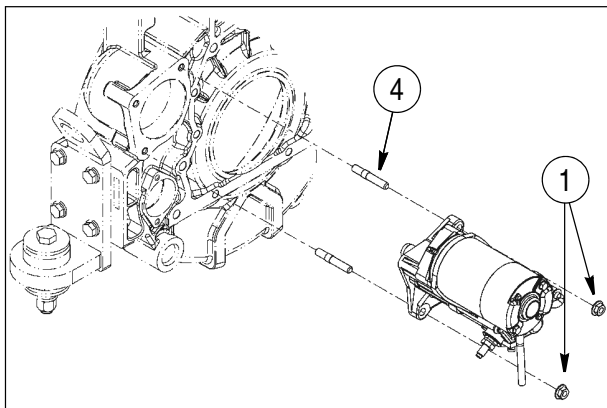

BS08A030

Install the wires (2) to the starter solenoid, install the ground cable and ground strap (3), to the starter. Torque starter mounting nuts (1) to 40 to 50 Nm (29 to 37 pound-feet). Remove and discard tags.

**NOTE:** If the starter mounting studs (4) have to be replaced apply Loctite 747 primer to studs and holes and apply Loctite 271 to each stud and hole and torque to 19 to 29 Nm (14 to 21 pound-feet).

### STEP 57

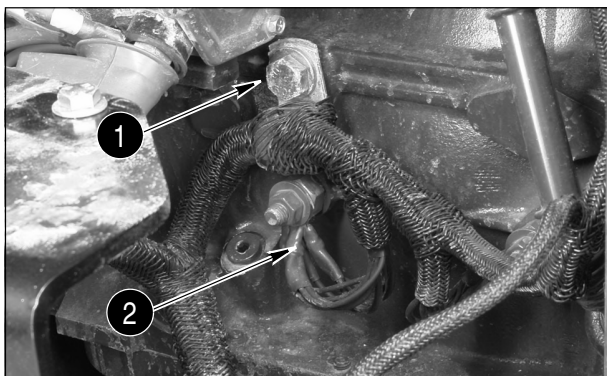

BD07N582-01

Install bolt securing wiring harness (1) clamp to the engine. Install ground wires (2) to the engine.

### STEP 58

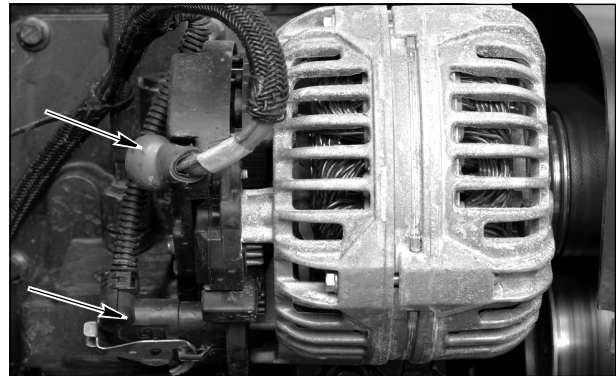

BD07N575-01

Connect the wiring to the alternator. Remove and discard tags.

### STEP 59

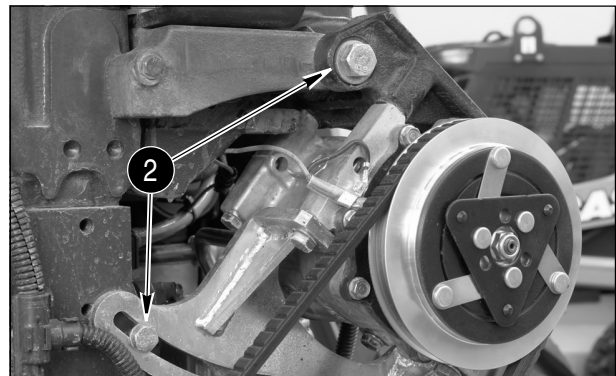

BD07N579-01

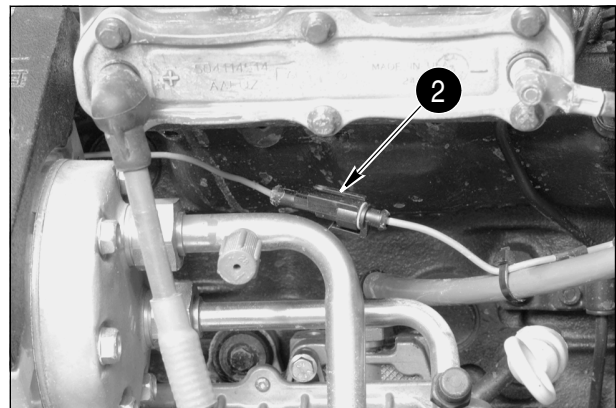

BD07N578-01

If loader is equipped with air conditioning, mount the compressor using the two mounting bolts (2), connect the engine wiring harness connectors to air compressor clutch connector (1). Remove and discard tags.

**STEP 60**

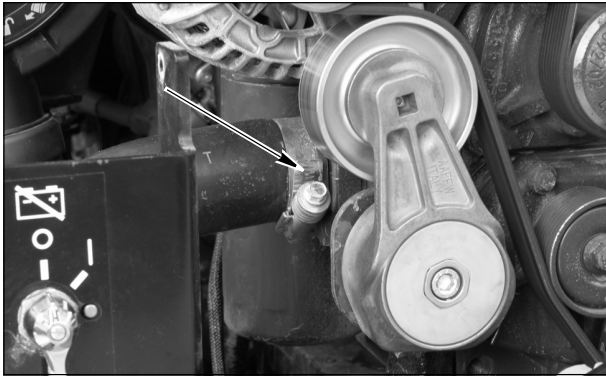

Install lower cooler hose to the engine and tighten the clamps to a torque of 10.1 to 11.3 Nm (90 to 100 lb-inch).

**STEP 61**

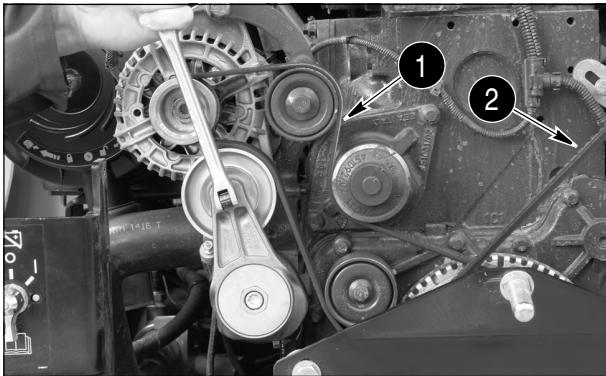

BD07N576-01

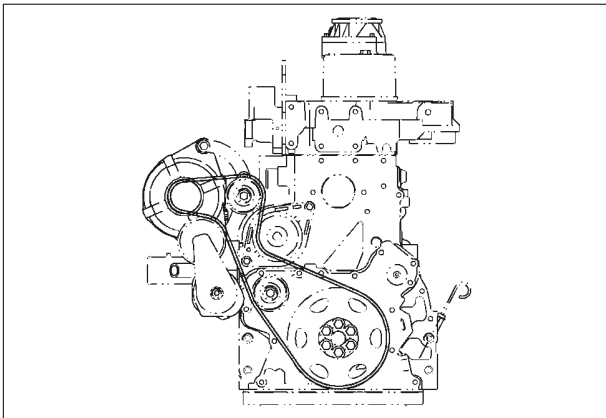

BS08A051

**DRIVE BELT ROUTING W/O AC (SEPARATE BELT FOR AC)**

Install the drive belt (1) on the pulleys. If equipped with air conditioning install belt (2).

**NOTE:** A/C compressor belt tension:

- A. Tension for a new belt is 45 Kg (100 lbs.).
- B. Tension for a belt used more than 20 hours is 41 Kg (90 lbs.).

**STEP 62**

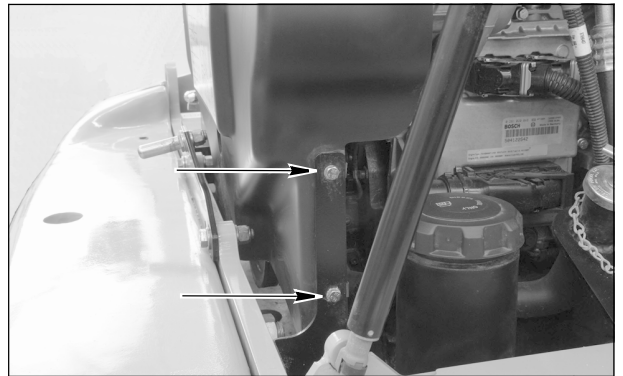

BD07N600-01

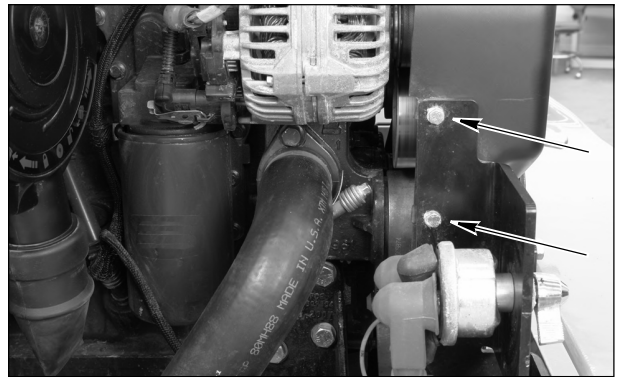

BD07N573-01

Install the cover mounting brackets to the machine frame. Install the belt cover, install the four mounting bolts for the belt cover.

**STEP 63**

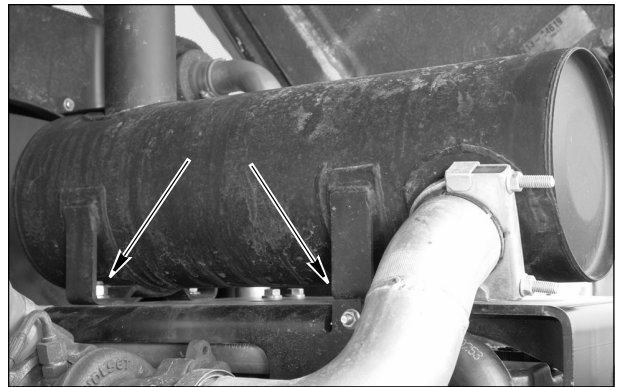

BD07N592-01

Place the muffler on the bracket. Install the mounting bolts in the muffler and leave loose at this time.



**Suggest:**

**If the above button click is invalid.**

**Please download this document**

**first, and then click the above link**

**to download the complete manual.**

**Thank you so much for reading**

2000-16

### STEP 64

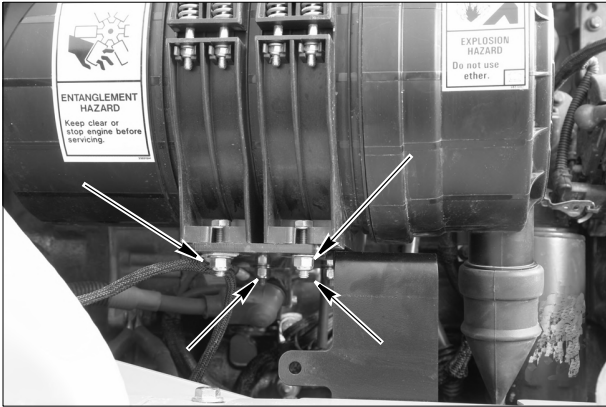

BD07N590-01

Place air cleaner on bracket. Install four mounting bolts in air cleaner and tighten.

### STEP 65

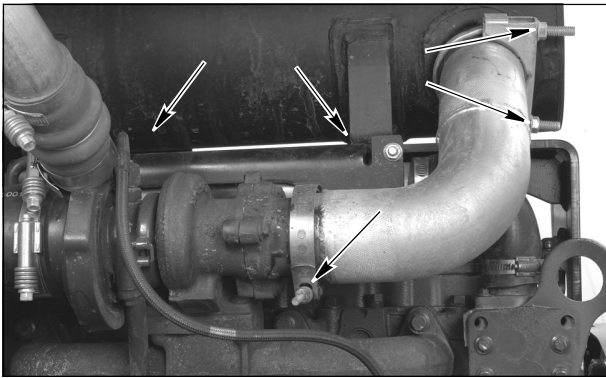

BD07N572-01

Install and tighten the exhaust clamp on the turbocharger, tighten the muffler mounting bolts.

### STEP 66



BD07N571-01

Place the after cooler outlet hose on the machine. Tighten the clamp on the after cooler.

### STEP 67

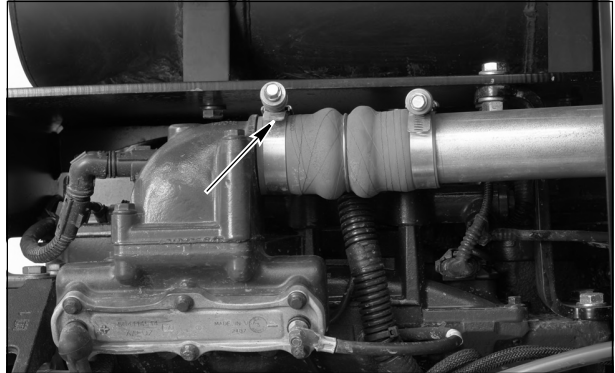

BD07N570-01

Tighten the clamp on the intake manifold for the after cooler output hose.

### STEP 68



BD07N565-01

Place the after cooler inlet hose on the machine. Tighten the clamp on the after cooler.

### STEP 69

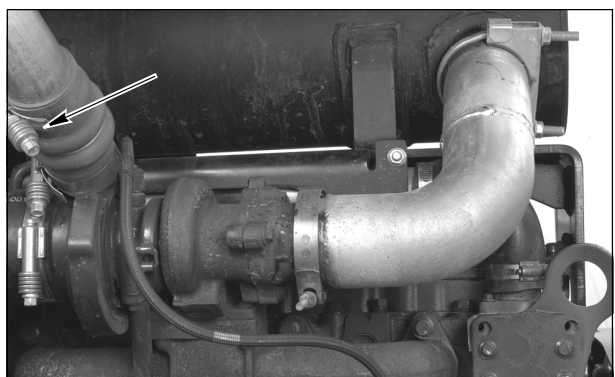

BD07N572-01

Tighten the clamp on the turbocharger for the after cooler inlet hose.

**<https://www.ebooklibonline.com>**

Hello dear friend!

Thank you very much for reading.

Enter the link into your browser.

The full manual is available for immediate download.

**<https://www.ebooklibonline.com>**