

521D Loader Service Manual 6-40745 Table of Contents

Description	Section No.	Form No.
General		
	Tab 1	
Section Index - General		6-42730
Standard Torque Specifications	1001	8-71603
Fluids and Lubricants	1002	6-40762
Metric Conversion Chart	1003	7-52950
Loctite Product Chart		8-98902
Engines		
	Tab 2	
Section Index - Engines		6-42281
Engine and Radiator Removal and Installation	2000	6-42290
Engine and Radiator Removal and Installation P.I.N. JEE0135501 and Above	2000	6-48920
Stall Tests	2002	6-40771
For Engine Repair, See the Engine Service Manual		6-74500
Fuel System		
	Tab 3	
Section Index - Fuel System		6-42300
For Fuel System Repair, See the Engine Service Manual		6-74500
Electrical		
	Tab 4	
Section Index - Electrical		6-42311
Removal and Installation of Starter and Alternator	4001	6-42321
Electrical Specifications and Troubleshooting	4002	6-40782
Electrical Specifications and Troubleshooting P.I.N. JEE0135501 and Above	4002	6-48930
Batteries	4003	6-42330
Information and Diagnostic Center	4005	6-42352
Alternator - 65 Ampere	4007	7-12260
Alternator - 45 Ampere	4008	6-42360

521D Loader Service Manual 6-40745 Table of Contents

Description	Section No.	Form No.
Steering Tab 5		
Section Index - Steering		6-42370
Removal and Installation of Steering Components	5001	6-42380
Steering Specifications, Pressure Checks, and Troubleshooting	5002	6-40790
Steering Control Valve	5003	6-42390
Steering Priority Valve	5004	6-42400
Steering Cylinders	5005	6-42410
Center Pivot	5006	6-42420
Auxiliary Steering Motor and Pump	5008	6-42430
Power Train Tab 6		
Section Index - Power Train		6-42442
Removal and Installation of Power Train Components	6001	6-42451
Transmission Specifications, Pressure Checks, and Troubleshooting	6002	6-40800
Transmission	6003	6-42460
Front and Rear Axle	6004	6-42470
Front and Rear Axle P.I.N. JEE0135501 and Above	6004	6-48970
Drive Shafts, Center Bearing, and Universal Joints	6005	6-42480
Wheels and Tires	6006	6-42490
Transmission Control Valve	6007	6-42500
Brakes Tab 7		
Section Index - Brakes		6-42510
Removal and Installation of Brake Components	7001	6-42521
Hydraulic Brake Troubleshooting	7002	6-40811
Brake Accumulators	7004	6-42531
Parking Brake	7008	6-42540
NOTE: For parking brake and brake pedal adjustments, see Section 9001.		
Hydraulics Tab 8		
Section Index - Hydraulics		6-42551
Removal and Installation of Hydraulic Components	8001	6-42562
Hydraulic Specifications, Troubleshooting, and Pressure Checks	8002	6-40822
Cleaning the Hydraulic System	8003	7-49640
Loader Control Valve	8005	6-42580
Cylinders	8006	6-42591
Coupler Solenoid Locking Valve	8007	6-42600
Pilot Pressure Accumulator and Ride Control Accumulator	8013	6-42621
Ride Control Valve	8014	6-44751

521D Loader Service Manual 6-40745 Table of Contents

Description	Section No.	Form No.
Mounted Equipment	Tab 9	
Section Index - Mounted Equipment		6-42640
Pedals and Levers	9001	6-40830
Air Conditioning Troubleshooting and System Checks For Systems with HFC-134a Refrigerant	9002	6-42650
Air Conditioner System Service	9003	6-42660
Removal and Installation of Air Conditioning Components For Systems with HFC-134a Refrigerant	9004	6-42671
Loader	9006	6-42691
ROPS Cab and ROPS Canopy	9007	6-42700
Cab Glass Installation	9010	6-42710
Electrical Schematic Foldouts and Hydraulic Schematic Foldout	In Rear Pocket	6-40841
Electrical Schematic Foldouts and Hydraulic Schematic Foldout P.I.N JEE0135501 and Above	In Rear Pocket	6-49280

NOTE: Case Corporation reserves the right to make improvements in design or changes in specifications at any time without incurring any obligation to install them on units previously sold.

<https://www.ebooklibonline.com>

Hello dear friend!

Thank you very much for reading.

Enter the link into your browser.

The full manual is available for immediate download.

<https://www.ebooklibonline.com>

SECTION INDEX

GENERAL

Section Title	Section Number
Standard Torque Specifications.....	1001
Fluids and Lubricants	1002
Metric Conversion Chart	1003
Loctite Product Chart	

CASE CORPORATION
700 State Street
Racine, WI 53404 U.S.A.

CASE CANADA CORPORATION
3350 South Service Road
Hamilton, ON L7N 3M6 CANADA

Bur 6-42730

Copyright © 2001 Case Corporation
Printed in U.S.A.
August, 2001

TORQUE SPECIFICATIONS - DECIMAL HARDWARE

Use the torques in this chart when special torques are not given. These torques apply to fasteners with both UNC and UNF threads as received from suppliers dry, or when lubricated with engine oil. Not applicable if special graphities, Molydisulfide greases, or other extreme pressure lubricants are used.

Grade 5 Bolts, Nuts, and Studs		
		
Size	Pound-Inches	Newton metres
1/4 inch	108 to 132	12 to 15
5/16 inch	204 to 252	23 to 28
3/8 inch	420 to 504	48 to 57
Size	Pound-Feet	Newton metres
7/16 inch	54 to 64	73 to 87
1/2 inch	80 to 96	109 to 130
9/16 inch	110 to 132	149 to 179
5/8 inch	150 to 180	203 to 244
3/4 inch	270 to 324	366 to 439
7/8 inch	400 to 480	542 to 651
1.0 inch	580 to 696	787 to 944
1-1/8 inch	800 to 880	1085 to 1193
1-1/4 inch	1120 to 1240	1519 to 1681
1-3/8 inch	1460 to 1680	1980 to 2278
1-1/2 inch	1940 to 2200	2631 to 2983

Grade 8 Bolts, Nuts, and Studs		
		
Size	Pound-Inches	Newton metres
1/4 inch	144 to 180	16 to 20
5/16 inch	288 to 348	33 to 39
3/8 inch	540 to 648	61 to 73
Size	Pound-Feet	Newton metres
7/16 inch	70 to 84	95 to 114
1/2 inch	110 to 132	149 to 179
9/16 inch	160 to 192	217 to 260
5/8 inch	220 to 264	298 to 358
3/4 inch	380 to 456	515 to 618
7/8 inch	600 to 720	814 to 976
1.0 inch	900 to 1080	1220 to 1465
1-1/8 inch	1280 to 1440	1736 to 1953
1-1/4 inch	1820 to 2000	2468 to 2712
1-3/8 inch	2380 to 2720	3227 to 3688
1-1/2 inch	3160 to 3560	4285 to 4827
NOTE: Use thick nuts with Grade 8 bolts.		

TORQUE SPECIFICATIONS - METRIC HARDWARE

Use the following torques when specifications are not given.

These values apply to fasteners with coarse threads as received from supplier, plated or unplated, or when lubricated with engine oil. These values do not apply if graphite or Molydisulfide grease or oil is used.

Grade 8.8 Bolts, Nuts, and Studs		
		
Size	Pound-Inches	Newton metres
M4	24 to 36	3 to 4
M5	60 to 72	7 to 8
M6	96 to 108	11 to 12
M8	228 to 276	26 to 31
M10	456 to 540	52 to 61
Size	Pound-Feet	Newton metres
M12	66 to 79	90 to 107
M14	106 to 127	144 to 172
M16	160 to 200	217 to 271
M20	320 to 380	434 to 515
M24	500 to 600	675 to 815
M30	920 to 1100	1250 to 1500
M36	1600 to 1950	2175 to 2600

Grade 10.9 Bolts, Nuts, and Studs		
		
Size	Pound-Inches	Newton metres
M4	36 to 48	4 to 5
M5	84 to 96	9 to 11
M6	132 to 156	15 to 18
M8	324 to 384	37 to 43
Size	Pound-Feet	Newton metres
M10	54 to 64	73 to 87
M12	93 to 112	125 to 150
M14	149 to 179	200 to 245
M16	230 to 280	310 to 380
M20	450 to 540	610 to 730
M24	780 to 940	1050 to 1275
M30	1470 to 1770	2000 to 2400
M36	2580 to 3090	3500 to 4200

Grade 12.9 Bolts, Nuts, and Studs

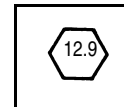

Usually the torque values specified for grade 10.9 fasteners can be used satisfactorily on grade 12.9 fasteners.

TORQUE SPECIFICATIONS - STEEL HYDRAULIC FITTINGS

Tube OD Hose ID	Thread Size	Pound- Inches	Newton metres
37 Degree Flare Fitting			
1/4 inch 6.4 mm	7/16-20	72 to 144	8 to 16
5/16 inch 7.9 mm	1/2-20	96 to 192	11 to 22
3/8 inch 9.5 mm	9/16-18	120 to 300	14 to 34
1/2 inch 12.7 mm	3/4-16	180 to 504	20 to 57
5/8 inch 15.9 mm	7/8-14	300 to 696	34 to 79
Tube OD Hose ID	Thread Size	Pound- Feet	Newton metres
3/4 inch 19.0 mm	1-1/16-12	40 to 80	54 to 108
7/8 inch 22.2 mm	1-3/16-12	60 to 100	81 to 135
1.0 inch 25.4 mm	1-5/16-12	75 to 117	102 to 158
1-1/4 inch 31.8 mm	1-5/8-12	125 to 165	169 to 223
1-1/2 inch 38.1 mm	1-7/8-12	210 to 250	285 to 338

Tube OD Hose ID	Thread Size	Pound- Inches	Newton metres
Straight Threads with O-ring			
1/4 inch 6.4 mm	7/16-20	144 to 228	16 to 26
5/16 inch 7.9 mm	1/2-20	192 to 300	22 to 34
3/8 inch 9.5 mm	9/16-18	300 to 480	34 to 54
1/2 inch 12.7 mm	3/4-16	540 to 804	57 to 91
Tube OD Hose ID	Thread Size	Pound- Feet	Newton metres
5/8 inch 15.9 mm	7/8-14	58 to 92	79 to 124
3/4 inch 19.0 mm	1-1/16-12	80 to 128	108 to 174
7/8 inch 22.2 mm	1-3/16-12	100 to 160	136 to 216
1.0 inch 25.4 mm	1-5/16-12	117 to 187	159 to 253
1-1/4 inch 31.8 mm	1-5/8-12	165 to 264	224 to 357
1-1/2 inch 38.1 mm	1-7/8-12	250 to 400	339 to 542

Split Flange Mounting Bolts		
Size	Pound- Inches	Newton metres
5/16-18	180 to 240	20 to 27
3/8-16	240 to 300	27 to 34
7/16-14	420 to 540	47 to 61
Size	Pound- Feet	Newton metres
1/2-13	55 to 65	74 to 88
5/8-11	140 to 150	190 to 203

Section 2000

ENGINE AND RADIATOR REMOVAL AND INSTALLATION

CASE CORPORATION
700 State Street
Racine, WI 53404 U.S.A.

CASE CANADA CORPORATION
3350 South Service Road
Burlington, ON L7N 3M6 CANADA

Bur 6-42290

Copyright © 2001 Case Corporation
Printed in U.S.A.
August, 2001

2000

ENGINE

Removal

STEP 1

Park machine on a level surface and lower bucket to floor. Stop engine. Actuate brake pedal several times to discharge brake accumulators. Put key switch in ON position and move loader control lever back and forth at least 30 times to release any pressure from hydraulic circuit. Put key switch in OFF position.

STEP 2



Put articulation lock in LOCKED position.

STEP 3

Slowly loosen the filler cap for hydraulic reservoir to release air pressure in hydraulic reservoir.

STEP 4

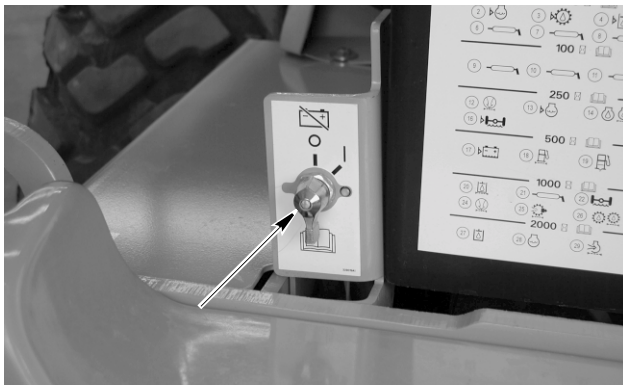

Open and raise hood. Put master disconnect switch in OFF position.

STEP 5

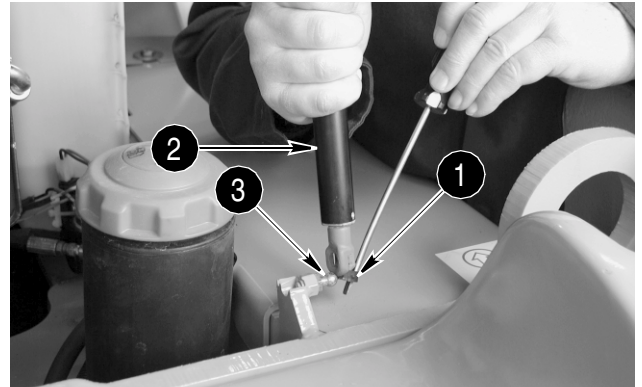

Using a flat blade screwdriver or other suitable tool, disengage bottom clip (1) from hood prop (2) and pull bottom of prop from stud (3). Repeat to remove top of prop from hood; remove prop then close hood.

STEP 6

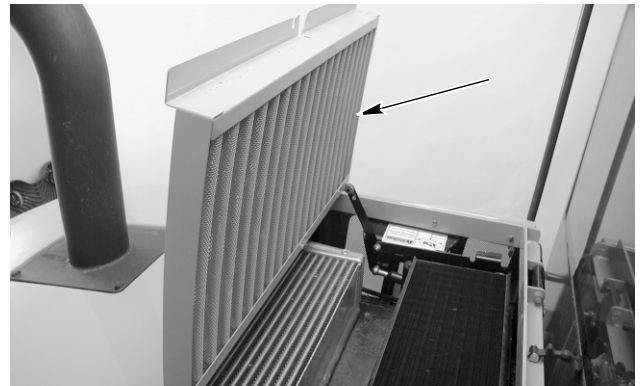

Open screen.

STEP 7



Remove cotter pin and three washers.

STEP 8

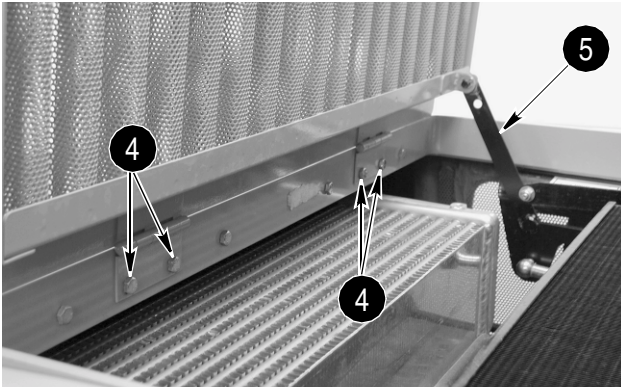

BD01D144

Remove four bolts (4) securing hinges of screen to hood. Disconnect prop bar (5) from screen and remove screen.

STEP 9

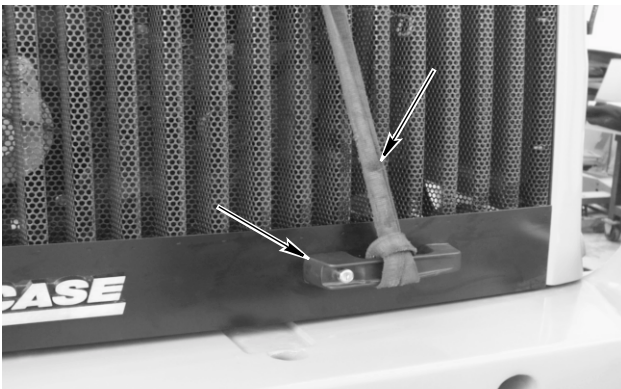

BD01D255

Connect a lifting strap to the hood handle and connect lifting equipment to strap. Depress handle latch and let hood raise.

STEP 10



BD01D256

Take up all slack in strap connected to hood handle.

STEP 11

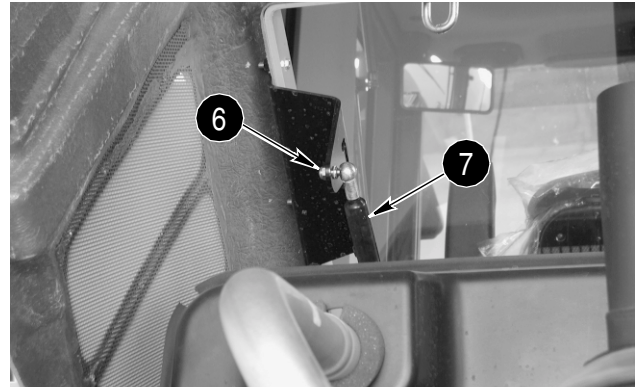

BD01D145

Remove lock nut (6) securing LH spring (7) to hood. Repeat to remove lock nut securing RH spring to hood. Disconnect springs from hood; it may be necessary to raise hood to disconnect springs from hood.

STEP 12



BD01D258

At front RH side of hood, identify, tag, and disconnect hood wiring harness connector from rear chassis wiring harness connector.

STEP 13

Lower hood.

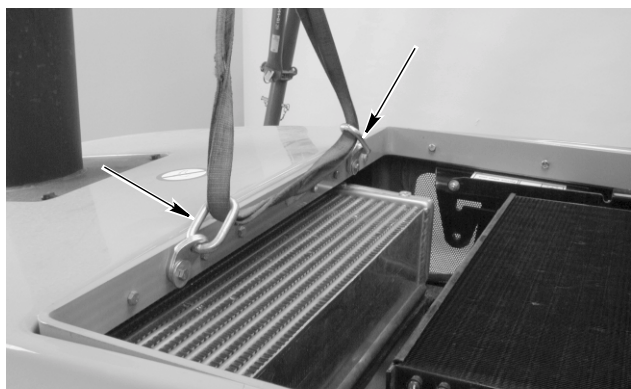
STEP 14

BD01D149

Install two lifting eyes and connect lifting strap to eyes.

STEP 15

BD01D254

Connect lifting equipment to the lifting straps.

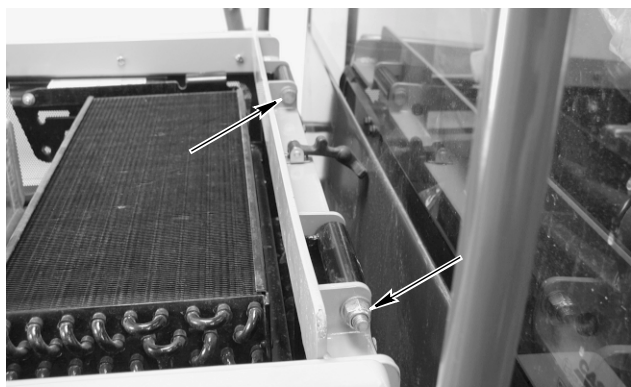
STEP 16

BD01D147

Remove two nuts and bolts and four washers securing hood.

STEP 17

BD01D254

Carefully raise and remove hood from loader. Lower hood onto suitable platform and disconnect lifting equipment.

STEP 18

BD01D150

Tag and disconnect engine wiring harness connector from air filter restriction switch.

STEP 19

BD01D152

Loosen clamp on air cleaner intake hose and remove hose.

STEP 20



BD01D154

Loosen clamp on turbocharger intake hose and disconnect hose from turbocharger.

STEP 21



BD01D155

Remove bolt and washer securing front of battery cover.

STEP 22



BD01D156

Loosen bolt. Slide battery cover forward and remove. Repeat Steps 21 and 22 to remove RH battery cover.

STEP 23

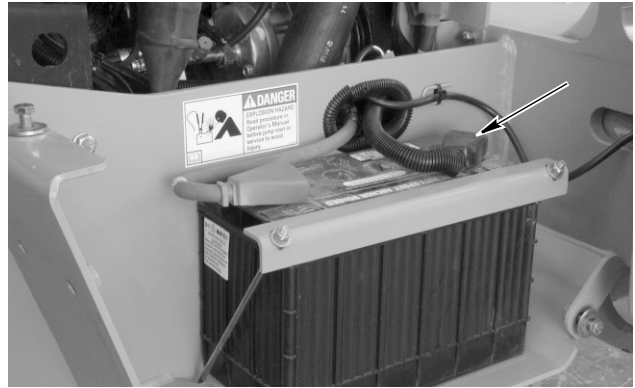

BD01D158

Disconnect battery cable from LH battery negative post. Put a plastic cap over the negative post.

STEP 24

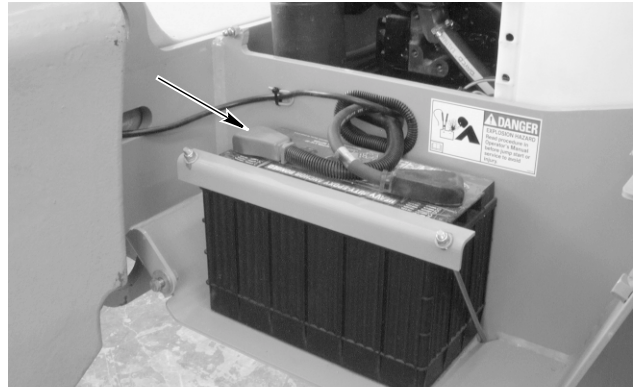

BD01D161

Disconnect battery cable from RH battery positive post. Put a plastic cap over the positive post.

STEP 25

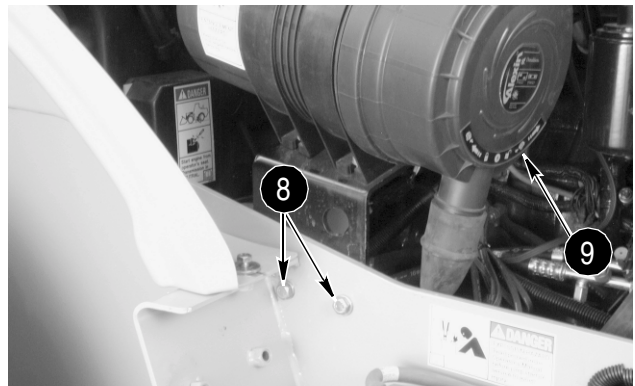

BD01D162

Support air cleaner assembly (9) and remove two lock nuts, washers, bolts (8), and washers. Remove air cleaner and support as an assembly.

STEP 26

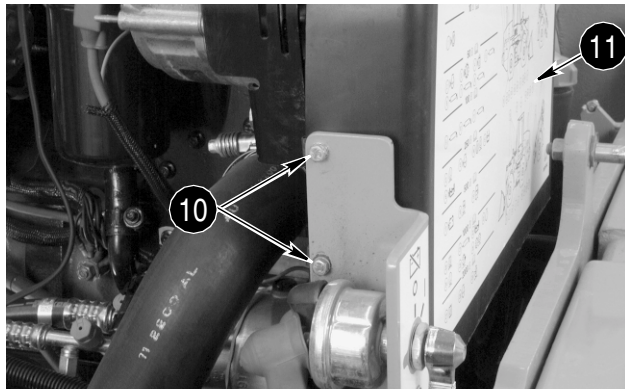

BD01D165

Remove four bolts (10) and washers securing drive belt guard (11) to master disconnect switch mounting bracket and belt guard bracket.

STEP 27

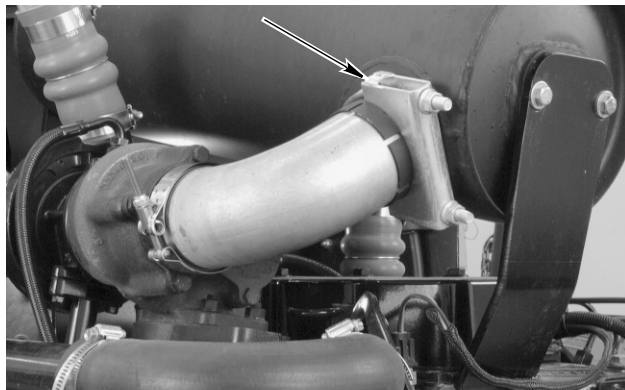

BD01D168

Remove clamp securing elbow to muffler.

STEP 28

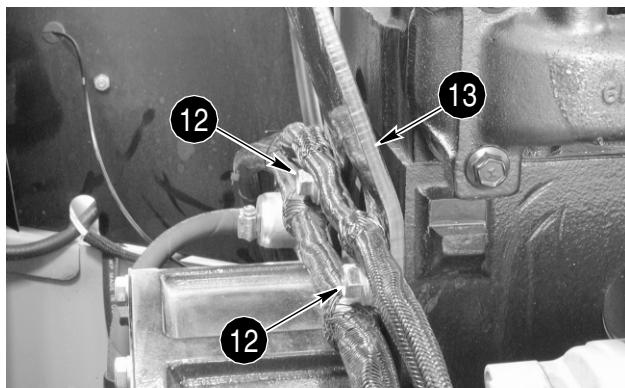

BD01D166

At front of engine, remove two bolts (12) and washers securing wiring harness clamps and muffer mounting bracket (13).

STEP 29

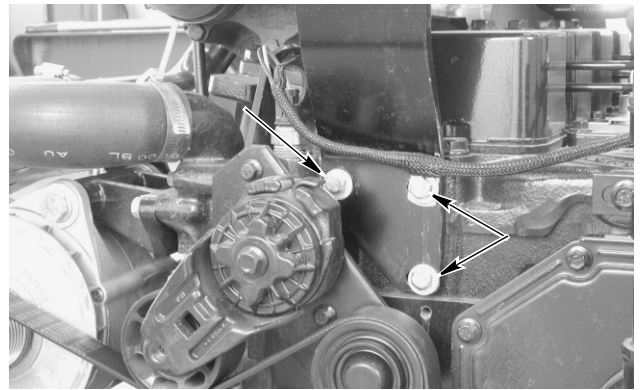

BD01D167

Support muffer and brackets and remove three bolts and washers at rear of engine. Remove muffer and brackets as an assembly from engine.

STEP 30

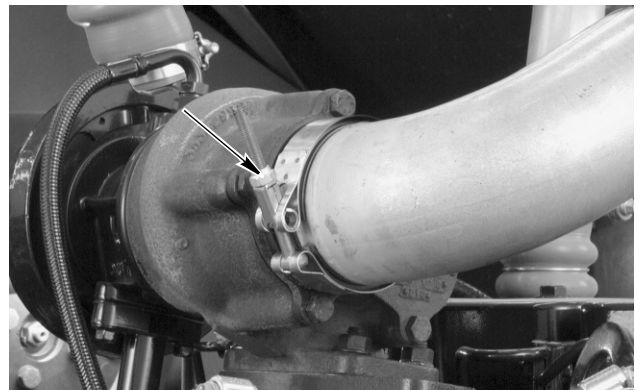

BD01D169

Loosen clamp and remove tube from turbocharger.

STEP 31



BD01D170

Loosen two clamps. Remove tube and hose as an assembly.

STEP 32



BD01D172

Loosen two clamps. Remove tube and hose as an assembly.

STEP 33

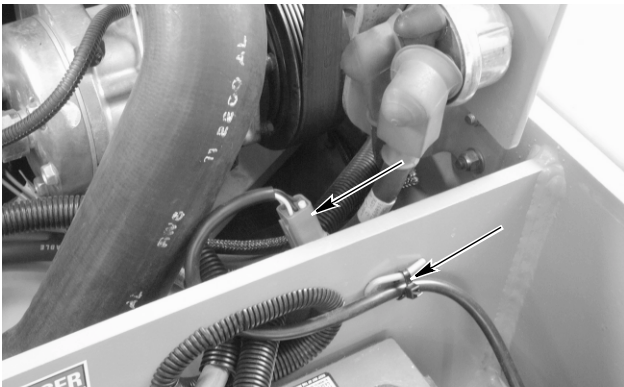

BD01D177

Cut, remove, and discard tie strap securing LH rear combination lamp wire. Identify, tag, and disconnect rear chassis wiring harness connector from combination lamp connector. Repeat this step for RH rear combination lamp.

STEP 34

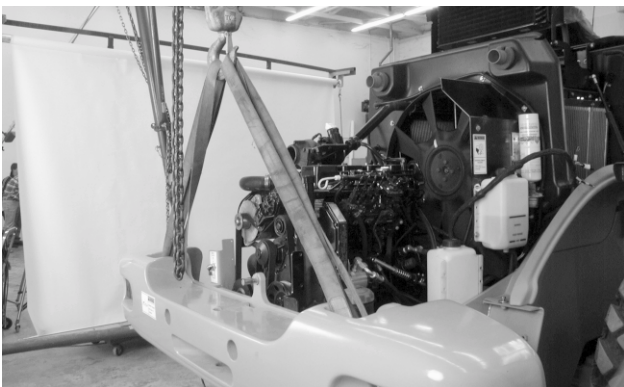

BD01D179

Connect lifting equipment to rear counterweight. Take up all slack in lifting equipment.

STEP 35

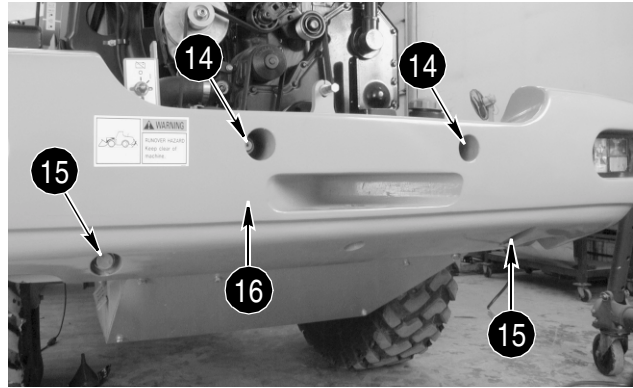

BD01D178

Remove two nuts (14) and washers and two bolts (15), washers, and nuts. Remove counterweight (16) from loader and place on pallet.

STEP 36

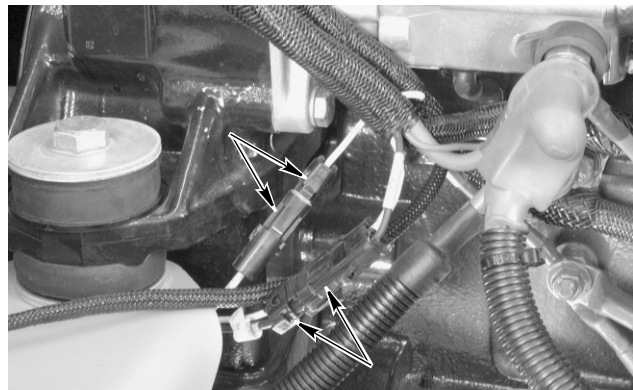

BD01D164

Identify, tag, and disconnect the four connectors.

STEP 37

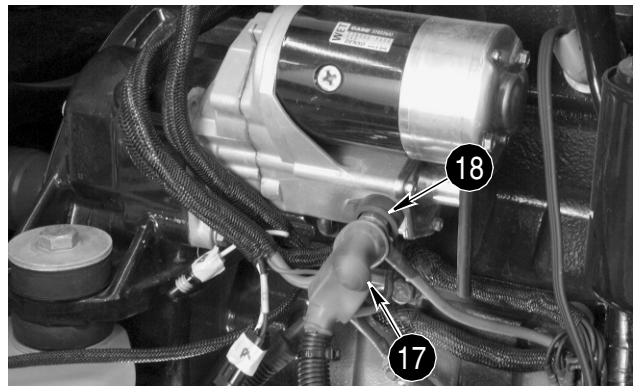

BD01D173

Pull rubber boot (17) back from starter B+ terminal (18). Remove the nut, lock washer, and flat washer from B+ terminal. Identify, tag, and disconnect the wires from terminal.

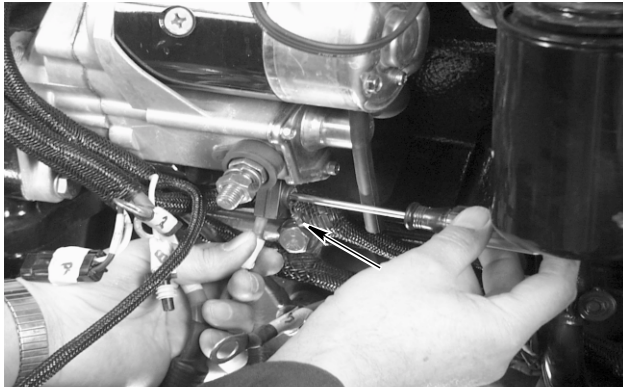
STEP 38

BD01D250

Identify and tag wire connected to starter solenoid terminal. Pull the plastic cap from starter solenoid terminal. Using a Phillips screwdriver, loosen terminal screw and disconnect wire from terminal.

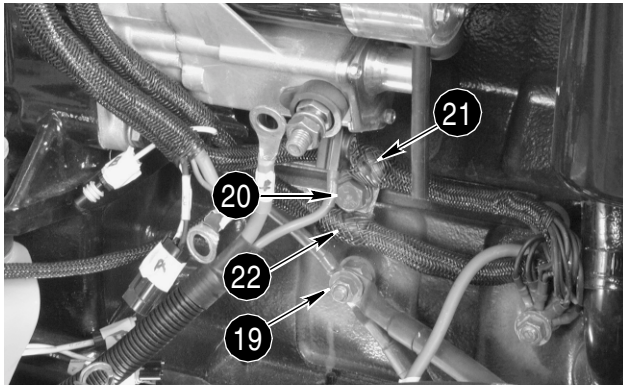
STEP 39

BD01D174

Remove nut (19) and washer. Disconnect ground cables from engine ground stud. Move ground cables away from engine. Remove bolt (20), lock washer, and washer securing harness clamps to engine. Top harness (21) is rear chassis wiring harness; bottom harness (22) is engine wiring harness.

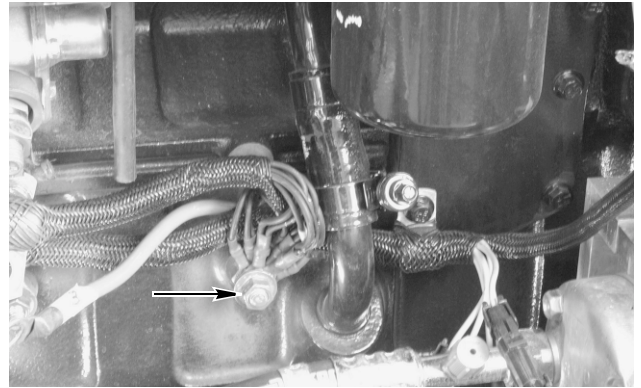
STEP 40

BD01D175

Remove nut and washer from engine ground stud. Disconnect the five ground wires of the rear chassis wiring harness from the stud.

STEP 41

BD01D176

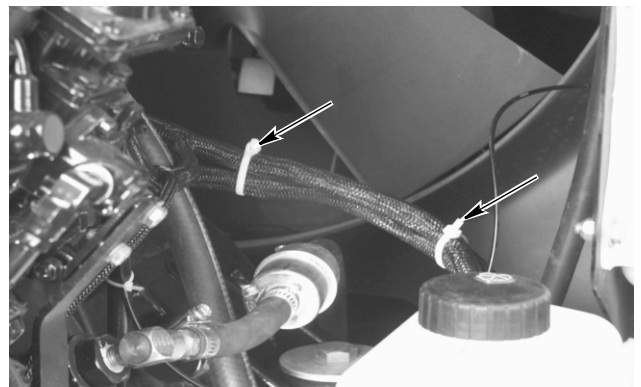

BD01D257

Route rear chassis wiring harness to front of engine. Cut, remove, and discard two tie straps then route harness to RH side of engine compartment and away from engine.

STEP 42

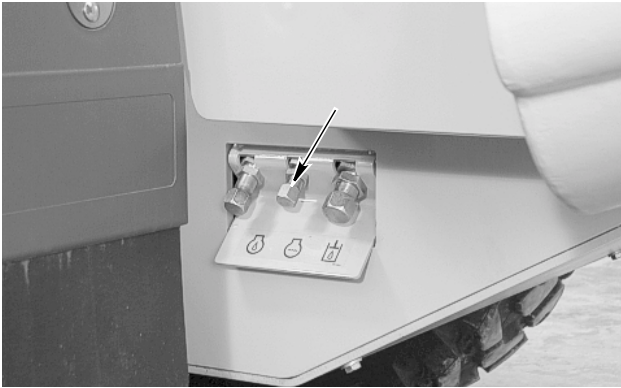

BD00M031

Put a 37.8 liter (10 gallon) container below radiator drain. Remove cap and drain coolant into container. Install cap after coolant has drained.

STEP 43

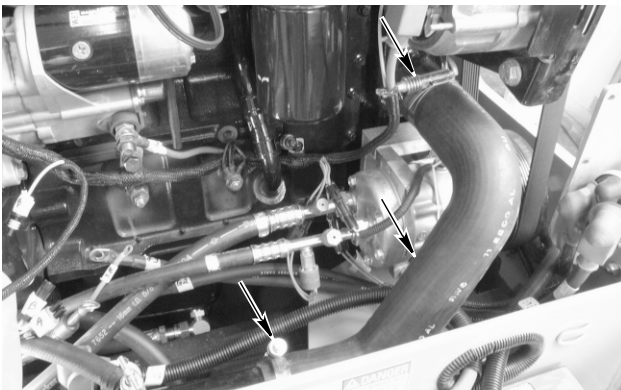

BD01D184

Loosen two hose clamps. Remove bottom hose.

STEP 44

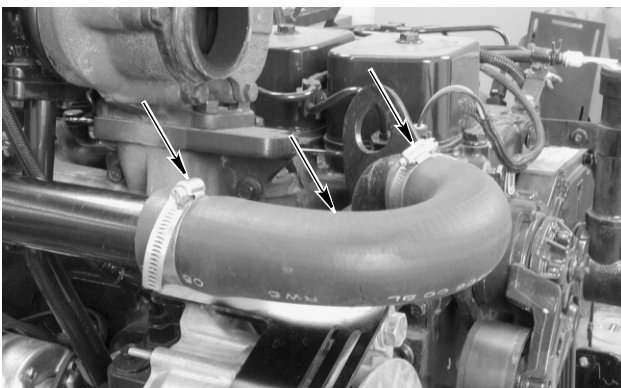

BD01D185

Loosen two hose clamps. Remove upper hose.

STEP 45

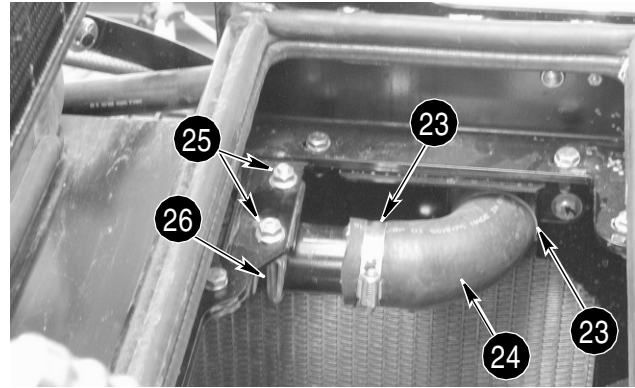

BD01D188

At top of cooling system frame, loosen two hose clamps (23). Remove hose (24). Remove two nuts (25) securing U-bolt (26). Remove U-bolt, clamp, and spacer.

STEP 46

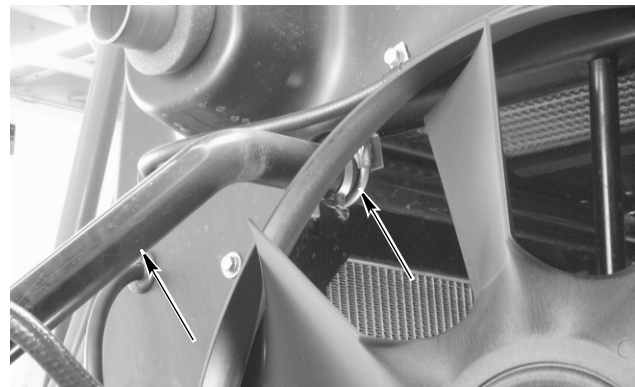

BD01D192

Remove two nuts securing U-bolt holding top coolant pipe. Remove U-bolt, clamp, and spacer. Remove top coolant pipe from cooling system frame.

STEP 47



BD01D189

Put a 12.7 mm (1/2 inch) drive breaker bar or ratchet in bracket for automatic belt tensioner. Lift up on breaker bar or ratchet to release drive belt tension and remove belt.

STEP 48

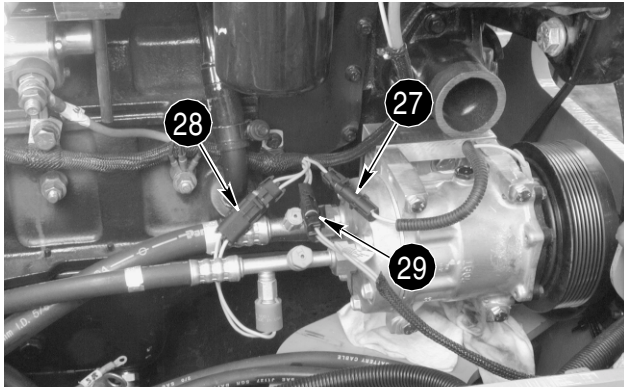

BD01D180

If loader is equipped with air conditioning, identify, tag, and disconnect the engine wiring harness connectors from air compressor clutch connector (27) and high pressure switch connector (28). Disconnect engine wiring harness connector from disconnect switch wiring harness connector (29).

STEP 49

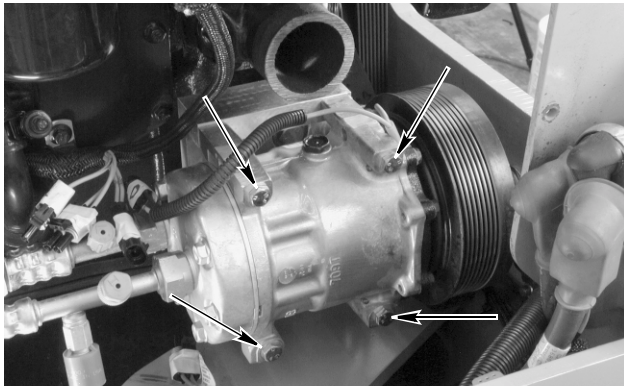

BD01D193

Support air conditioning compressor and remove four bolts.

STEP 50

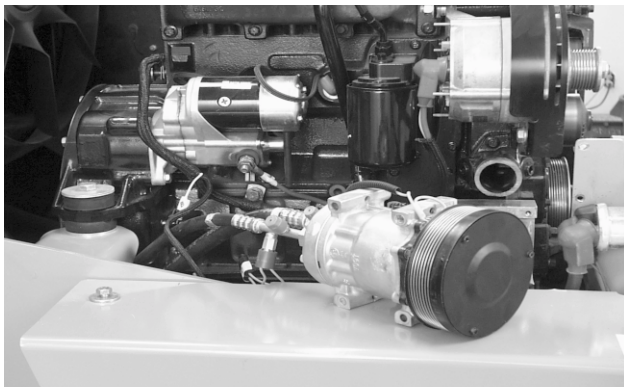

BD01D218

Install battery cover. Put air conditioning compressor on battery cover.

STEP 51



BD00M031

Put a 18.9 liter (5 gallon) container below engine oil drain. Remove cap and drain engine oil into container. Install cap after oil has drained.

STEP 52

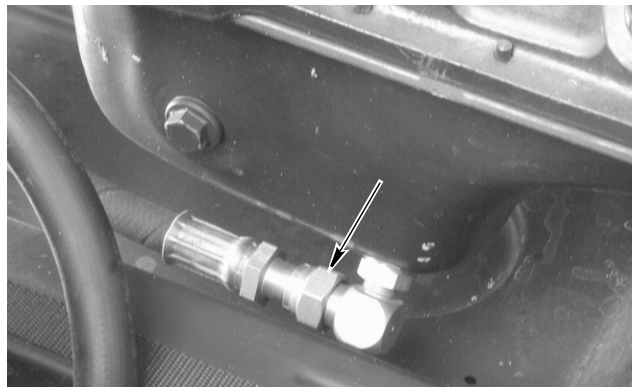

BD01D194

Disconnect hose from fitting installed in engine oil pan. Install a plug in hose and a cap on fitting.

STEP 53

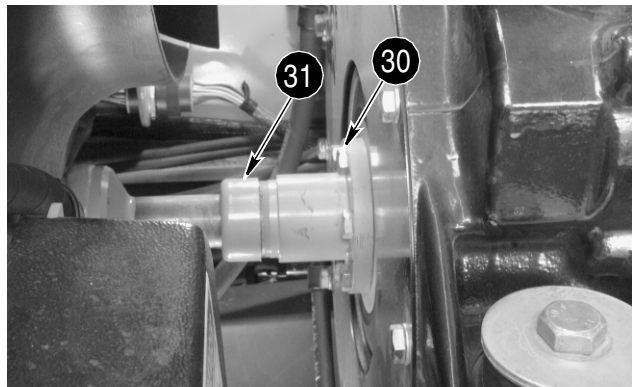

BD01D200

At front of engine, remove six bolts (30) securing drive shaft (31) to engine coupling. Use a pry bar to move drive shaft away from engine coupling.

STEP 54

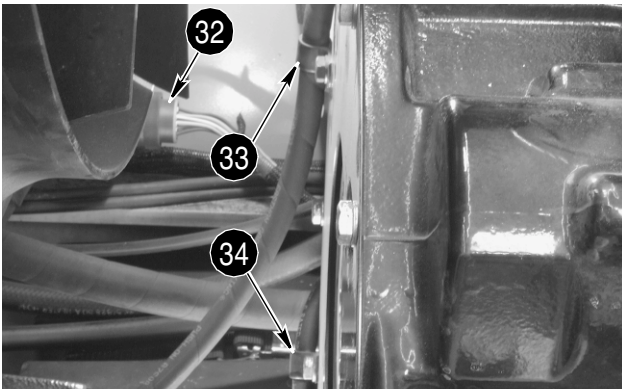

BD01D208

Disconnect engine wiring harness connector (32) from transmission wiring harness bulkhead connector. Remove clamp (33) securing fuel supply hose to engine flywheel housing. Remove two clamps (34) securing fuel return hose to engine.

STEP 55

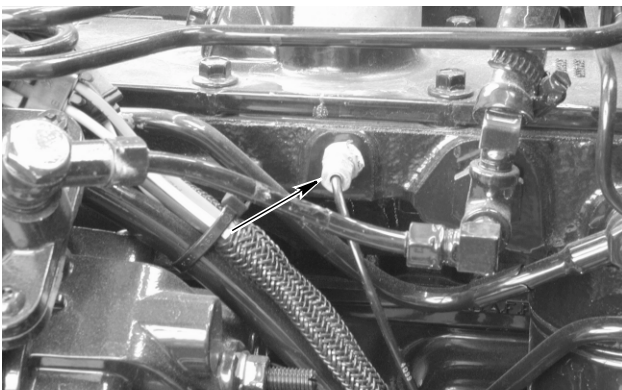

BD01D209

If equipped, disconnect ether start nozzle from intake manifold.

STEP 56

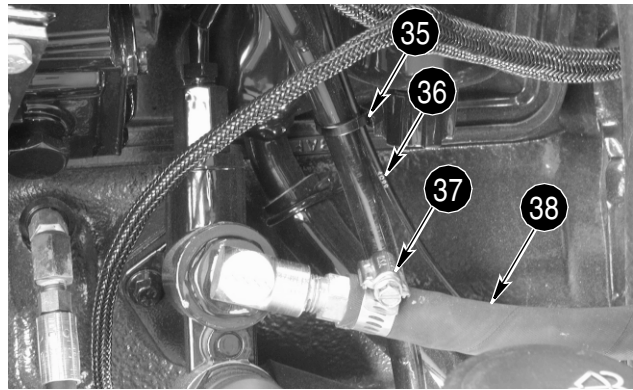

BD01D210

Cut, remove, and discard tie strap (35) securing ether start tube (36). Move ether start tube away from engine. Loosen clamp (37). Tag and disconnect fuel supply hose (38) from primer pump. Plug hose and cap fitting to prevent intrusion of foreign matter into fuel system.

STEP 57

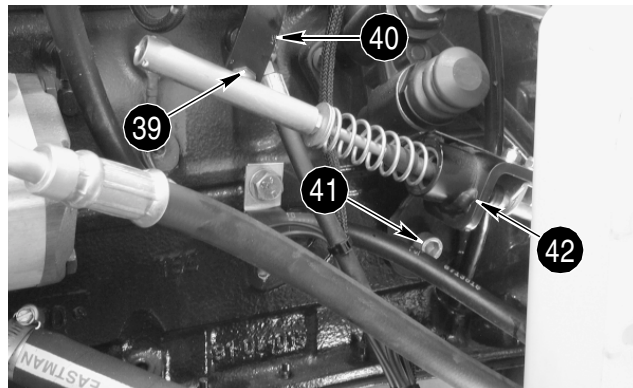

BD01D212

Remove nut and washer securing ball joint (39) to throttle lever (40). Remove two socket head bolts (41) and washers securing throttle bracket (42) to engine. Move throttle bracket with throttle cable and ball joint attached away from engine.

STEP 58

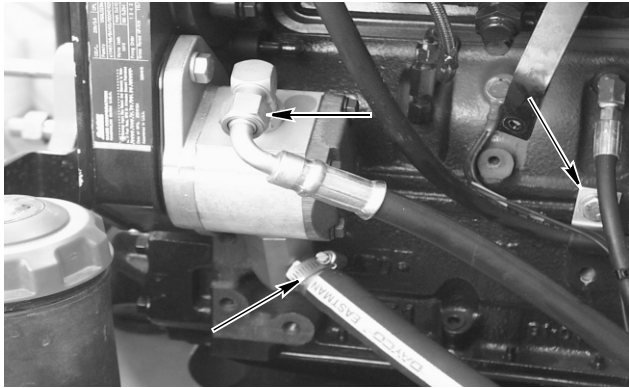

BD01D215

Connect a vacuum pump to hydraulic reservoir. If a vacuum pump is not available, drain the hydraulic oil (hydraulic reservoir holds 68.5 liters (18 gallons) of oil). Turn on vacuum pump (if available). Tag, disconnect, and plug hoses connected to brake pump. Plug hoses securely and cap fittings. Turn off vacuum pump. Remove clamp securing fuel return hose to engine.

STEP 59

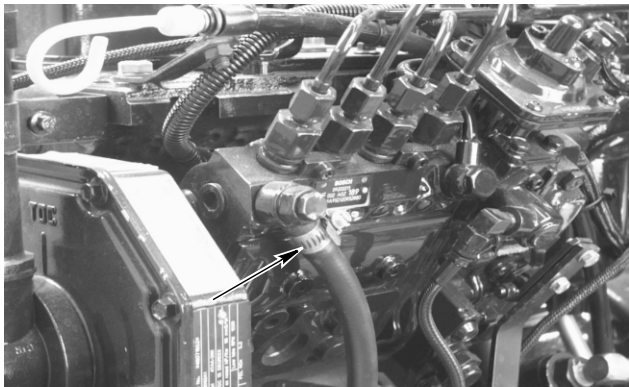

BD01D216

Tag and disconnect fuel return hose. Plug hose and cap fitting.

STEP 60

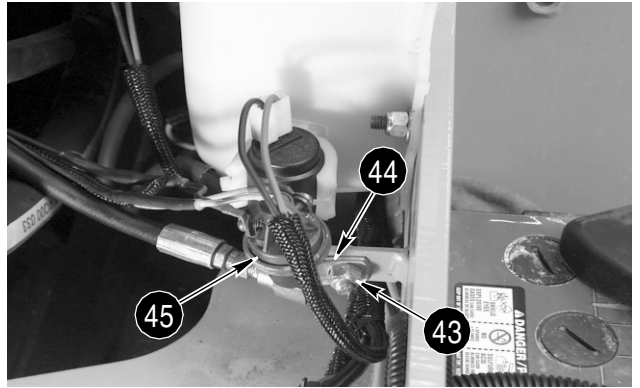

BD01D217

Remove nut (43), washer, and bolt securing clamp (44) and engine oil pressure sender (45) to rear chassis. Remove these parts as an assembly and secure to engine using suitable means.

STEP 61

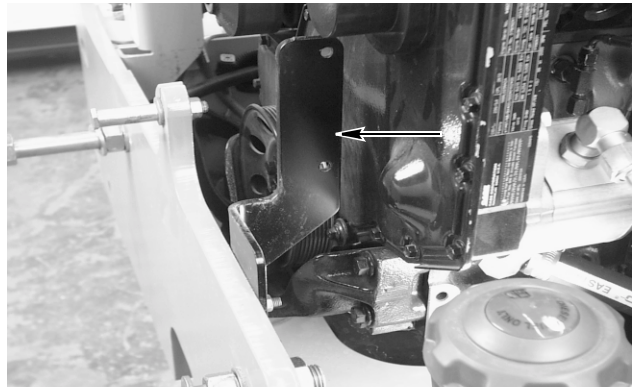

BD01D219

Remove two nuts and remove belt guard bracket.

STEP 62



BD01D203

If equipped, disconnect ether start solenoid connector from engine wiring harness connector.

STEP 63

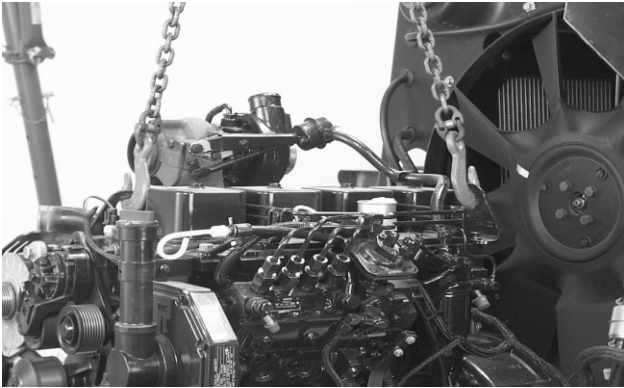

BD01D220

Connect lifting equipment to engine lifting brackets. Take up all slack in lifting equipment.

STEP 64



BD01D206

At front of engine, remove nut, bolt, and two washers securing both sides of engine to rear chassis.

STEP 65

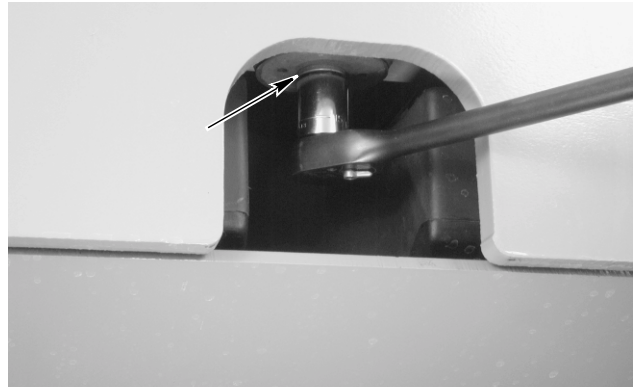

BD01D181

At rear of rear chassis, between fuel tank mounting plate and rear chassis, remove bolt and washer securing rear of engine to rear chassis.

STEP 66

Slowly raise engine from rear chassis. Be sure all harness connections and hoses have been disconnected and out of the way. Remove engine from machine.

Installation

STEP 67

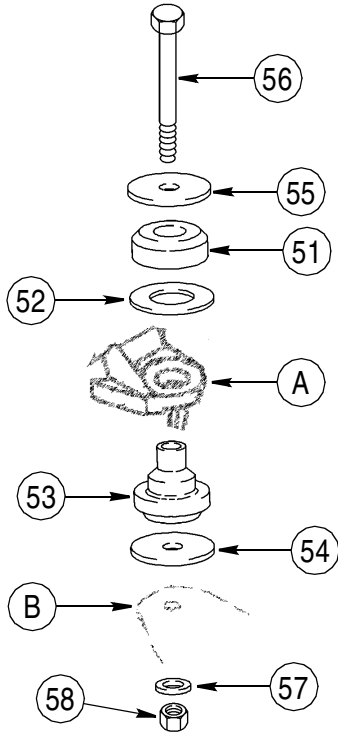

- | | |
|---------------------|-----------------|
| 51. RUBBER ISOLATOR | 56. BOLT |
| 52. WASHER | 57. WASHER |
| 53. RUBBER ISOLATOR | 58. NUT |
| 54. WASHER | A. ENGINE |
| 55. WASHER | B. REAR CHASSIS |

If engine front rubber isolators require replacement, remove and discard isolators (51 and 53). Install new rubber isolator (53), washer (52), then rubber isolator (51).

BC01D128

STEP 68

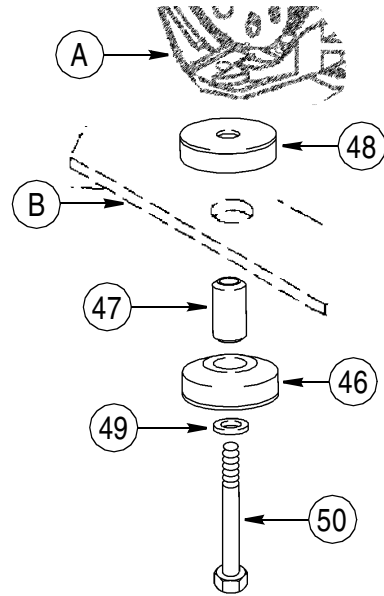

- | | |
|---------------------|-----------------|
| 46. RUBBER ISOLATOR | 50. BOLT |
| 47. SPACER | A. ENGINE |
| 48. RUBBER ISOLATOR | B. REAR CHASSIS |
| 49. WASHER | |

BC01D129

If engine rear rubber isolators require replacement, remove and discard isolators (46 and 48) and spacer (47). Install new rubber isolators (46 and 48) and spacer (47) in rear chassis.

STEP 69

Slowly raise engine and move into position over rear chassis. Be sure all harness connections and hoses are out of the way then lower engine. Put washer (54) between front rubber isolator (53) and rear chassis. Install washer (55), bolt (56), washer (57), and nut (58) in engine front isolators. Lower engine into position. Install washer (49) and bolt (50) in rear isolator.

STEP 70

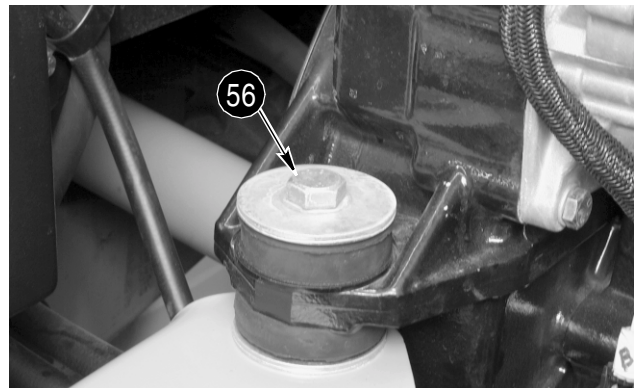

BD01D206

At front of engine, tighten two bolts (56) to a torque of 244 to 298 Nm (180 to 220 lb-ft).

STEP 71

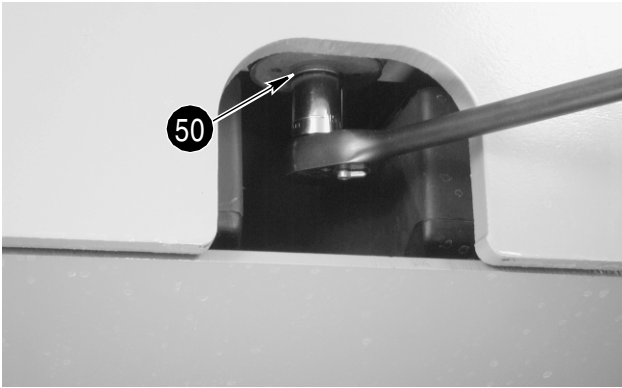

BD01D181

At rear of rear chassis, between fuel tank mounting plate and rear chassis, tighten bolt (50) to a torque of 244 to 298 Nm (180 to 220 lb-ft).

STEP 72



BD01D220

Disconnect lifting equipment from engine lifting brackets.

STEP 73



BD01D203

At right side of engine compartment, connect ether start solenoid connector to engine wiring harness connector if equipped.

STEP 74

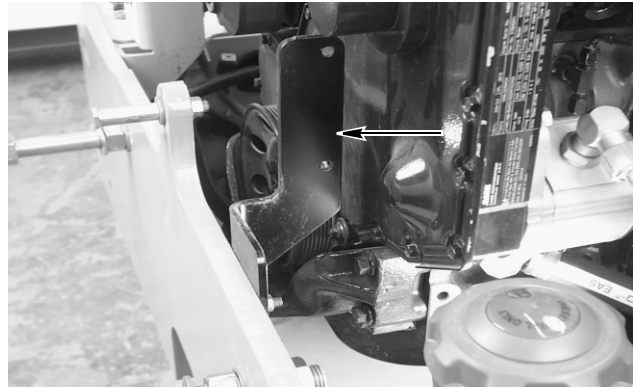

BD01D219

Position belt guard bracket on rear chassis and secure using two nuts.

STEP 75

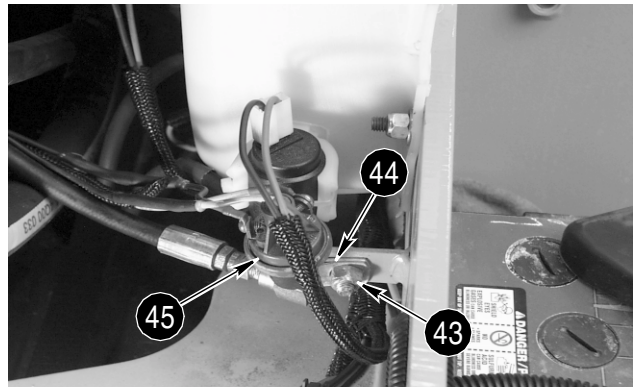

BD01D217

Position engine oil pressure sender (45) and clamp (44) on tab of rear chassis. Install nut (43), washer, and bolt to secure clamp and engine oil pressure sender to rear chassis.

STEP 76

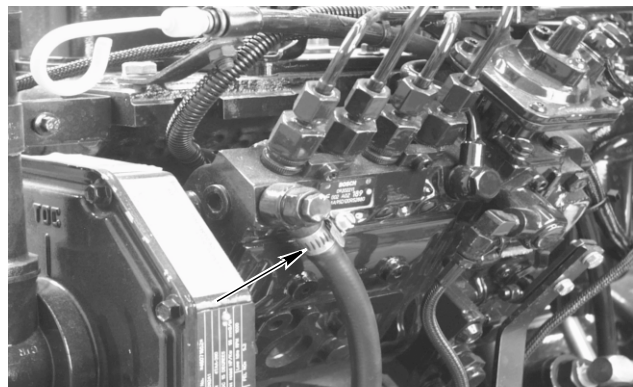

BD01D216

Remove plug from hose and cap from fuel injection pump fitting. Connect fuel return hose to fuel injection pump following tag installed during removal. Position and tighten clamp. Remove and discard tag.

STEP 77

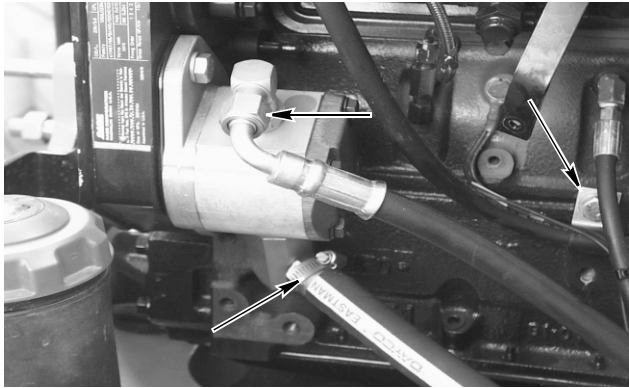

BD01D215

Install clamp to secure fuel return hose to engine. Turn on vacuum pump connected to hydraulic reservoir. Remove caps from fittings and plugs from hoses. Connect hoses to brake pump following tags installed during removal. Remove and discard tags. Turn off and disconnect vacuum pump from hydraulic reservoir.

STEP 78

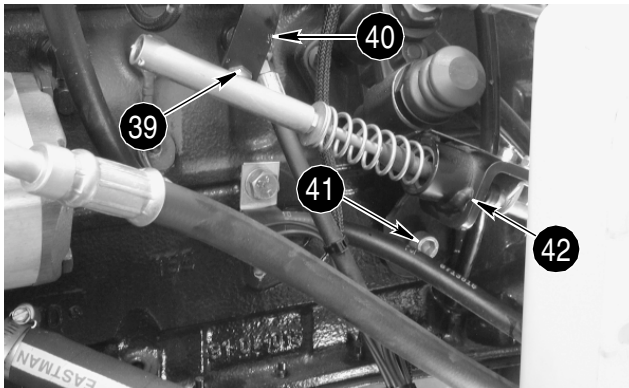

BD01D212

Position throttle bracket with throttle cable and ball joint attached on engine. Install two washers and socket head bolts (41) to secure throttle bracket (42) to engine. Connect ball joint (39) to throttle lever (40) and secure with nut and washer.

STEP 79

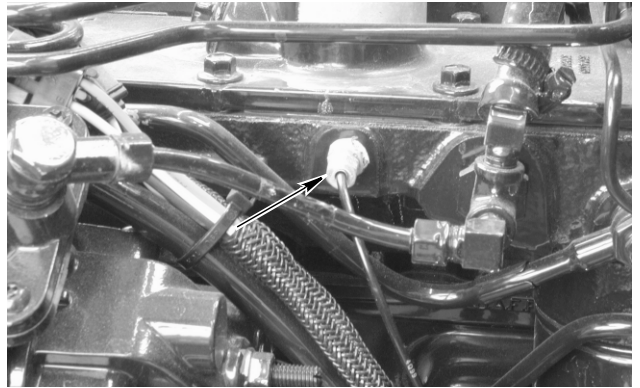

BD01D209

If equipped, connect ether start nozzle to intake manifold.

STEP 80

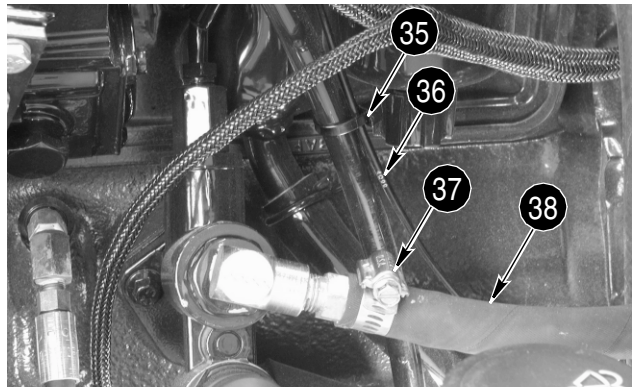

BD01D210

Remove cap from fitting and plug from hose. Connect fuel supply hose (38) to primer pump following tag installed during removal. Position and tighten clamp (37). Remove and discard tag. Install a new tie strap (35) to secure ether start tube (36).

STEP 81

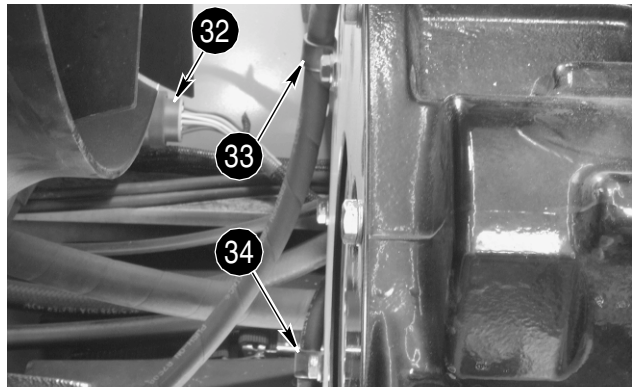

BD01D208

Position fuel return hose and secure using two clamps (34). Position fuel supply hose and secure using clamp (33). Connect engine wiring harness connector (32) to transmission wiring harness bulkhead connector.

STEP 82

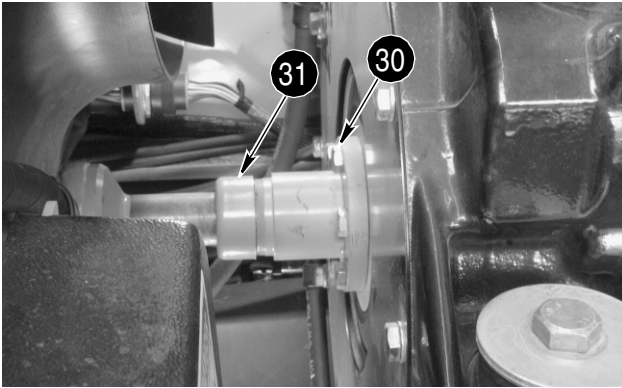

BD01D200

At front of engine, position drive shaft (31) on engine coupling. Install six bolts (30) to secure drive shaft (31) to engine coupling. Tighten the six bolts to a torque of 53 to 62 Nm (39 to 46 lb-ft).

STEP 83

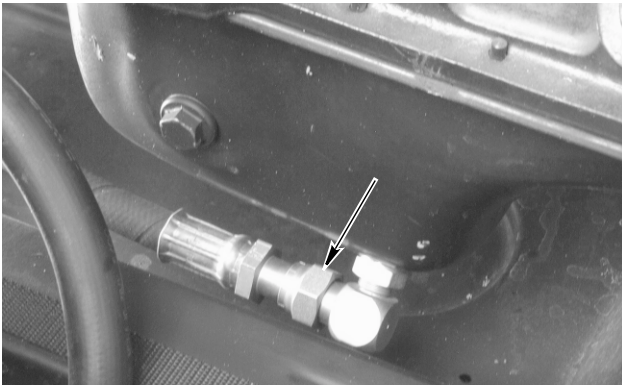

BD01D194

Remove plug from oil drain hose and cap from fitting installed in engine oil pan. Connect and tighten hose to fitting.

STEP 84

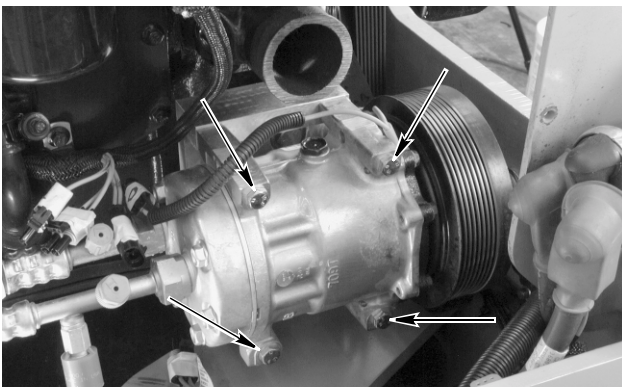

BD01D193

If loader is equipped with air conditioning, position and support air conditioning compressor and install four bolts.

STEP 85

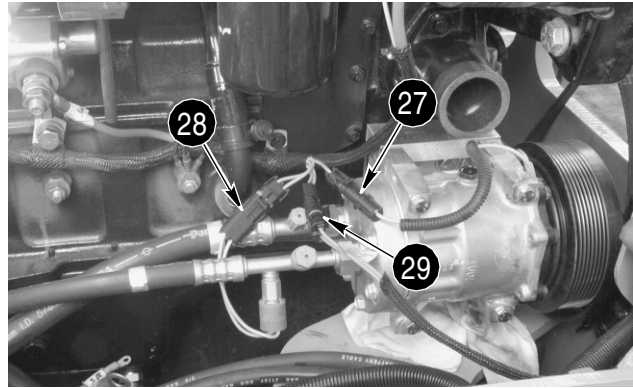

BD01D180

Connect engine wiring harness connector to disconnect switch wiring harness connector (29). If loader is equipped with air conditioning, connect the engine wiring harness connectors to air compressor clutch connector (27) and high pressure switch connector (28) following tags installed during removal. Remove and discard tags.

STEP 86

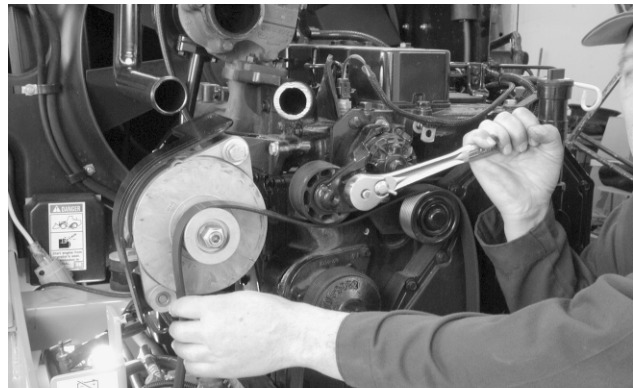

BD01D189

Route drive belt on pulleys then put a 12.7 mm (1/2 inch) drive breaker bar or ratchet in bracket for automatic belt tensioner. Lift up on breaker bar or ratchet and position drive belt then release belt tensioner to put tension on drive belt.

STEP 87

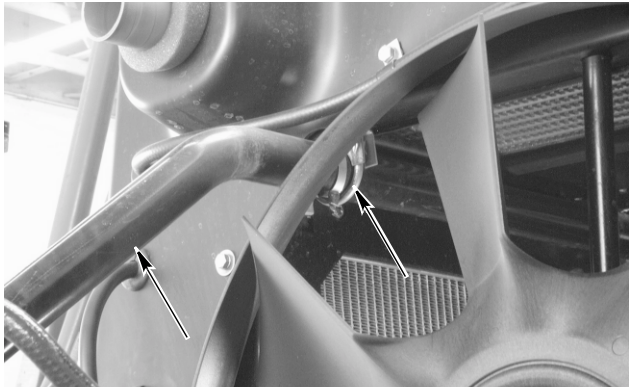

BD01D192

Insert top coolant pipe in cooling system frame. Install spacer, clamp, and U-bolt then install two nuts. Do not tighten nuts at this time.

STEP 88

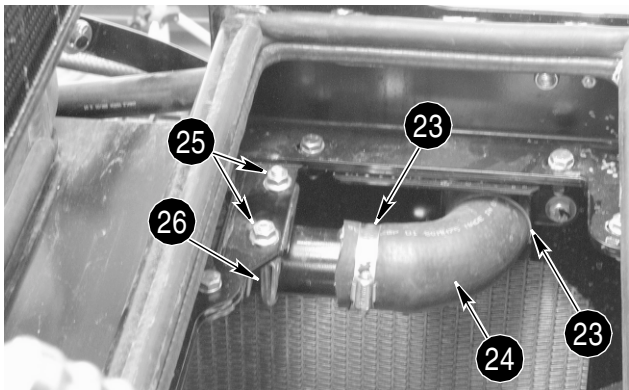

BD01D188

At top of cooling system frame, install spacer, clamp, and U-bolt (26) and secure using two nuts (25). Do not tighten nuts at this time. Install hose (24). Position clamps (23) and tighten clamps to a torque of 10.1 to 11.3 Nm (90 to 100 lb-inch). Tighten four nuts securing two U-bolts.

STEP 89

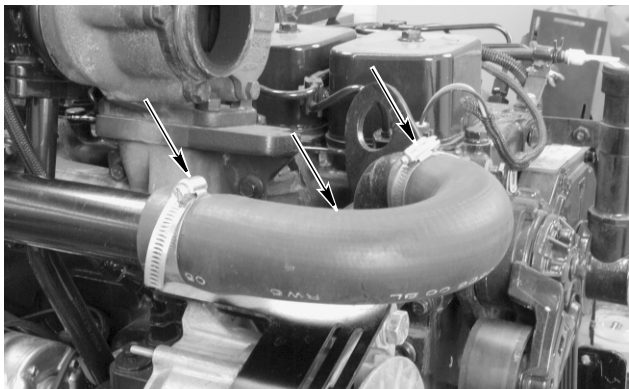

BD01D185

Install upper hose. Position and tighten hose clamps.

STEP 90

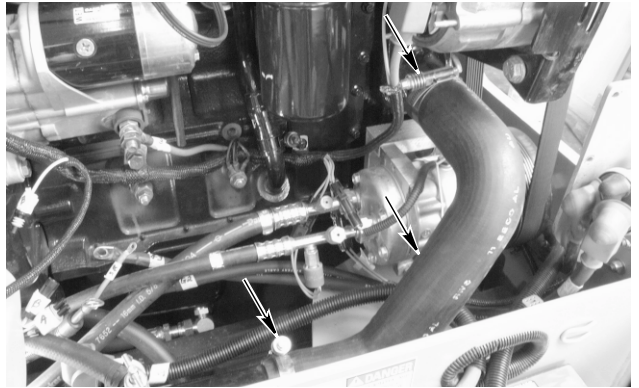

BD01D184

Install bottom hose. Position and tighten hose clamps.

STEP 91

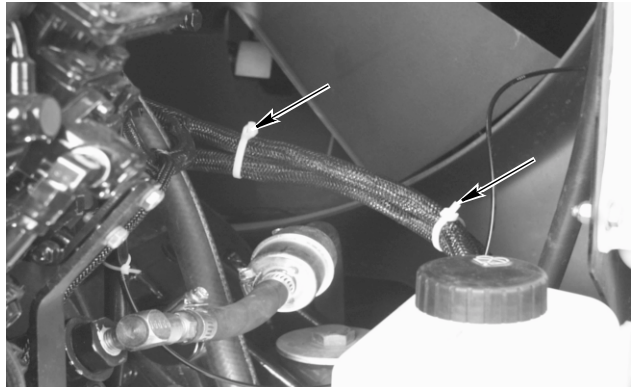

BD01D257



BD01D176

Route rear chassis wiring harness around front of engine to LH side of engine compartment. Install two new tie straps.

STEP 92

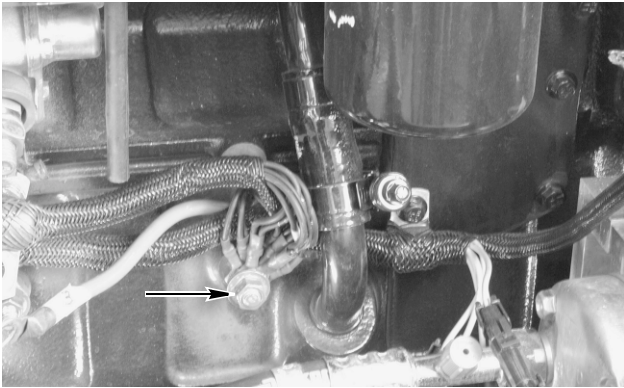

BD01D175

Connect the five ground wires of the rear chassis wiring harness to the stud. Install washer and nut to secure ground wires to engine ground stud.

STEP 93

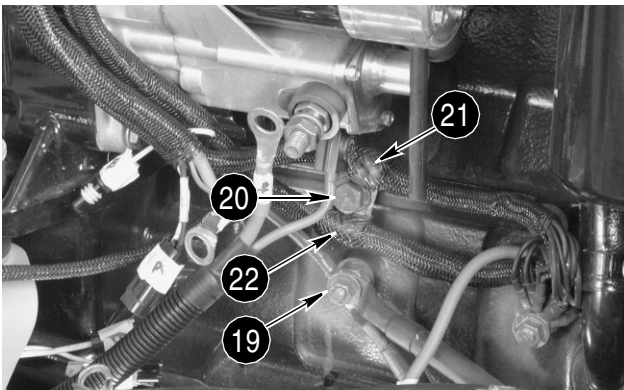

BD01D174

Install bolt (20), lock washer, and washer to secure harness clamps to engine. Top harness (21) is rear chassis wiring harness; bottom harness (22) is engine wiring harness. Connect ground cables to engine ground stud. Install washer and nut (19) to secure ground cables.

STEP 94

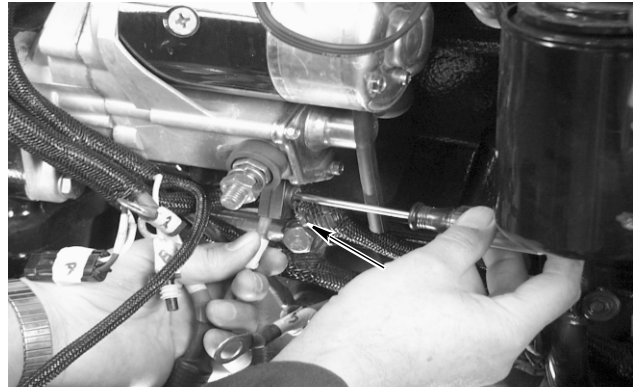

BD01D250

Connect wire to starter solenoid terminal following tag installed during removal. Using a Phillips screwdriver, tighten terminal screw. Install plastic cap in terminal screw recess. Remove and discard tag.

STEP 95

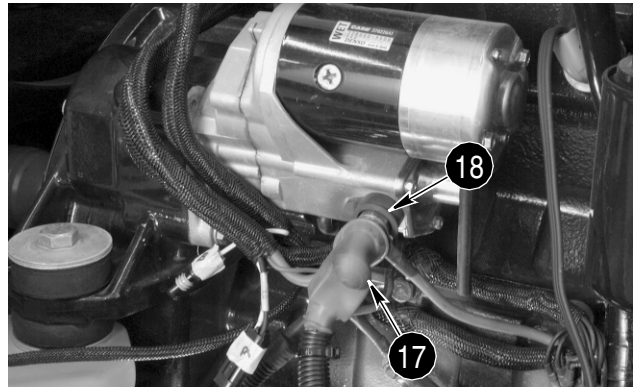

BD01D173

Connect wires to starter B+ terminal (18) following tags installed during removal. Install flat washer, lock washer, and nut to secure wires. Position rubber boot (17) over starter B+ terminal. Remove and discard tags from wires.

STEP 96



BD01D164

Connect connectors following tags installed during removal. Remove and discard tags.

STEP 97

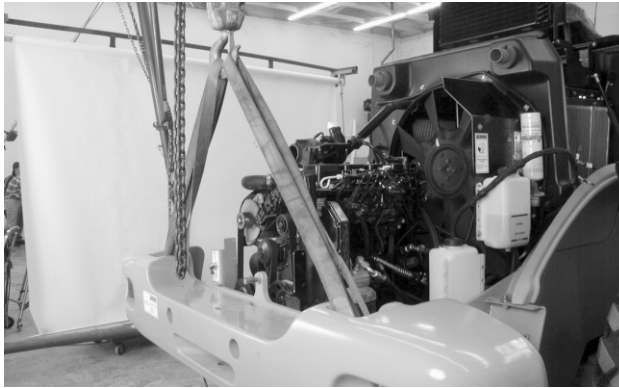

BD01D179

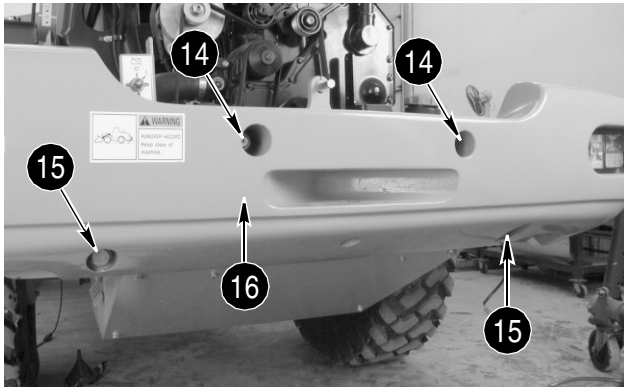

BD01D178

Move counterweight into position at rear of loader. Install two nuts (14) and washers and two bolts (15), washers, and nuts. Tighten nuts to a torque of 693 to 780 Nm (510 to 575 lb-ft). Tighten bolts to a torque of 955 to 1075 Nm (704 to 793 lb-ft).

STEP 98

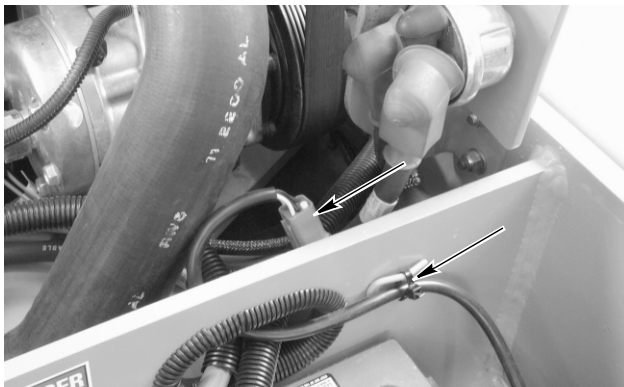

BD01D177

Connect rear chassis wiring harness connector to combination lamp connector following tag installed during removal. Install new tie strap to secure LH rear combination lamp wire. Remove and discard tags. Repeat this step for RH rear combination lamp.

STEP 99



BD01D172

Install tube and hose as shown. Position clamps and tighten to a torque of 10.1 to 11.3 Nm (90 to 100 lb-inch).

STEP 100



BD01D170

Install tube and hose as shown. Position clamps and tighten to a torque of 10.1 to 11.3 Nm (90 to 100 lb-inch).

STEP 101

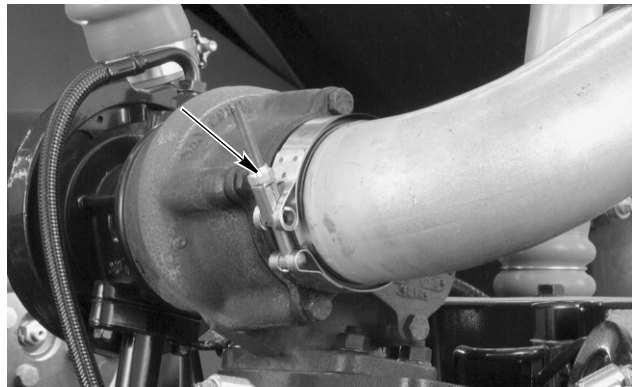

BD01D169

Position tube on turbocharger. Do not tighten clamp at this time.



Suggest:

If the above button click is invalid.

Please download this document

first, and then click the above link

to download the complete manual.

Thank you so much for reading

STEP 102

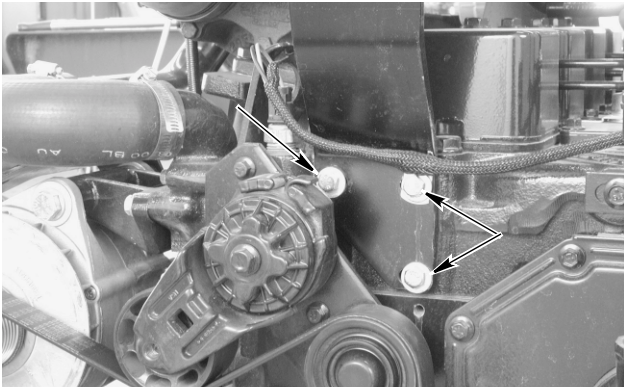

BD01D167

Install and support muffler and brackets on engine while connecting muffler to tube installed in Step 101. Install three washers and bolts at rear of engine finger tight.

STEP 103

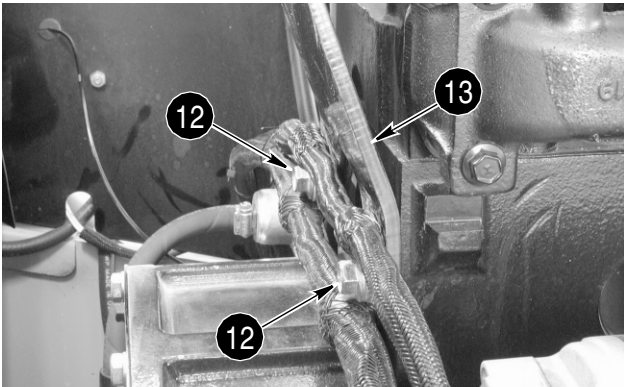

BD01D166

At front of engine, position wiring harness clamps on muffler mounting bracket (13). Secure clamps and muffler mounting bracket using two washers and bolts (12). Tighten bolts to a torque of 118 to 133 Nm (87 to 98 lb-ft). Tighten the three rear bolts installed in Step 102 to a torque of 34 to 39 Nm (25 to 28 lb-ft).

STEP 104

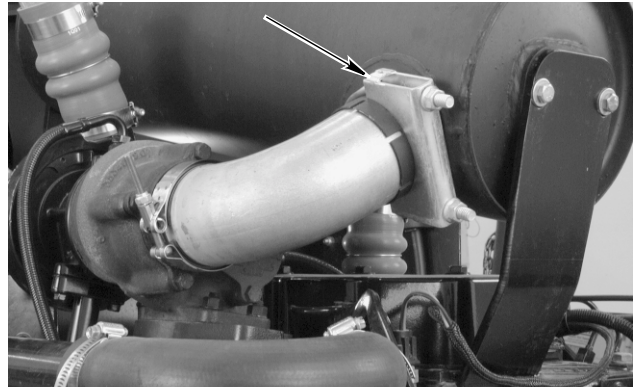

BD01D168

Position clamp securing elbow to muffler. Tighten clamp to a torque of 20 to 25 Nm (15 to 18 lb-ft). Tighten clamp securing opposite end of elbow to turbocharger to a torque of 4.8 to 5.2 Nm (42.5 to 46 lb-inch).

STEP 105

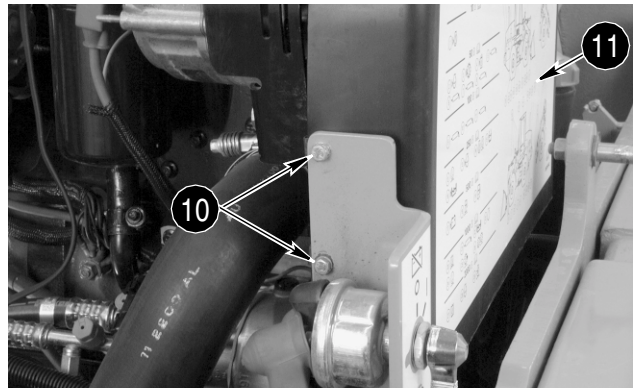

BD01D165

Position drive belt guard (11) and secure using four washers and bolts (10) to master disconnect switch mounting bracket and belt guard bracket.

STEP 106

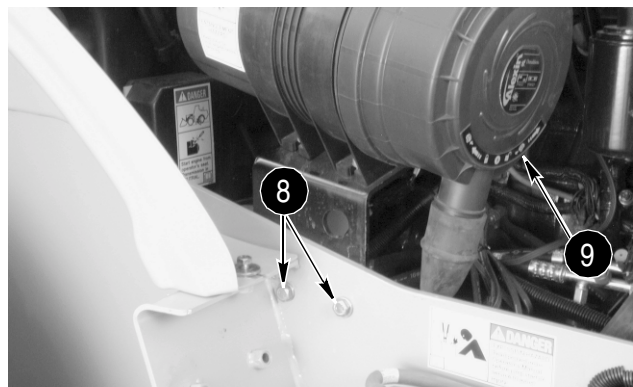

BD01D162

Position air cleaner assembly (9) and support as an assembly. Secure using two bolts (8), four washers, and two lock nuts.

<https://www.ebooklibonline.com>

Hello dear friend!

Thank you very much for reading.

Enter the link into your browser.

The full manual is available for immediate download.

<https://www.ebooklibonline.com>