

21F
121F
221F
321F
Tier 4A (interim)
Compact Wheel Loader

SERVICE MANUAL

Part number 47829079C

1st edition English

April 2017





SERVICE MANUAL

121F XT, 121F ZB, 21F XT, 21F ZB, 221F HS, 221F STD, 321F HS, 321F STD

Link Product / Engine

Product	Market Product	Engine
121F XT CWL TIER4 TOOL CARRIER	North America	F5HFL463C*F001
121F ZB CWL TIER4 Z-BAR	North America	F5HFL463C*F001
21F XT CWL TIER4 TOOL CARRIER	North America	F5HFL463B*F001
21F ZB CWL TIER4 Z-BAR	North America	F5HFL463B*F001
221F HS CWL TIER4 TOOL CARRIER	North America	F5HFL463A*F001
221F STD CWL TIER4 Z-BAR	North America	F5HFL463A*F001
321F HS CWL TIER4 TOOL CARRIER	North America	F5HFL463A*F001
321F STD CWL TIER4 Z-BAR	North America	F5HFL463A*F001

<https://www.ebooklibonline.com>

Hello dear friend!

Thank you very much for reading.

Enter the link into your browser.

The full manual is available for immediate download.

<https://www.ebooklibonline.com>

Contents

INTRODUCTION

Engine.....	10
[10.001] Engine and crankcase	10.1
[10.216] Fuel tanks	10.2
Four-Wheel Drive (4WD) system	23
[23.314] Drive shaft.....	23.1
Front axle system	25
[25.100] Powered front axle	25.1
[25.102] Front bevel gear set and differential	25.2
[25.108] Final drive hub, steering knuckles, and shafts	25.3
Rear axle system.....	27
[27.100] Powered rear axle.....	27.1
[27.106] Rear bevel gear set and differential	27.2
[27.120] Planetary and final drives	27.3
[27.124] Final drive hub, steering knuckles, and shafts	27.4
Hydrostatic drive.....	29
[29.100] Transmission and steering hydrostatic control	29.1
Brakes and controls	33
[33.202] Hydraulic service brakes	33.1
[33.110] Parking brake or parking lock	33.2
[33.204] Front axle brake	33.3
Hydraulic systems.....	35
[35.000] Hydraulic systems.....	35.1
[35.300] Reservoir, cooler, and filters.....	35.2
[35.104] Fixed displacement pump.....	35.3
[35.106] Variable displacement pump	35.4

[35.359] Main control valve	35.5
[35.357] Pilot system	35.6
[35.525] Auxiliary hydraulic valves and lines	35.7
[35.600] High flow hydraulics	35.8
[35.355] Hydraulic hand control	35.9
[35.353] Hydraulic travel system	35.10
[35.701] Front loader arm hydraulic system	35.11
[35.723] Front loader bucket hydraulic system	35.12
[35.734] Tool quick coupler hydraulic system	35.13
Frames and ballasting	39
[39.100] Frame	39.1
[39.140] Ballasts and supports	39.2
Steering.....	41
[41.101] Steering control	41.1
[41.200] Hydraulic control components.....	41.2
[41.216] Cylinders	41.3
Cab climate control	50
[50.100] Heating.....	50.1
[50.200] Air conditioning.....	50.2
Electrical systems	55
[55.000] Electrical system	55.1
[55.100] Harnesses and connectors.....	55.2
[55.045] Front axle control system	55.3
[55.050] Heating, Ventilation, and Air-Conditioning (HVAC) control system.....	55.4
[55.408] Warning indicators, alarms, and instruments	55.5
[55.DTC] FAULT CODES.....	55.6
Front loader and bucket.....	82
[82.100] Arm.....	82.1

[82.300] Bucket	82.2
Platform, cab, bodywork, and decals	90
[90.150] Cab	90.1



INTRODUCTION

Basic instructions - Important notice regarding equipment servicing

All repair and maintenance work listed in this manual must be carried out only by qualified dealership personnel, strictly complying with the instructions given, and using, whenever possible, the special tools.

Anyone who performs repair and maintenance operations without complying with the procedures provided herein shall be responsible for any subsequent damages.

The manufacturer and all the organizations of its distribution chain, including - without limitation - national, regional, or local dealers, reject any responsibility for damages caused by parts and/or components not approved by the manufacturer, including those used for the servicing or repair of the product manufactured or marketed by the manufacturer. In any case, no warranty is given or attributed on the product manufactured or marketed by the manufacturer in case of damages caused by parts and/or components not approved by the manufacturer.

The information in this manual is up-to-date at the date of the publication. It is the policy of the manufacturer for continuous improvement. Some information could not be updated due to modifications of a technical or commercial type, or changes to the laws and regulations of different countries.

In case of questions, refer to your CASE CONSTRUCTION Sales and Service Networks.

Basic instructions - Shop and assembly

Shimming

For each adjustment operation, select adjusting shims and measure the adjusting shims individually using a micrometer, then add up the recorded values. Do not rely on measuring the entire shimming set, which may be incorrect, or the rated value shown on each shim.

Rotating shaft seals

For correct rotating shaft seal installation, proceed as follows:

1. Before assembly, allow the seal to soak in the oil it will be sealing for at least thirty minutes.
2. Thoroughly clean the shaft and check that the working surface on the shaft is not damaged.
3. Position the sealing lip facing the fluid.

NOTE: *With hydrodynamic lips, take into consideration the shaft rotation direction and position the grooves so that they will move the fluid towards the inner side of the seal.*

4. Coat the sealing lip with a thin layer of lubricant (use oil rather than grease). Fill the gap between the sealing lip and the dust lip on double lip seals with grease.
5. Insert the seal in its seat and press down using a flat punch or seal installation tool. Do not tap the seal with a hammer or mallet.
6. While you insert the seal, check that the seal is perpendicular to the seat. When the seal settles, make sure that the seal makes contact with the thrust element, if required.
7. To prevent damage to the seal lip on the shaft, position a protective guard during installation operations.

O-ring seals

Lubricate the O-ring seals before you insert them in the seats. This will prevent the O-ring seals from overturning and twisting, which would jeopardize sealing efficiency.

Sealing compounds

Apply a sealing compound on the mating surfaces when specified by the procedure. Before you apply the sealing compound, prepare the surfaces as directed by the product container.

Spare parts

Only use CNH Original Parts or CASE CONSTRUCTION Original Parts.

Only genuine spare parts guarantee the same quality, duration, and safety as original parts, as they are the same parts that are assembled during standard production. Only CNH Original Parts or CASE CONSTRUCTION Original Parts can offer this guarantee.

When ordering spare parts, always provide the following information:

- Machine model (commercial name) and Product Identification Number (PIN)
- Part number of the ordered part, which can be found in the parts catalog

Protecting the electronic and/or electrical systems during charging and welding

To avoid damage to the electronic and/or electrical systems, always observe the following practices:

1. Never make or break any of the charging circuit connections when the engine is running, including the battery connections.
2. Never short any of the charging components to ground.
3. Always disconnect the ground cable from the battery before arc welding on the machine or on any machine attachment.
 - Position the welder ground clamp as close to the welding area as possible.
 - If you weld in close proximity to a computer module, then you should remove the module from the machine.
 - Never allow welding cables to lie on, near, or across any electrical wiring or electronic component while you weld.
4. Always disconnect the negative cable from the battery when charging the battery in the machine with a battery charger.

NOTICE: *If you must weld on the unit, you must disconnect the battery ground cable from the machine battery. The electronic monitoring system and charging system will be damaged if this is not done.*

5. Remove the battery ground cable. Reconnect the cable when you complete welding.

Special tools

▲ WARNING

Battery acid causes burns. Batteries contain sulfuric acid.

Avoid contact with skin, eyes or clothing. Antidote (external): Flush with water. Antidote (eyes): flush with water for 15 minutes and seek medical attention immediately. Antidote (internal): Drink large quantities of water or milk. Do not induce vomiting. Seek medical attention immediately.

Failure to comply could result in death or serious injury.

W0111A

The special tools that CASE CONSTRUCTION suggests and illustrate in this manual have been specifically researched and designed for use with CASE CONSTRUCTION machines. The special tools are essential for reliable repair operations. The special tools are accurately built and rigorously tested to offer efficient and long-lasting operation.

By using these tools, repair personnel will benefit from:

- Operating in optimal technical conditions
- Obtaining the best results
- Saving time and effort
- Working in safe conditions

Safety rules

Personal safety





This is the safety alert symbol. It is used to alert you to potential personal injury hazards. Obey all safety messages that follow this symbol to avoid possible death or injury.

Throughout this manual you will find the signal words **DANGER**, **WARNING**, and **CAUTION** followed by special instructions. These precautions are intended for the personal safety of you and those working with you.

Read and understand all the safety messages in this manual before you operate or service the machine.

 **DANGER** indicates a hazardous situation which, if not avoided, will result in death or serious injury.

 **WARNING** indicates a hazardous situation which, if not avoided, could result in death or serious injury.

 **CAUTION**, used with the safety alert symbol, indicates a hazardous situation which, if not avoided, could result in minor or moderate injury.

FAILURE TO FOLLOW DANGER, WARNING, AND CAUTION MESSAGES COULD RESULT IN DEATH OR SERIOUS INJURY.

Machine safety

NOTICE: *Notice indicates a situation which, if not avoided, could result in machine or property damage.*

Throughout this manual you will find the signal word **Notice** followed by special instructions to prevent machine or property damage. The word **Notice** is used to address practices not related to personal safety.

Information

NOTE: *Note indicates additional information which clarifies steps, procedures, or other information in this manual.*

Throughout this manual you will find the word **Note** followed by additional information about a step, procedure, or other information in the manual. The word **Note** is not intended to address personal safety or property damage.

Product identification - Machine components

Left-hand side

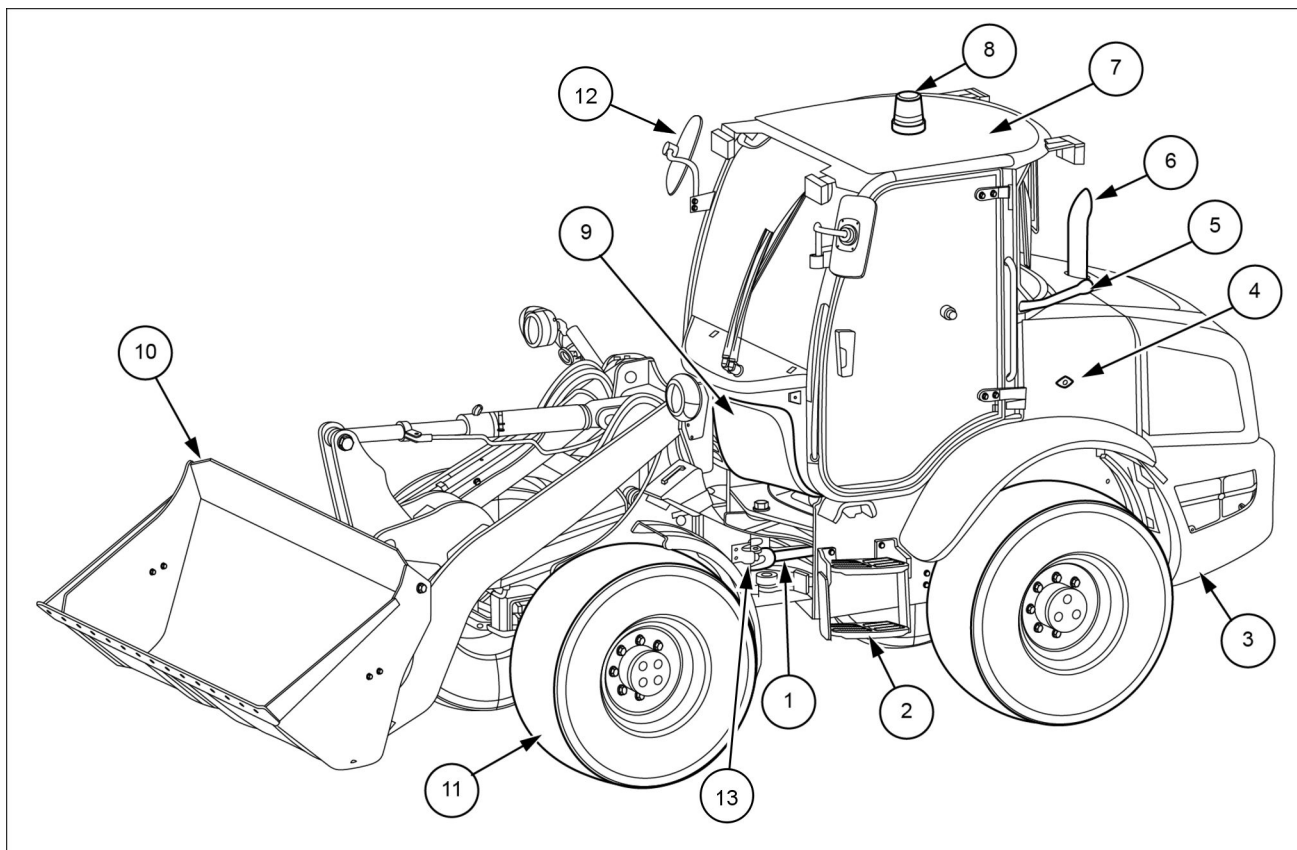

LEIL15CWL0334FB 1

- | | |
|---|-----------------------------|
| 1. Steering cylinder | 8. Rotary beacon (optional) |
| 2. Access steps to cab (one step for 21F and 121F) | 9. Cab air filter access |
| 3. Counterweight | 10. Bucket |
| 4. Fuel tank and engine coolant reservoir access | 11. Wheels |
| 5. Cab door locking pin | 12. Mirrors |
| 6. Final tail | 13. Transport safety pin |
| 7. Roll Over Protection Structure (ROPS) and Falling Objects Protective Structure (FOPS) cab (standard or deluxe cab) | |

Right-hand side

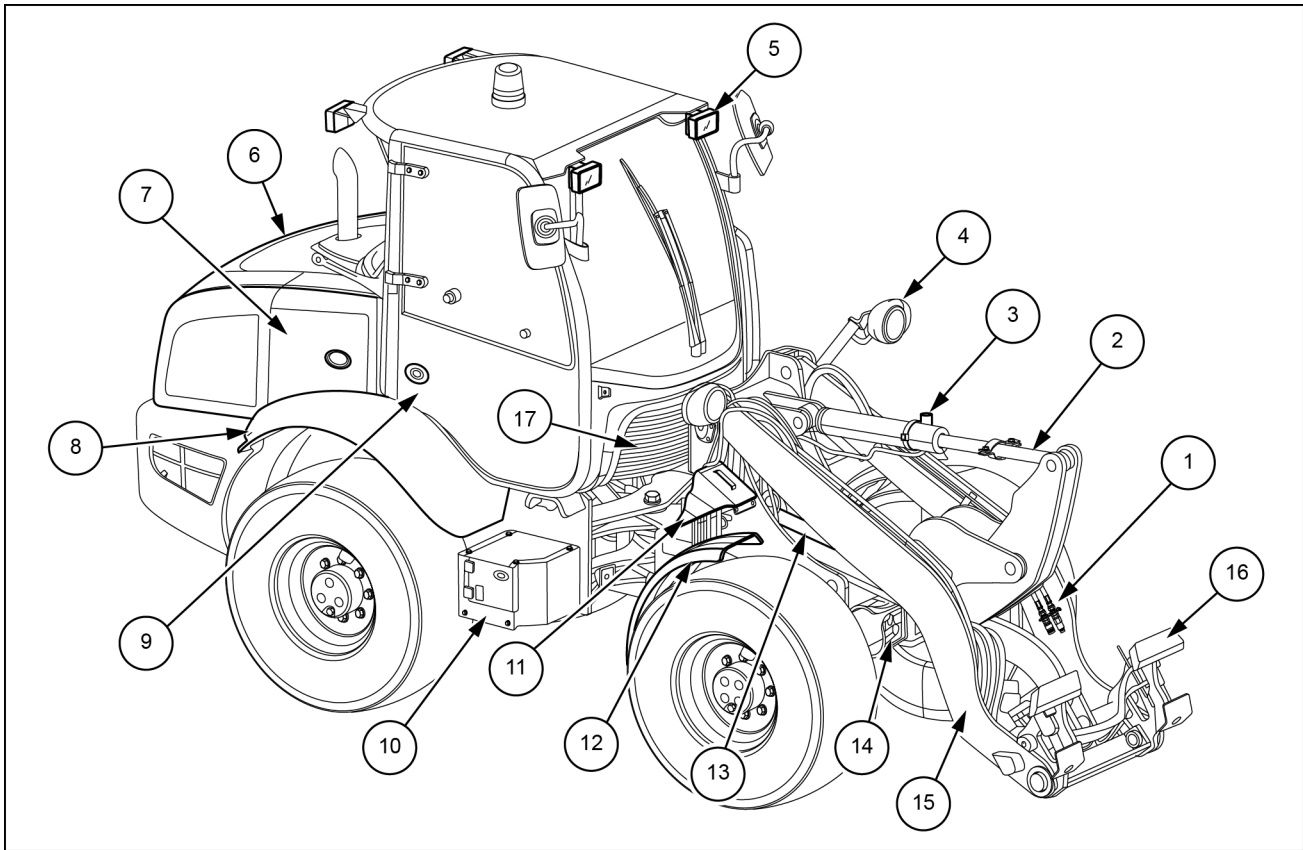

LEIL15CWL0305FB 2

- | | |
|------------------------------------|---|
| 1. High Flow (optional) | 10. Battery compartment |
| 2. Tilt cylinder | 11. Wheel chocks |
| 3. Return-to-dig (optional) | 12. Front fender |
| 4. Driving lights | 13. Lift cylinders |
| 5. Work lights (optional) | 14. Axles |
| 6. Engine hood | 15. Lift arm |
| 7. Hydraulic oil tank access panel | 16. Quick Coupler (Skid Steer Loader version) |
| 8. Rear fender | 17. Brake oil tank access panel |
| 9. Fuse and relay access | |

18. 3rd hydraulic function (Horizontal Pin version)
 19. 4th hydraulic function (Horizontal Pin version)

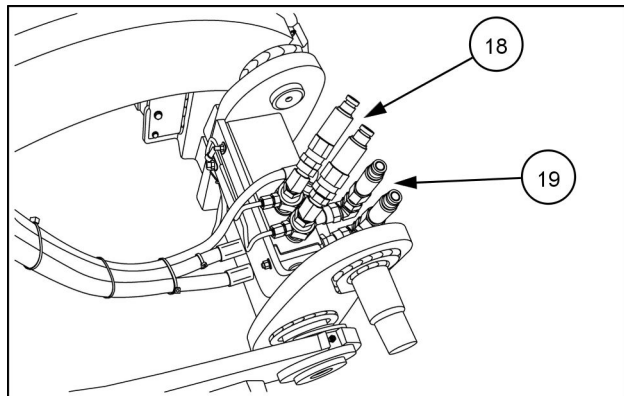

LEIL15CWL0101AA 3



SERVICE MANUAL

Engine

121F XT, 121F ZB, 21F XT, 21F ZB, 221F HS, 221F STD, 321F HS, 321F STD

Engine - Remove

NOTE: Emissions sensors mounted in the exhaust stream are sensitive to extreme vibrations. Use of tools that generate extreme vibrations, such as impact wrenches and hammers, will result in damage to emission sensors. Avoid using these tools during any service procedure in close proximity of emission sensors. If the use of these tools cannot be avoided, remove the sensors using extreme caution prior to performing any service procedure.

1. Park the machine on firm, level ground, lower the bucket/attachment to the ground.
Drive the machine into such a position that the bores of the holders are aligned one above the other. Then secure with the pin (arrow). The pin is located inside the support on the frame.
Stop the engine.

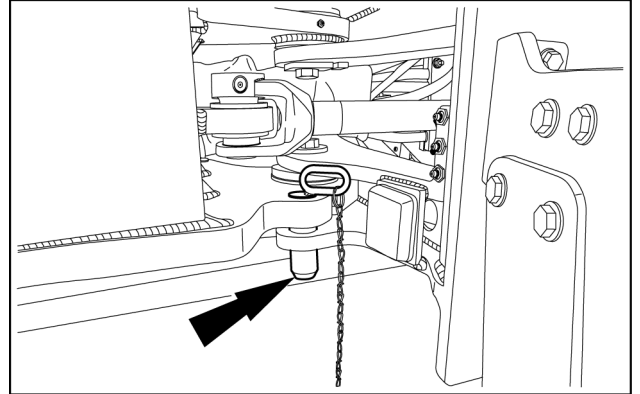

LEIL14CWL0005AB 1

2. Keep all non-authorized personnel clear of the machine. Turn the ignition switch key to the "ON" position.
3. Move the joystick slowly forward and backward and from the right-hand to the left-hand approximately a dozen times. Turn the ignition key to the OFF position.

NOTE: before carrying out any service work on the hydraulic system, it is necessary to allow the system to cool: the temperature should not be more than **40 °C (104.0 °F)**.

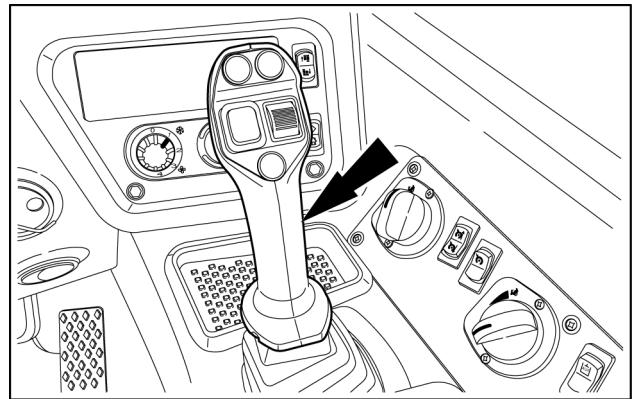

LEIL14CWL0003AB 2

4. Open the outer panel to access the battery main switch. The battery main switch box is located on the right-hand side of the machine, below the operator's compartment.

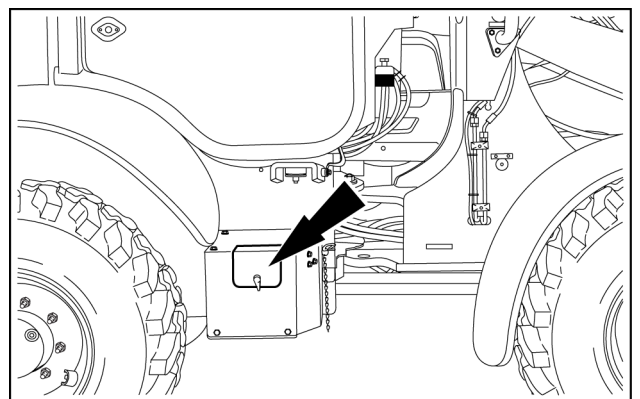

LEIL14CWL0015AB 3

- Put the battery main switch **(1)** in the OFF position.

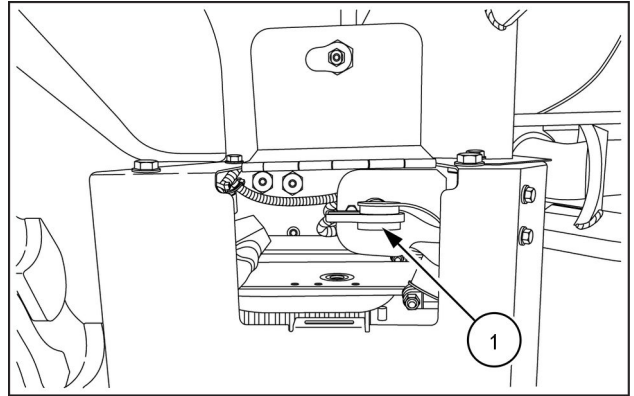

LEIL14CWL0017AA 4

- Disconnect the wiring harness (X-228) and (X-229) from the engine air filter. Disconnect the wiring harness (X-106) from the air temperature sensor.

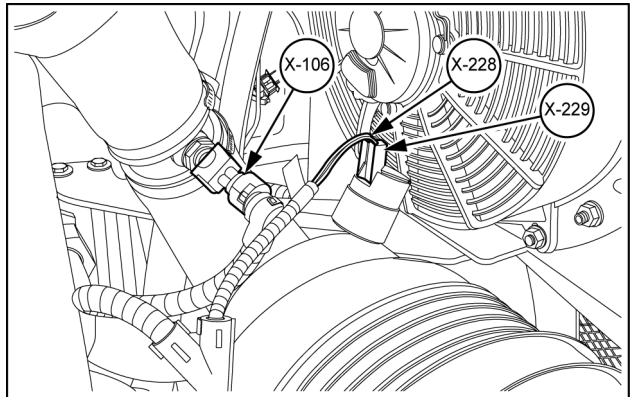

LEIL14CWL0171AB 5

Versions with air conditioning

- Drain the air conditioning system and disconnect the fan electrical connector **(1)**. Tag and disconnect the condenser hoses **(2)** and **(3)**.

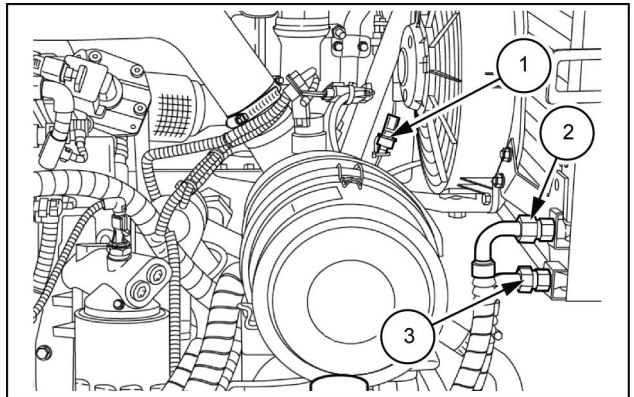

LEIL14CWL0159A 6

- Remove the two lower bolts **(1)** of the condenser bracket **(2)**.

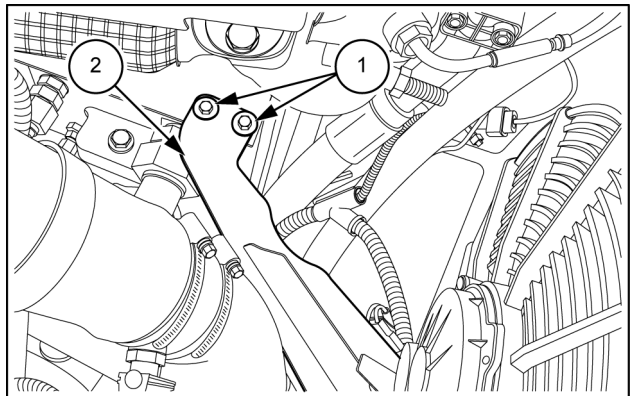

LEIL14CWL0160AB 7

3. Remove the two upper bolts (1) of the condenser.
Remove the condenser (2).

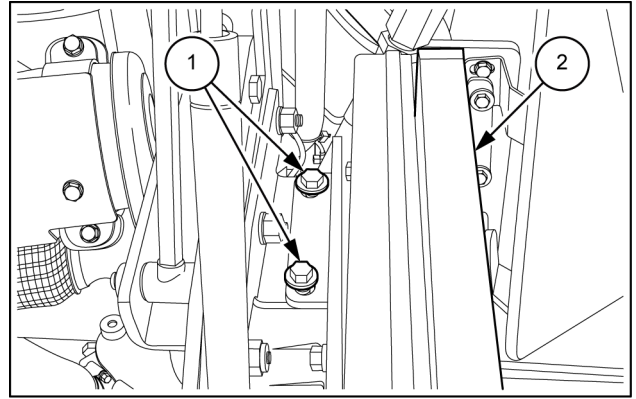

LEIL14CWL0161AB 8

All versions

1. Secure the engine hood (1) with the nylon lifting strap.

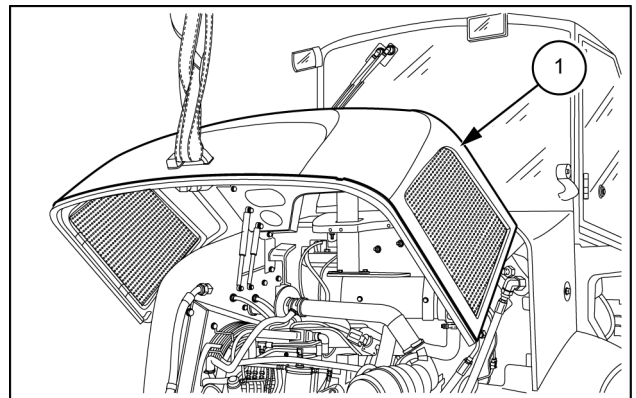

LEIL14CWL0216AB 9

2. Have another person to balance the hood and remove the hood hinge mounting bolts (arrows) from the machine structure.
Carefully raise and remove the engine hood (1) from loader. Lower the engine hood onto suitable platform and disconnect lifting equipment.

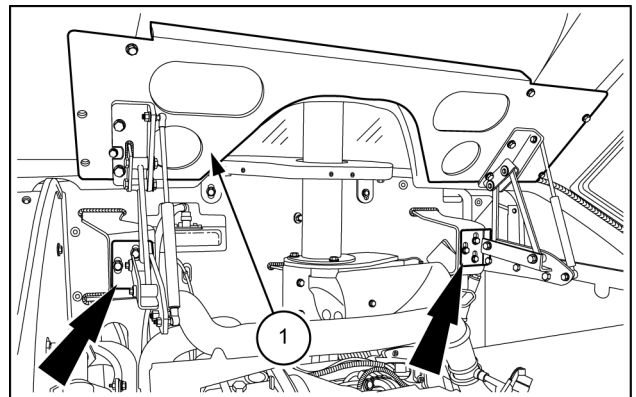

LEIL14CWL0162AB 10

3. Tag and disconnect the left rear light connector (1).
Repeat this operation for the right rear light connector.

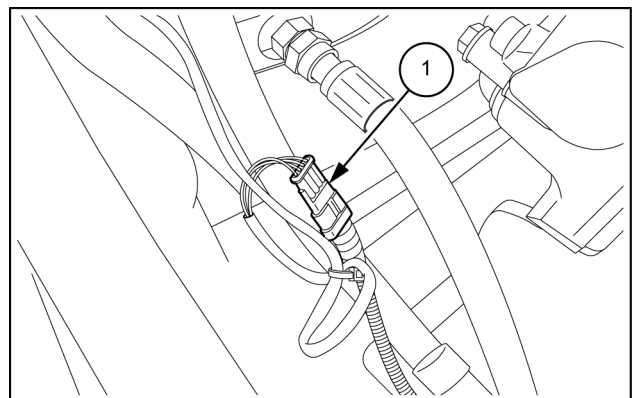

LEIL14CWL0163AB 11

4. Tag and disconnect the water in fuel wiring harness (X-105).
Tag and disconnect the backup alarm wiring harness (X-064).
Tag and disconnect the filter pressure switch wiring harness (X-227). Cut the ties cable (1).

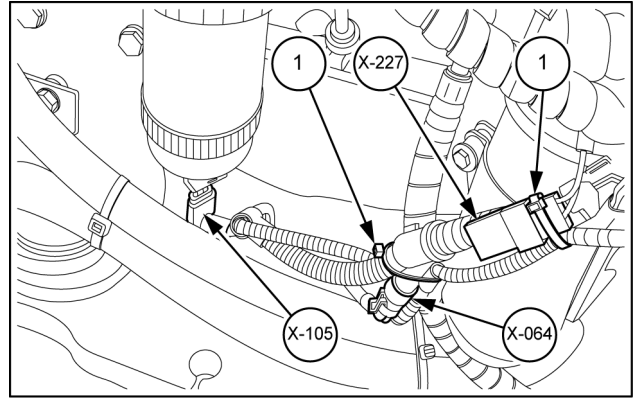

5. Remove the four mounting bolts (1) of the right grid (2).
Remove the right grid (2).

NOTE: repeat the same operation on the left side.

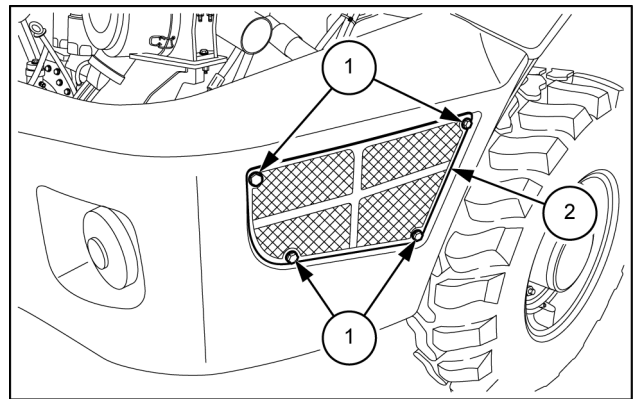

6. Connect suitable lifting equipment to counterweight (refer to Counterweight – Remove).
Remove the six bolts (arrows) of the counterweight and remove it.

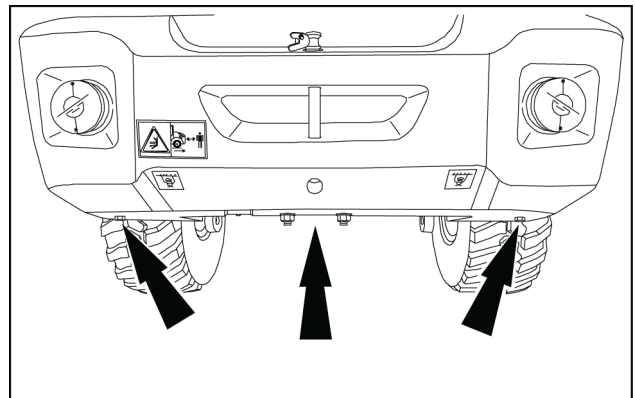

7. Slowly extract the counterweight (1) from rear chassis.
Be sure all wire harness connections have been disconnected.
Remove the counterweight (1) from the machine.
Lower the counterweight onto suitable platform and disconnect the lifting equipment.

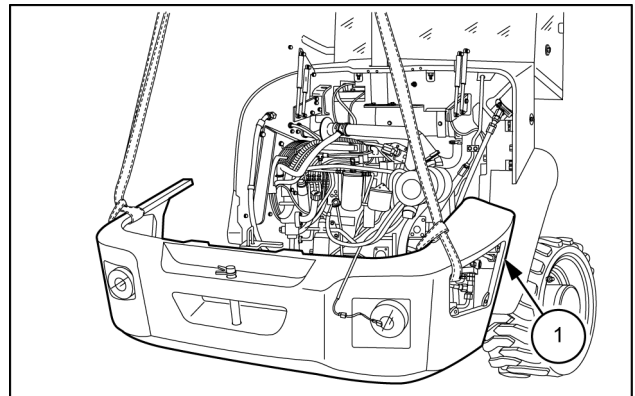

8. Remove the cap from the hydraulic tank (2).
Insert, into the hole, the hose (1) connected to a suction pump and suck the oil from the tank (2).

NOTE: use a suitable container for collection of coolant and abide by all local environmental laws for proper handling and disposal.

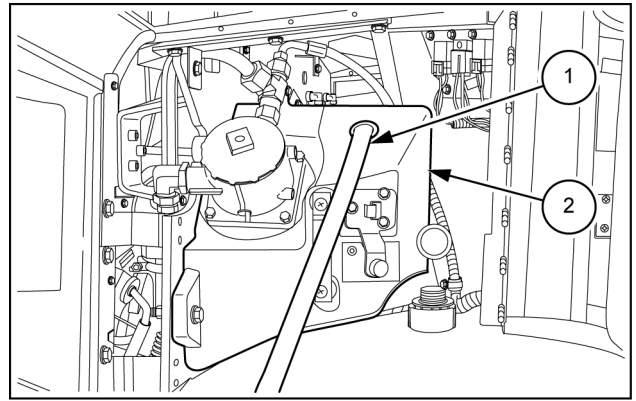

LEIL14CWL0219AB 16

9. Loosen the clamp (2) on the coolant hose (1) and disconnect it from the radiator.

NOTE: use a suitable container for collection of coolant and abide by all local environmental laws for proper handling and disposal.

10. Unscrew the fitting and disconnect the hydraulic oil hose (3) from the radiator.

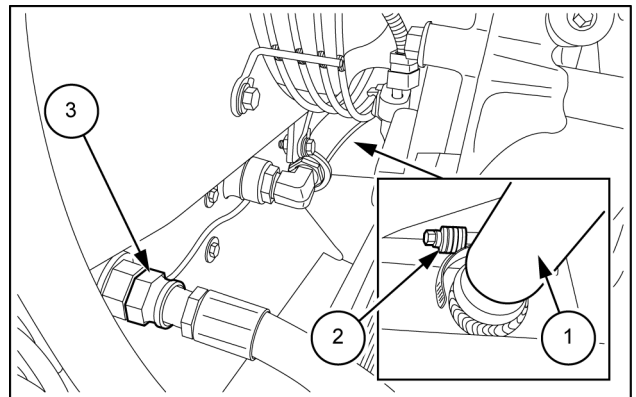

LEIL14CWL0232AB 17

11. Loosen the clamp (1) and disconnect the coolant hose (2) from the radiator.
Unscrew the fitting and disconnect the hydraulic oil hose (3) from the radiator.

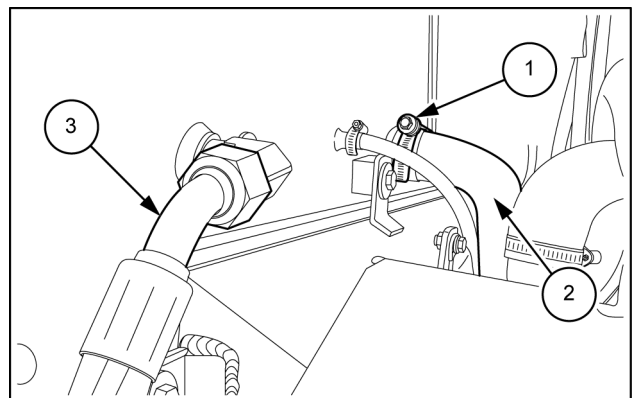

LEIL14CWL0233AB 18

12. Remove the screws (1) securing the clamps of the hydraulic oil hose (2).

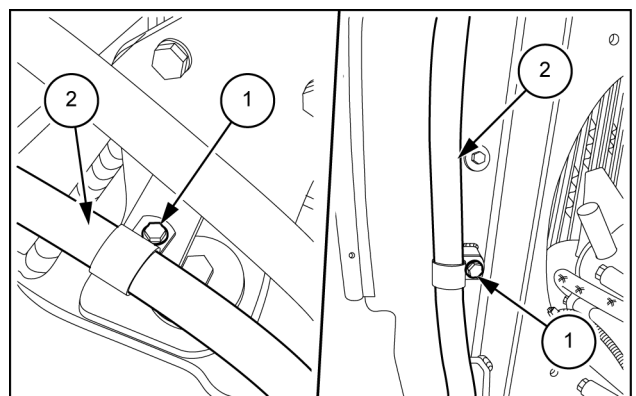

LEIL14CWL0234AB 19

13. Remove the four screws **(1)** to remove the fan guard **(2)**.

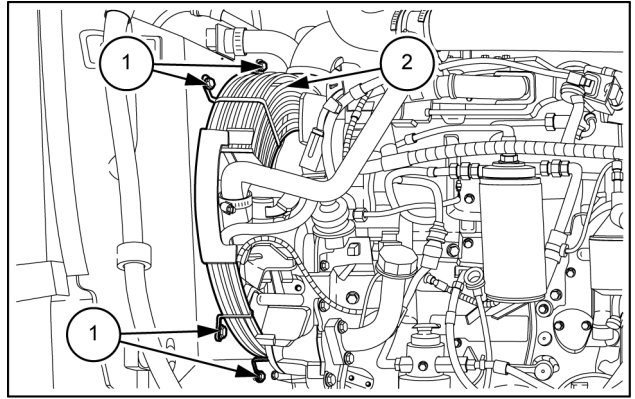

LEIL14CWL0469AB 20

14. Loosen the nut **(3)** to unscrew the fan **(4)**.
The nut **(3)** is left-handed: turn the nut **(3)** clockwise in respect to the engine to loosen the nut **(3)**.

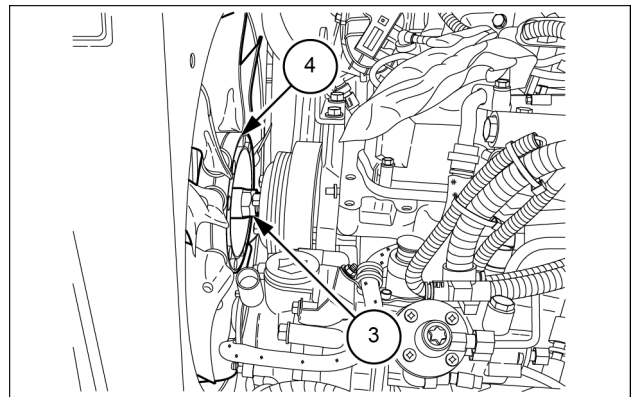

LEIL14CWL0456AB 21

15. Lean the fan **(4)** against the radiator group **(5)**.

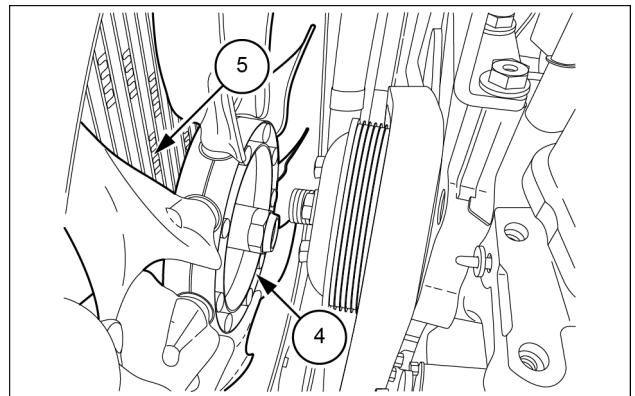

LEIL14CWL0457AB 22

16. Remove the screw **(1)** and disconnect the earth strap **(2)** from the engine.

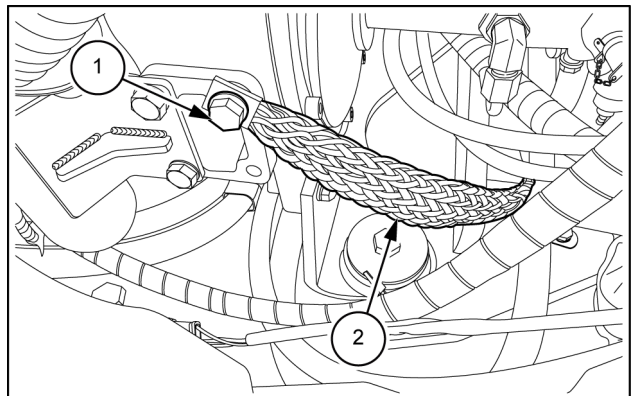

LEIL14CWL0170AB 23

17. Loosen the clamp **(1)** and disconnect the oil steam recovery hose **(2)**.

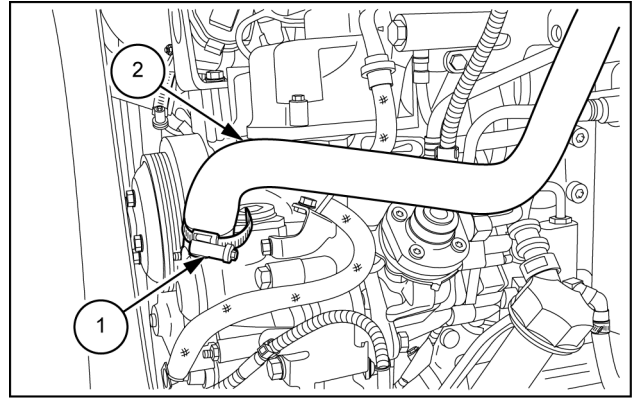

LEIL14CWL0220AB 24

18. Loosen the clamp **(1)** and disconnect the air inlet hose **(4)**.
Remove the screws **(2)** from the bracket **(3)**.

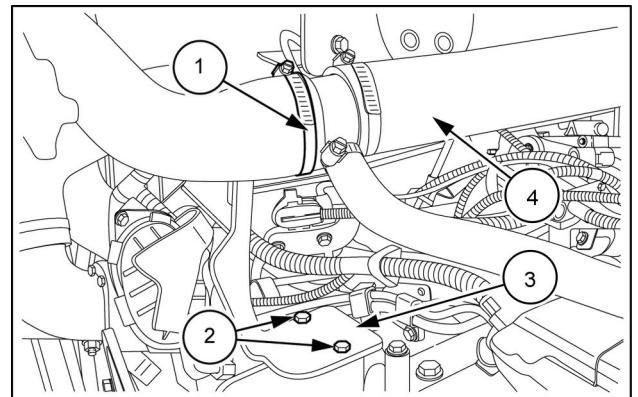

LEIL14CWL0221AB 25

19. Remove the screw **(2)** to release the air inlet hose **(3)** from the clamp **(1)**.

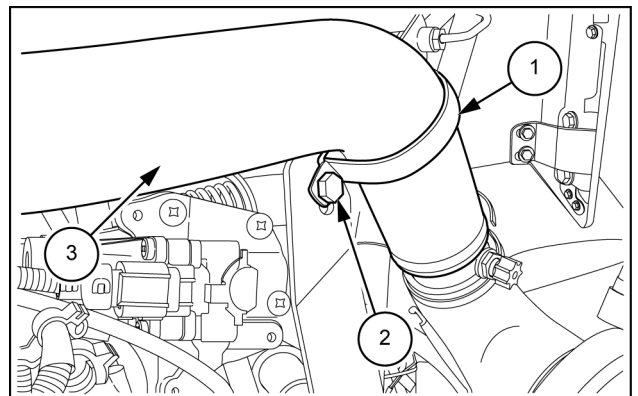

LEIL14CWL0222AB 26

20. Remove the screw **(2)** of the half guideway **(3)** for positioning fuel hoses **(1)**.

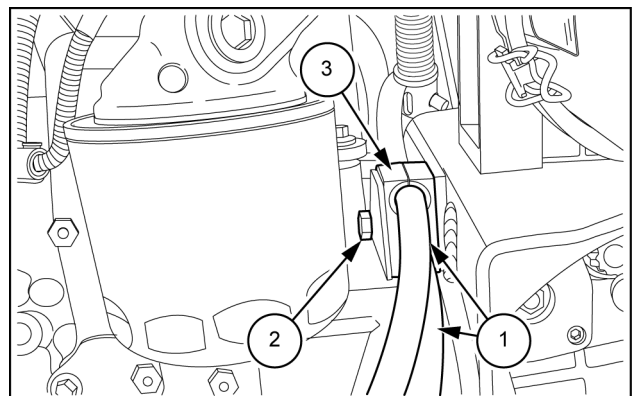

LEIL14CWL0223AB 27

21. Remove the screws **(1)** of the air filter bracket **(2)**.
Remove the air filter assembly **(3)** with the air inlet hose, the oil vapor recovery pipe and bracket with O-ring.

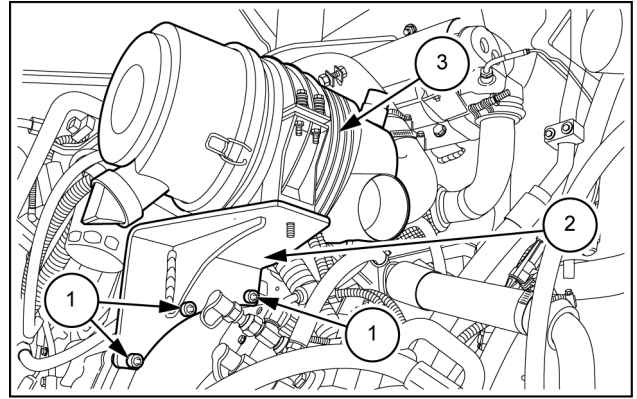

LEIL14CWL0224AB 28

22. Disconnect the wiring harness (X-109) from the intermediate connector signal.
Disconnect the wiring harness (X-110) from the intermediate connector injector.
Disconnect the A/C clutch wiring harness (X-226) (only air conditioning versions).
Remove the clamp **(1)** and cut the ties cable **(2)**.

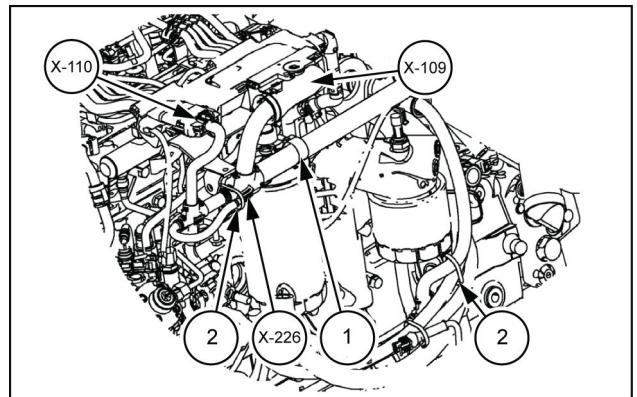

LEIL14CWL0172A 29

23. Behind the starter motor **(1)**, remove the screw **(3)** and disconnect the ground wiring harness (X-232), (X-233) and (X-234).
Remove the ties cable **(2)**.

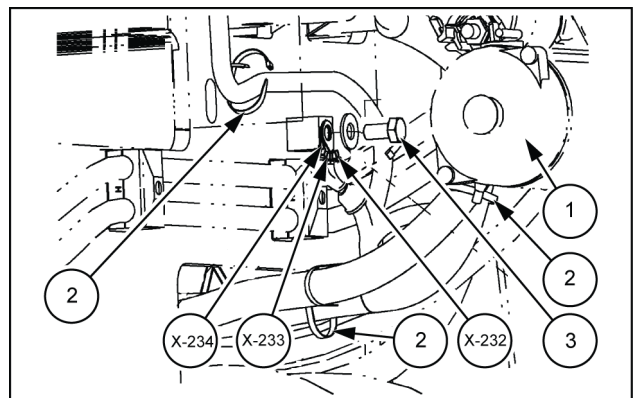

LEIL14CWL0174AB 30

24. Fan condenser connector (X-056) has already been disconnected when removing the condenser (only air conditioning versions).
 Disconnect reverse solenoid wiring harness (X-086).
 Disconnect the forward solenoid wiring harness (X-087).
 Disconnect the exhaust gas temperature sensor wiring harness (X-107) and (X-108).
 Remove the ties cable (1).

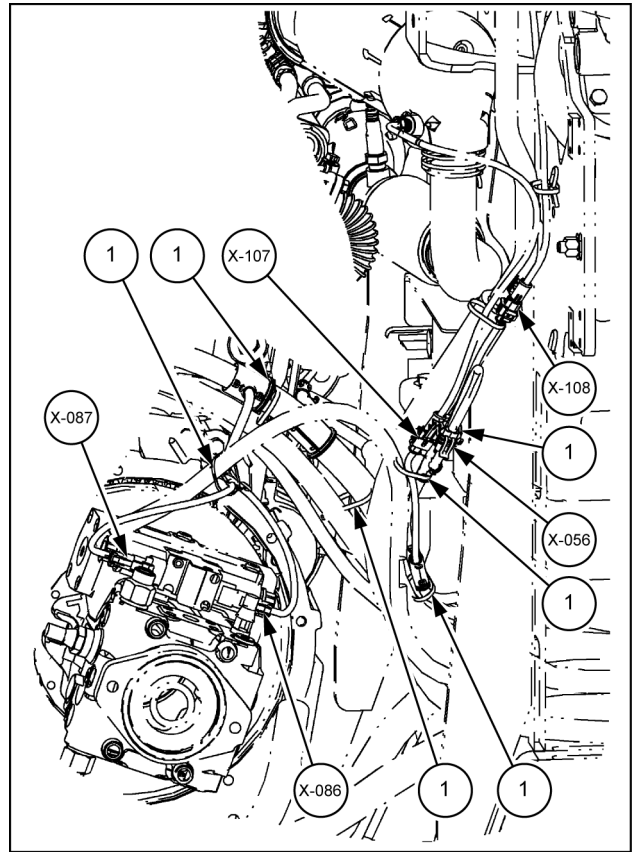

LEIL14CWL0175BB 31

25. Remove the screws (1) securing the exhaust stack (2).
NOTE: the exhaust stack (2) must be removed after the detachment of the PM-Cat system.

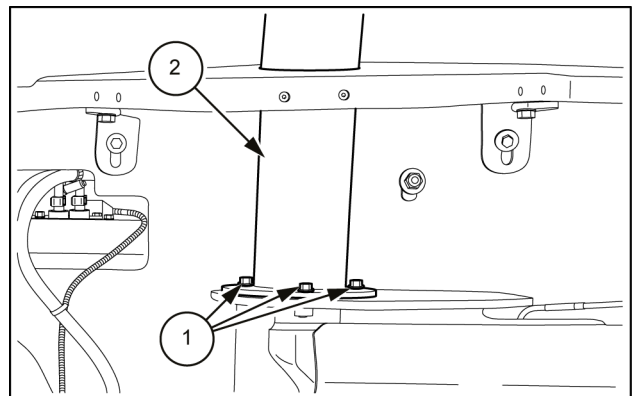

LEIL14CWL0225AB 32

26. Loosen the clamp (1) and disconnect the compensation hose (2) from the PM-Cat system (3).

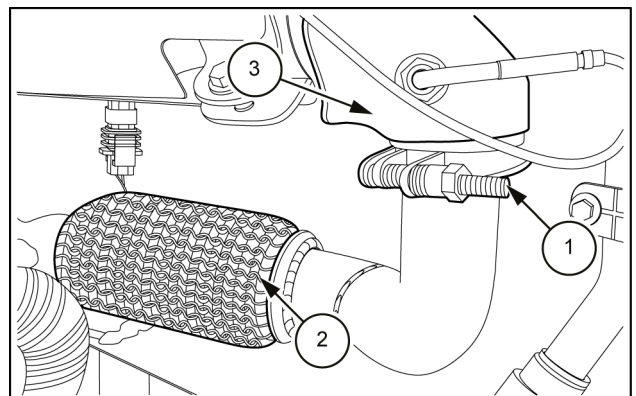

LEIL14CWL0226AB 33

27. Remove the four screws (arrows) securing PM-Cat system (1) of the frame.
Remove the PM-Cat system (1) from the machine.
Extract, from the bottom, the exhaust stack.

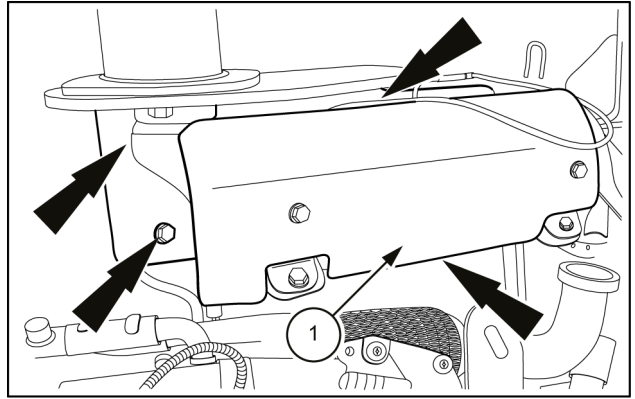

LEIL14CWL0227AB 34

28. Disconnect the lambda probe connector (2).
Loosen the clamp (1) and remove the compensation hose (3) from the turbocharger (4).

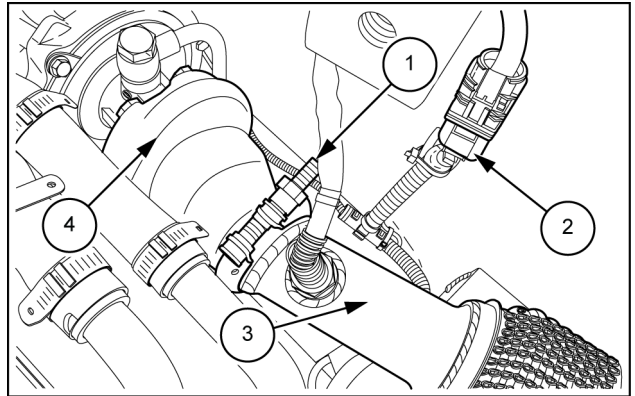

LEIL14CWL0228AB 35

29. Acting from under the machine:

- turn off the tap (1);
- loosen the clamp (2) and disconnect the cab heating hose;
- open the tap (1) to drain the coolant from the engine block.

NOTE: use a suitable container for collection of coolant and abide by all local environmental laws for proper handling and disposal.

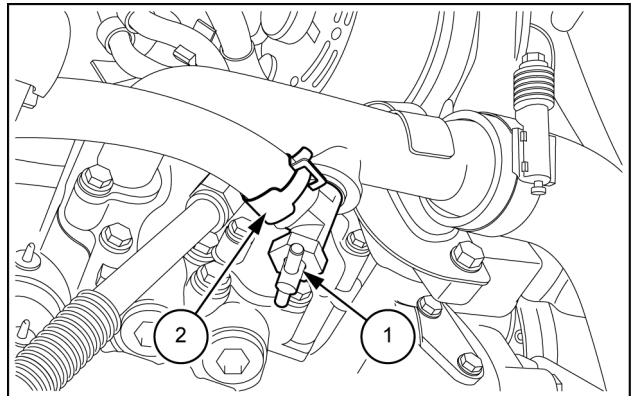

LEIL14CWL0229AB 36

30. From the right side of the machine, loosen the clamp (1) and disconnect the hose cab heating (2).

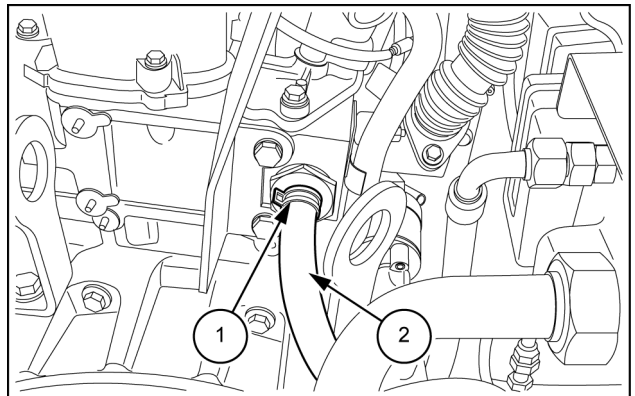

LEIL14CWL0230AB 37

31. Remove the screw (1) of the half guideway for positioning reverse hose (2) and forward hose (3).

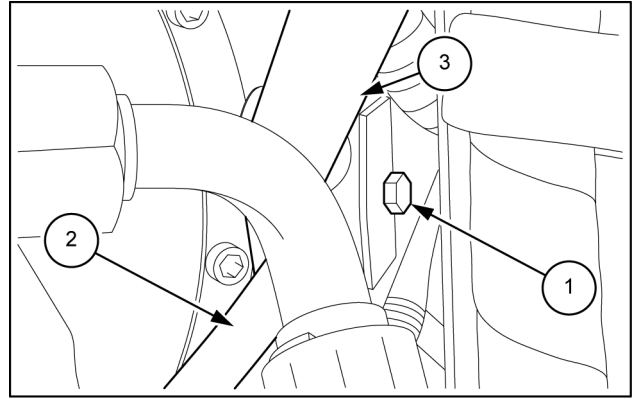

LEIL14CWL0231AB 38

32. Tag and disconnect starter motor (Terminal 50) wiring harness (X-061).
 Tag and disconnect starter motor wiring harness (X-062) and (X-063).
 Tag and disconnect alternator battery cable (X-040).
 Tag and disconnect alternator (D+) wiring harness (X-041).
 Unscrew the bolt (1) and remove the clamp (2).
 Remove eventually clamps and cut the ties cable not indicated.

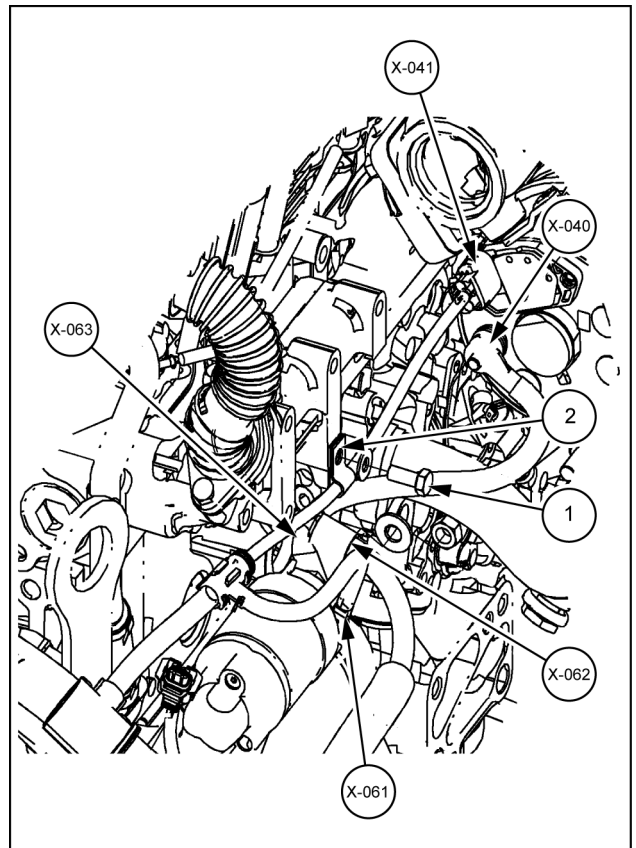

LEIL14CWL0176BB 39

33. Disconnect the fuel line hose (1) from the fuel pre-filter and fuel hose (2).

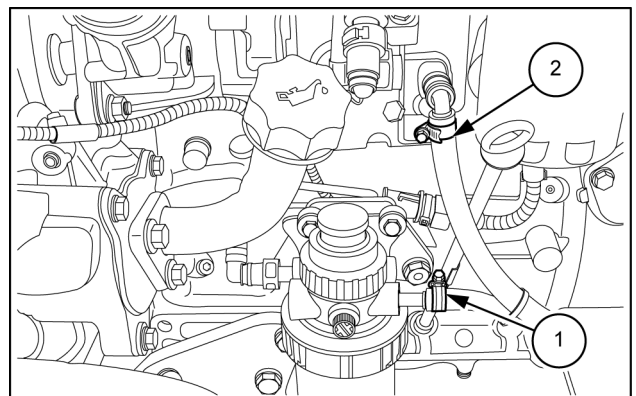

LEIL14CWL0177AB 40

34. Unscrew the hydraulic fitting (1), (2) and (3) and disconnect the hoses from the gear pump. Unscrew the hydraulic fitting (5) and (6) and disconnect the hoses from the hydrostatic pump. Remove the four screws and disconnect the pipe (4) from the hydrostatic pump. Unscrew the hydraulic fitting (7) and disconnect the pipe from the hydrostatic pump.

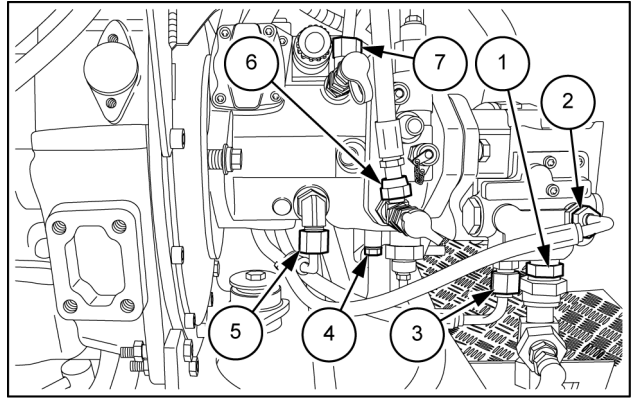

LEIL14CWL0178AB 41

35. Unscrew the hydraulic fitting (1) and disconnect the hose from the hydrostatic pump. Unscrew the hydraulic fitting (2) and disconnect the pipe from the hydrostatic pump. Remove the four screws and disconnect the pipe (4) from the hydrostatic pump. Remove the four screws and disconnect the pipe (3) from the gear pump.

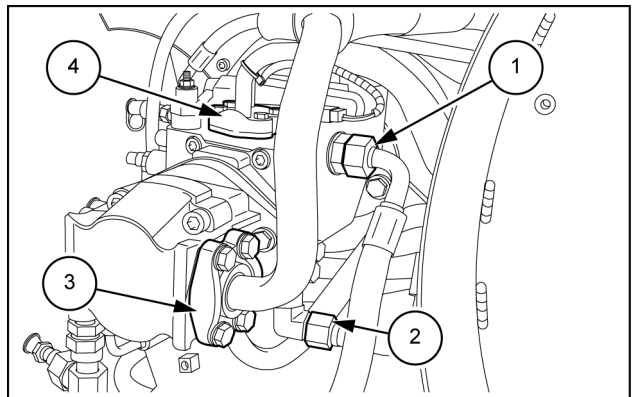

LEIL14CWL0179AB 42

36. For the models equipped with auxiliary pump (1), unscrew the hydraulic fitting (2) and disconnect the hose from the auxiliary pump.

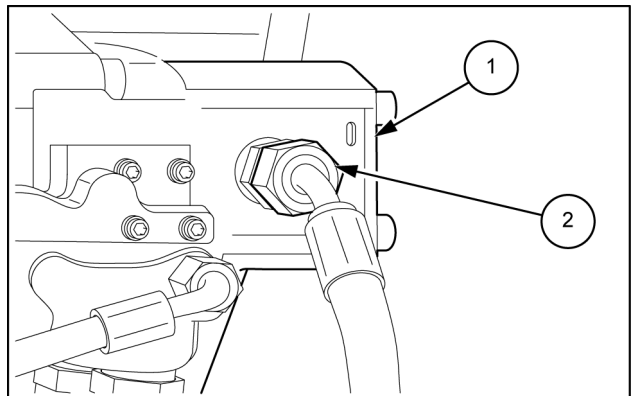

LEIL14CWL0180AB 43

37. Connect suitable lifting equipment to engine lifting brackets (arrows). Take up all slack in lifting equipment.

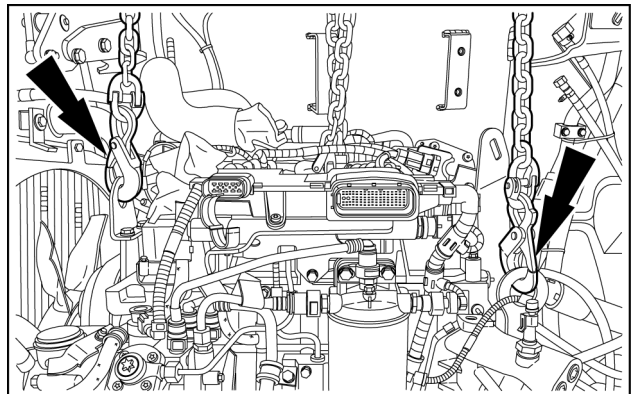

LEIL14CWL0236AB 44

38. Remove the engine silent block (arrows) unscrewing the nuts from the lower part of the engine. Slowly raise engine from rear chassis. Be sure all wire harness connections and hoses have been disconnected and are clear of the engine. Remove engine from machine.

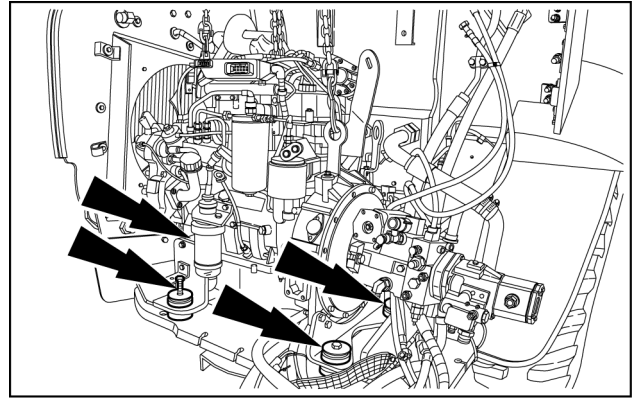

LEIL14CWL0235AB 45

Engine - Install

⚠ WARNING

Hot liquid under pressure!

Never remove the filler cap or the recovery tank cap while the engine is running or the coolant is hot. Let the system cool. Turn the filler cap to the first notch and allow any pressure to escape, and then remove the filler cap. Loosen the recovery tank cap slowly to allow any pressure to escape. Failure to comply could result in death or serious injury.

W0296A

NOTE: Emission sensors mounted in the exhaust stream are sensitive to extreme vibrations. Use of tools that generate extreme vibrations, such as impact wrenches and hammers, will result in damage to emission sensors. Avoid using these tools during any service procedure in close proximity of emission sensors. If the use of these tools cannot be avoided, remove the sensors using extreme prior to performing any service procedure.

1. Inspect the engine mounts. If the engine rubber isolators require replacement, remove and discard the isolators (1) and (2). Install new rubber isolator (2), then rubber isolator (1).

Make sure that the tightening torque of the fixing screws of the brackets to the engine is **118 – 133 N·m (87 – 98 lb ft)**.

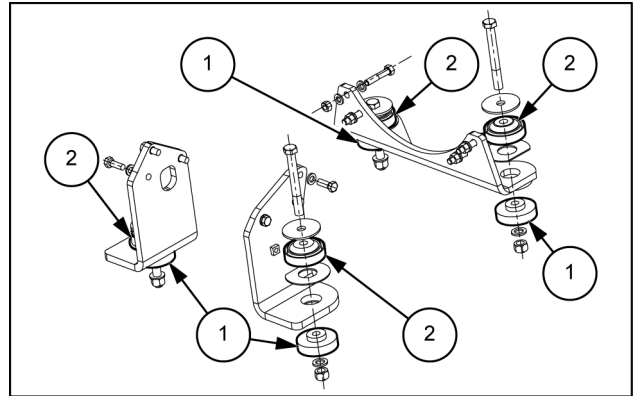

LEIL14CWL0393AB 1

2. Attach suitable lifting device to the engine and slowly move it into position over the rear chassis. Be sure all harness connections and hoses are out of the way or positioned correctly for reconnecting, before lowering engine.

Install the silent blocks (arrows) on the engine.

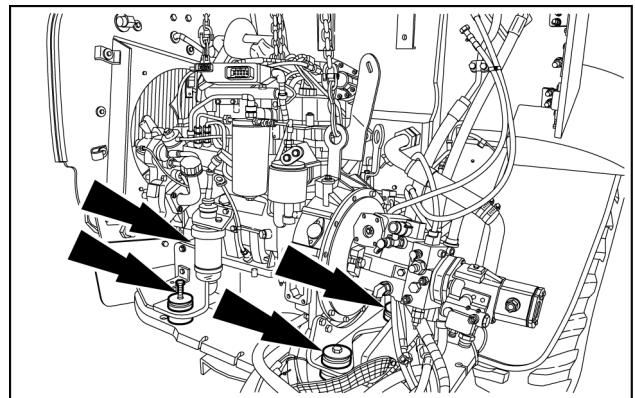

LEIL14CWL0235AB 2

3. Tighten the mounting bolts of the engine to a torque of **244 – 298 N·m (180 – 220 lb ft)**.

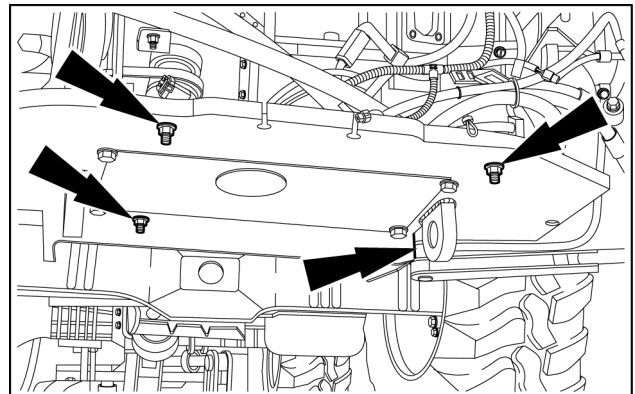

LEIL14CWL0394AB 3

4. Disconnect lifting equipment from the engine lifting brackets.

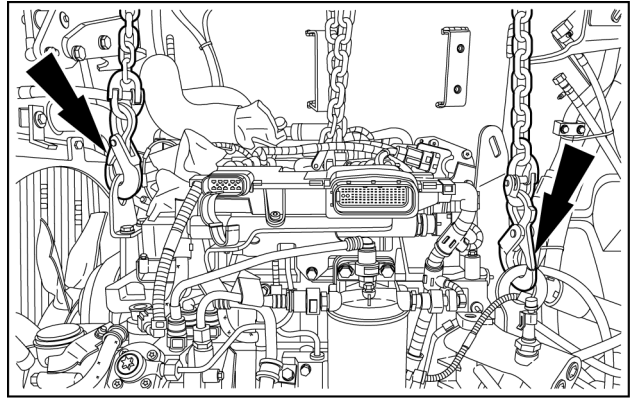

LEIL14CWL0236AB 4

5. For the models equipped with auxiliary pump (1), connect the hydraulic hose to the auxiliary pump and tighten the fitting (2).

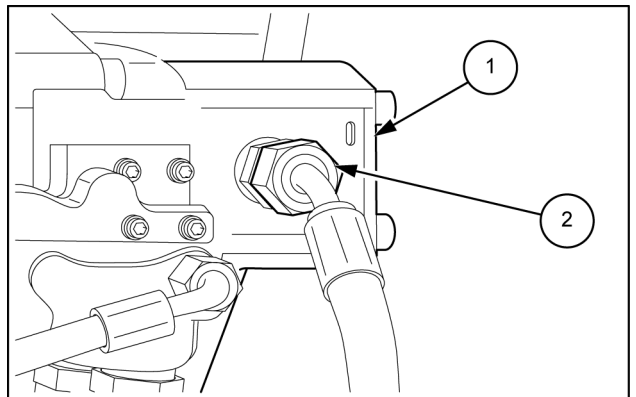

LEIL14CWL0180AB 5

6. Connect the hydraulic pipe (3) to the gear pump and tighten the four screws on the half-shells. Connect the hydraulic pipe (4) to the hydrostatic pump and tighten the four screws on the half-shells. Connect the hydraulic hoses to the hydrostatic pump and tighten the fittings (1) and (2).

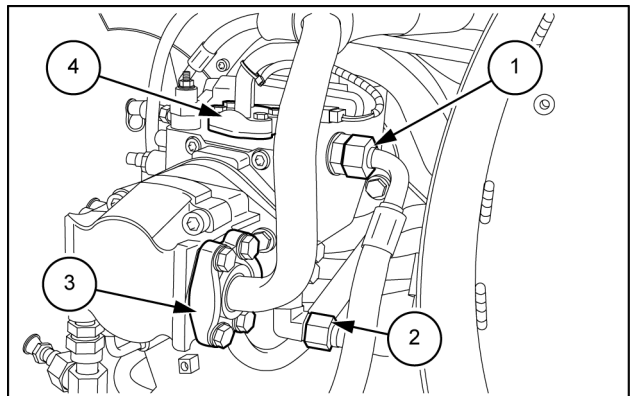

LEIL14CWL0179AB 6

7. Connect the hydraulic hoses to the gear pump and tighten the fittings (1), (2) and (3). Connect the hydraulic hoses to the hydrostatic pump and tighten the fittings (5) and (6). Connect the hydraulic pipe (4) to the hydrostatic pump and tighten the four screws of the half-shells. Connect the hydraulic pipe to the hydrostatic pump and tighten the fitting (7).

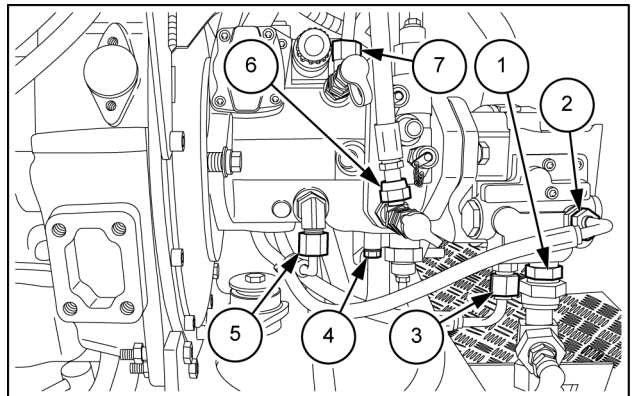

LEIL14CWL0178AB 7

8. Connect the fuel line hose (1) to the fuel pre-filter and fuel hose (2).

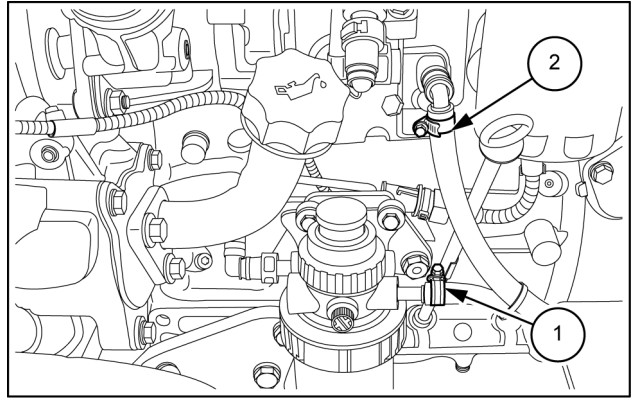

LEIL14CWL0177AB 8

9. Connect starter motor (Terminal 50) wiring harness (X-061).
 Connect starter motor wiring harness (X-062) and (X-063).
 Connect alternator battery cable (X-040).
 Connect alternator (D+) wiring harness (X-041).
 Install the clamp (2) and secure it with the bolt (1).

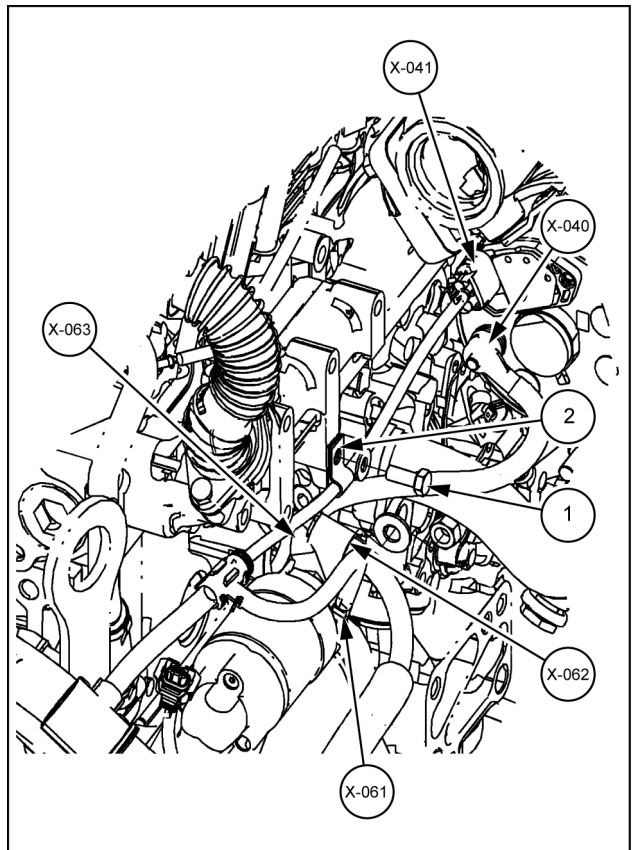

LEIL14CWL0176BB 9

10. Remove the screw (1) of the half guideway for positioning reverse hose (2) and forward hose (3).
 Position the half guideway on the reverse hose (2) and forward hose (3).
 Tighten the screw (1) for blocking the hoses in correctly position.

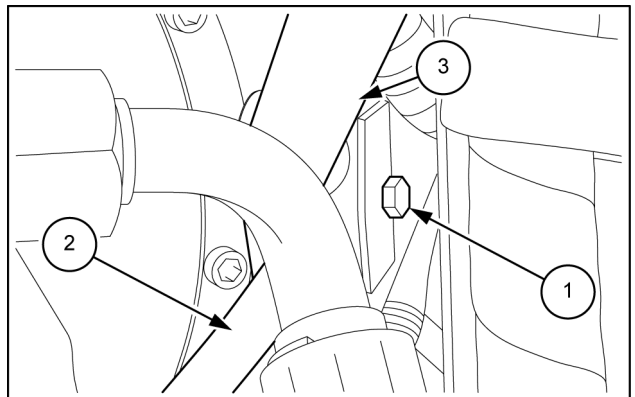

LEIL14CWL0231AB 10

11. From the right side of the machine, connect the hose cab heating (2) to the engine and secure the clamp (1).

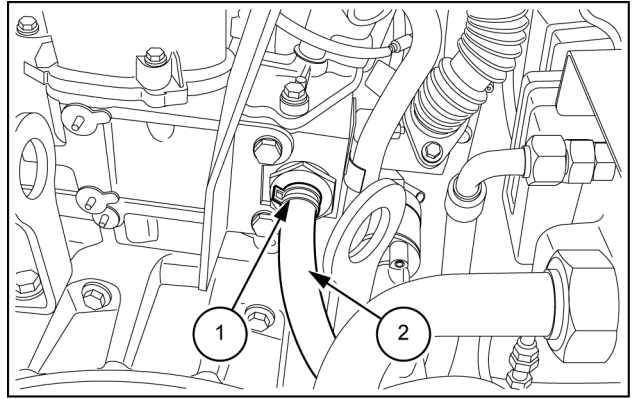

LEIL14CWL0230AB 11

12. Acting from under the machine:
- connect the cab heating hose and secure the clamp (2);
 - open the tap (1).

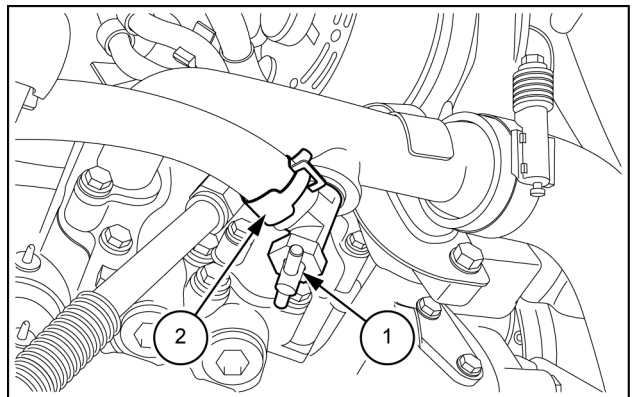

LEIL14CWL0229AB 12

13. Install the compensation hose (3) on the turbocharger (4). Tighten the collar (1). Connect the lambda probe connector (2).

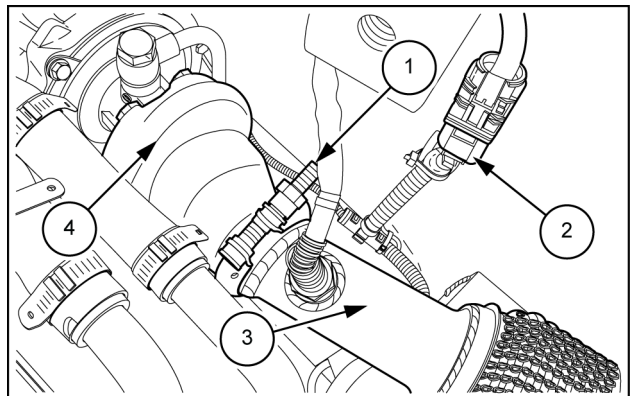

LEIL14CWL0228AB 13

14. Insert, from the bottom, the exhaust stack. Install the PM-Cat system (1) on the machine. Tighten the four screws (arrows) to secure the PM-Cat system (1) to the frame.

NOTE: the exhaust stack must be positioned before the installation of the PM-Cat system.

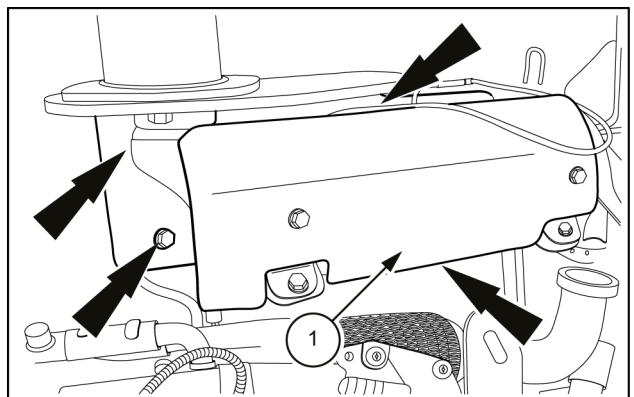

LEIL14CWL0227AB 14



Suggest:

If the above button click is invalid.

Please download this document

first, and then click the above link

to download the complete manual.

Thank you so much for reading

15. Connect the compensation hose (2) to the PM-Cat system (3).
Tighten the collar (1).

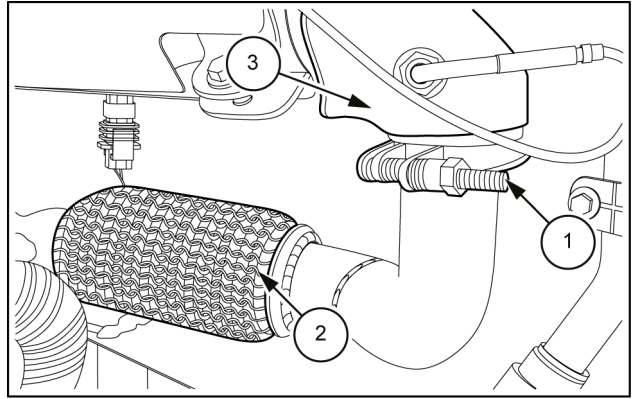

LEIL14CWL0226AB 15

16. Install the exhaust stack (2) on the PM-Cat system and tighten the screws (1).

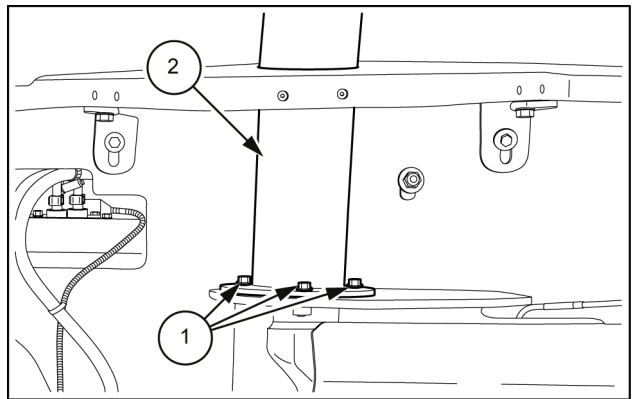

LEIL14CWL0225AB 16

17. Connect the exhaust gas temperature sensor wiring harness (X-107) and (X-108).
Connect the forward solenoid wiring harness (X-087).
Connect reverse solenoid wiring harness (X-086).
Secure the wiring harness with the ties cable (1).

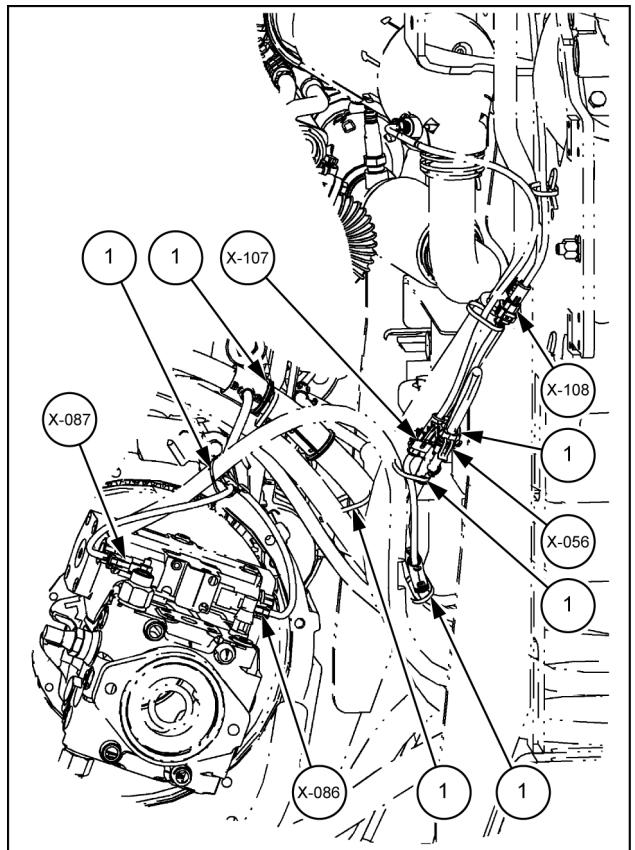

LEIL14CWL0175BB 17

<https://www.ebooklibonline.com>

Hello dear friend!

Thank you very much for reading.

Enter the link into your browser.

The full manual is available for immediate download.

<https://www.ebooklibonline.com>