



21B - 121B - 221B Loaders

Table of contents

DIVISION/SECTION	SECTION No.	REFERENCE No.
1 GENERAL INFORMATION		
Safety, General Information and Torque Settings.....	1001	7-57890GB
Specifications:		
21B loader	1002	7-57900GB
Specifications:		
121B loader: up to Serial Number DAH 1218599		
221B loader: up to Serial Number DAH 2218599.....	1002	7-58160GB and 7-58160R1GB
Specifications:		
121B loader: Serial Number DAH 1218600 and after		
221B loader: Serial Number DAH 2218600 and after.....	1002	7-84250GB
2 ENGINE		
Engine Specifications.....	2401	7-57910GB
Cylinder Head and Valve Assembly	2415	7-57920GB
Cylinder Block	2425	7-57930GB
Lubrication System	2445	7-57940GB
Cooling System.....	2455	7-57950GB
Turbocharger.....	2465	7-57960GB
3 FUEL SYSTEM		
Fuel System and Filter	3410	7-57970GB
Injection Pump	3412	7-57980GB
4 ELECTRICAL SYSTEM		
Electrical Schematics:		
21B loader		
121B loader: up to Serial Number DAH1218599		
221B loader: up to Serial Number DAH 2218599.....	4001	7-57990GB and 7-57990R1GB
Electrical Schematics:		
121B loader: Serial Number DAH 1218600 and after		
221B loader: Serial Number DAH 2218600 and after.....	4001	7-84110GB
Starter motor.....	4003	7-57800GB
Alternator	4004	7-58010GB
5 STEERING SYSTEM		
Rotary Control Valve	5001	7-58020GB
6 TRANSMISSION COMPONENTS		
Travel Reduction Gear: 21B loader.....	6001	
Rear Axle and Transfer Box	6002	
Front Axle.....	6003	
7 DRIVE TRAIN		
Master cylinder: 21B loader	7001	7-58070GB
Master cylinder: 121B - 221B.....	7001	7-58140GB

 Section to be distributed at a later date

DIVISION/SECTION	SECTION No.	REFERENCE No.
8 UNDERCARRIAGE HYDRAULICS		
Checks, Adjustments and Hydraulic Schematics:		
21B loader		
121B loader: up to Serial Number DAH 1218599		
221B loader: up to Serial Number DAH 2218599	8001	7-58080GB and 7-58080R1GB
Checks, Adjustments and Hydraulic Schematics:		
121B loader: Serial Number DAH 1218600 and after		
221B loader: Serial Number DAH 2218600 and after.....	8001	7-84120GB
Variable Displacement Pump: 21B loader.....	8002	7-58090GB
Variable Displacement Pump: 121B - 221B loaders	8002	7-58100GB
Travel motor:		
21B loader: Up to Serial Number DAH 216074	8003	7-58170GB and 7-58170R1GB
Travel motor:		
21B loader: Serial Number DAH 216075 and after.....	8003	7-58030GB and 7-58030R1GB
Travel motor:		
121B loader: up to Serial Number DAH 1216059		
221B loader: up to Serial Number DAH 2216059.....	8003	7-58180GB and 7-58180R1GB
Travel motor:		
121B loader: up to Serial Number DAH 1216060 and after		
221B loader: up to Serial Number DAH 2216060 and after.....	8003	7-58150GB and 7-58150R1GB
Control Valve: 21B loader.....	8004	7-58110GB
Control Valve: 121B - 221B loaders	8004	7-58130GB
Cylinders	8006	7-58120GB

Section

1001

SAFETY, GENERAL AND STANDARD TORQUE SETTINGS

<https://www.ebooklibonline.com>

Hello dear friend!

Thank you very much for reading.

Enter the link into your browser.

The full manual is available for immediate download.

<https://www.ebooklibonline.com>

SAFETY



*This symbol means **WARNING! TAKE CARE! YOUR SAFETY IS CONCERNED.** The message which follows this symbol contains important safety messages. Read it carefully. Make sure that you have fully understood the causes of possible serious injuries.*

To avoid all accidents, follow the safety notes in this section and other notes that you will find throughout this manual.



PDG0328



Read the operator's manual to familiarize yourself with the controls and their correct use.



The operator must be seated in the operator's seat to operate the machine and the attachments controls. Any other way of proceeding can cause a serious accident.



This is a machine for use by one single person. No passengers are allowed.



Before starting the engine, read the safety messages shown in the operator's manual. Read all decals concerning safety which are mounted on the machine. Make sure that no-one is within the working area. Learn to use the controls in a safe manner before working with them. You must understand and follow the manufacturer's instructions for the operation and maintenance of the machine and respect current laws and regulations. Operator's manuals and service manuals can be ordered from you CASE Dealer.



You risk an accident if you wear clothing which is too loose or if you do not use the safety equipment which is appropriate for your work. Always wear clothing which will not catch on objects. Among extra safety equipment which may be necessary are a helmet, safety shoes, ear, eye and face protection, thick gloves and reflective clothing.



When working near the fan, with the engine running, do not wear loose clothing and be very careful.



*When making inspections or tests on hydraulic equipment, follow the procedures to the letter. **DO NOT** modify the procedures.*



When this machine's hydraulic cylinders are operated to check for correct operation or to bleed air from the circuit, make sure that no person is standing in the working range.



Use heat-protective gloves when handling hot parts.



Lower all the attachments to the ground or use safe supports for the attachments before starting maintenance and repairs.



Splashes or very fine jets of hydraulic oil under pressure can penetrate the skin and cause serious infection. If hydraulic oil under pressure penetrates the skin, medical treatment must be sought immediately. Keep all hoses and pipes in good condition. Ensure that all unions are tightened. Replace any hose or pipe which is defective or likely to become defective. DO NOT use your hands to check for leaks, use a piece of cardboard or wood.



When replacing a heat treated shaft, such as the pivot shaft or any other heat treated shaft, use a copper or bronze headed mallet, or use a piece of copper or bronze between the shaft and the hammer or mallet.



When using a hammer to install pivot shafts, accessories operated by compressed air or when using a grinder, suitable eye protection must be worn, completely covering the eyes (work goggles or any other approved form of protection).



To lift the wheels or tracks off the ground, use jacks, chain lifting devices and make sure that the ground is suitable. Always use suitable, safe supports to support the machine.



When servicing or repairing the machine, there must be no oil, grease, tools etc. on the workshop floor, cab floor or on the steps. If necessary, use a substance to absorb oil and wear workshop clothing. Always use safe methods.



Some components of this machine are very heavy. Use suitable lifting equipment or request help as shown in this manual.



Exhaust gases can cause death. If it is necessary to run an engine in an enclosed space, the exhaust gases must be evacuated from that space by an evacuation pipe. Open the doors and allow air from outside into the area where the engine is running.



When battery electrolyte is frozen, it may explode : (1) if you try to charge it or (2) to start up the engine using a booster source of electrical power. To prevent the electrolyte from freezing, make sure the battery is always fully charged. If these instructions are not observed, there is a risk of injury to persons in the vicinity.



Batteries contain acid and explosive gases. Explosions can be caused by sparks, flames or poorly connected cables. See the Operator's Manual for correct connection of battery cables on this machine. If these instructions are not observed, serious injury can result.

GENERAL

CLEANING

Clean all metal parts except bearings in white spirit or use steam. Do not use caustic soda when steam cleaning. After cleaning dry and oil all parts. Clean oil passages using compressed air. Clean bearings in kerosene. Dry them completely and then lubricate them.

INSPECTION

Check all parts once they have been removed. Replace all parts showing wear or damage. Shallow pitting or scratches can be removed by honing or with a cloth dipped in polishing rouge. A full visual inspection to detect wear and pitting and the replacement of parts as required will prevent premature failures.

BEARINGS

Check that the bearings turn freely. If there is too much float or if they do not operate smoothly, they must be replaced. Clean bearings using a good solvent or kerosene and allow them to dry in the air. **DO NOT DRY BEARINGS WITH COMPRESSED AIR.**

NEEDLE BEARINGS

Before pressing needle bearings into a bore, always remove any metal protrusion from the bore or its surroundings. Before using a press to install bearings, coat the inside and the outside of the bearings with Vaseline.

GEARS

Check all gears for wear and damage. Replace worn or damaged gears.

SEALING RINGS, O-RINGS AND GASKETS

Always install new sealing rings, O-rings and gaskets. Coat sealing rings, O-rings and gaskets with Vaseline.

SHAFTS

Check all shafts showing signs of wear or damage. Check that the surface of the shaft where a bearing or sealing ring is fitted shows no signs of damage.

PARTS

Always install CASE genuine parts. When making out a parts order, consult the Parts Catalogue to be able to give the correct part numbers for the genuine CASE part. Failures due to the use of parts other than genuine CASE parts are not covered by the warranty.

LUBRICATION

Only use oils and lubricants specified in the Operator's Manual or Service Manual. Failures caused by the use of non-specified oils and lubricants are not covered by the warranty.

Section

1002

SPECIFICATIONS

21B Loader

1002

MACHINE OVERALL DIMENSIONS AND WORKING RANGE

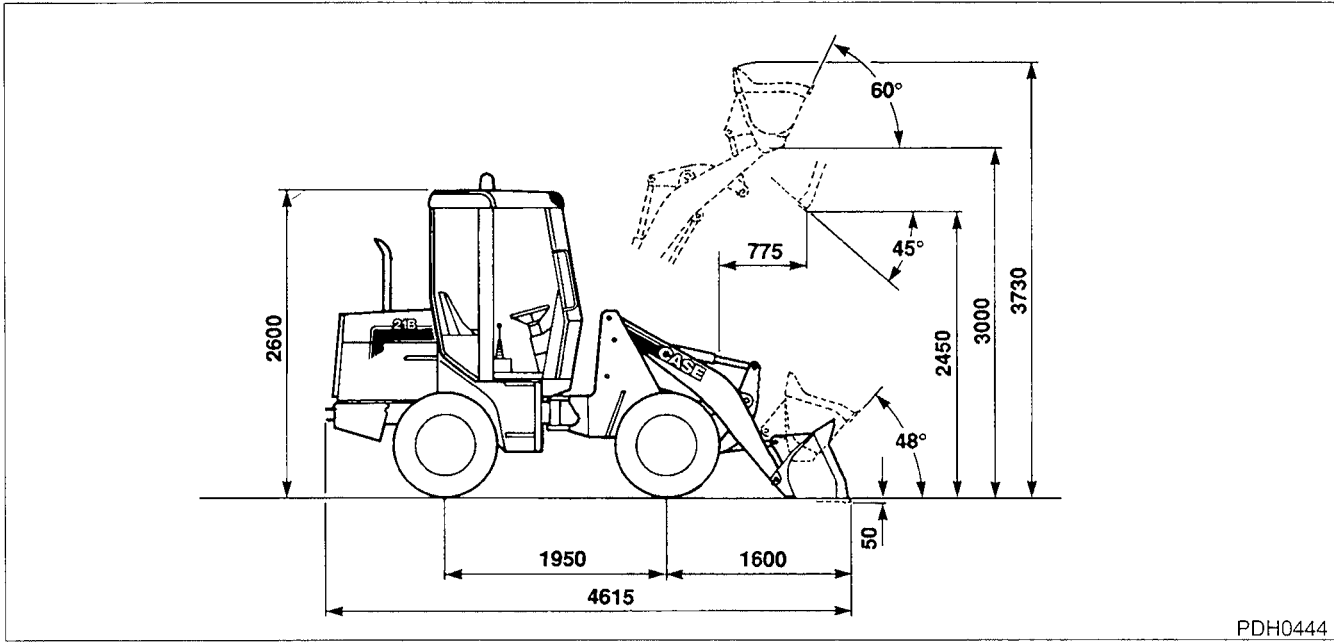

PDH0444

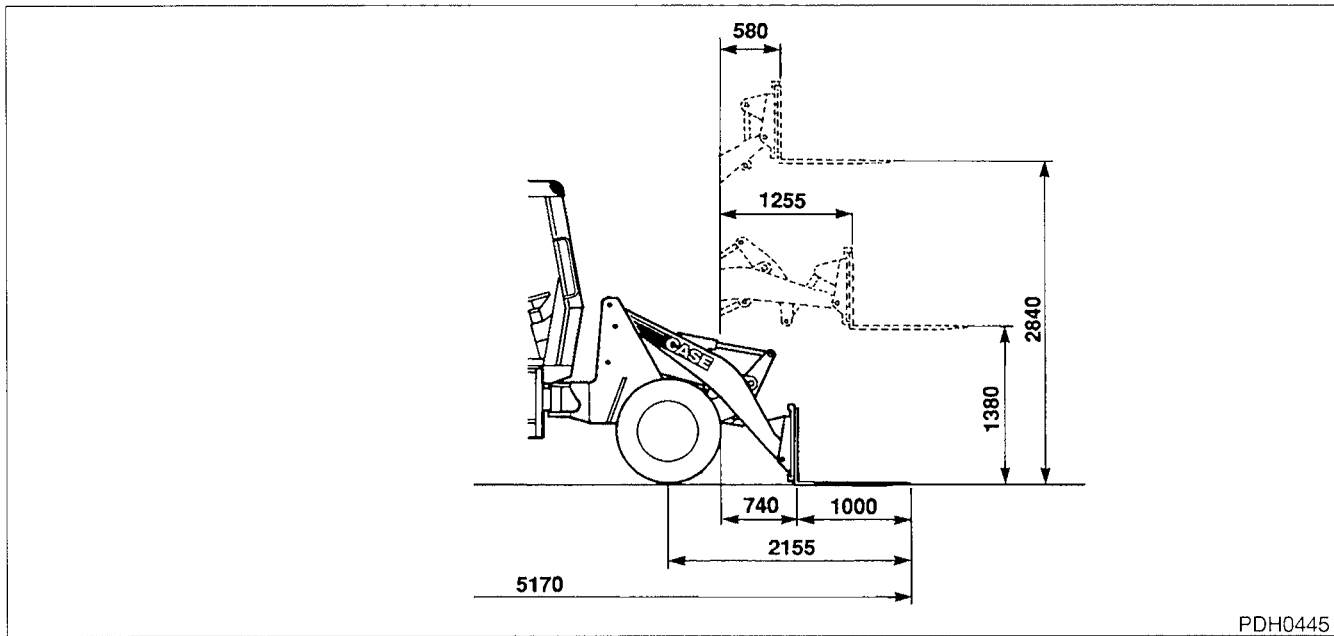

PDH0445

DIESELMOTOR

Make and model	Perkins 504-2
SAE horsepower rating	45 hp (33 kW) at 2500 rpm
DIN 6271 horsepower rating	42 hp (31 kW) at 2500 rpm
EEC 80/1269 horsepower rating	42 hp (31 kW) at 2500 rpm
Maximum torque EEC 80/1269	121 Nm at 2200 rpm
Displacement	2000 cc
Number of cylinders	4
Bore x stroke	84.5 x 88.9 mm
Compression ratio	17 : 1
Injection system	direct
Air filter	dry type
Restriction indicator on instrument panel.	
Oil filter	screw-on element

ELECTRICAL SYSTEM

Voltage	12 volts
Battery	1 x 12 volts
Alternator	45 Amp

TRANSMISSION

Hydrostatic

Closed circuit automatic power regulation.

A single electrically controlled lever selects two forward and reverse speeds plus the direction of travel.

Hydraulic system

Variable displacement piston pump with forced-feed pump, attached to the engine, driven directly by the engine.

Double displacement piston motor.

Interchangeable 10 micron filter on the inlet circuit, with restriction indicator on instrument panel.

Working pressure.....400 bar

Travel speeds

Engine at full speed - 10.5 x 18 tyres

Forward/Reverse direction of travelFirst speed : 9 km/h
 Second speed : 24 km/h
 (special for Germany) : 20 km/h

AXLES

Front axle

Rear axle.....oscillating (+, -) 20°

TYRES

Standard10.5 x 18

BRAKES

Service brake

Hydraulically operated disc brake mounted on the transmission shaft.

Parking brake

Manually operated disc brake mounted on the transmission shaft.

STEERING

Type	Hydraulic
Turning angle	(+/-) 40°
Turning radius:	
Tyre inner 10.5 x 18	1.95 m
Bucket outer	3.80 m
Steering cylinders	double acting
diameter x stroke	65 x 255 mm
Pump	gear type
Flow	28 L/min at 2500 rpm
Steering safety valve pressure setting	140 bar

HYDRAULIC SYSTEM

Double-body gear pump, mounted directly on the end of the transmission pump, with driven directly from the engine.

Flow for loader attachment	50 L/min at 2500 rpm
Flow for steering system	28 L/min at 2500 rpm

Mechanically operated modular type, 3 spool open centre control valves.

Working pressure up to	190 bar
------------------------------	---------

Double acting cylinders with hardened, chromium plated rods.

Arm (quantity 1) (diameter x stroke)	85 x 665 mm
Bucket (quantity 1) (diameter x stroke)	70 x 310 mm

Hydraulic reservoir is common with transmission system.

Filtration of the return circuit using 10 micron interchangeable element filter.

Cycle time (with full bucket)

Raising	4.6 seconds
Lowering (empty bucket)	3.4 seconds
Dumping	1 second
Complete cycle time	9 seconds

CAPACITIES

Fuel tank	50 litres
Hydraulic system	
Total	52 litres
Reservoir	40 litres
Engine with filter	5.5 litres
Axle	
Front	10 litres
Rear	12 litres
Reduction gear	0.5 litres
Brake system	0.2 litres
Cooling system	12 litres

PERFORMANCE AND SPECIFICATIONS

Performance

Standard bucket capacity	0.55 m ³
Breakout force	3510 daN
Tipping load	
In line	2350 kg
Turned 40°	2030 kg
Dimensions and weights	
Track	1.22 m
Ground clearance	0.28 m
Width at tyre outer	1.49 m
Width of bucket	1.60 m
Standard all-up weight	3300 kg
Maximum all-up weight	3650 kg

Specifications

Electrical speed selection

One single lever located near the steering wheel provides electrical selection of speeds and direction of travel.

Smooth controls

One single cross-pattern lever for the loader attachment functions.
The second lever is provided to operate an optional attachment.

Electronic monitoring system

A comprehensive instrument panel is located in front of the operator.
The main functions of the machine are equipped with visual and audible warning devices.

Super comfort cab

Cab, mounted on flexible mountings, to ROPS and FOPS standards, is sound proofed and has large areas of safety glass to give total visibility.
Adjustable suspension seat.
High performance heating and ventilation.

Hydraulically controlled quick hitch

The hydraulically controlled quick hitch is a standard feature. It enables buckets and other tools to be changed in a few seconds.

Quick access

The engine hood lifts open towards the rear and gives total accessibility for inspection and maintenance of the main components.

Section

2415

CYLINDER HEAD AND VALVE TRAIN

DIESEL ENGINE

Series 504-2 and 504-2 T

2415

CAMSHAFT COVER

To remove and to fit

To remove

STEP 1

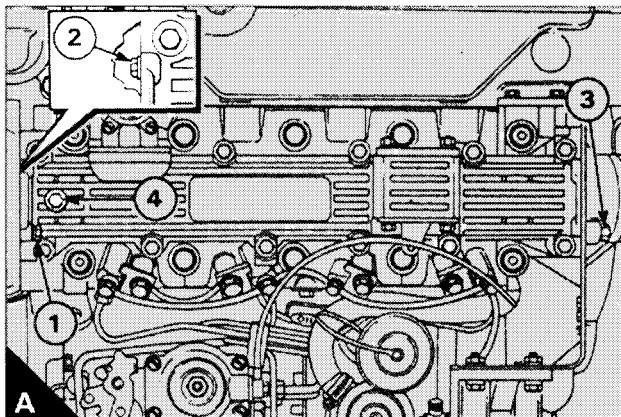

Remove the setscrew which fastens the front flange of the camshaft cover to the timing case (A1).

Some vehicle engines have a setscrew, fitted inside the timing case, which also fastens the timing case to the camshaft cover (A2). For these engines the timing case cover will have to be removed and the setscrew released.

Remove the setscrew from the timing hole in the top front of the camshaft cover (A4). Turn the crankshaft until the timing hole in the front journal of the camshaft aligns with the hole in the cover. This will ensure easier removal of the fuel lift pump and the camshaft cover.

STEP 2

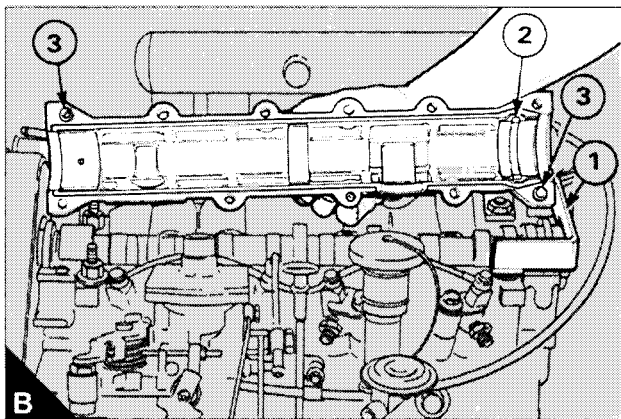

Remove the engine lift brackets, if fitted. If nothing is driven from the rear of the camshaft, remove the rear cover and fit the camshaft retainer PD.181 (B1). This will ensure that the camshaft will not tilt when the camshaft cover is removed.

STEP 3

Remove the fuel lift pump, see Section 3412

STEP 4

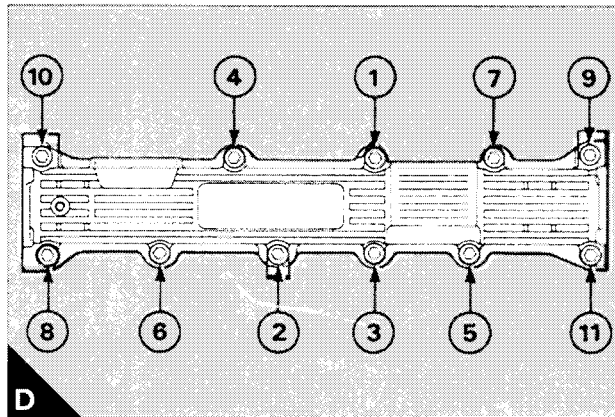

Loosen evenly the setscrews of the camshaft cover in the reverse sequence to that given in figure D. Remove the setscrews and the cover (B). Ensure that the thrust washer (B2) remains in position in the cover.

To fit

STEP 1

Check the cover and the thrust washer for the camshaft for wear and for other damage. If the cover is worn or damaged, a new cylinder head assembly will be needed as the bores for the camshaft journals are machined with the cover and the head fastened together.

STEP 2

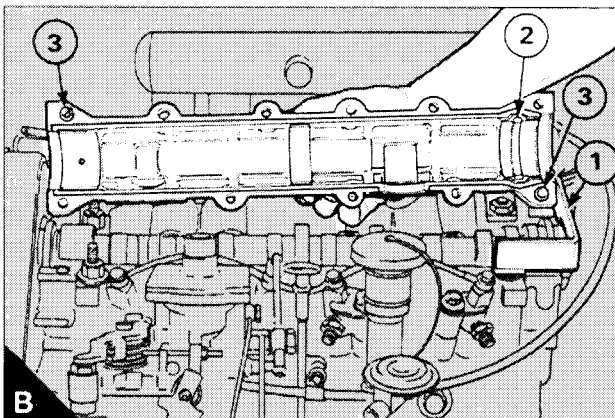

Check that the location thimbles (B3) and the thrust washer (B2) are correctly fitted. Ensure that the front and the rear seals of the camshaft are still in their correct positions against the shoulders in the cylinder head and that they are not tilted.

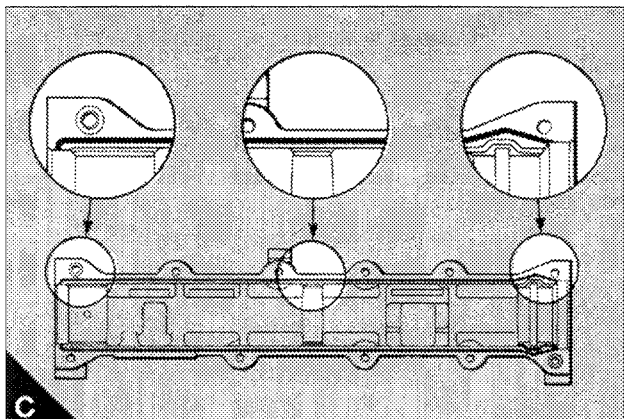
STEP 3

Ensure that the grooves in the camshaft cover and the contact faces of the cylinder head and the cover are clean. Apply a 2 mm (0.08 in) diameter bead of POWERPART Hylosil to the outer grooves of the cover but leave the inner grooves empty, as shown in figure (C). As soon as the sealant has been applied, fit the cover. Fit the cover setscrews with the longer setscrews at each end of the cover. Gradually tighten the setscrews to keep the cover parallel to the cylinder head as it is pulled down. Finally tighten the cover setscrews to 22 Nm (16 lbf ft) 2,2 kgf m in the sequence shown in figure (D).

STEP 4

Where necessary, remove the camshaft retainer and fit the rear end cover.

STEP 5

Fit and tighten the setscrew(s) which fasten(s) the timing case to the camshaft cover. If necessary, fit the timing case cover.

STEP 6

Ensure that the timing hole in the front journal of the camshaft aligns with the timing hole in the camshaft cover. Fit the fuel lift pump, see Section 3412. Fit the setscrew in the timing hole in the camshaft cover. If necessary, fit the engine lift brackets.

TAPPET CLEARANCES**To check****Special tools :**

Camshaft retainer, PD.181

Camshaft, PD.180

Note : *The tappet clearances are measured between the camshaft and the top of the tappets (A). With the engine cold, the correct clearances are 0,25/0,35 mm (0.010/0.014 in) for the inlet valves and 0,35/0,45 mm (0.014/0.018 in) for the exhaust valves. See B for the position of the inlet and exhaust cams.*

Number 1 cam is at the pulley end of the camshaft.

Attention : If the cylinder head is not fitted to the engine, see Step 16, page 23.

STEP 1

Disconnect the battery.

STEP 2

Remove the camshaft cover, see page 7.

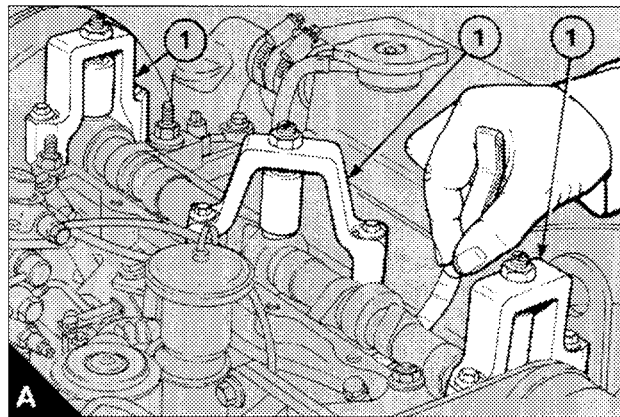
STEP 3

Fit the camshaft clamps PD.180 (A1) to retain the camshaft and fit the relevant cover setscrews to the clamps. It will be necessary to move the rear seal on the camshaft to ensure that there is clearance between the rear clamp and the seal. Ensure that the spring loaded pads are correctly fitted on the camshaft journals and tighten evenly the clamp setscrews.

STEP 4

Turn the crankshaft until the lobes of numbers 1 and 3 cams are both near to their top position. Use feeler gauges with bent blades to measure the tappet clearances of numbers 1 and 3 valves. Make a note of the clearances.

STEP 5

Repeat 4 for valves 2 and 5, 6 and 8, and 4 and 7.

STEP 6

Adjustment is only necessary if the clearances are outside the limits of 0,20/0,40 mm (0.008/0.016 in) for inlet valves or 0,30/0,50 mm (0.012/0.020 in) for exhaust valves. If adjustment is necessary, see page 10.

STEP 7

When the clearances are correct, remove the camshaft journal clamps and fit the camshaft cover, see page 7.

STEP 8

Connect the battery.

To adjust**Special tools :**

Camshaft clamps : PD.180

Camshaft retainer : PD.181

Timing pins for camshaft and crankshaft, PD.182

Location pins for the pulley of the injection pump, PD.190

Anti-rotation tool, PD.203

Note : if it is found during a check of the tappet clearances, that adjustment is necessary, proceed as follows .

Attention : If the cylinder head is not fitted to the engine, see Step 16, page 23.

STEP 1

Turn the crankshaft until the timing hole in the front journal of the camshaft is in the 12 o'clock position. Fit the timing PD.182 through backplate or through the flywheel housing into the timing hole in the flywheel. Remove the starter motor, and fit the anti-rotation tool PD.203 to the flywheel.

STEP 2

Remove the timing case cover, see Section 2425.

STEP 3

Loosen the setscrews of the camshaft pulley and the setscrew of the pulley hub.

STEP 4

Fit the location pins PD.190 to hold the pulley of the fuel injection pump.

STEP 5

Remove the timing belt, the camshaft pulley and the pulley hub, see section 15.

STEP 6

Remove the camshaft retainer.

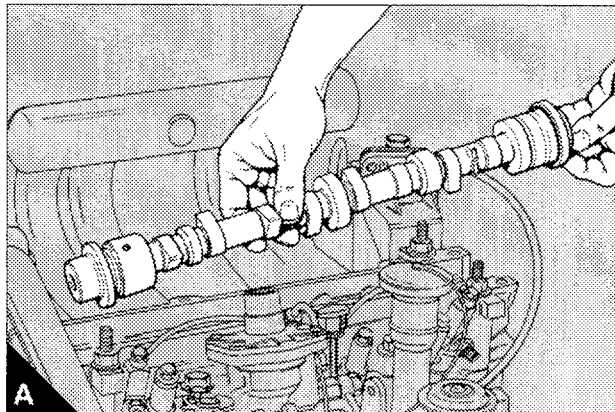
STEP 7

Remove the camshaft clamps and remove the camshaft (A). Remove the seals from the camshaft.

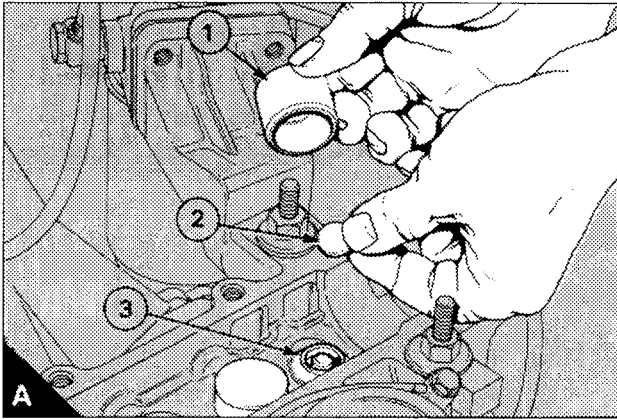
STEP 8

Adjust at each tappet in sequence : Remove the tappet (A1) and remove the shim (A2) which is fitted in the top of the valve spring cap (A3). From the notes obtained to the page 8, find the amount of adjustment needed for this tappet. Measure the thickness of the shim. If the clearance needs to be increased, put in a shim which is thinner by the necessary amount. If the clearance needs to be decreased, put in a thicker shim. For calculation purposes, use the average clearances of 0,30 mm (0.012 in) for inlet valves and 0,40 mm (0.016 in) for exhaust valves. Lubricate the tappet and fit it into its bore. Repeat the operation for each tappet which needs adjustment.

STEP 9

When all the necessary shims have been changed, put the camshaft in position and temporarily fit the hub for the camshaft pulley. Remove the timing pin and the anti-rotation tool from the flywheel. Turn the crankshaft a quarter of a turn in a clockwise direction. Fit the camshaft clamps PD.180 and check that the tappet clearances are correct, see page 8.

STEP 10

When the clearances are correct, remove the hub for the camshaft pulley and the camshaft clamps. Turn the crankshaft a quarter of a turn in a counter-clockwise direction. Fit the timing pin and the anti-rotation tool to the flywheel. Lubricate the tappets and the journals and cams of the camshaft.

STEP 11

Fit the camshaft cover, see page 7.

STEP 12

Fit new front and rear seals to the camshaft, see page 11.

STEP 13

Fit the camshaft pulley and the timing belt, see Section 2425. Remove the location pins from the pulley of the fuel injection pump and adjust the belt tension, see Section 2425.

STEP 14

Remove the flywheel timing pin and the anti-rotation tool. Check the timing of the fuel injection pump, see Section 3412.

STEP 15

Fit the timing case cover, see Section 2425.

STEP 16

Fit the setscrew in the timing hole of the camshaft cover. Fit the rear plate of the camshaft cover.

STEP 17

Turn the crankshaft through two revolutions to ensure that there is no restriction to movement.

STEP 18

Fit the starter motor, and connect the battery.

FRONT OIL SEAL OF CAMSHAFT

To remove and to fit

Special tools :

Remover for front seal of camshaft, PD.185

Replacer for front seal of camshaft, PD.186

Timing pins for camshaft and crankshaft, PD.182

Location pins for the pulley of the fuel injection pump, PD.190

Anti-rotation tool, PD.203

STEP 1

Disconnect the battery.

STEP 2

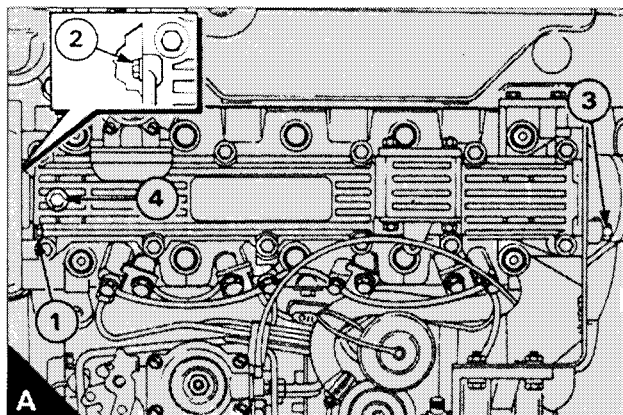

Remove the setscrew from the timing hole in the top front of the camshaft cover (A4). Turn the crankshaft until the timing hole in the front journal of the camshaft aligns with the hole in the cover.

STEP 3

Fit the timing pins PD.182 to the camshaft and to the flywheel. Remove the starter motor, and fit the anti-rotation tool PD.203 to the flywheel.

STEP 4

Remove the timing case cover, see Section 2425.

STEP 5

Remove the camshaft pulley, see Section 2425.

STEP 6

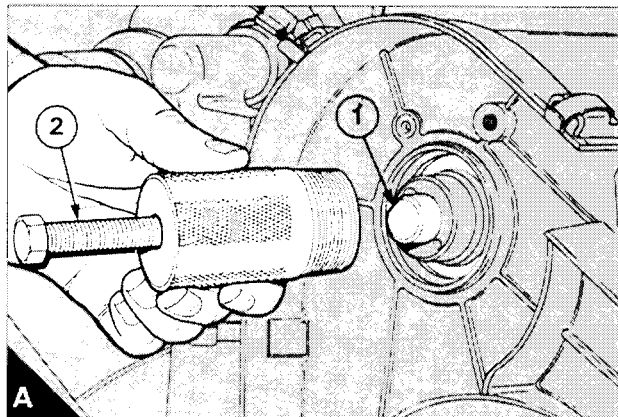

Fit the plug of tool PD.185 (A1) into the front end of the camshaft. Release the centre screw (A2) enough to ensure that it will not reach the plug and enter the main tool into the seal. Turn the tool clockwise to ensure that it is tight in the seal and tighten the centre screw onto the plug to remove the seal.

STEP 7

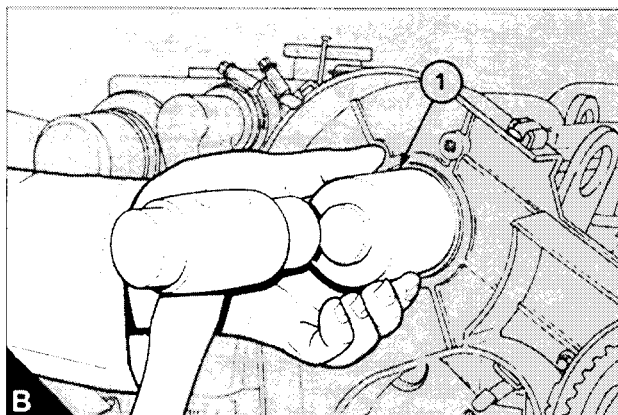

Ensure that the seal housing and the camshaft are clean and that they are not damaged. Lubricate the new seal with clean engine lubricating oil and enter it into position with the seal lip to the inside. Use the seal replacer PD.186 (B1) with a soft face hammer to fit the seal into its final position.

STEP 8

Fit the camshaft pulley and the timing belt, see Section 2425. Remove the location pins from the pulley of the fuel injection pump and adjust the tension of the timing belt, see Section 2425.

2415-12

STEP 9

Remove the anti-rotation tool.

STEP 10

Check the timing of the fuel injection pump, see Section 3412.

STEP 11

Remove the timing pins and turn the crankshaft through two revolutions to ensure that there is no restriction to movement.

STEP 12

Fit the setscrew in the timing hole in the camshaft cover. Fit the starter motor, and connect the battery.

REAR OIL SEAL OF CAMSHAFTS

To remove and to fit

Special tools :

Remove for rear seal of camshaft, PD.187

Replacer for rear seal of camshaft, PD.188

STEP 1

Remove the rear cover of the camshaft.

STEP 2

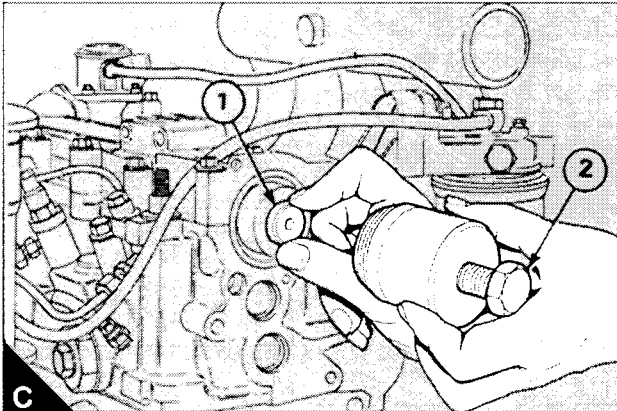

Fit the plug of tool PD.187 (C1) into the rear of the camshaft. Release the centre screw (C2) enough to ensure that it will not reach the plug and enter the main tool into the seal. Turn the tool clockwise to ensure that it is tight in the seal and tighten the centre screw onto the plug to remove the seal.

STEP 3

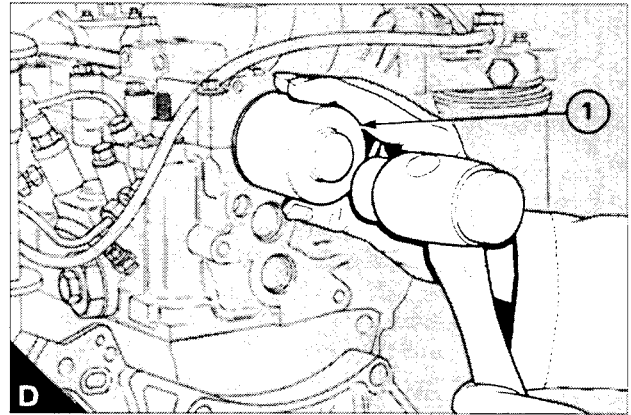

Ensure that the seal housing and the camshaft are clean and that they are not damaged. Lubricate the new seal with clean engine lubricating oil and enter it into position with the seal lip to the inside. Use the seal replacer PD.188 (D1) with a soft face hammer to fit the seal into its final position.

STEP 4

Fit the rear cover of the camshaft.

CAMSHAFT

To remove and to fit

STEP 1

Disconnect the battery.

STEP 2

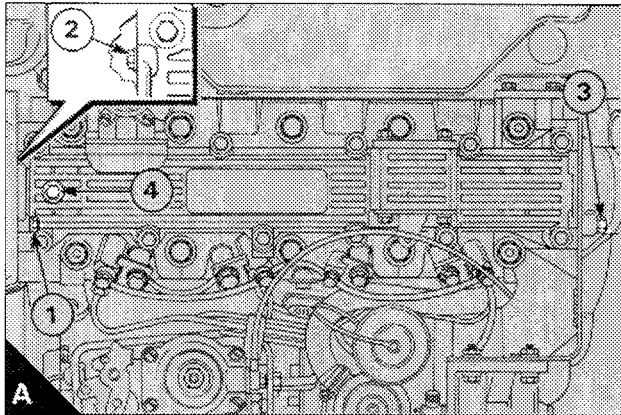

Remove the setscrew from the timing hole in the top front of the camshaft cover (A4). Turn the crankshaft until the timing hole in the front journal of the camshaft aligns with the hole in the cover.

STEP 3

Fit the timing pins PD.182 to the camshaft and to the flywheel. Remove the starter motor, and fit the anti-rotation tool PD.203 to the flywheel.

STEP 4

Remove the timing case cover, see Section 2425.

STEP 5

Remove the camshaft pulley, see Section 2425.

STEP 6

Remove the camshaft cover, see page 7.

STEP 7

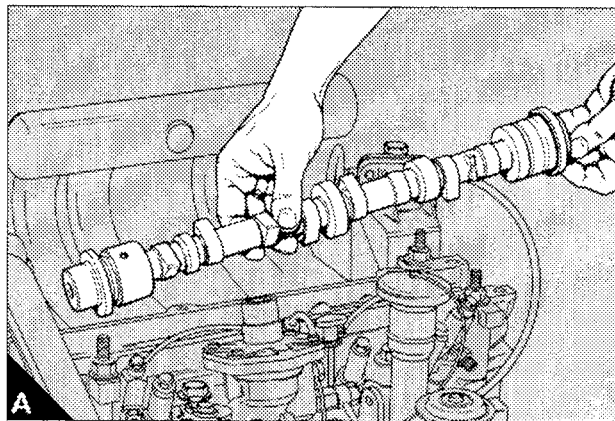

Remove the camshaft (A) and remove the camshaft seals. Check the camshaft for wear and for damage and renew it, if necessary.

STEP 8

Ensure that the camshaft is clean and lubricated with clean engine oil. Put the camshaft in position and, if necessary, check the tappet clearances, see page 8.

STEP 9

Fit the camshaft cover, see page 7.

STEP 10

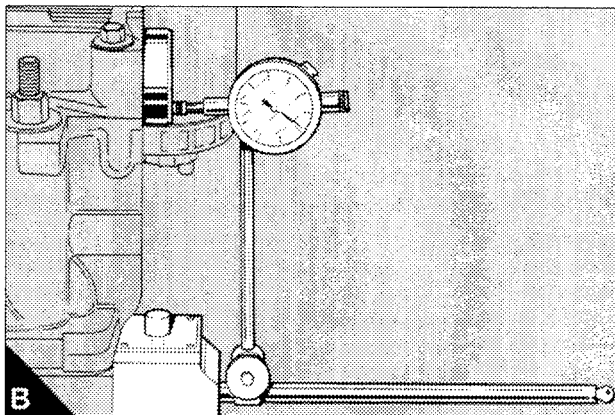

Check the end-float of the camshaft with a dial test indicator (B)

STEP 11

Fit the camshaft seals, see page 11.

STEP 12

Fit the rear cover of the camshaft.

2415-14

STEP 13

Fit the camshaft pulley and the timing belt and adjust the belt tension, Section 2425.

STEP 14

Check the timing of the fuel injection pump, see Section 3412.

STEP 15

Fit the timing case cover, see Section 2425. Fit the setscrew in the timing hole in the top front of the camshaft cover. **Ensure that all the timing pins and the anti-rotation tool are removed.** Turn the crankshaft through two revolutions to ensure that there is no restriction to movement;

STEP 16

Fit the starter motor and connect the battery.

CYLINDER HEAD ASSEMBLY

To remove and to fit

To remove

STEP 1

Disconnect the battery.

STEP 2

Drain the cooling system.

STEP 3

Disconnect the coolant hose from the thermostat housing. If necessary, disconnect the by-pass hose at the bottom of the thermostat housing. If necessary, disconnect the heater hoses.

STEP 4

Disconnect all electrical connections at the cylinder head and the thermostat housing.

STEP 5

Disconnect the air inlet pipe and the exhaust pipe.

STEP 6

If the cylinder head is to be dismantled, remove the inlet and the exhaust manifolds.

STEP 7

Disconnect the fuel lift pump.

STEP 8

Disconnect the fuel filter and remove it from its bracket.

STEP 9

Remove the high-pressure pipes from the atomisers and from the fuel injection pump - do not bend the pipes. When a pipe nut is loosened at the pump, hold the outlet connection of the pump with a spanner to prevent movement of the connection. Fit covers to the open connections of the atomisers and of the pump.

STEP 10

Remove the atomisers, see Section 3412, and the glow plugs, see page 23, to prevent possible damage to their tips.

STEP 11

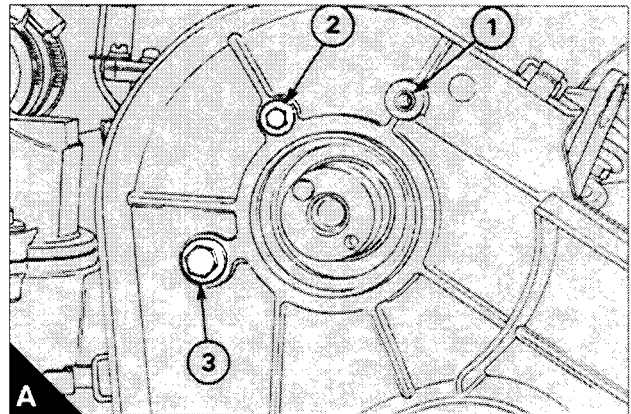

Remove the setscrew from the timing hole in the top front of the camshaft cover (A4). Turn the crankshaft until the timing hole in the front journal of the camshaft aligns with the hole in the cover.

STEP 12

Remove the starter motor, and fit the anti-rotation tool PD.203 to the flywheel.

STEP 13

Remove the timing case cover, see Section 2425, and remove the camshaft pulley, see Section 2425.

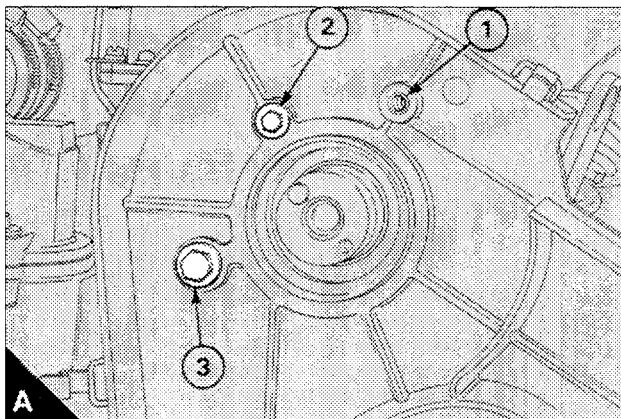
STEP 14

Remove the setscrew which is fitted through the camshaft cover into the timing case (A1). Later engines : Remove the setscrew which fastens the timing case to the cylinder head (A3).

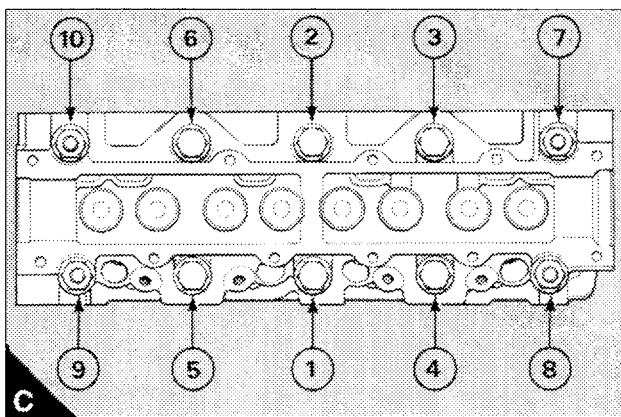
STEP 15

Release evenly the setscrews of the cylinder head in the reverse sequence to that shown in figure (C).

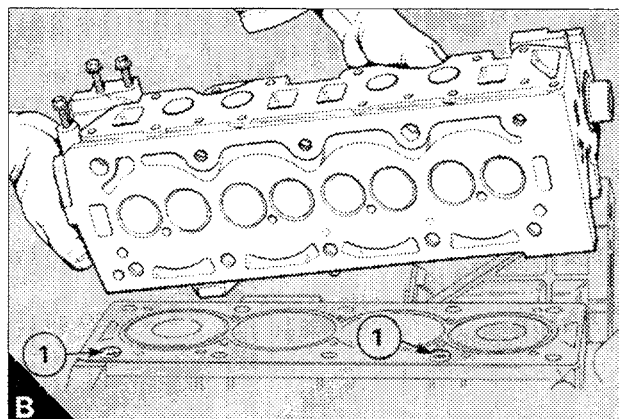
STEP 16

Remove the setscrews and remove the head (B) - ensure that the camshaft does not hit the timing case. Put the head on a flat surface which will not damage the bottom face. Check the top face of each cylinder head setscrew for centre punch marks. If there are four centre punch marks on the setscrew head, it has been tightened four times in service and it cannot be used again. Also check the setscrews for distortion with a straight edge held along the setscrew. If there is a visual reduction in the diameter of the stem or of the thread that has not been in engagement with the cylinder head, the setscrew must be discarded.

STEP 17

Remove the cylinder head gasket.

To fit**Special tools :**

Angle gauge, to tighten cylinder head setscrews, CAS.2162

STEP 1

Clean the bottom face of the cylinder head and the top face of the cylinder block. Ensure that there is no debris in the cylinder bores.

STEP 2

Ensure that numbers 1 and 4 pistons are at TDC and that the timing pin is fitted through the backplate or through the flywheel housing into the timing hole in the flywheel.



Suggest:

If the above button click is invalid.

Please download this document

first, and then click the above link

to download the complete manual.

Thank you so much for reading

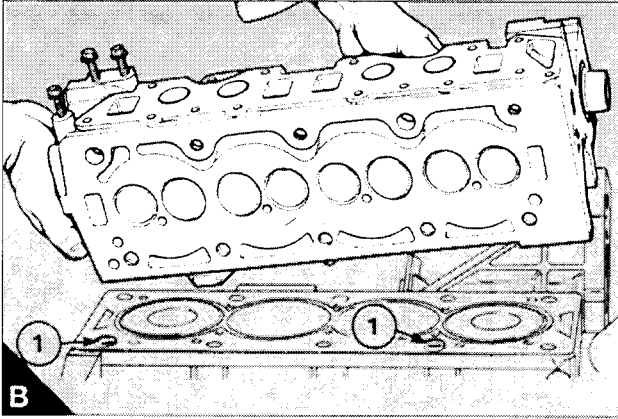
STEP 3

Ensure that the two location thimbles (B1) are in position in the top face of the cylinder block and fit the cylinder head gasket without jointing compound. The gasket will only fit in one position over the thimbles.

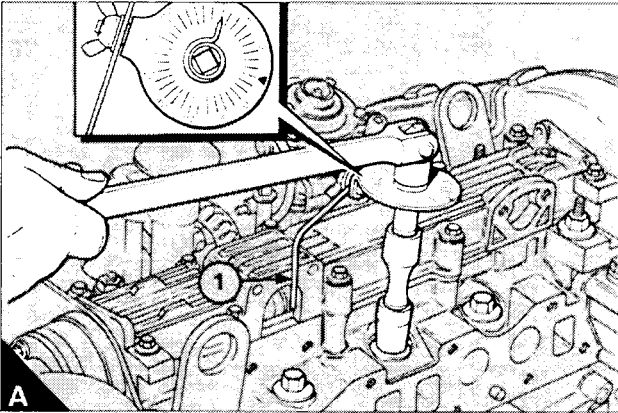
STEP 4

Ensure that the timing pin is fitted through the camshaft cover into the timing hole in the camshaft. Put the cylinder head in position over the thimbles. Engage the cylinder head setscrews with the longer setscrews fitted at the ends of the head. Tighten evenly all the setscrews in the sequence shown in figure (A) to a torque of 50 Nm (37 lbf ft) 5,1 kgf m. Tighten all the setscrews again, in the same sequence, to a torque of 100 Nm (74 lbf ft) 10,2 kgf m. Finally tighten the setscrews, in the same sequence, another quarter of a turn (90°). Tool CAS.2162 can be used for this operation (A). Fit the tool between the socket and the handle. Put the stop (B1) against a suitable protrusion on the cylinder head to prevent movement of the degree dial in a clockwise direction. Turn the pointer to align with the 90° mark on the degree dial. Tighten the setscrew until the pointer aligns with the zero position.

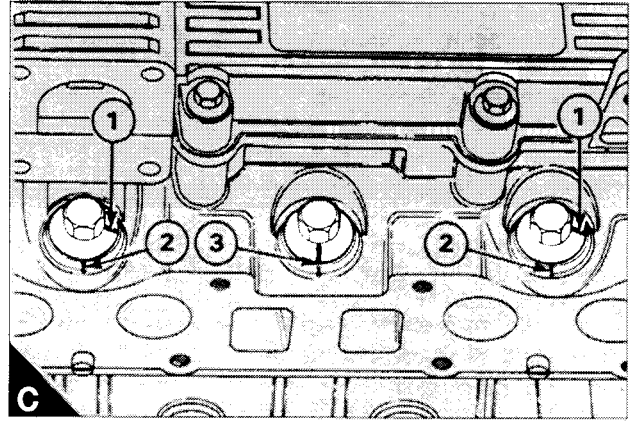

If no tool is available, make a suitable mark on the flange of each setscrew (C1). Make other marks on the cylinder head (C2) at 90° clockwise to the marks on the setscrews. Tighten each setscrew in the correct sequence until the marks on the flange are next to, and line with, the marks on the cylinder head (C3). The setscrews do not need to be tightened again with the engine hot or after a period in service. If the original setscrews have been fitted again, mark the top of each setscrews with a centre punch to indicate that it has been tightened in service. A maximum of four centre punch marks is permissible.

STEP 5

If necessary, fit the inlet and the exhaust manifolds, Section 2425.

STEP 6

Connect the air filter and the exhaust pipe.

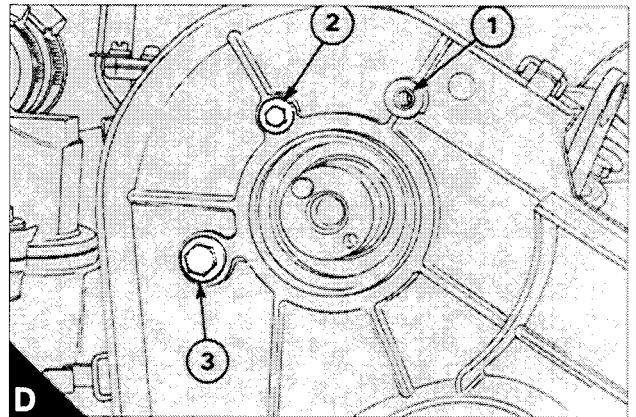
STEP 7

Fit the setscrews which fasten the timing case to the cylinder head (D1) and to the camshaft cover (D1), to the page 7.

<https://www.ebooklibonline.com>

Hello dear friend!

Thank you very much for reading.

Enter the link into your browser.

The full manual is available for immediate download.

<https://www.ebooklibonline.com>