

# WSM

---

## WORKSHOP MANUAL **DIESEL ENGINE**

**03-M-DI-E4B SERIES,  
03-M-E4BG SERIES**

---

**Kubota**

# TO THE READER

This Workshop Manual tells the servicing personnel about the mechanism, servicing and maintenance of the 03-M-DI-E4B and 03-M-E4BG series. It contains 4 parts: "**Information**", "**General**", "**Mechanism**" and "**Servicing**".

## ■ **Information**

This section contains information below.

- Safety First
- Specification
- Performance Curve
- Dimensions
- Wiring Diagram

## ■ **General**

This section contains information below.

- Engine Identification
- General Precautions
- Maintenance Check List
- Check and Maintenance
- Special Tools

## ■ **Mechanism**

This section contains information on the structure and the function of the unit. Before you continue with the subsequent sections, make sure that you read this section.

Refer to Workshop Manual (Code No. 9Y021-01870) for the diesel engine mechanism that this workshop manual does not include.

## ■ **Servicing**

This section contains information below.

- Troubleshooting
- Servicing Specifications
- Tightening Torques
- Checking, Disassembling and Servicing

All illustrations, photographs and specifications contained in this manual are of the newest information available at the time of publication.

KUBOTA reserves the right to change all information at any time without notice.

Since this manual includes many models, information or illustrations and photographs can show more than one model.

## **Record of Revisions**

For pdf, use search function {Search word} to find all the revised locations.

<b>Last digit of the Code No.</b>	<b>Issue month</b>	<b>Main Revised Point and Corrective Measures {Search word}</b>	<b>Reference Page</b>
<b>1</b>	2014.05	2. SPECIFICATION [1] MODEL NAME AND ENGINE SERIAL NUMBER and others	I-4 G-1 and others
<b>2</b>	2017.07	Typo correction • Crank Pulley → Fan Drive Pulley • Oil sensor → Oil switch • Correction of instruction number	G-36 1-S7 1-S44, 1-S59

**<https://www.ebooklibonline.com>**

Hello dear friend!

Thank you very much for reading.

Enter the link into your browser.

The full manual is available for immediate download.

**<https://www.ebooklibonline.com>**

# **I INFORMATION**

# INFORMATION

## CONTENTS

1. SAFETY FIRST .....	I-1
2. SPECIFICATION .....	I-4
3. PERFORMANCE CURVE .....	I-6
4. DIMENSIONS .....	I-7
5. WIRING DIAGRAM.....	I-9

# 1. SAFETY FIRST

## SAFETY FIRST

- This symbol, the industry's "Safety Alert Symbol", is used throughout this manual and on labels on the machine itself to warn of the possibility of personal injury. Read these instructions carefully.
- It is essential that you read the instructions and safety regulations before you attempt to repair or use this unit.

### DANGER

- Indicates an imminently hazardous situation which, if not avoided, will result in death or serious injury.

### WARNING

- Indicates a potentially hazardous situation which, if not avoided, could result in death or serious injury.

### CAUTION

- Indicates a potentially hazardous situation which, if not avoided, may result in minor or moderate injury.

### ■ IMPORTANT

- Indicates that equipment or property damage could result if instructions are not followed.

### ■ NOTE

- Gives helpful information.

M0000003INI0001US1

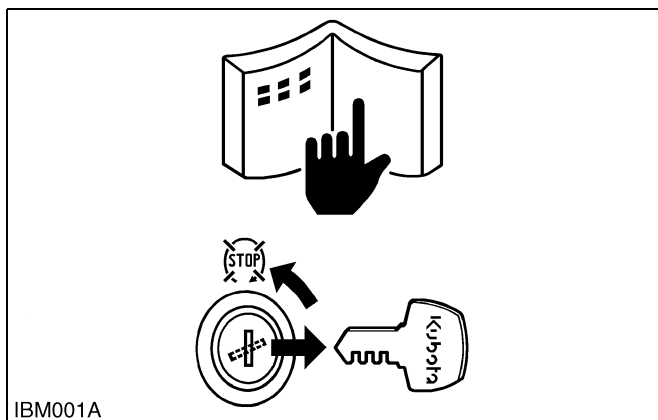

IBM001A

### BEFORE YOU START SERVICE

- Read all instructions and safety instructions in this manual and on your engine safety decals.
- Clean the work area and engine.
- Park the machine on a stable and level ground.
- Let the temperature of the engine decrease before you start a job.
- Stop the engine, then remove the key.
- Disconnect the battery negative cable.
- Hang a "**DO NOT OPERATE**" tag in the operator station.

M0000003INI0002US1



IBM011A

### START SAFELY

- Do not do the procedures below when you start the engine.
  - short across starter terminals
  - bypass the safety start switch
- Do not make unauthorized modifications to the engine. This can cause damage and decrease the engine life.

M0000003INI0003US1

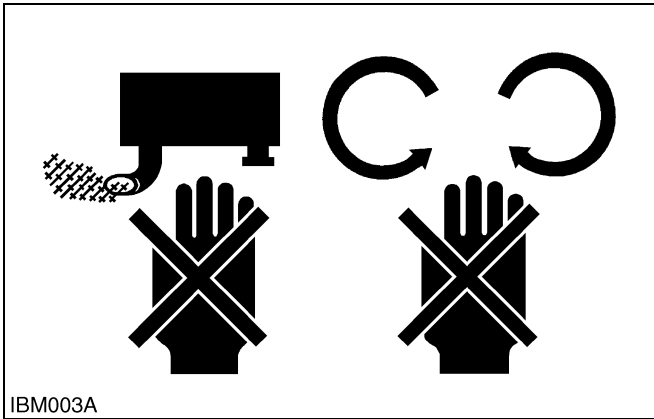

IBM003A

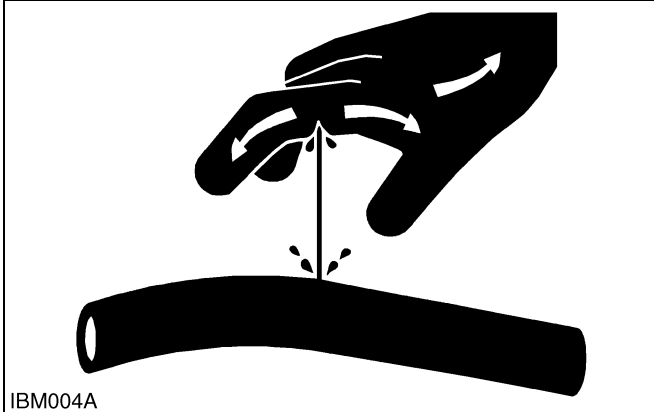

IBM004A

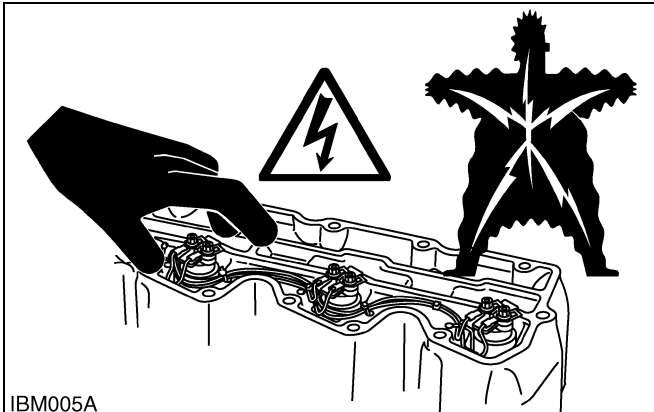

IBM005A

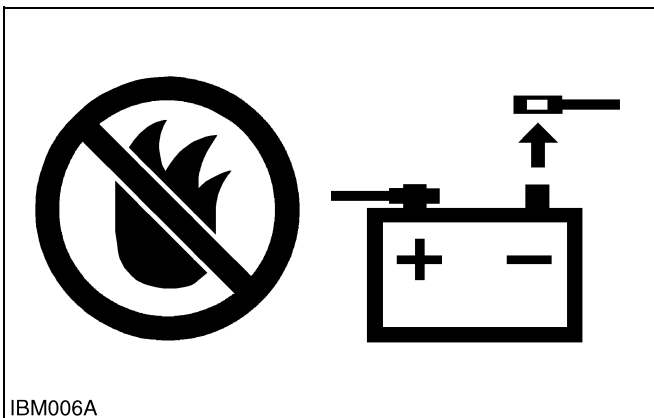

IBM006A

## OPERATE SAFELY

- Do not use the machine after you consume alcohol or medication or when you are tired.
- Put on applicable clothing and safety equipment.
- Use applicable tools only. Do not use alternative tools or parts.
- When 2 or more persons do servicing, make sure that you do it safely.
- Do not touch the hot parts or parts that turn when the engine operates.
- Do not remove the radiator cap when the engine operates, or immediately after it stops. If not, hot water can spout out from the radiator. Only remove the radiator cap when it is at a sufficiently low temperature to touch with bare hands. Slowly loosen the cap to release the pressure before you remove it fully.
- Released fluid (fuel or hydraulic oil) under pressure can cause damage to the skin and cause serious injury. Release the pressure before you disconnect hydraulic or fuel lines. Tighten all connections before you apply the pressure.
- Do not open a fuel system under high pressure. The fluid under high pressure that stays in fuel lines can cause serious injury. Do not disconnect or repair the fuel lines, sensors, or any other components between the fuel pump and injectors on engines with a common rail fuel system under high pressure.
- Put on an applicable ear protective device (earmuffs or earplugs) to prevent injury against loud noises.
- Be careful about electric shock. The engine generates a high voltage of more than DC100 V in the ECU and is applied to the injector.

M0000003INI0004US1

## PREVENT A FIRE

- Fuel is very flammable and explosive under some conditions. Do not smoke or let flames or sparks in your work area.
- To prevent sparks from an accidental short circuit, always disconnect the battery negative cable first and connect it last.
- The battery gas can cause an explosion. Keep the sparks and open flame away from the top of battery, especially when you charge the battery.
- Make sure that you do not spill fuel on the engine.

M0000003INI0005US1

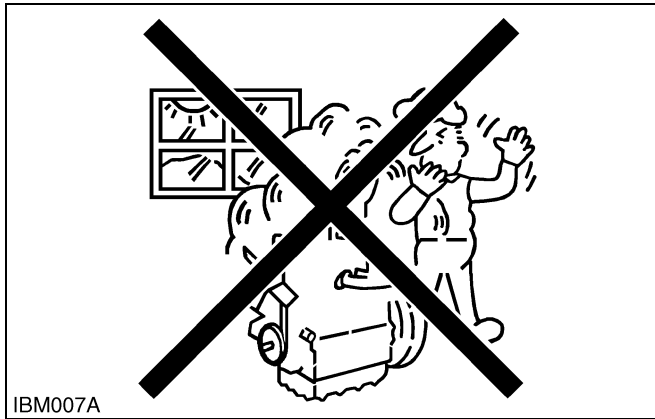

IBM007A

**KEEP A GOOD AIRFLOW IN THE WORK AREA**

- If the engine is in operation, make sure that the area has good airflow. Do not operate the engine in a closed area. The exhaust gas contains poisonous carbon monoxide.

M00000003INI0006US1



IBM009A

**DISCARD FLUIDS CORRECTLY**

- Do not discard fluids on the ground, down the drain, into a stream, pond, or lake. Obey related environmental protection regulations when you discard oil, fuel, coolant, electrolyte and other dangerous waste.

M00000003INI0007US1

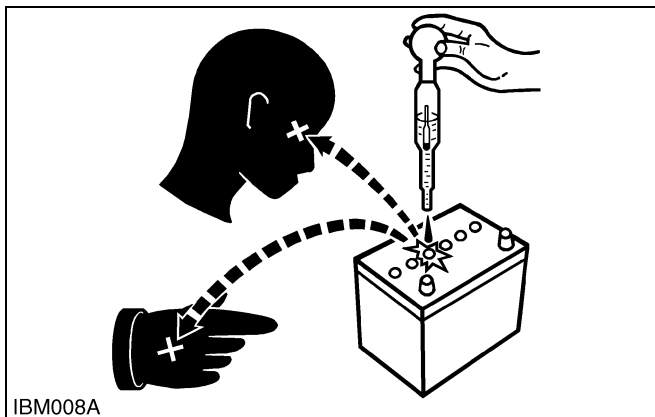

IBM008A

**PREVENT ACID BURNS**

- Keep electrolyte away from your eyes, hands and clothing. Sulfuric acid in battery electrolyte is poisonous and it can burn your skin and clothing and cause blindness. If you spill electrolyte on yourself, clean yourself with water, and get medical aid immediately.

M00000003INI0008US1

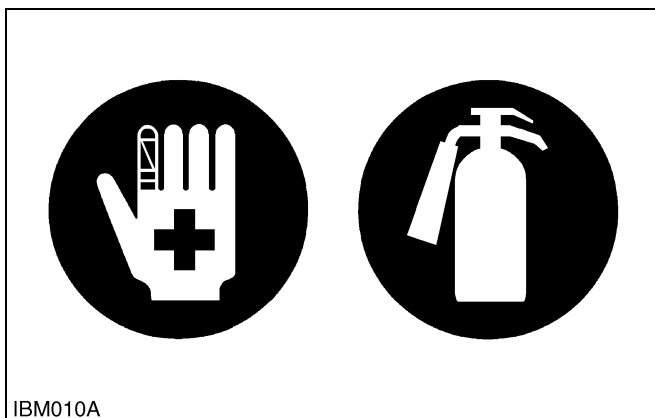

IBM010A

**PREPARE FOR EMERGENCIES**

- Keep a first aid kit and fire extinguisher ready at all times.
- Keep the emergency contact telephone numbers near your telephone at all times.

M00000003INI0009US1

## 2. SPECIFICATION

Model		D1703-M-DI-E4B
Number of Cylinders		3
Type		Vertical, Water-cooled, 4 cycle diesel engine
Bore × Stroke		87.0 × 92.4 mm (3.43 × 3.64 in.)
Total Displacement		1647 cm <sup>3</sup> (100.5 cu.in.)
ISO Net Continuous		15.5 kW / 2200 min <sup>-1</sup> (rpm) (20.8 HP / 2200 min <sup>-1</sup> (rpm))
ISO/SAE Net Intermittent		17.8 kW / 2200 min <sup>-1</sup> (rpm) (23.9 HP / 2200 min <sup>-1</sup> (rpm))
SAE Gross Intermittent		18.5 kW / 2200 min <sup>-1</sup> (rpm) (24.8 HP / 2200 min <sup>-1</sup> (rpm))
Maximum Bare Speed		2450 to 2470 min <sup>-1</sup> (rpm)
Minimum Bare Idling Speed		1050 to 1150 min <sup>-1</sup> (rpm)
Combustion Chamber		Reentrant Type (Direct Injection)
Fuel Injection Pump		Bosch "K" Type Mini Pump
Governor		Centrifugal Ball Type, All Speed Mechanical Governor
Direction of Rotation		Counter-Clockwise (viewed from flywheel side)
Injection Nozzle		Bosch "P" Type Hole Nozzle
Injection Timing		0.0568 to 0.0829 rad (3.25 ° to 4.75 °) Before T.D.C.
Firing Order		1-2-3
Injection Pressure	1st Stage	18.6 MPa (190 kgf/cm <sup>2</sup> , 2700 psi)
	2nd Stage	22.6 MPa (230 kgf/cm <sup>2</sup> , 3270 psi)
Compression Ratio		20.5
Lubricating System		Forced Lubrication by Trochoid Pump
Cooling System		Pressurized radiator, forced circulation with water pump
Starting System		Electric Starting with Starter
Starting Motor		12 V, 1.2 kW
Starting Support Device		Pre-heating by Glow Plug in Combustion Chamber
EGR		NONE
Battery		12 V, 60 AH (75D26R)
Charging Alternator		12 V, 360 W
Fuel		Diesel Fuel No.2-D (or No.2-DLS)
Lubricating Oil		Class CF lubricating oil as per API classification is recommended. For details on recommended lubricating oils, see page G-7, G-10.
Lubricating Oil Capacity	Oil Pan Depth 90 mm (3.5 in.)	5.6 L (1.5 U.S.gals)
	Oil Pan Depth 124 mm (4.88 in.)	7.0 L (1.8 U.S.gals)
Weight (Dry)		148 kg (326 lbs)

\*The specification described above is of the standard engine of each model.

\*Conversion Formula: HP = 0.746 kW, PS = 0.7355 kW

9Y1210967INI0001US0

Model		D1503-M-E4BG
Number of Cylinders		3
Type		Vertical, Water-cooled, 4 cycle diesel engine
Bore × Stroke		83.0 × 92.4 mm (3.27 × 3.64 in.)
Total Displacement		1499 cm <sup>3</sup> (91.47 cu.in.)
STANDBY	ISO 3046	15.5 kW / 1800 min <sup>-1</sup> (rpm)
	SAE J-1349	20.8 HP / 1800 min <sup>-1</sup> (rpm)
NET Continuous	ISO 3046	13.7 kW / 1800 min <sup>-1</sup> (rpm)
	SAE J-1349	18.4 HP / 1800 min <sup>-1</sup> (rpm)
Governor Regulation		Less than 5 %
Combustion Chamber		Spherical Type (E-TVCS)
Fuel Injection Pump		PFR 3M Type Mini Pump (DENSO)
Governor		Centrifugal Ball Type, All Speed Mechanical Governor + Electronic Governor
Direction of Rotation		Counter-Clockwise (viewed from flywheel side)
Injection Nozzle		OPD Mini Nozzle (DENSO)
Injection Timing		0.236 to 0.261 rad (13.5 ° to 15.0 °) Before T.D.C.
Firing Order		1-2-3
Injection Pressure		13.7 MPa (140 kgf/cm <sup>2</sup> , 1990 psi)
Compression Ratio		22.8
Lubricating System		Forced Lubrication by Trochoid Pump
Cooling System		Pressurized radiator, forced circulation with water pump
Starting System		Electric Starting with Starter
Starting Motor		12 V, 1.4 kW
Starting Support Device		By glow plug in combustion chamber
EGR		NONE
Battery		12 V, 60 AH (75D31R)
Charging Alternator		12 V, 480 W
Fuel		Diesel Fuel No.2-D (or No.2-DLS)
Lubricating Oil		Class CF lubricating oil as per API classification is recommended. For details on recommended lubricating oils, see page G-7, G-10.
Lubricating Oil Capacity	Oil Pan Depth 90 mm (3.5 in.)	5.6 L (1.5 U.S.gals)
	Oil Pan Depth 124 mm (4.88 in.)	7.0 L (1.8 U.S.gals)
Weight (Dry)		178 kg (392 lbs)

\*The specification described above is of the standard engine of each model.

\*Conversion Formula: HP = 0.746 kW, PS = 0.7355 kW

9Y1210967INI0002US0

# 3. PERFORMANCE CURVE

D1703-M-DI-E4B

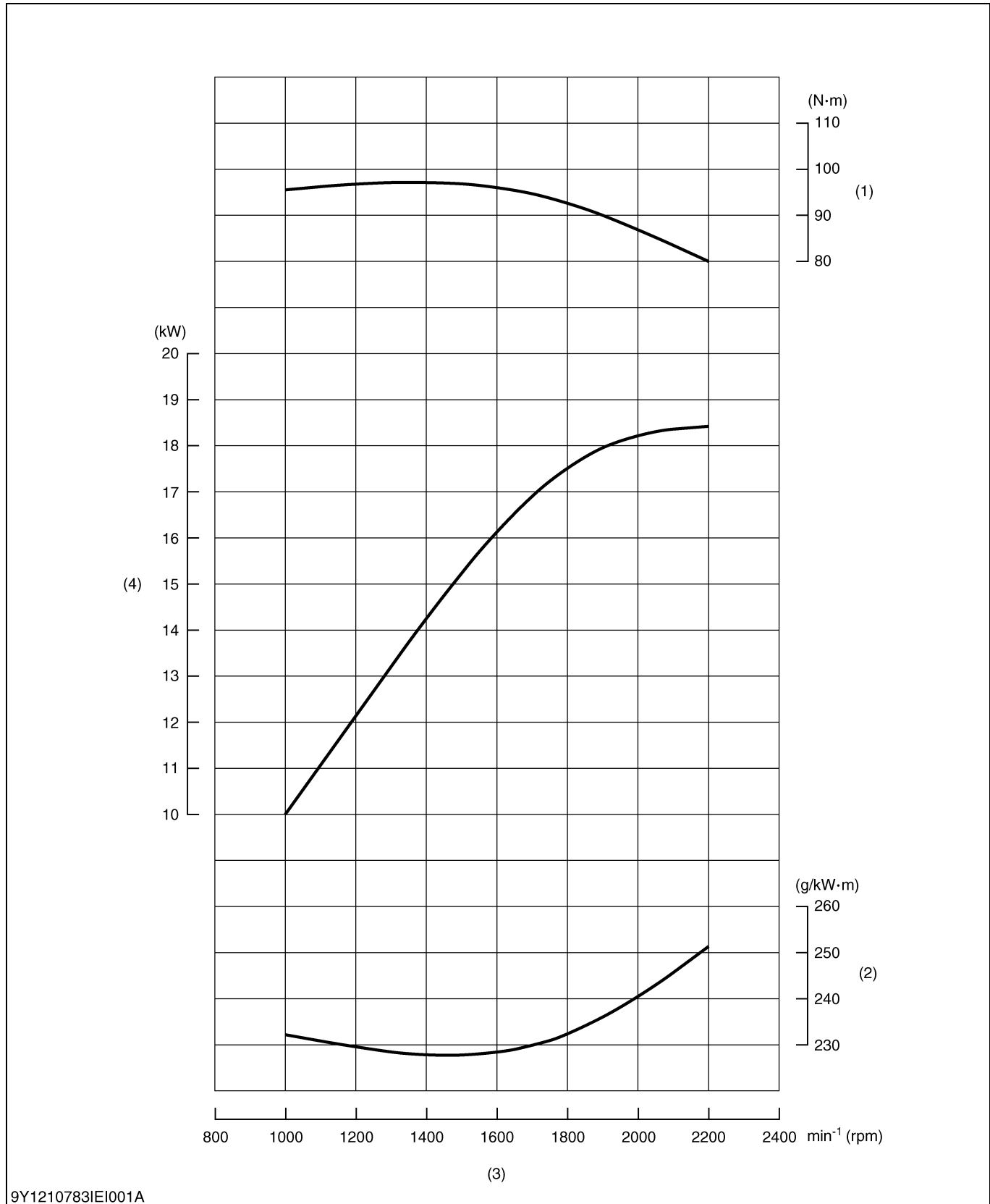

9Y1210783IEI001A

(1) Torque

(2) B.S.F.C. (Brake Specific Fuel Consumption)

(3) Engine Speed

(4) Brake Horsepower

9Y1210967INI0006US0

# 4. DIMENSIONS

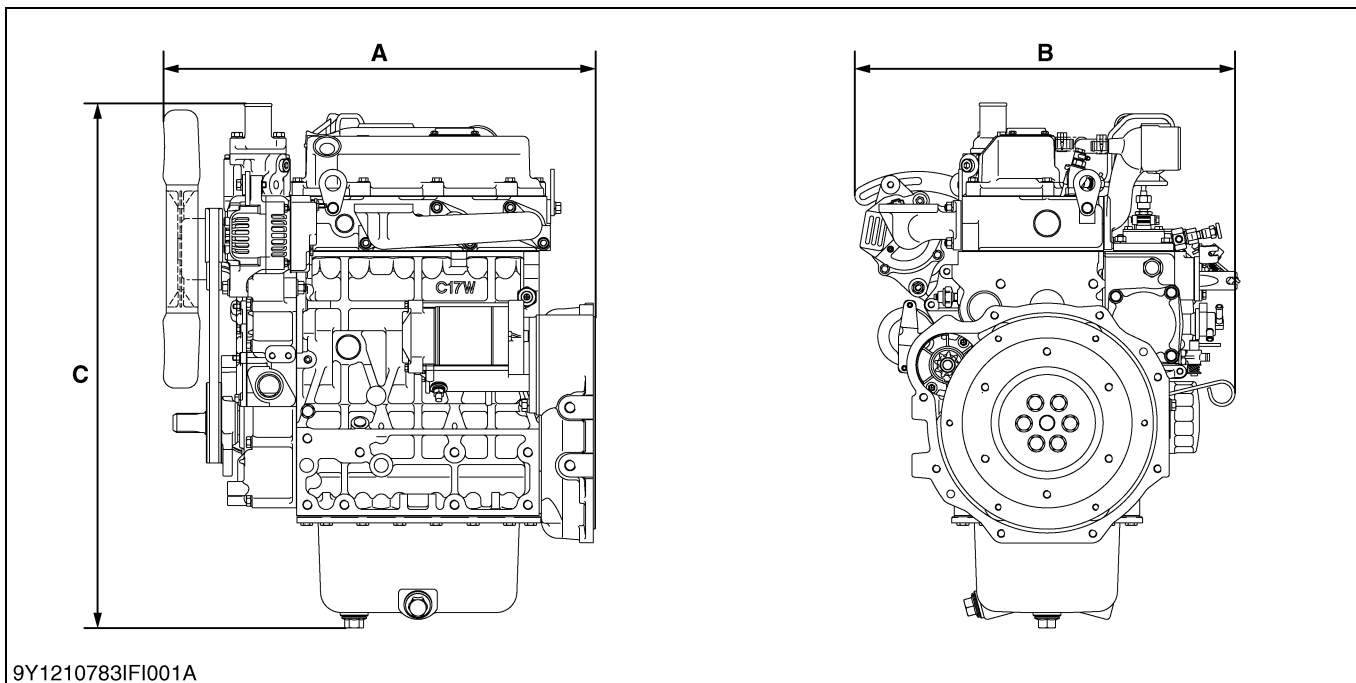

<b>D1703-M-DI-E4B</b>	
<b>A</b>	560.10 mm (22.051 in.)
<b>B</b>	499.00 mm (19.646 in.)
<b>C</b>	678.98 mm (26.731 in.)

9Y1210967INI0003US0

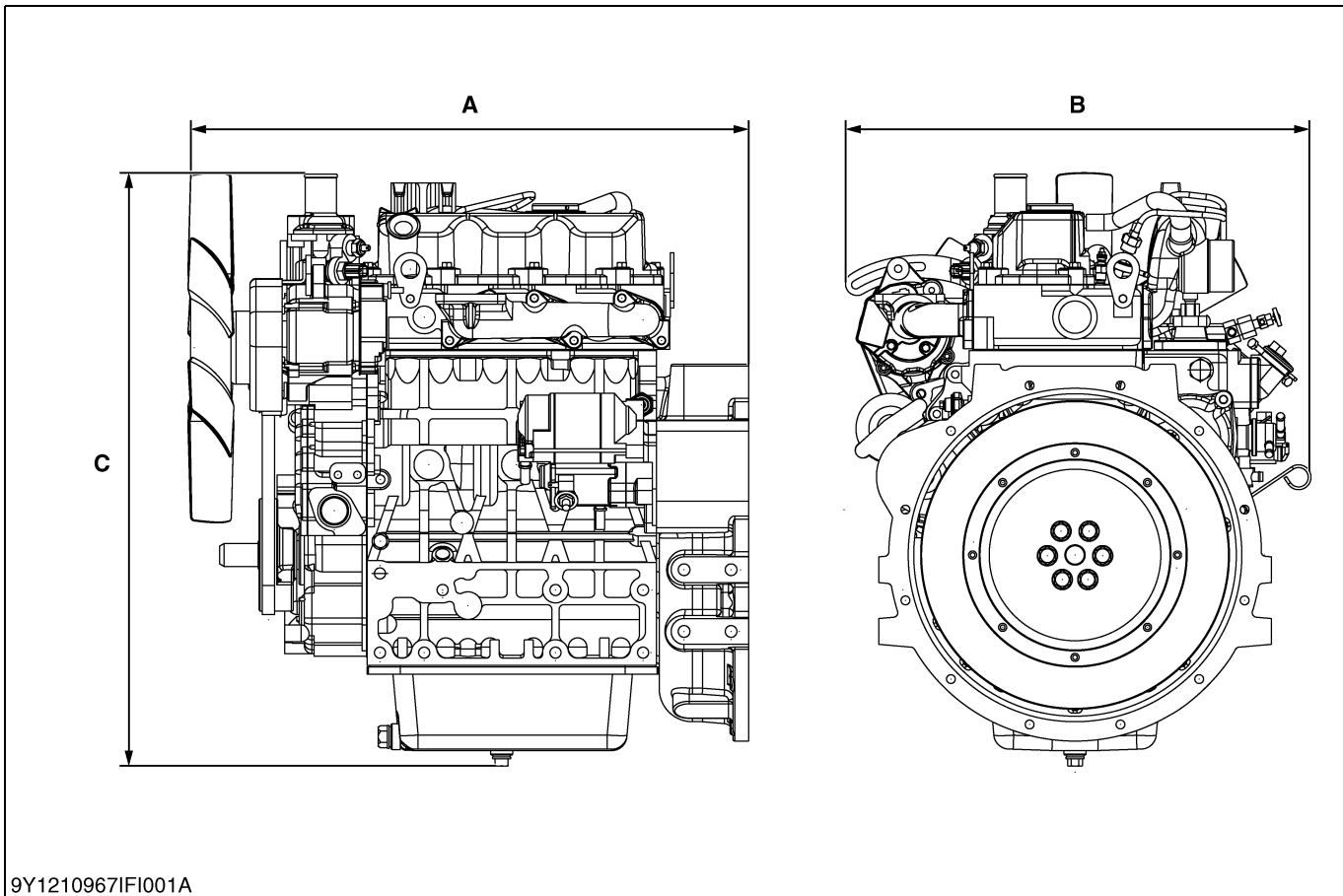

<b>D1503-M-E4BG</b>	
<b>A</b>	605.6 mm (23.84 in.)
<b>B</b>	505.0 mm (19.88 in.)
<b>C</b>	642.8 mm (25.31 in.)

9Y1210967INI0004US0

# **G GENERAL**



**Suggest:**

**For more complete manuals. Please go to the home page.**

**<https://www.ebooklibonline.com>**

**If the above button click is invalid. Please download this document first, and then click the above link to download the complete manual.**

**Thank you so much for reading**

# GENERAL

## CONTENTS

1. ENGINE IDENTIFICATION .....	G-1
[1] MODEL NAME AND ENGINE SERIAL NUMBER.....	G-1
[2] E4B ENGINE .....	G-3
[3] CYLINDER NUMBER.....	G-3
2. GENERAL PRECAUTIONS.....	G-4
3. MAINTENANCE CHECK LIST .....	G-5
4. CHECK AND MAINTENANCE .....	G-8
[1] DAILY CHECK POINTS .....	G-8
[2] CHECK POINTS FOR THE INITIAL 50 HOURS.....	G-10
[3] CHECK POINTS FOR EVERY 50 HOURS .....	G-11
[4] CHECK POINTS FOR EVERY 100 HOURS .....	G-12
[5] CHECK POINTS FOR EVERY 150 HOURS .....	G-14
[6] CHECK POINTS FOR EVERY 200 HOURS .....	G-15
[7] CHECK POINTS FOR EVERY 400 HOURS .....	G-18
[8] CHECK POINTS FOR EVERY 500 HOURS .....	G-20
[9] CHECK POINTS FOR EVERY 1 OR 2 MONTHS .....	G-22
[10]CHECK POINTS FOR EVERY YEAR.....	G-23
[11]CHECK POINTS FOR EVERY 800 HOURS .....	G-24
[12]CHECK POINTS FOR EVERY 1500 HOURS .....	G-25
[13]CHECK POINTS FOR EVERY 3000 HOURS .....	G-27
[14]CHECK POINTS FOR EVERY 2 YEARS.....	G-29
5. SPECIAL TOOLS .....	G-33

# 1. ENGINE IDENTIFICATION

## [1] MODEL NAME AND ENGINE SERIAL NUMBER

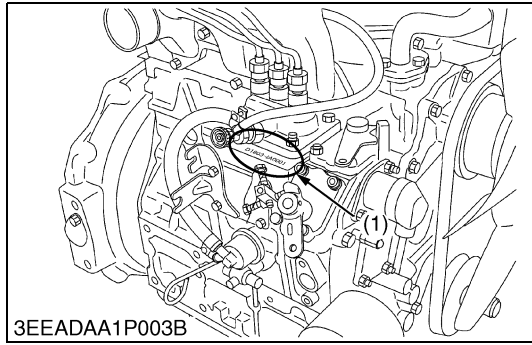

You must identify the engine model name and serial number before you start a job. When you get in touch with the manufacturer, always tell your engine model name and serial number.

### Engine Serial Number

The engine serial number is an identified number for the engine. It appears after the engine model name.

It shows the month and year of manufacture as below.

### Engine Series

Number or Alphabet	Series	Number or Alphabet	Series
1	05 (include: WG)	7	03
2	V3	8	07
3	08	A	EA, RK
4	SM (include: WG)	B	03 (KET Production)
5	Air Cooled Gasoline	C	V3, 07 (KEW Production)
6	GZ, OC, AC, EA, E		

### Production Year

Alphabet or Number	Year	Alphabet or Number	Year
1	2001	F	2015
2	2002	G	2016
3	2003	H	2017
4	2004	J	2018
5	2005	K	2019
6	2006	L	2020
7	2007	M	2021
8	2008	N	2022
9	2009	P	2023
A	2010	R	2024
B	2011	S	2025
C	2012	T	2026
D	2013	V	2027
E	2014		

(1) Engine Model Name and Serial Number

**(To be continued)**

**<https://www.ebooklibonline.com>**

Hello dear friend!

Thank you very much for reading.

Enter the link into your browser.

The full manual is available for immediate download.

**<https://www.ebooklibonline.com>**