

010 COMPLETE ENGINE

Pos.	Part No.	Description	Dimension	Quantity	Conditions
1	77 0006 150 5	ENGINE		1	1)
1	77 0006 150 6	ENGINE	BF 6M 1013FC 186KW	1	2)
1	00 1115 118 0	ENGINE	TIER DEUTZ BF6M1013FC	1	3)
1	00 1150 541 0	ENGINE	TIER 2	1	4)
1	00 1150 722 0	ENGINE		1	5)
1	00 1147 212 0	ENGINE	Z.B. ORIGINALMOTOR 107666	1	6)
<hr/>					
1)	Homologationtype			+ 4522 226 CH	
<hr/>					
2)	Homologationtype			+ 4532 250 CH	
<hr/>					
3)	Homologationtype			+ 4552 270 CH	
<hr/>					
4)	Homologationtype			+ 4522 Exchange / Reman	
<hr/>					
5)	Homologationtype			+ 4532 Exchange / Reman	
<hr/>					
6)	Homologationtype			+ 4552 Exchange / Reman	
<hr/>					

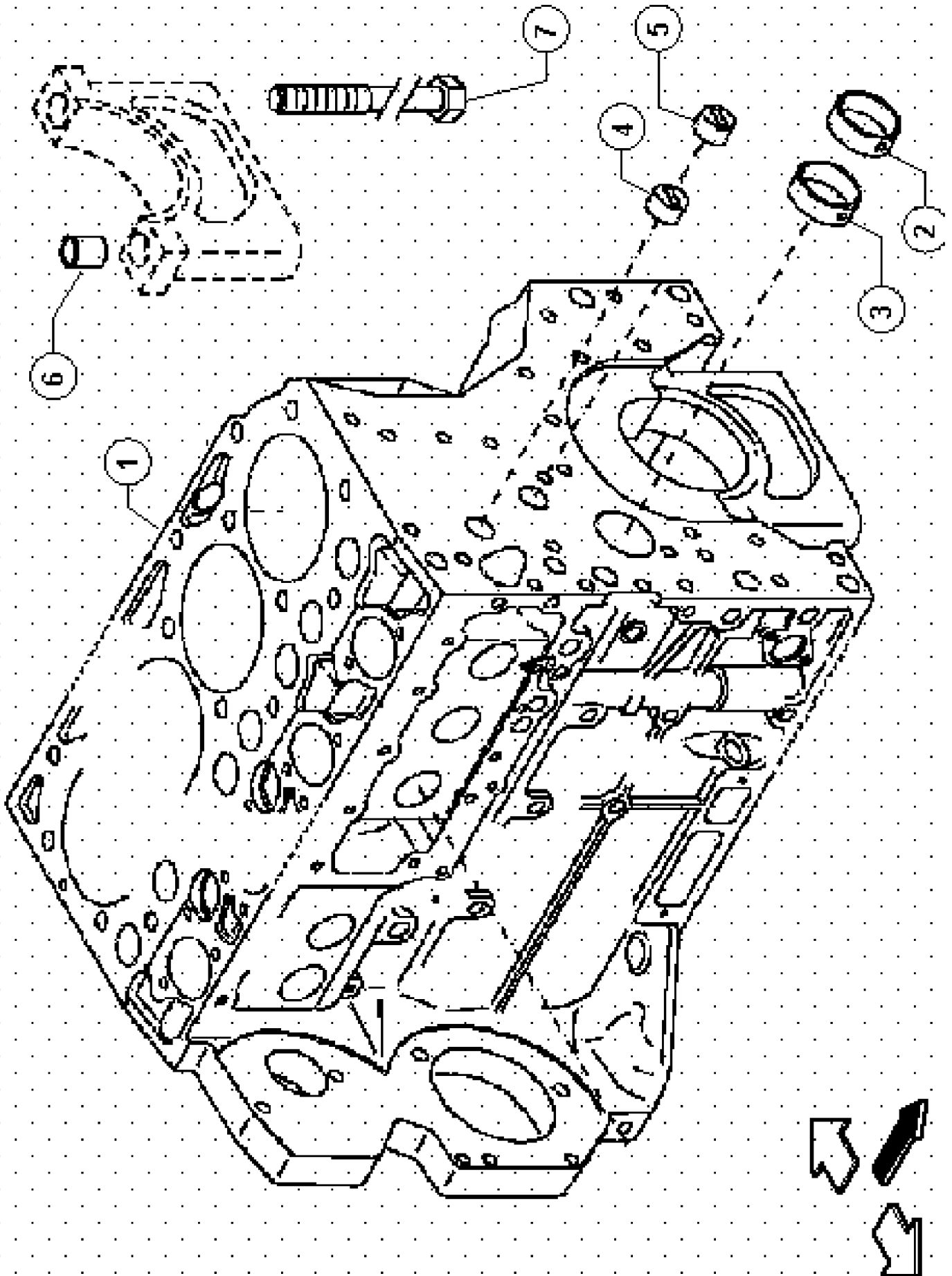

<https://www.ebooklibonline.com>

Hello dear friend!

Thank you very much for reading.

Enter the link into your browser.

The full manual is available for immediate download.

<https://www.ebooklibonline.com>

100 CRANKCASE

Pos.	Part No.	Description	Dimension	Quantity	Conditions
1	00 1131 062 0	CRANKCASE		1	
2	60 0502 628 0	RING		6	
3	60 0502 628 1	RING		1	
4	60 0502 628 2	SLEEVE		1	
5	60 0502 628 3	BUSHING		1	
6	60 0502 628 4	BUSHING		14	
7	60 0502 628 5	SCREW		14	

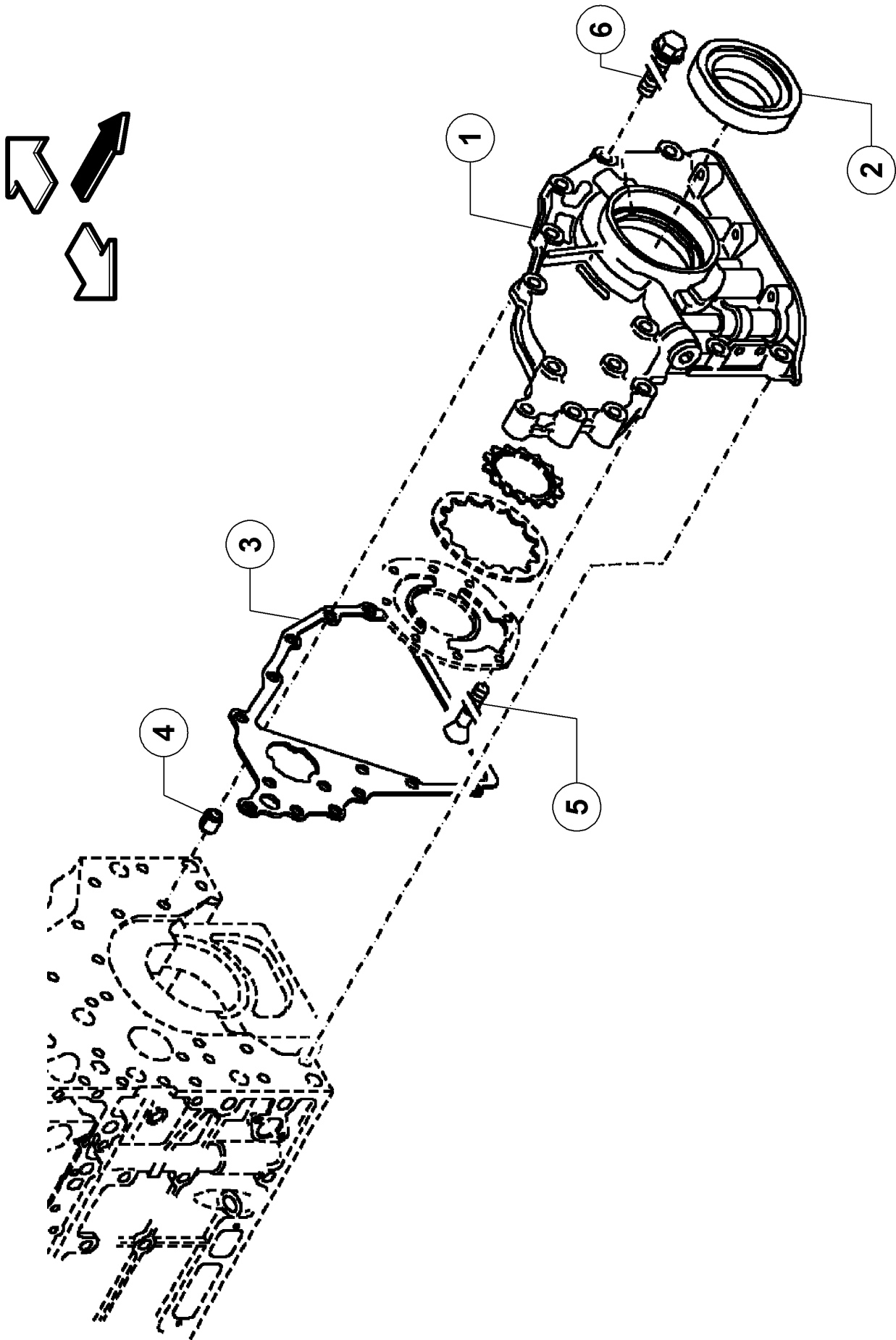

100 CRANKCASE

Pos.	Part No.	Description	Dimension	Quantity	Conditions
1	00 1138 069 0	COVER		1	
2	60 0502 628 7	SEAL RING		1	
3	00 1133 967 0	SEAL RING		1	
4	60 0502 628 9	SLEEVE		1	
5	60 0502 629 0	SCREW	M 6X 16	8	
6	60 0502 629 1	HEXAGON HEAD BOLT	M8X35-F	14	

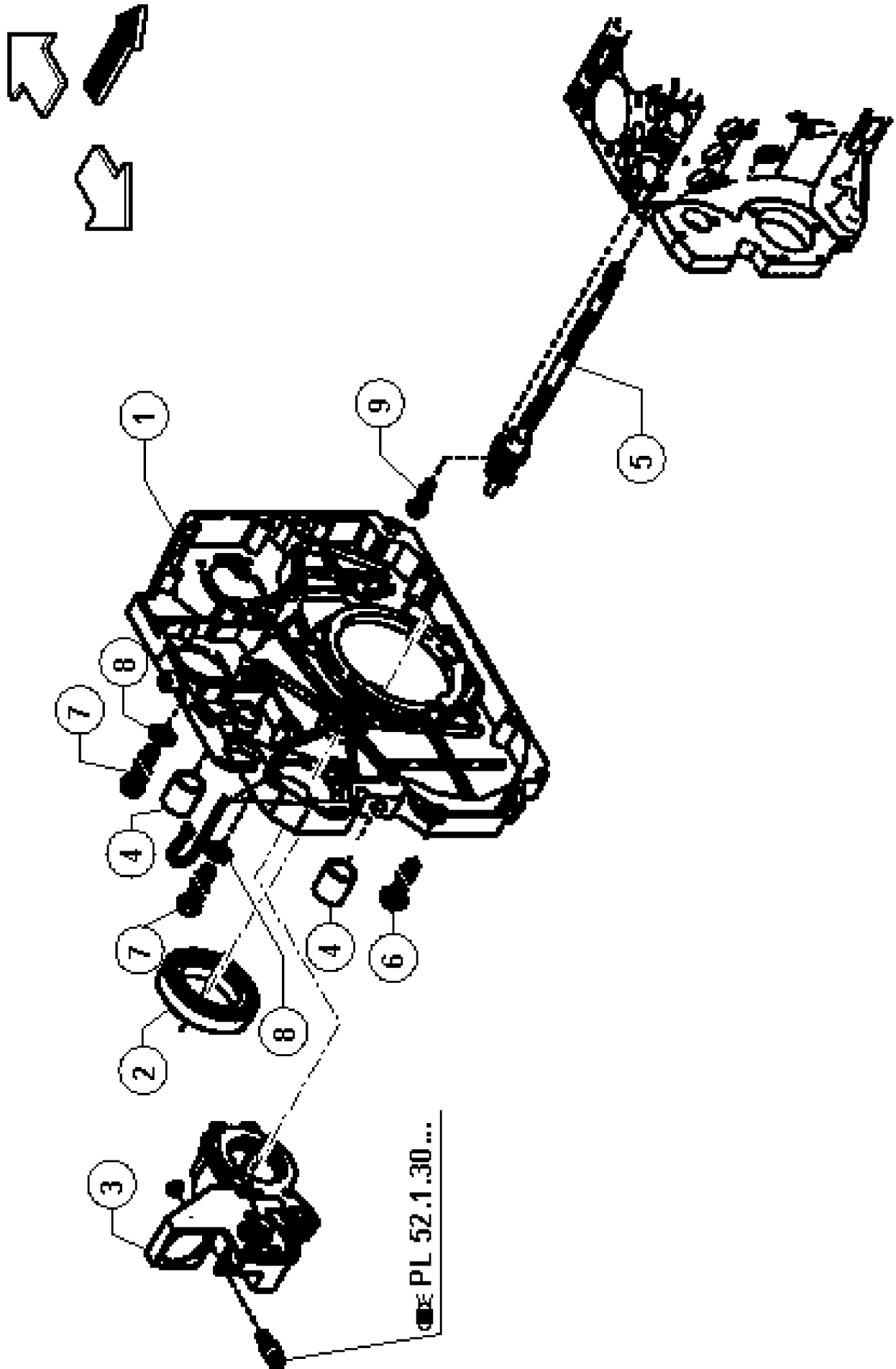

120 TIMING CASE

Pos.	Part No.	Description	Dimension	Quantity	Conditions
1	00 1138 076 0	HOUSING		1	
2	60 0502 631 0	SEAL RING		1	
3	00 1135 063 0	REGULATOR		1	
4	60 0502 631 1	BUSHING		2	
5	60 0502 631 2	ROD		1	
6	60 0502 629 1	HEXAGON HEAD BOLT	M8X35-F	12	
7	60 0502 631 7	SCREW		2	
8	60 0502 631 8	WASHER	A17	2	
9	60 0502 631 5	SCREW		1	

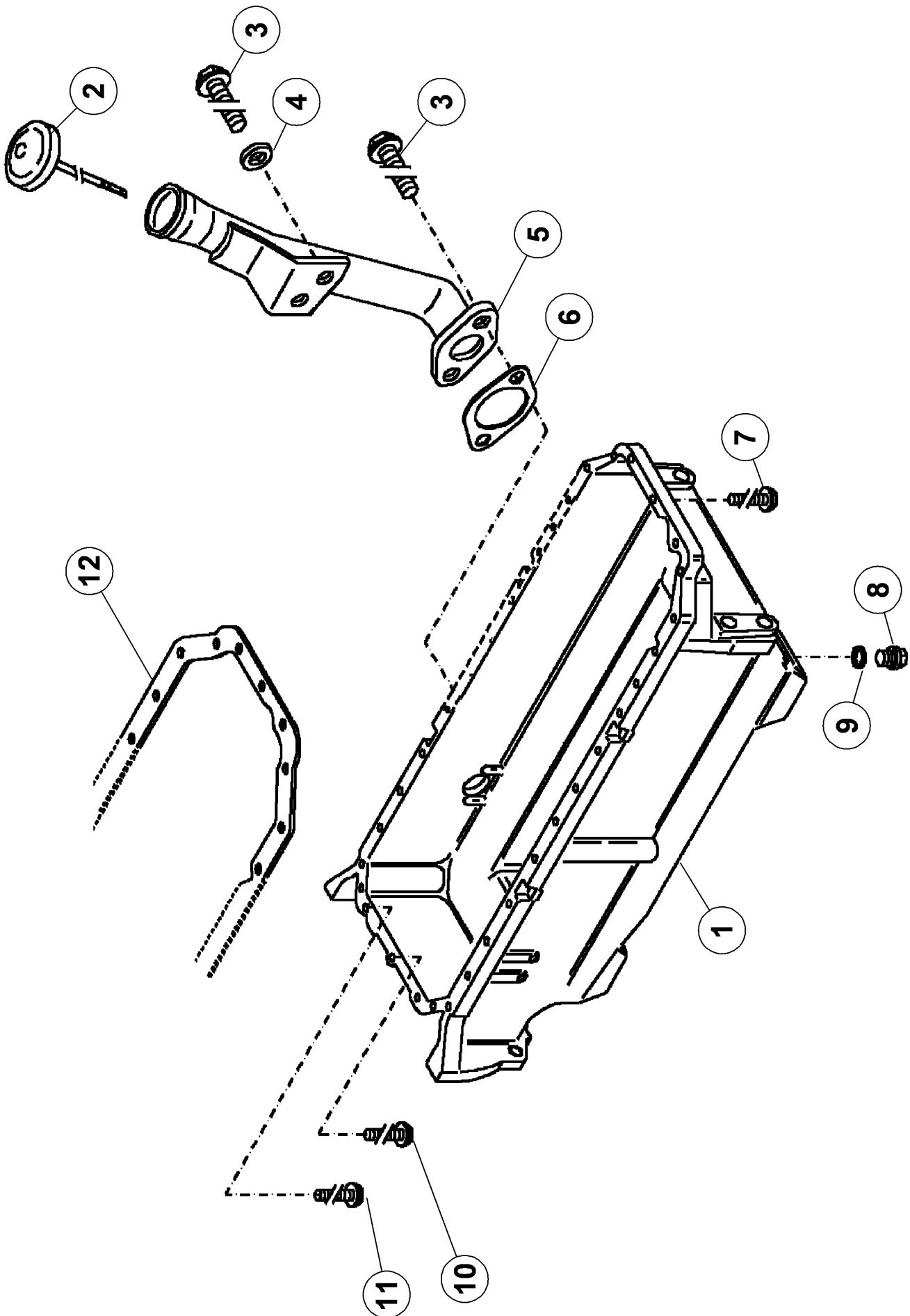

160 OIL PAN

Pos.	Part No.	Description	Dimension	Quantity	Conditions
1	60 0502 631 9	OIL SUMP		1	
2	60 0502 632 5	LOCK		1	
3	60 0502 631 5	SCREW		3	
4	60 0502 633 0	WASHER		1	
5	60 0502 632 3	TUBE		1	
6	60 0502 632 4	SEALING RING	35X58X1,5	1	
7	60 0502 629 1	HEXAGON HEAD BOLT	M8X35-F	27	
8	00 1131 076 0	PLUG		1	
9	60 0502 632 1	SEALING RING	18X24-1,34	1	
10	60 0502 632 8	SCREW	M08X130-F	1	
11	60 0502 632 7	HEXAGON HEAD SCREW	M08X140-F	6	
12	60 0502 632 2	GASKET		1	

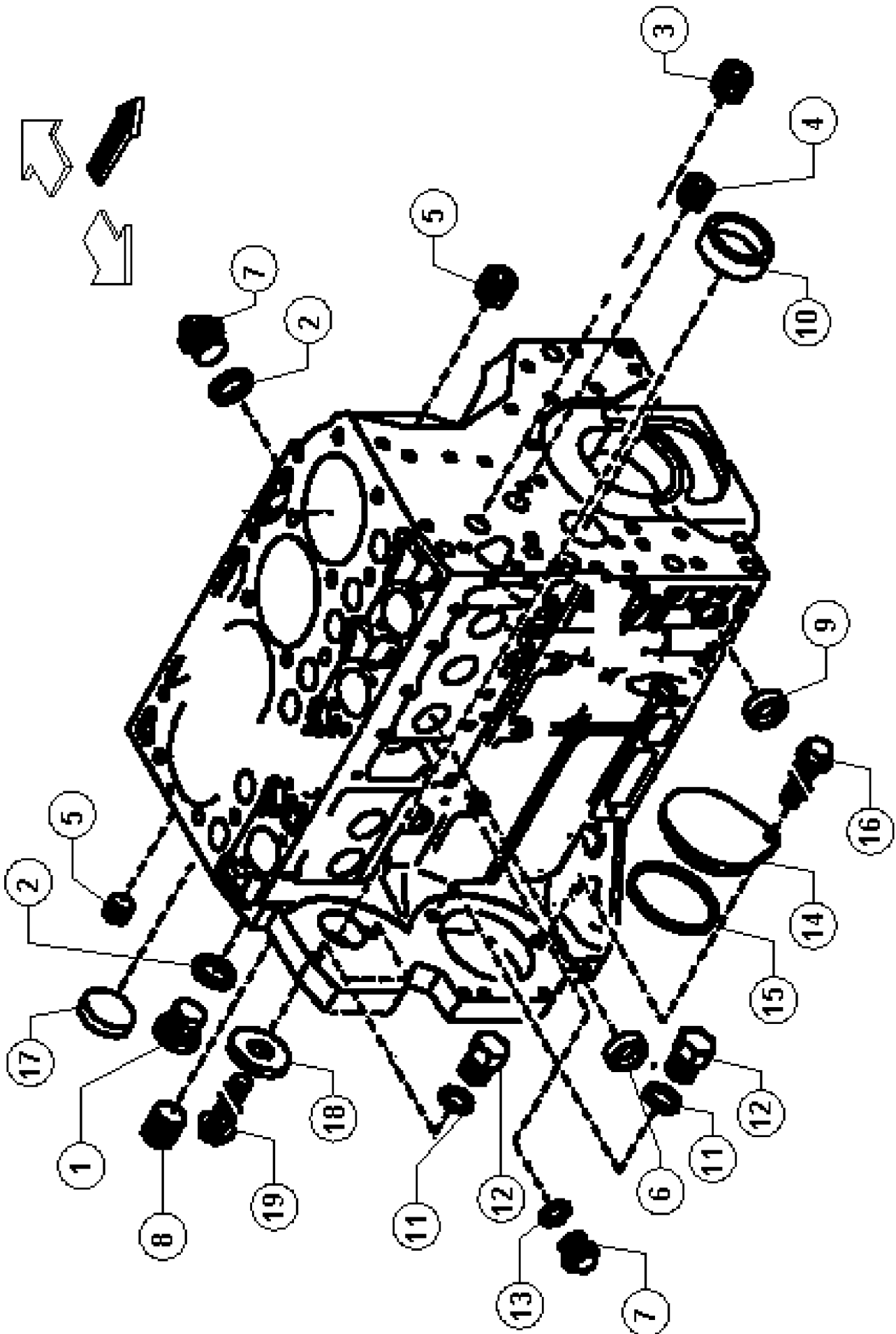

180 PLUGS

Pos.	Part No.	Description	Dimension	Quantity	Conditions
1	60 0502 629 3	LOCK		2	
2	60 0500 090 3	SEALING RING		4	
3	60 0502 629 4	PLUG		1	
4	60 0502 629 5	LOCK		1	
5	60 0502 629 6	LOCK		2	
6	60 0502 629 7	LOCK		10	
7	60 0502 629 8	PLUG	A-M14X1,5	2	
8	60 0502 629 9	LOCK		1	
9	60 0502 630 0	LOCKING COVER	A 36	1	
10	60 0502 630 1	LOCK		1	
11	60 0502 680 3	WASHER		3	
12	60 0502 630 2	LOCK		3	
13	60 0500 092 9	SEALING RING		1	
14	60 0503 060 5	COVER		1	
15	60 0502 630 4	O-RING	96 X 4	1	
16	60 0502 630 5	SCREW	F-M10X 20	1	
17	60 0502 630 6	COVER		1	
18	60 0502 630 7	WASHER		1	
19	60 0502 630 8	SCREW		1	

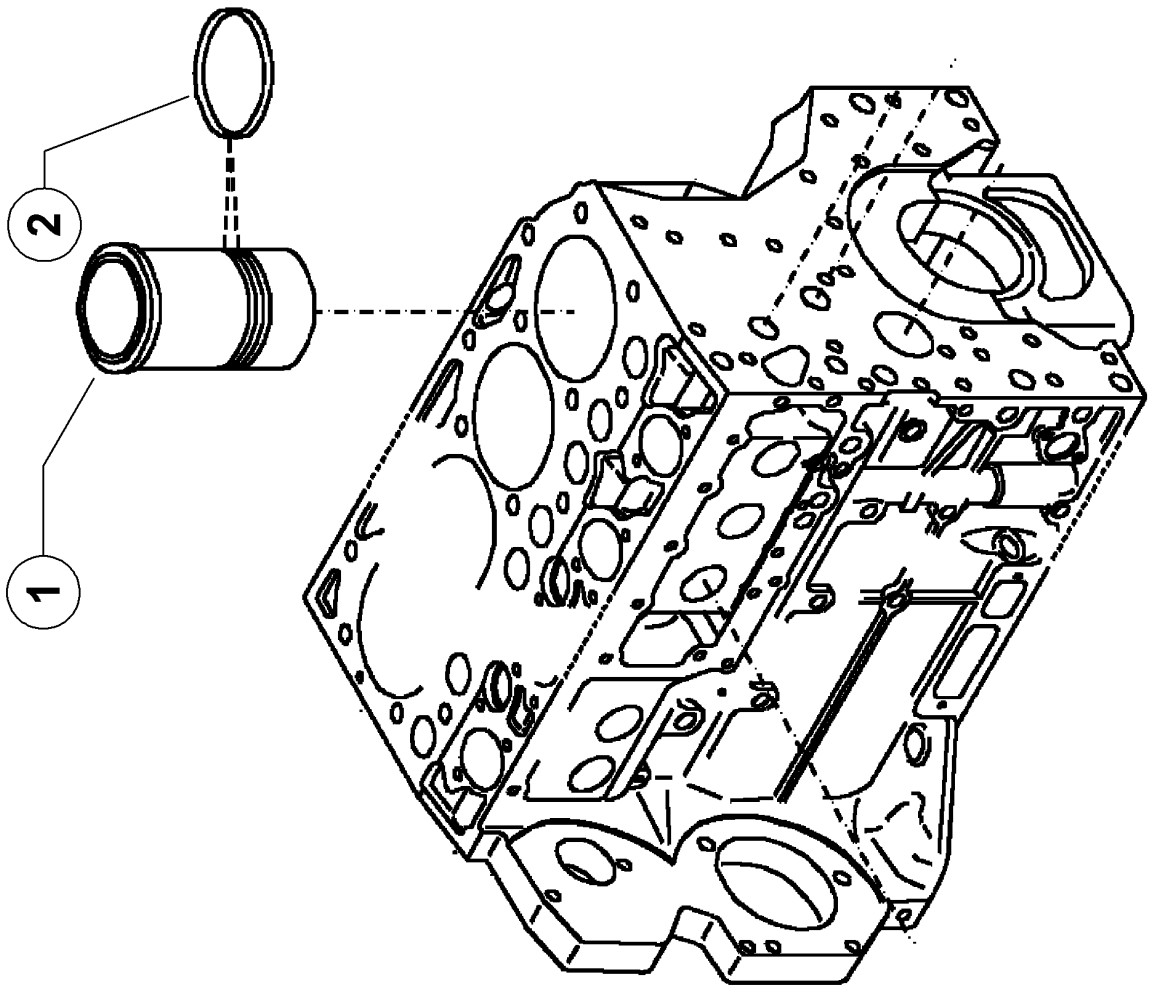
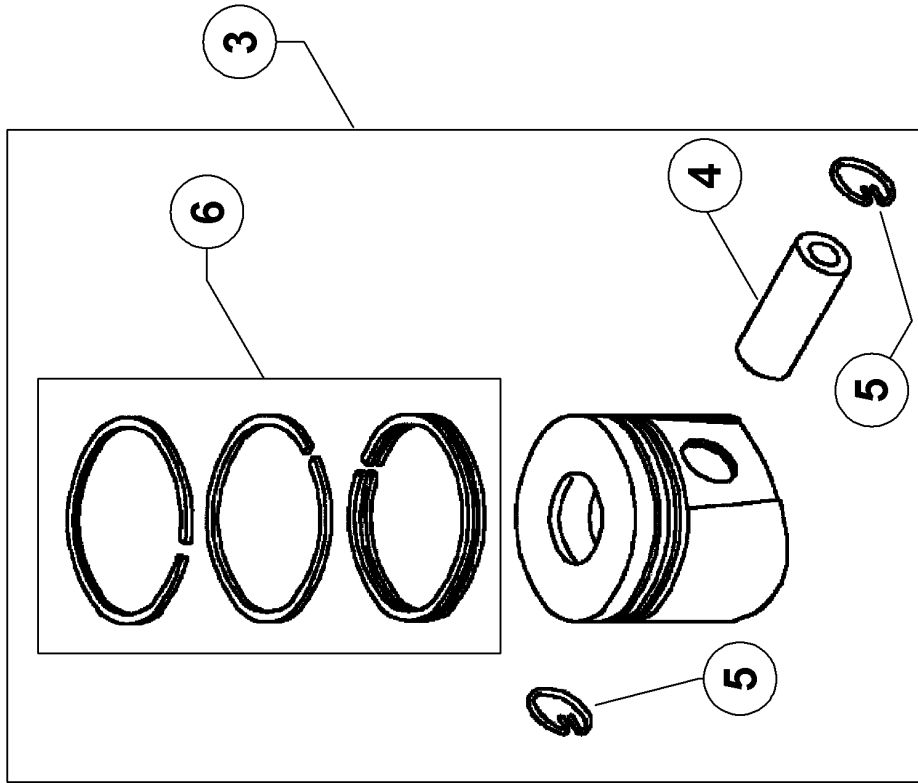
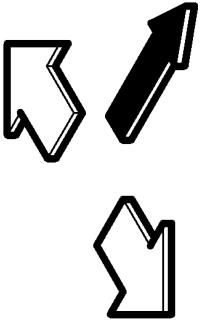

100 CYLINDER LINER, PISTON

Pos.	Part No.	Description	Dimension	Quantity	Conditions
1	60 0503 069 3	CYLINDER LINER		6	
2	60 0502 633 2	O-RING	112 X 3	12	
3	00 1138 340 0	CYLINDER PISTON		6	
4	60 0502 633 4	PISTON BOLT		6	
5	60 0502 633 5	INT RETAINING RING	42 X 1,75	2	
6	00 1138 863 0	SET OF PISTON RINGS		6	

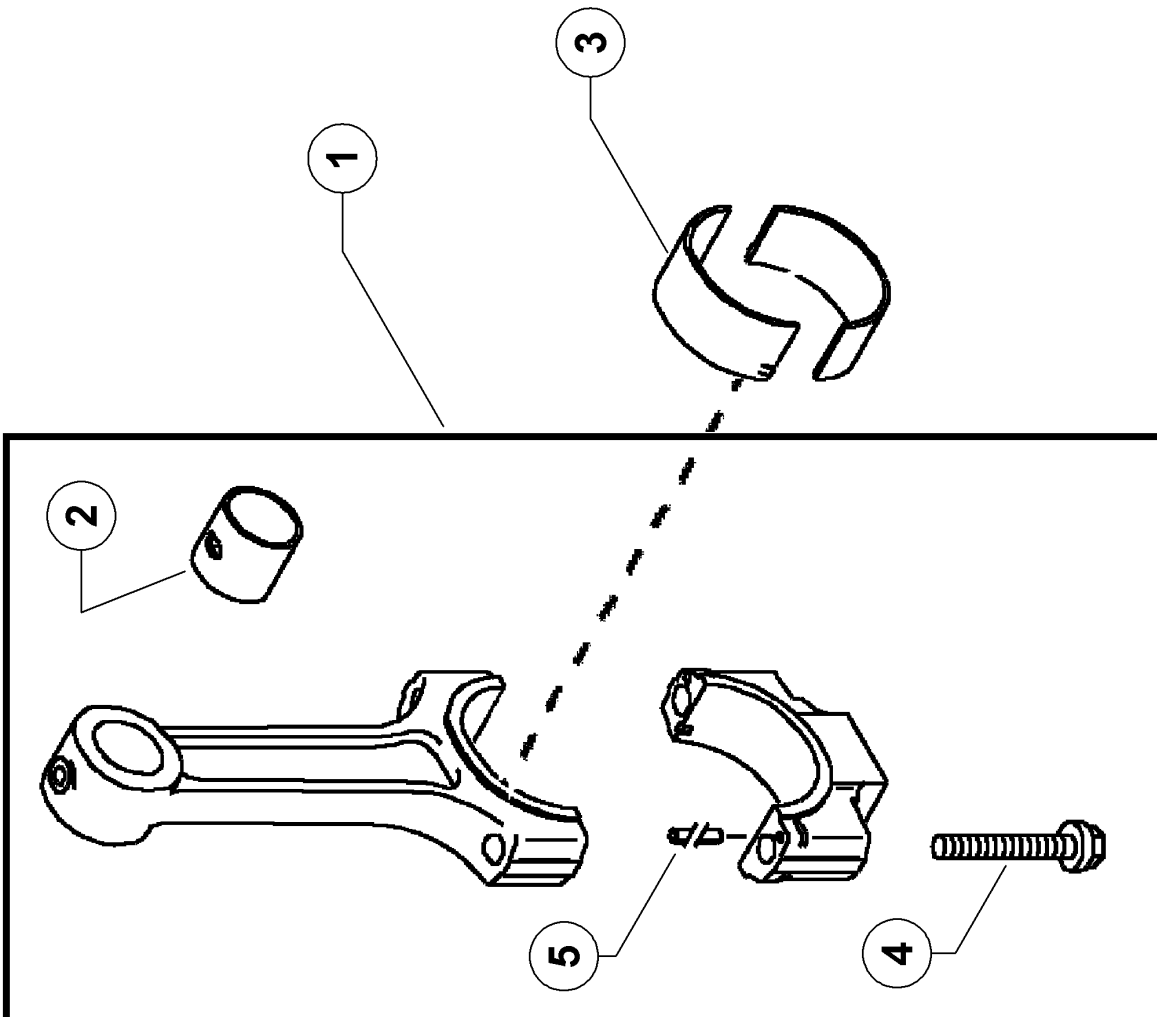

120 CONNECTING ROD, CONNECTING ROD BEARINGS

Pos.	Part No.	Description	Dimension	Quantity	Conditions
1	00 1131 072 0	ROD (ENGINE)		6	
2	60 0502 634 0	RING		6	
3	00 1131 073 0	BEARING		6	1)
3	00 1138 353 0	BEARING BOX		6	2)
3	00 1138 354 0	BEARING		6	3)
4	60 0502 634 4	SCREW		12	
5	60 0502 634 5	PIN		12	
1)	Remarks		DI.68mm		
2)	Remarks		DI .67.75mm		
3)	Remarks		DI.67,50mm		

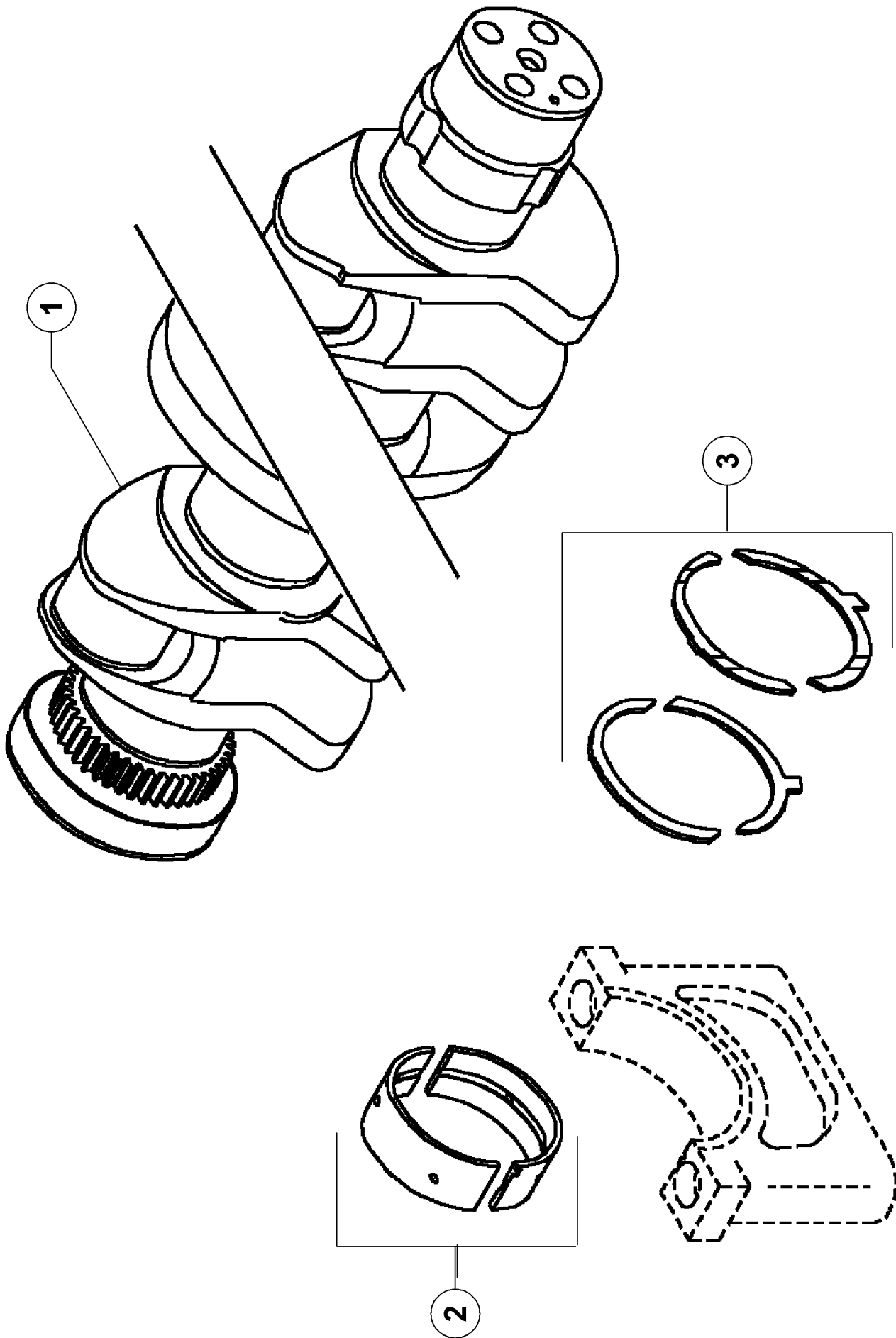

140 CRANKSHAFT

Pos.	Part No.	Description	Dimension	Quantity	Conditions
1	00 1135 965 0	CRANKSHAFT		1	
2	00 1144 843 0	BEARING		7	1)
2	60 0502 635 0	BEARING/CRANK		7	2)
2	60 0502 635 1	BEARING		7	3)
3	60 0502 634 8	STOP		1	4)
3	00 1145 023 0	WASHER		2	5)
1)	Remarks		Std.(85mm)		
2)	Remarks		84,75mm		
3)	Remarks		84,5mm		
4)	Remarks		Std.(2,9mm)		
5)	Remarks		3,1mm		

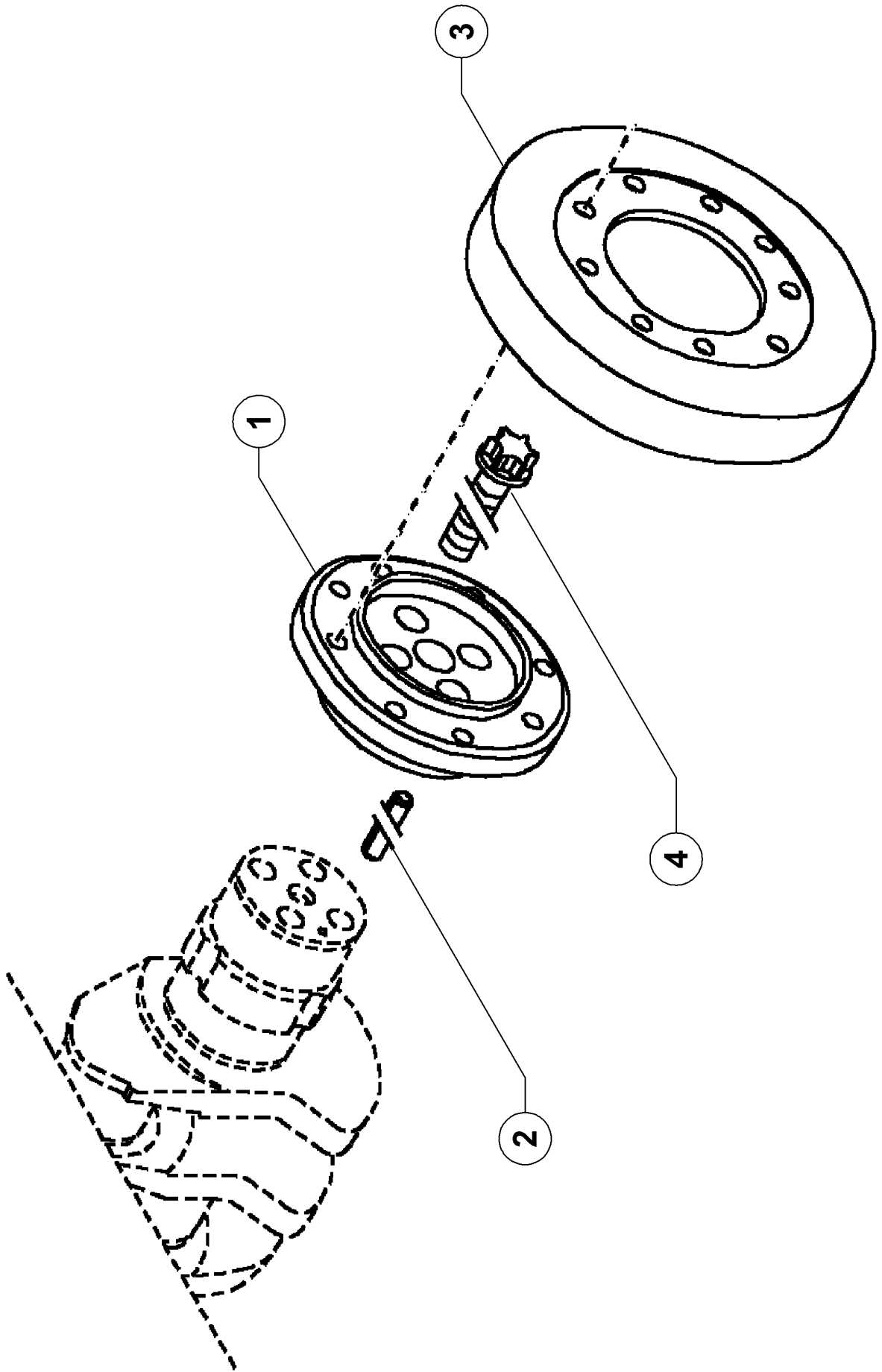

140 CRANKSHAFT

Pos.	Part No.	Description	Dimension	Quantity	Conditions
1	60 0502 635 3	FLANGE		1	
2	60 0502 635 4	BUSHING		1	
3	60 0502 635 5	ANTI-VIBRATION WHEEL		1	
4	60 0503 083 9	SCREW	B M16X1, 5X80-AUS-6RD E20	4	

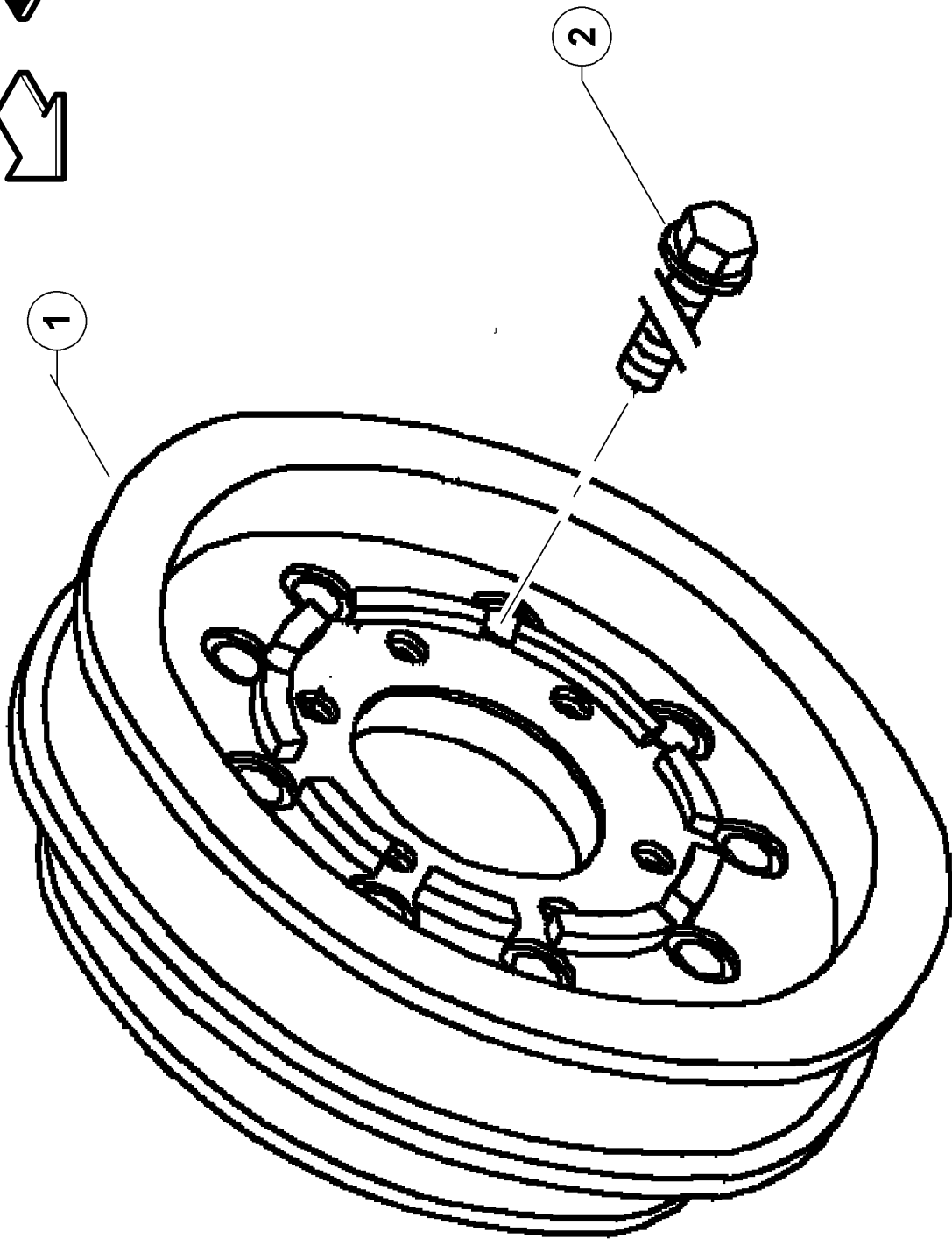
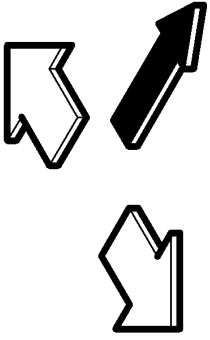

161 CRANKSHAFT PULLEY WHEEL

Pos.	Part No.	Description	Dimension	Quantity	Conditions
1	60 0502 655 9	V-BELT PULLEY		1	
2	77 0005 997 8	HEXAGON HEAD BOLT	M10X40	9	

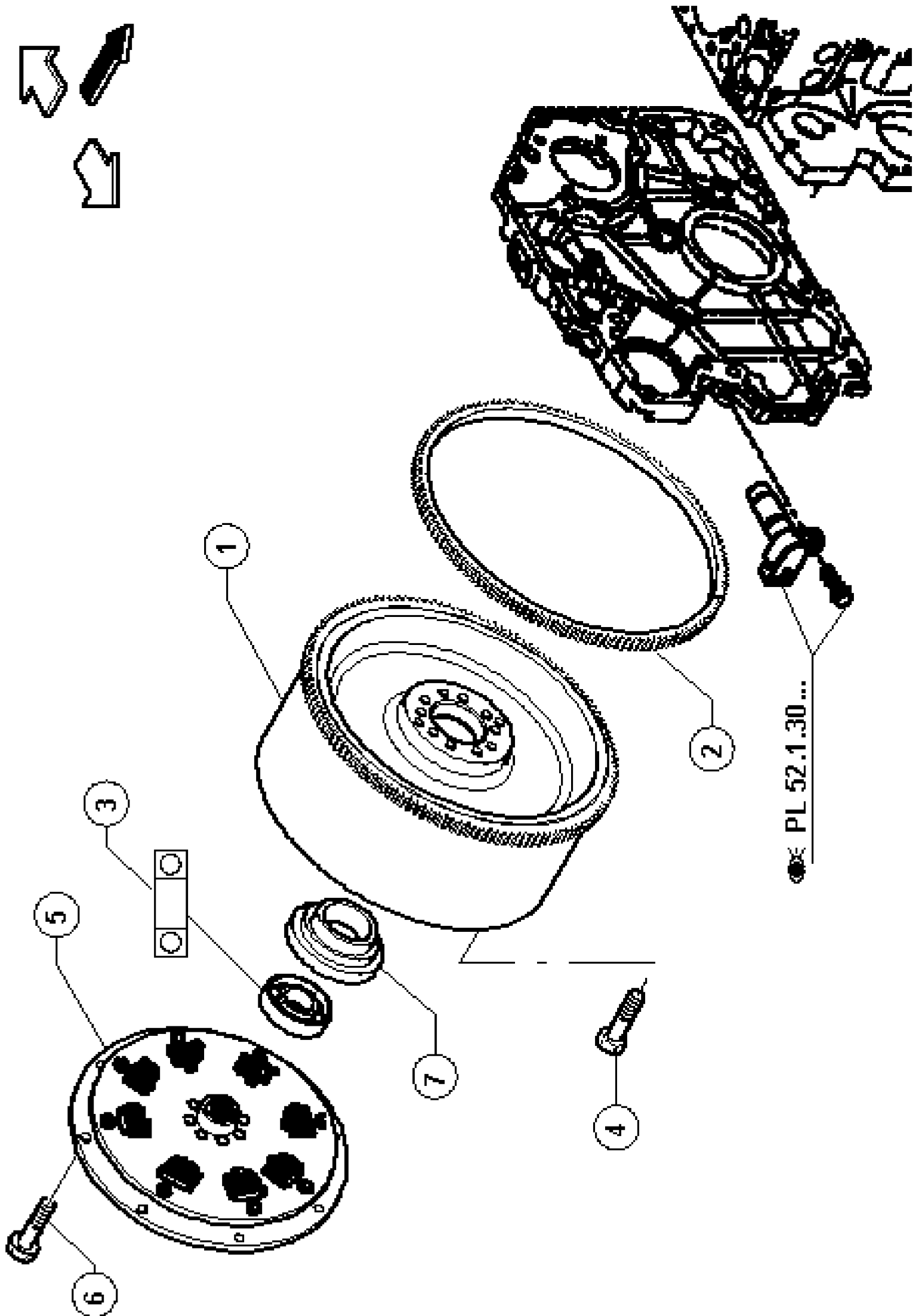

220 FLYWHEEL

Pos.	Part No.	Description	Dimension	Quantity	Conditions
1	77 0005 360 0	FLYWHEEL		1	
2	00 1134 889 0	TOOTHED RIM		1	
3	07 7062 062 3	BEARING-1 BALL		1	1)
4	77 0005 426 6	SCREW		10	2)
5	77 0005 363 7	TORSION DAMPER		1	
6	77 0005 997 8	HEXAGON HEAD BOLT	M10X40	8	3)
7	77 0006 562 7	BUSHING		1	
1)	Remarks		30X62X16		
2)	Remarks		10x100-105/12,9		
3)	Remarks		M10X150-40		

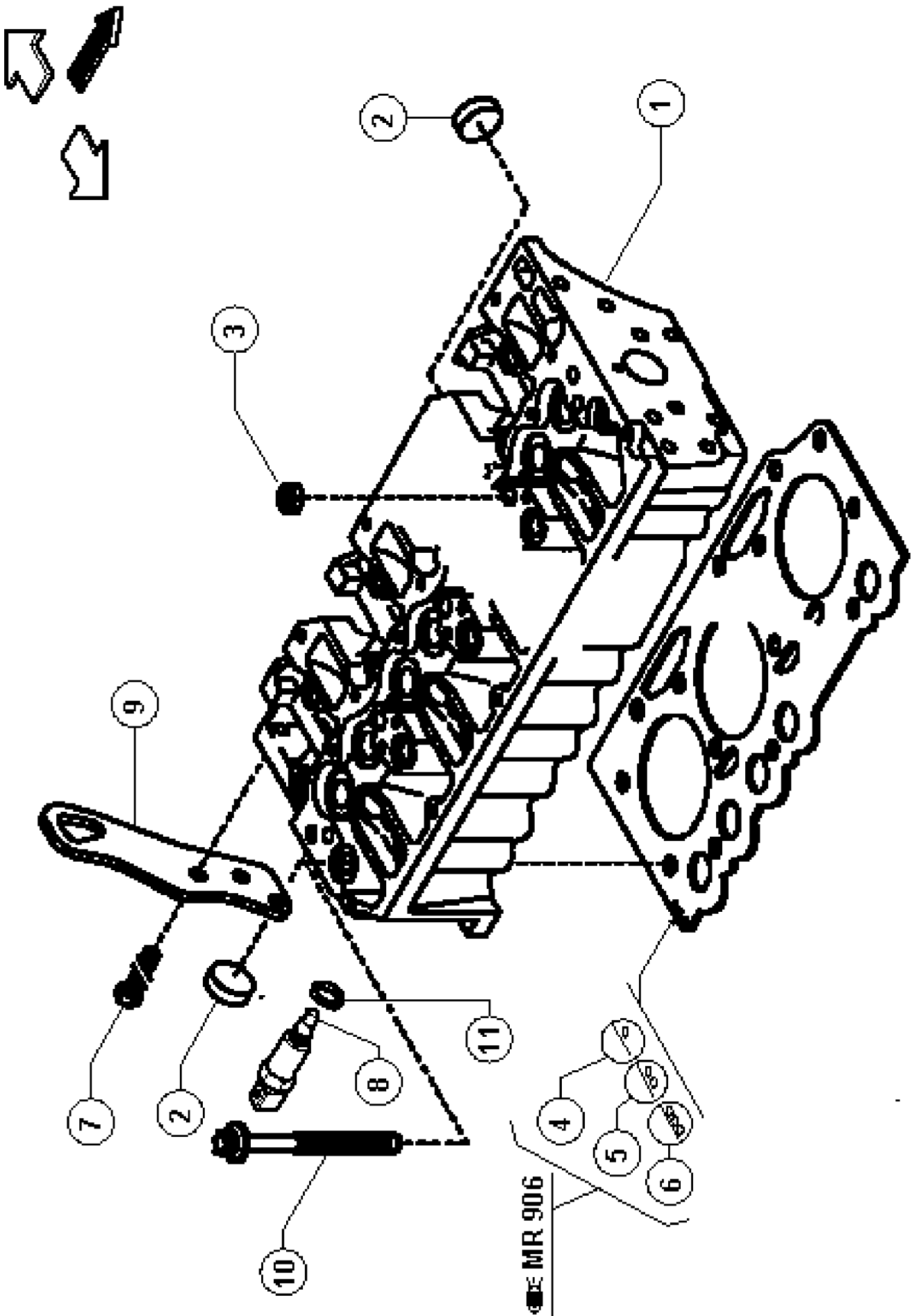

100 CYLINDER HEAD

Pos.	Part No.	Description	Dimension	Quantity	Conditions
1	60 0502 636 0	CYLINDER HEAD		1	
2	60 0502 630 0	LOCKING COVER	A 36	5	
3	60 0502 636 2	LOCK		5	
4	60 0502 636 3	CYLINDER HEAD GASKET		1	
5	60 0502 636 4	CYLINDER HEAD GASKET		1	
6	60 0502 636 5	CYLINDER HEAD GASKET		1	
7	60 0502 636 8	SCREW		3	
8	77 0005 893 5	SENSOR		1	1)
9	60 0502 636 6	SUPPORT		1	
10	60 0502 636 7	SCREW		26	
11	77 0007 639 2	SEAL RING		1	2)
1)	Remarks		TEMP EAU		
2)	Remarks		14X18-1,50		

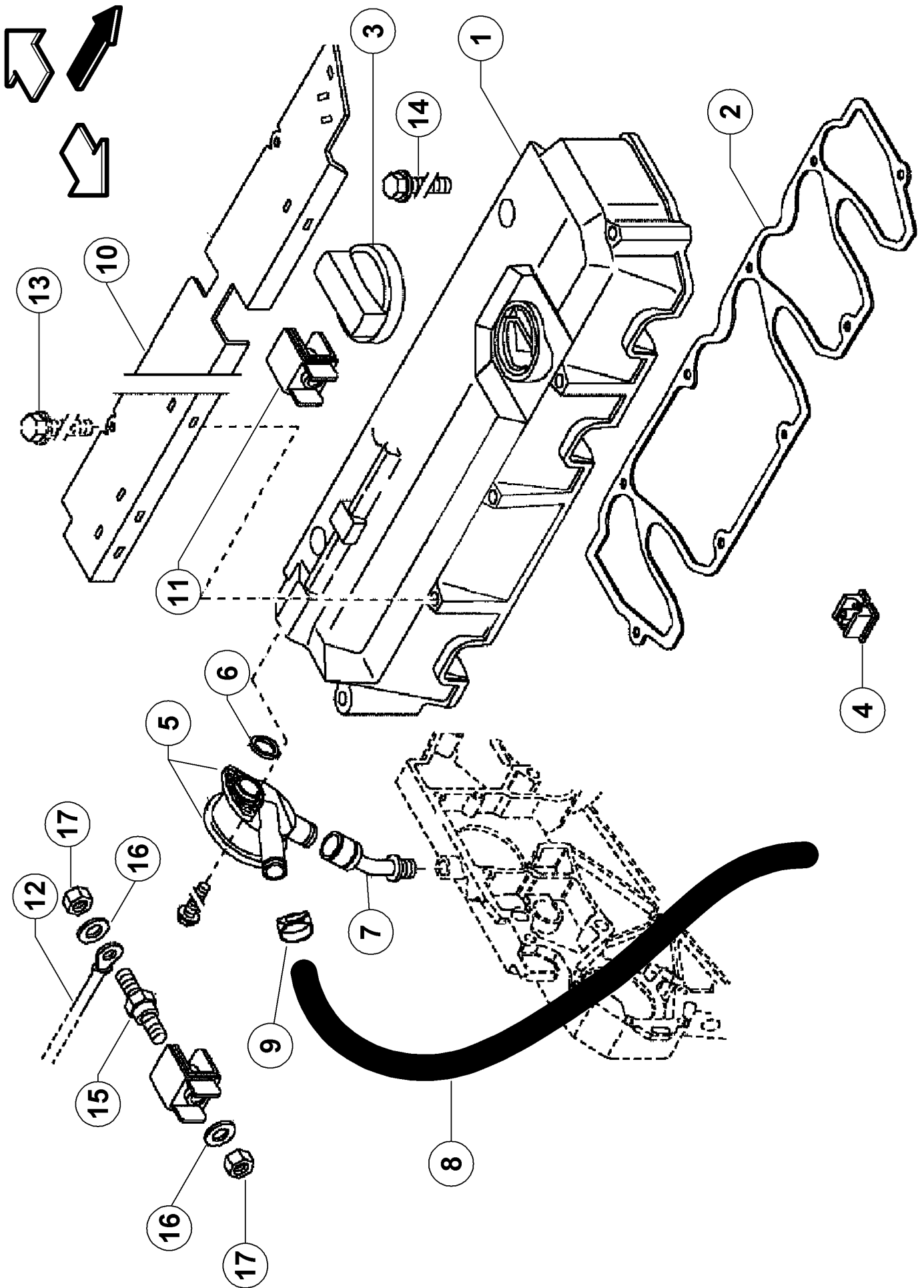

120 CYLINDER HEAD COVER

Pos.	Part No.	Description	Dimension	Quantity	Conditions
1	60 0503 048 3	COVER		1	
2	60 0503 009 4	SEAL RING		1	
3	60 0502 637 0	LOCKING COVER		1	
4	60 0502 637 1	COVER		1	
5	60 0502 637 2	REGULATOR		1	
6	60 0502 637 3	SEAL RING		1	
7	60 0502 637 4	RUBBER HOSE		1	
8	00 1120 252 0	BREATHER		1	1)
9	60 0502 637 6	CLAMP	A-29X15	1	
10	60 0502 637 7	PLATE		1	
11	60 0502 637 8	STRIP		2	
12	60 0502 637 9	WIRE		1	
13	60 0502 638 0	SCREW		13	2)
14	60 0502 980 6	SCREW	F-M 6X20	2	3)
15	60 0502 638 2	STUD		2	
16	60 0502 638 3	WASHER	6 -6,4X12X1,6	4	
17	60 0502 638 4	NUT	M06	4	

1)	Remarks	Lo.1250mm
2)	Remarks	HM 6X1.00-95
3)	Remarks	HM 6 X1.00-20

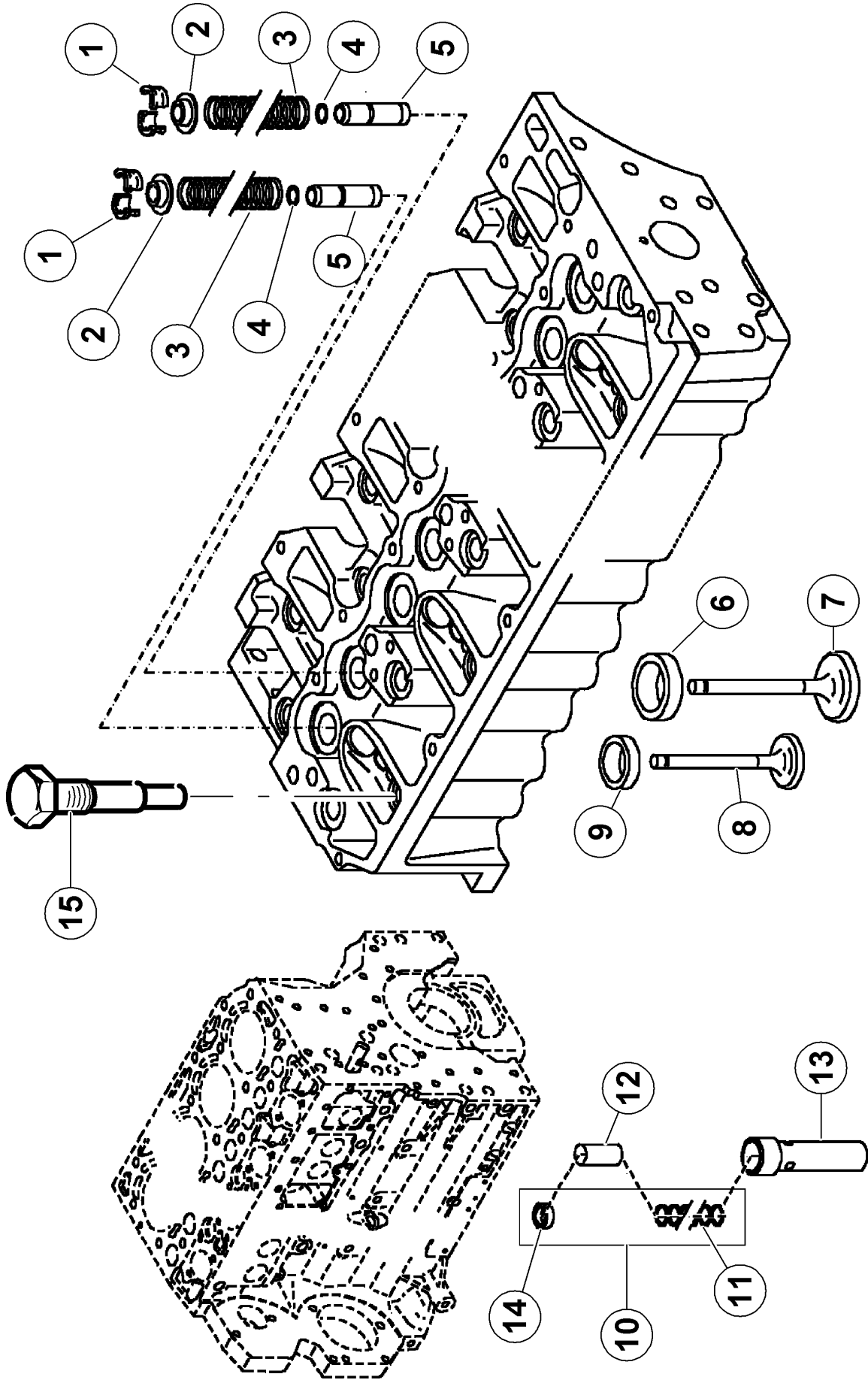

140 VALVES

Pos.	Part No.	Description	Dimension	Quantity	Conditions
1	60 0502 638 5	HALF-CONE		24	
2	60 0502 638 6	WASHER		12	
3	60 0502 638 7	SPRING		12	
4	60 0502 638 8	O-RING	9X1,5	12	
5	60 0502 638 9	GUIDE		12	
6	60 0502 639 0	VALVE SEAT		6	1)
7	60 0503 153 8	ENGINE VALVE		6	1)
8	60 0503 153 9	ENGINE VALVE		6	2)
9	60 0502 639 3	VALVE SEAT		6	2)
10	60 0502 639 4	VALVE		1	
11	60 0502 639 5	SPRING		1	
12	60 0502 639 6	ROD		1	
13	60 0502 639 7	BUSHING		1	
14	60 0502 639 8	SHAFT SEAL		1	
15	60 0503 060 4	SCREW		6	

1) Remarks	ADM
-------------------	-----

2) Remarks	ECH
-------------------	-----

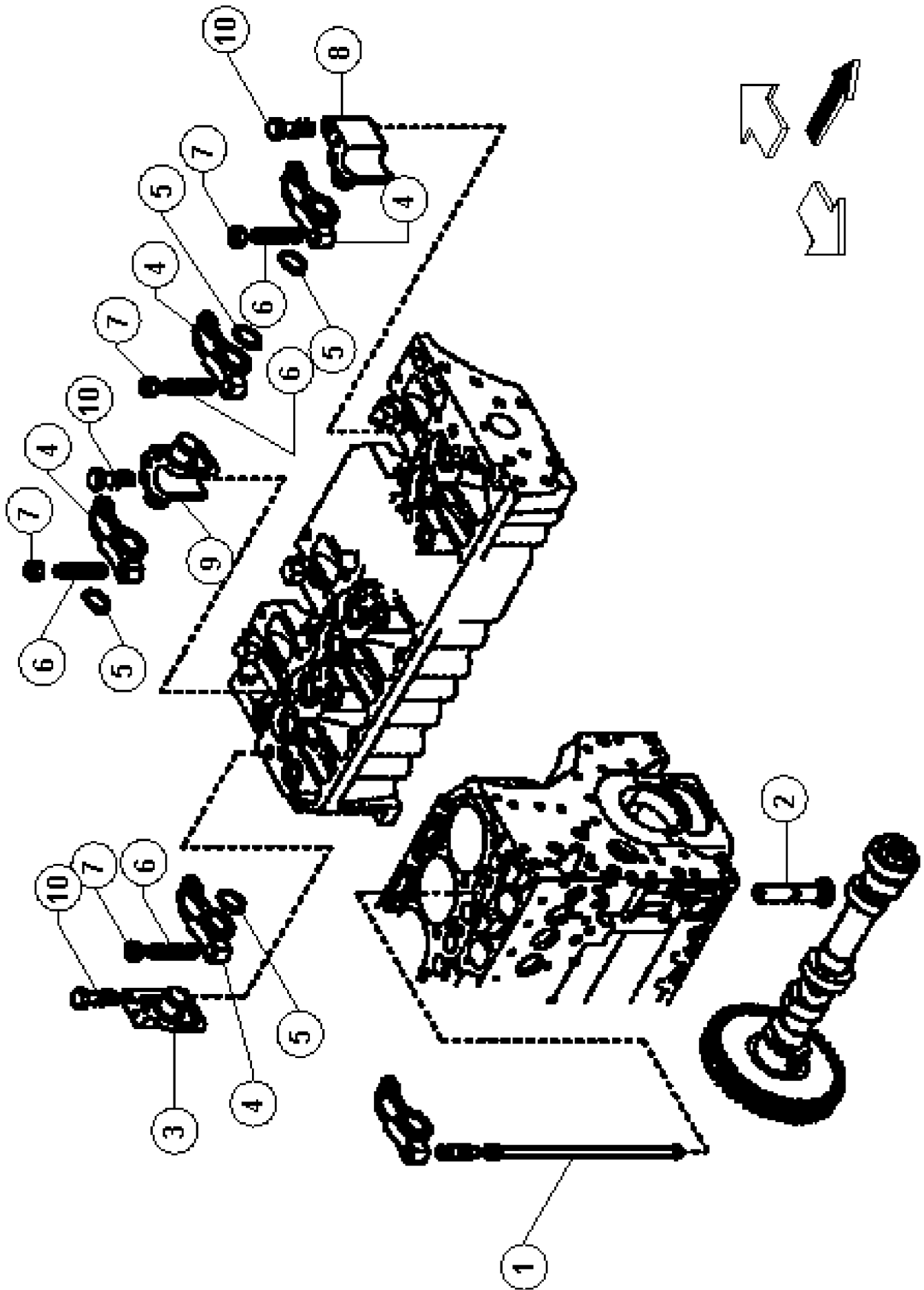

160 ROCKER ARM

Pos.	Part No.	Description	Dimension	Quantity	Conditions
1	60 0502 639 9	ROD		12	
2	60 0502 640 0	PUSH BUTTON		12	
3	60 0502 640 1	SUPPORT		1	
4	60 0502 640 2	ROCKER ARM		12	
5	60 0502 640 3	CIRCLIP	21 X 1,2	12	
6	60 0500 072 5	ADJUSTING SCREW		12	
7	60 0502 640 4	HEXAGONAL NUT		12	
8	60 0502 640 5	SUPPORT		1	
9	60 0502 640 6	SUPPORT		5	
10	00 1135 960 0	SCREW	F-M 8X75	24	

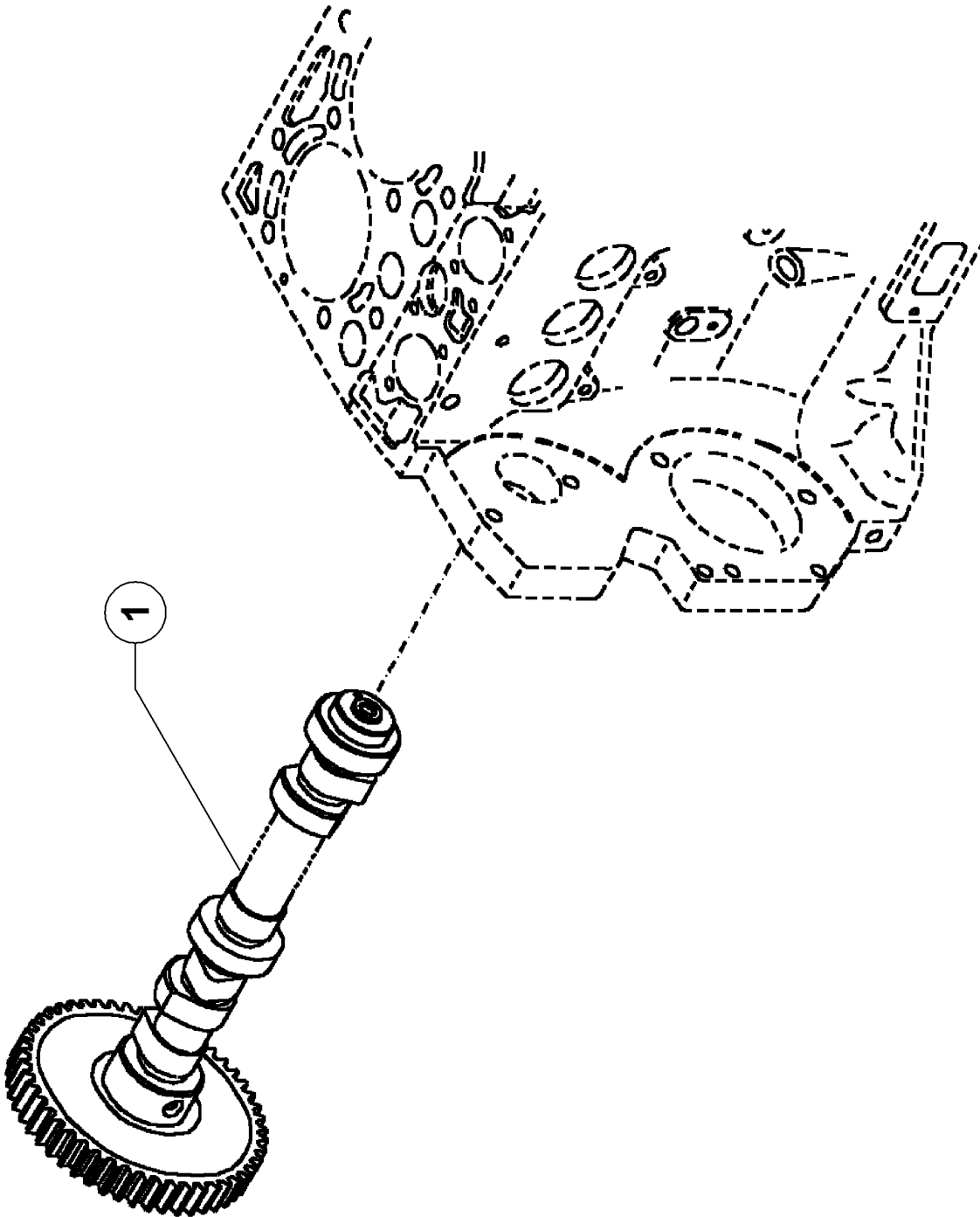
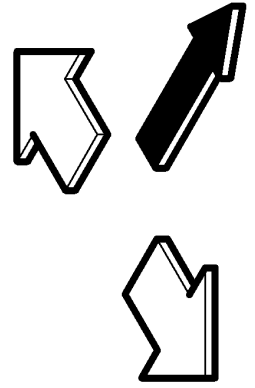



Suggest:

For more complete manuals. Please go to the home page.

<https://www.ebooklibonline.com>

If the above button click is invalid. Please download this document first, and then click the above link to download the complete manual.

Thank you so much for reading

180 CAMSHAFT, CAMSHAFT BEARING BUSHES

Pos.	Part No.	Description	Dimension	Quantity	Conditions
1	00 1144 428 0	CAMSHAFT		1	

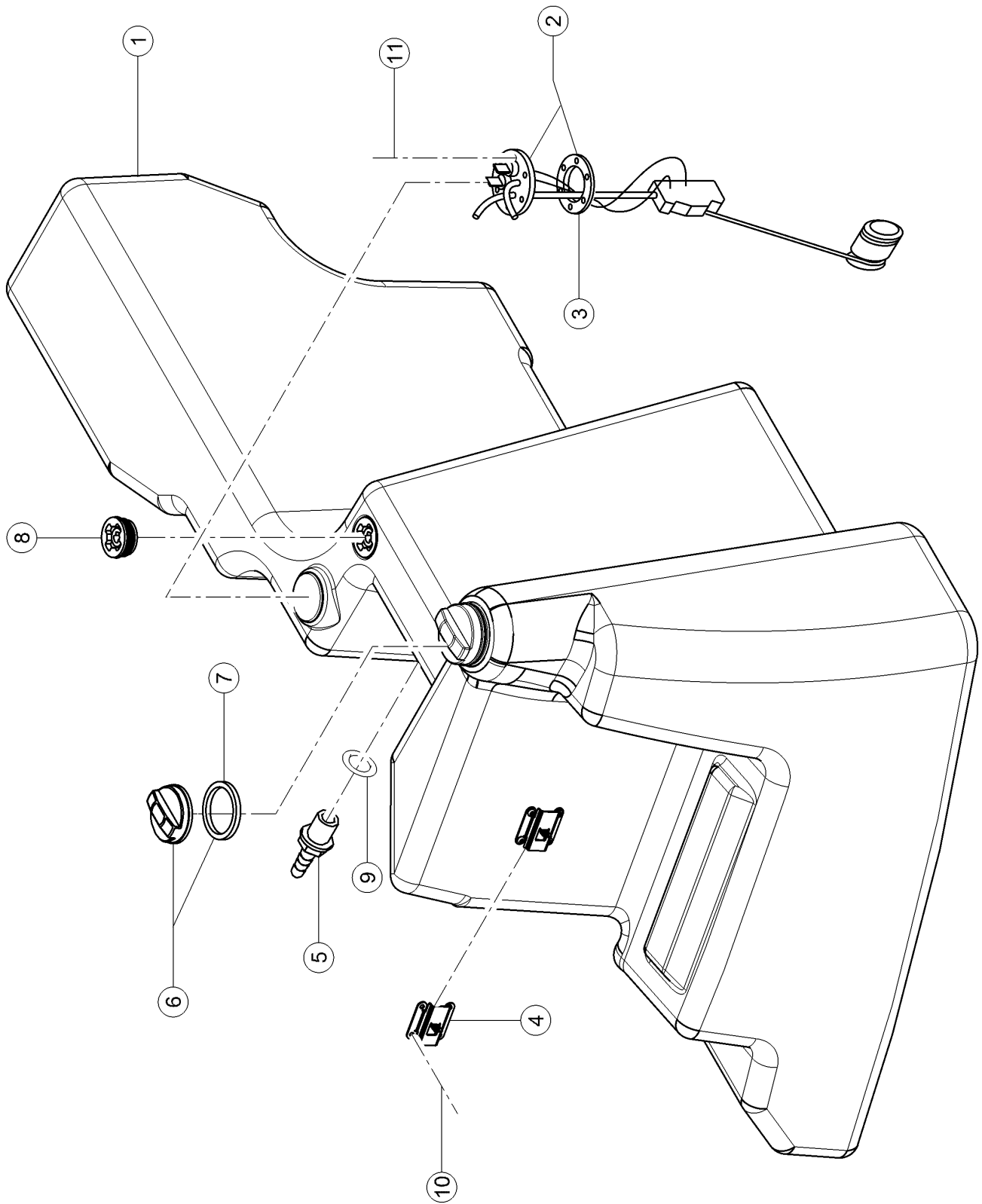

<https://www.ebooklibonline.com>

Hello dear friend!

Thank you very much for reading.

Enter the link into your browser.

The full manual is available for immediate download.

<https://www.ebooklibonline.com>