

**010 COMPLETE ENGINE**

<b>Pos.</b>	<b>Part No.</b>	<b>Description</b>	<b>Dimension</b>	<b>Quantity</b>	<b>Conditions</b>
1	<b>00 1106 734 0</b>	ENGINE		1	1)
1	<b>00 1106 735 0</b>	ENGINE		1	2)
1	<b>00 1106 736 0</b>	ENGINE		1	3)
1	<b>00 1106 737 0</b>	ENGINE		1	4)
<b>1)</b>	<b>Homologationtype</b>		+ 1904 120CH		
<b>2)</b>	<b>Homologationtype</b>		+ 1914 135CH		
<b>3)</b>	<b>Homologationtype</b>		+ 1924 145CH		
<b>4)</b>	<b>Homologationtype</b>		+ 1934 155CH		



**<https://www.ebooklibonline.com>**

Hello dear friend!

Thank you very much for reading.

Enter the link into your browser.

The full manual is available for immediate download.

**<https://www.ebooklibonline.com>**

**010 COMPLETE ENGINE**

<b>Pos.</b>	<b>Part No.</b>	<b>Description</b>	<b>Dimension</b>	<b>Quantity</b>	<b>Conditions</b>
1	<b>00 1150 449 0</b>	LONG BLOCK ENGINE		1	

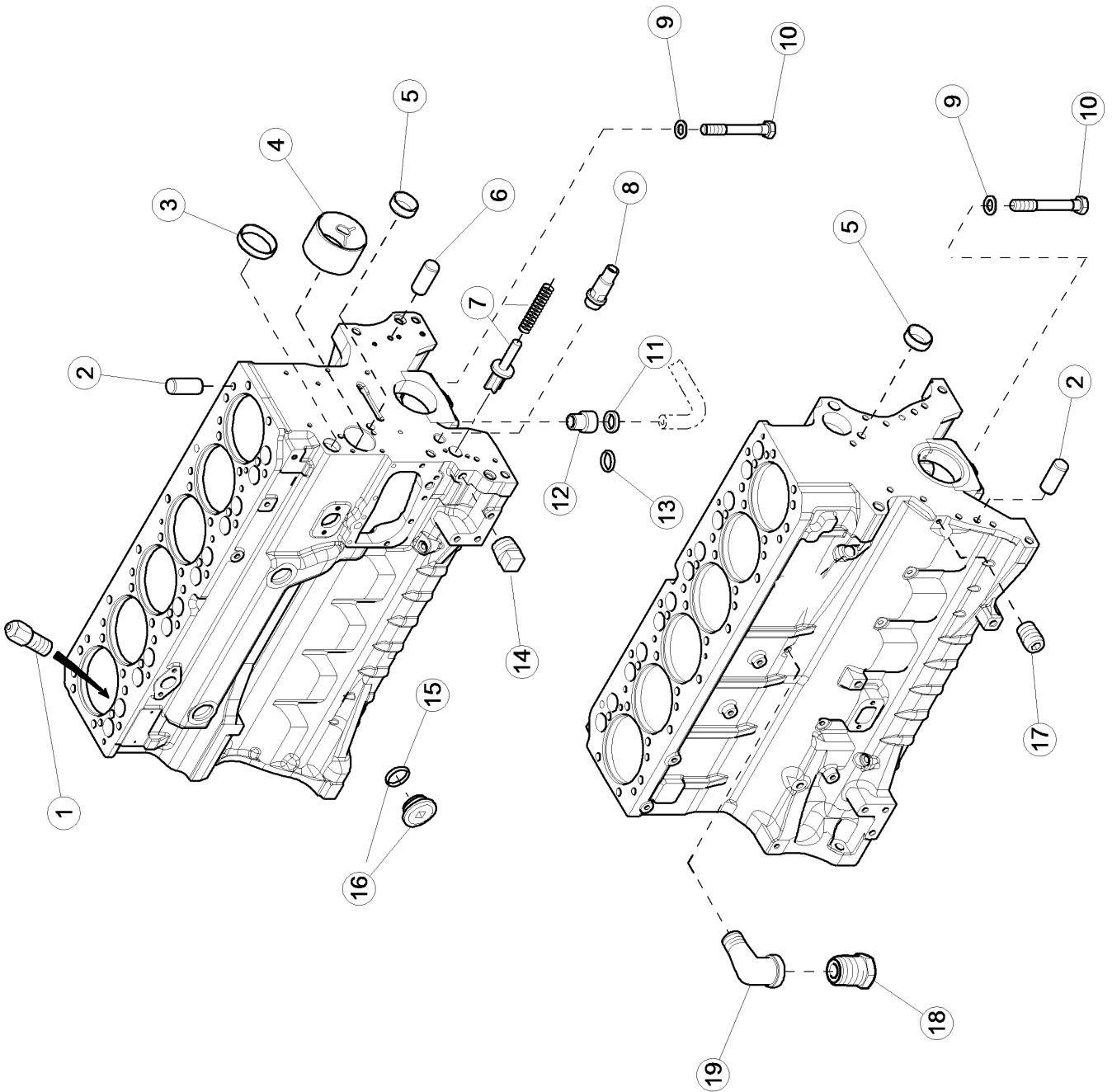

**100 CRANKCASE**

<b>Pos.</b>	<b>Part No.</b>	<b>Description</b>	<b>Dimension</b>	<b>Quantity</b>	<b>Conditions</b>
1	<b>60 0502 143 6</b>	SPRAY NOZZLE		6	
2	<b>60 0501 317 4</b>	CENTRING PIN		2	
3	<b>60 0502 143 9</b>	BLANKING COVER		1	
4	<b>60 0501 294 1</b>	BEARING		1	
5	<b>60 0501 319 8</b>	BLANKING COVER		2	
6	<b>60 0501 319 6</b>	CENTRING PIN		1	
7	<b>60 0501 402 9</b>	VALVE		1	
8	<b>60 0502 869 1</b>	VALVE		1	
9	<b>60 0502 143 7</b>	WASHER	13X22X2,5	14	
10	<b>60 0501 320 6</b>	SCREW		14	
11	<b>60 0501 334 1</b>	O-RING		1	
12	<b>60 0501 597 2</b>	BUSHING		1	
13	<b>60 0501 320 3</b>	O-RING		1	
14	<b>60 0501 597 1</b>	LOCK		1	
15	<b>60 0502 339 4</b>	O-RING		1	
16	<b>60 0502 905 2</b>	PLUG		1	
17	<b>60 0502 144 0</b>	LOCK		1	
18	<b>60 0502 665 3</b>	PLUG		1	
19	<b>00 1132 468 0</b>	ELBOW CONNECTOR		1	

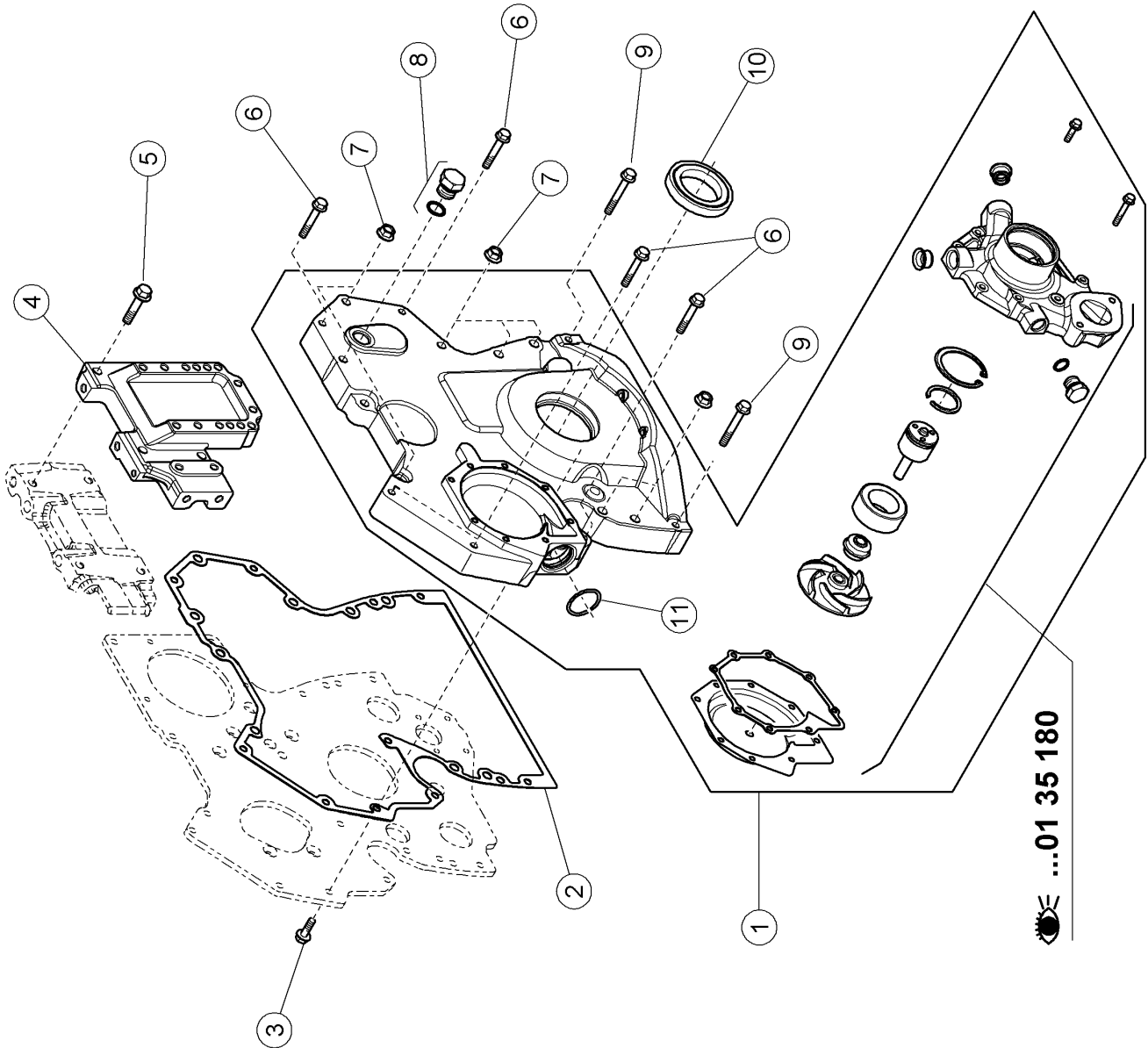

**120 TIMING CASE**

<b>Pos.</b>	<b>Part No.</b>	<b>Description</b>	<b>Dimension</b>	<b>Quantity</b>	<b>Conditions</b>
1	<b>00 1162 415 0</b>	CASING		1	
2	<b>00 1162 416 0</b>	FLAT SEAL		1	
3	<b>60 0502 145 6</b>	SCREW	M8X25	1	
4	<b>00 1132 471 0</b>	SUPPORT		4	
5	<b>60 0502 716 2</b>	SCREW	M10X45-LH	4	
6	<b>60 0502 593 6</b>	SCREW	M8X50	5	
7	<b>60 0502 144 9</b>	NUT		9	
8	<b>60 0502 160 3</b>	LOCK	M22X1,5	1	
9	<b>60 0502 145 0</b>	SCREW	M08X60	3	
10	<b>60 0503 024 7</b>	SEALING RING		1	
11	<b>60 0500 796 4</b>	O-RING	37,69 X 3,53 NBR 80	1	

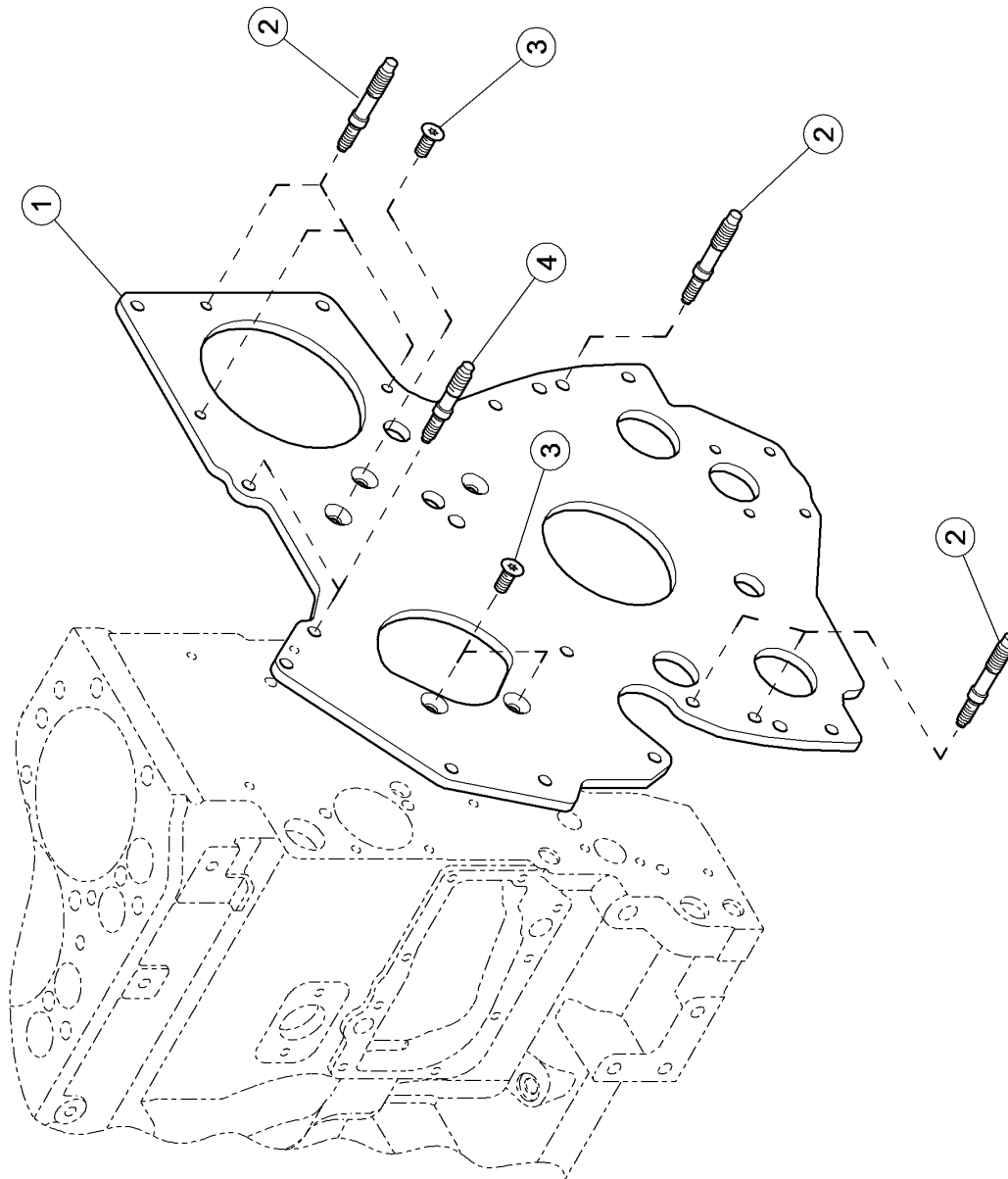

**120 TIMING CASE**

<b>Pos.</b>	<b>Part No.</b>	<b>Description</b>	<b>Dimension</b>	<b>Quantity</b>	<b>Conditions</b>
1	<b>00 1132 472 0</b>	PLATE		1	
2	<b>00 1132 473 0</b>	STUD BOLT		7	
3	<b>60 0502 339 7</b>	SCREW		5	
4	<b>60 0502 339 8</b>	STUD BOLT		2	

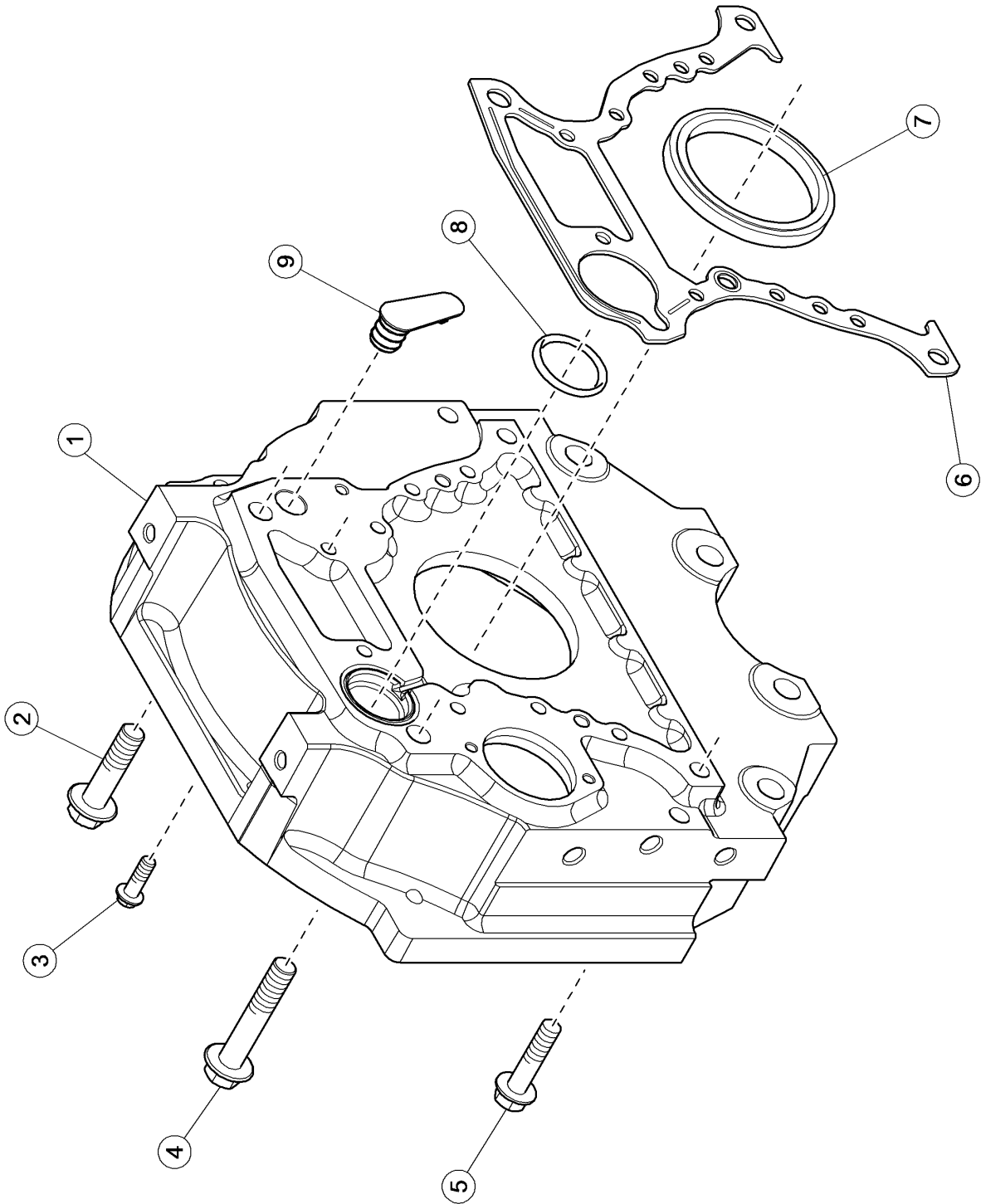

**140 FLYWHEEL HOUSING**

Pos.	Part No.	Description	Dimension	Quantity	Conditions
1	<b>77 0006 967 3</b>	CASING		1	
2	<b>60 0502 146 5</b>	SCREW		1	1)
3	<b>60 0502 625 8</b>	SCREW	12 X 1,75 -37 - M12X40	8	2)
4	<b>60 0502 146 6</b>	SCREW		1	3)
5	<b>60 0502 777 3</b>	SCREW	M16X60	2	
6	<b>77 0005 577 1</b>	GASKET		1	
7	<b>60 0501 279 0</b>	SHAFT SEAL	118X146X15	1	4)
8	<b>60 0501 604 9</b>	O-RING		1	
9	<b>60 0501 278 6</b>	BLANKING COVER		1	

<b>1)</b>	<b>Remarks</b>	M20X250-80
<b>2)</b>	<b>Remarks</b>	M12X175-38
<b>3)</b>	<b>Remarks</b>	M20X250-110
<b>4)</b>	<b>Remarks</b>	118X146X15

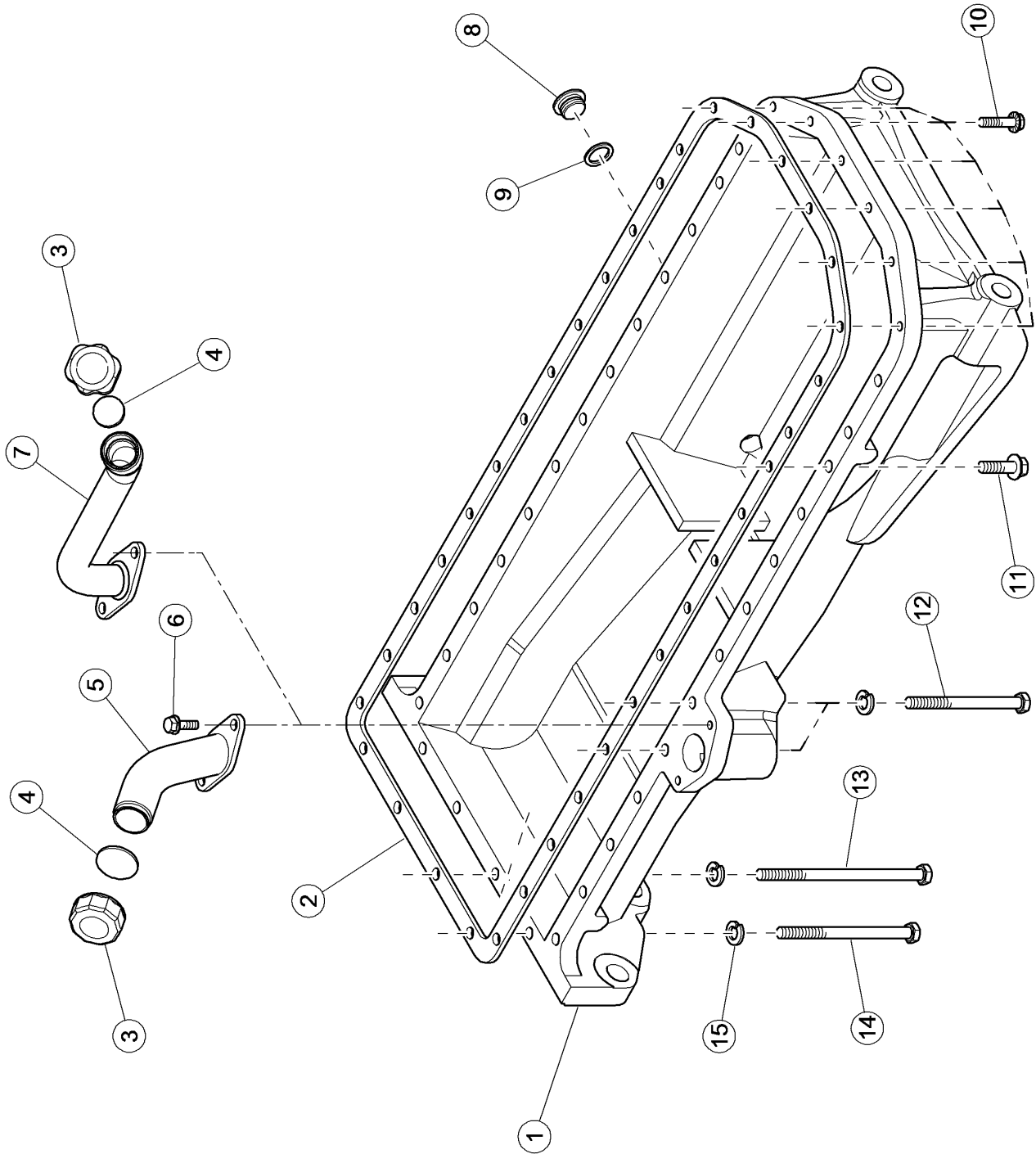

**160 OIL PAN**

Pos.	Part No.	Description	Dimension	Quantity	Conditions
1	<b>60 0502 666 5</b>	OIL SUMP		1	
2	<b>60 0502 666 6</b>	GASKET		1	
3	<b>00 1135 253 0</b>	PLUG		1	
4	<b>00 1135 255 0</b>	SEALING RING		1	
5	<b>00 1135 256 0</b>	TUBE		1	1)
6	<b>60 0502 145 6</b>	SCREW	M8X25	2	
7	<b>00 1117 366 1</b>	TUBE		1	2)
8	<b>00 1132 240 0</b>	PLUG		1	
9	<b>60 0501 211 0</b>	GASKET		1	
10	<b>77 0101 759 2</b>	SCREW	M08X35 VERBUS RIPP	6	
11	<b>77 0001 434 0</b>	SCREW	M10X35 - VERBUS RIPP	24	
12	<b>60 0502 147 1</b>	SCREW		2	
13	<b>77 0102 451 6</b>	SCREW		2	
14	<b>77 0310 108 5</b>	HEXAGON HEAD BOLT	M10X140-32	2	
15	<b>77 0305 501 3</b>	WASHER	10	6	

**1) Equipment**

TD\_201\_0000

Without pre-equipment for front loader

**2) Equipment**

TD\_201\_0001

PRE EQUIPEMENT CHARGEUR AV.

TD\_201\_0002

Pre-equipement for PROPILOT front loader

TD\_201\_0003

FLEXPILOT

Front loader pre-equipment (requires 213 0001 and loader jib)

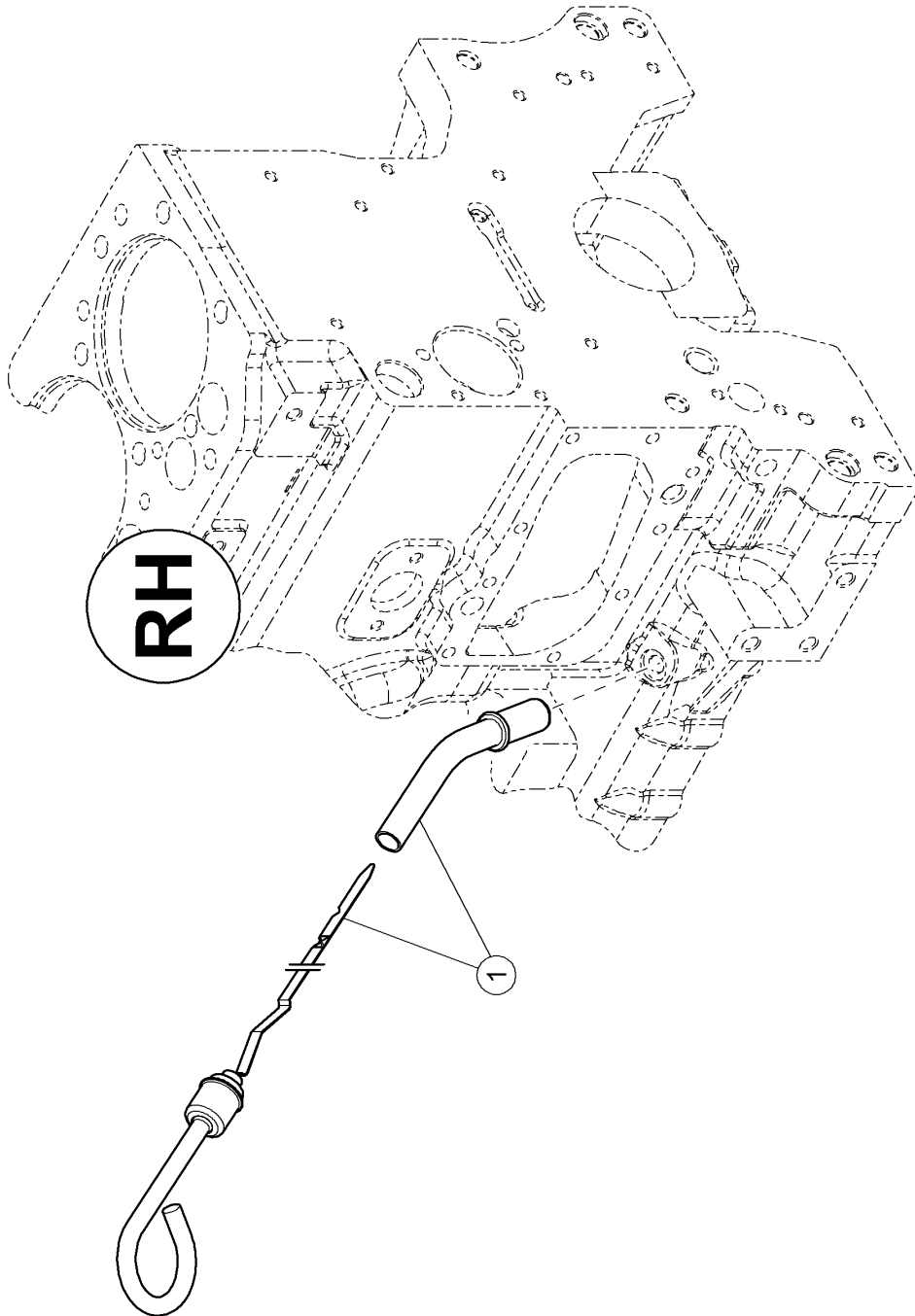

**160 OIL PAN**

<b>Pos.</b>	<b>Part No.</b>	<b>Description</b>	<b>Dimension</b>	<b>Quantity</b>	<b>Conditions</b>
1	<b>00 1147 501 0</b>	GAUGE		1	

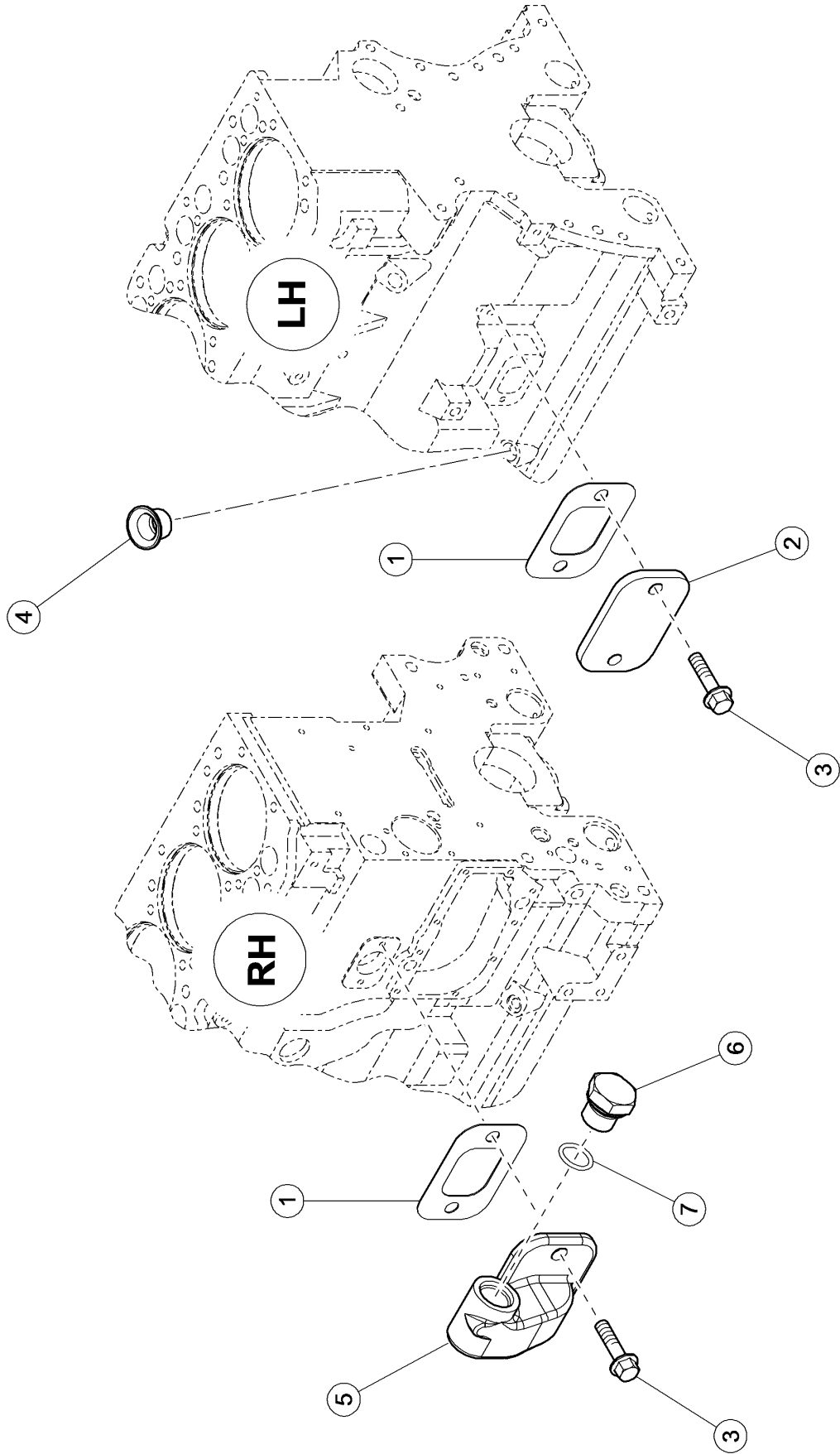

**180 PLUGS**

<b>Pos.</b>	<b>Part No.</b>	<b>Description</b>	<b>Dimension</b>	<b>Quantity</b>	<b>Conditions</b>
1	<b>60 0502 470 4</b>	GASKET		2	
2	<b>60 0502 470 2</b>	PLATE		1	
3	<b>60 0502 149 8</b>	SCREW	M8X20	4	
4	<b>60 0502 662 4</b>	PLUG		1	
5	<b>00 1135 000 0</b>	MANIFOLD		1	
6	<b>60 0502 160 7</b>	PLUG	F-M18X1,5 ERS.D.7700054	1	
7	<b>60 0502 160 8</b>	O-RING	15,3X2,2-N	1	

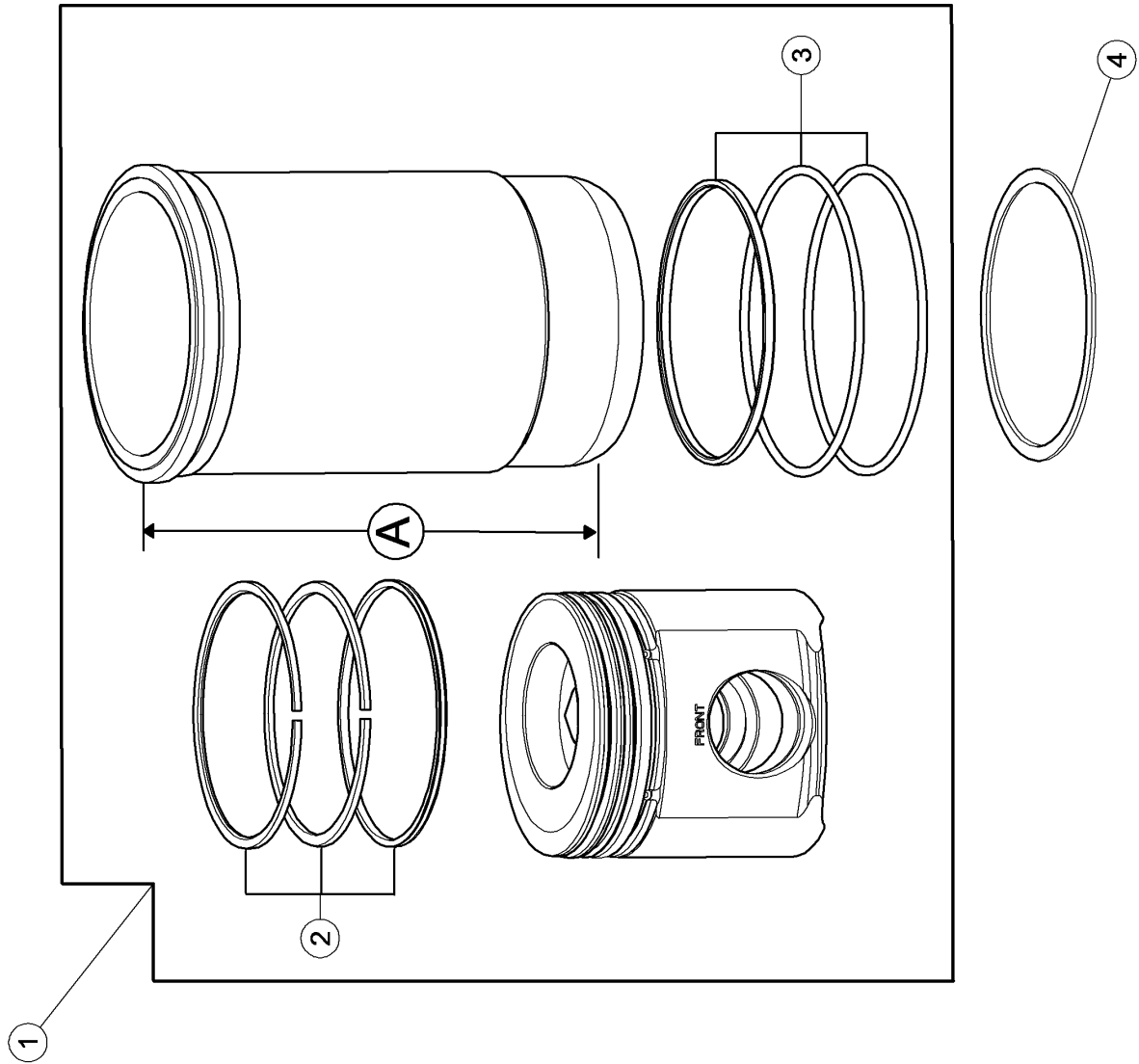

**100 CYLINDER LINER, PISTON**

<b>Pos.</b>	<b>Part No.</b>	<b>Description</b>	<b>Dimension</b>	<b>Quantity</b>	<b>Conditions</b>
1	<b>00 1132 478 0</b>	PISTON-LINER		6	
2	<b>00 1132 480 0</b>	SET OF PISTON RINGS		6	
3	<b>60 0501 280 9</b>	SEALING RING SET		6	
4	<b>60 0501 281 5</b>	ADJUSTING DISC		6	1)
4	<b>60 0501 281 6</b>	ADJUSTING DISC		6	2)
<b>1)</b>	<b>Remarks</b>		[SR] EP.0.05MM		
<b>2)</b>	<b>Remarks</b>		[SR] EP.0.10MM		

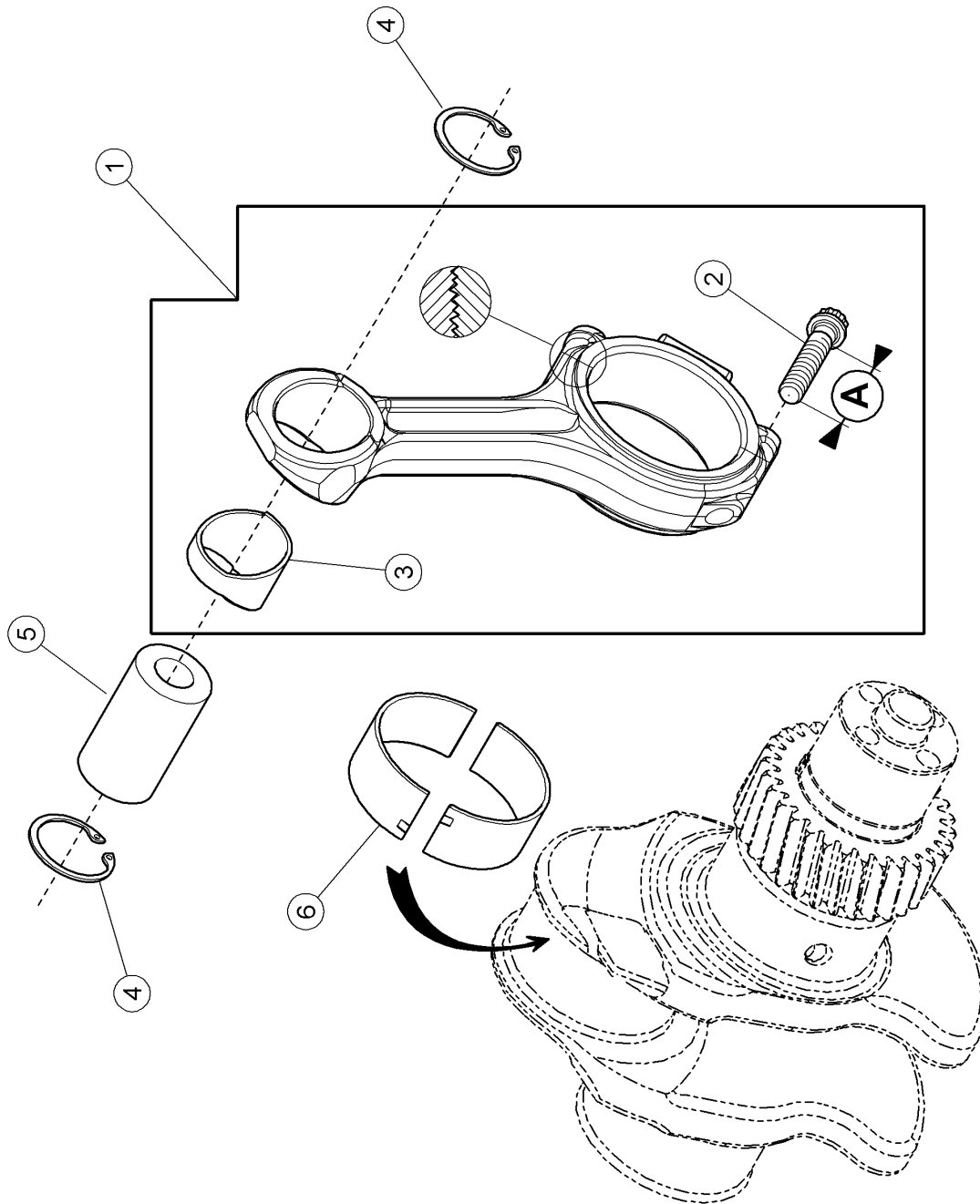

**120 CONNECTING ROD, CONNECTING ROD BEARINGS**

<b>Pos.</b>	<b>Part No.</b>	<b>Description</b>	<b>Dimension</b>	<b>Quantity</b>	<b>Conditions</b>
1	<b>60 0502 453 6</b>	CONNECTING ROD		6	
2	<b>60 0502 453 7</b>	SCREW	12 PTS M12 X 1,25 - 61	12	
3	<b>60 0502 147 6</b>	RING		6	
4	<b>60 0501 281 4</b>	INNER CIRCLIP		12	
5	<b>00 1132 482 0</b>	AXLE		6	
6	<b>60 0502 147 8</b>	BEARING		6	
6	<b>60 0502 147 9</b>	BEARING		6	1)
<b>1)</b>	<b>Remarks</b>		-0.254MM		

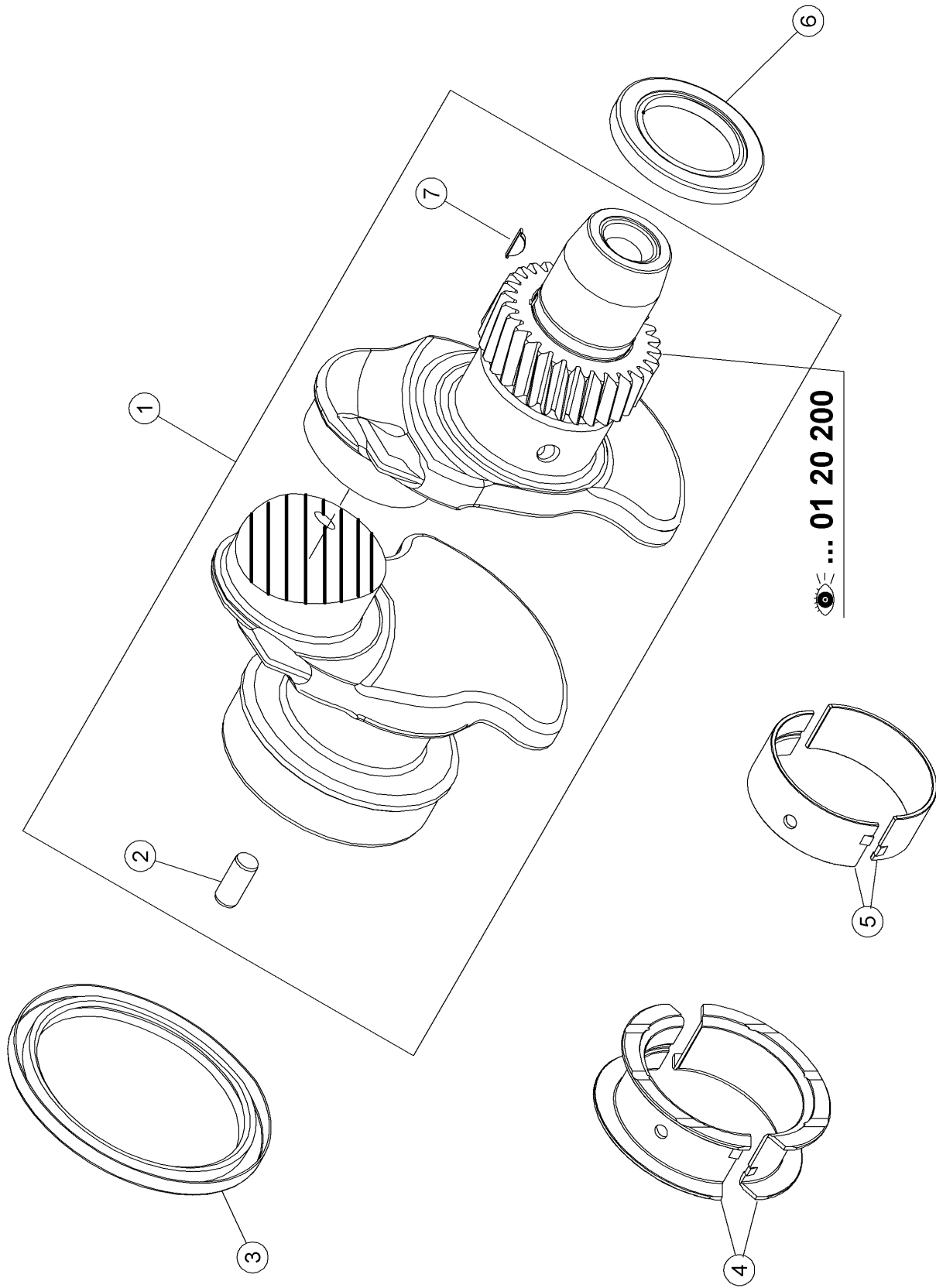

**140 CRANKSHAFT**

<b>Pos.</b>	<b>Part No.</b>	<b>Description</b>	<b>Dimension</b>	<b>Quantity</b>	<b>Conditions</b>
1	<b>60 0502 869 6</b>	CRANKSHAFT		1	
2	<b>60 0501 317 4</b>	CENTRING PIN		1	
3	<b>60 0501 279 0</b>	SHAFT SEAL	118X146X15	1	
4	<b>60 0502 148 2</b>	BEARING		1	1)
4	<b>60 0502 148 1</b>	BEARING		1	
5	<b>60 0502 148 4</b>	BEARING		6	1)
5	<b>60 0502 148 3</b>	BEARING		6	
6	<b>60 0503 024 7</b>	SEALING RING		1	
7	<b>60 0502 869 7</b>	KEY		1	
<b>1)</b>	<b>Remarks</b>				-0.254MM

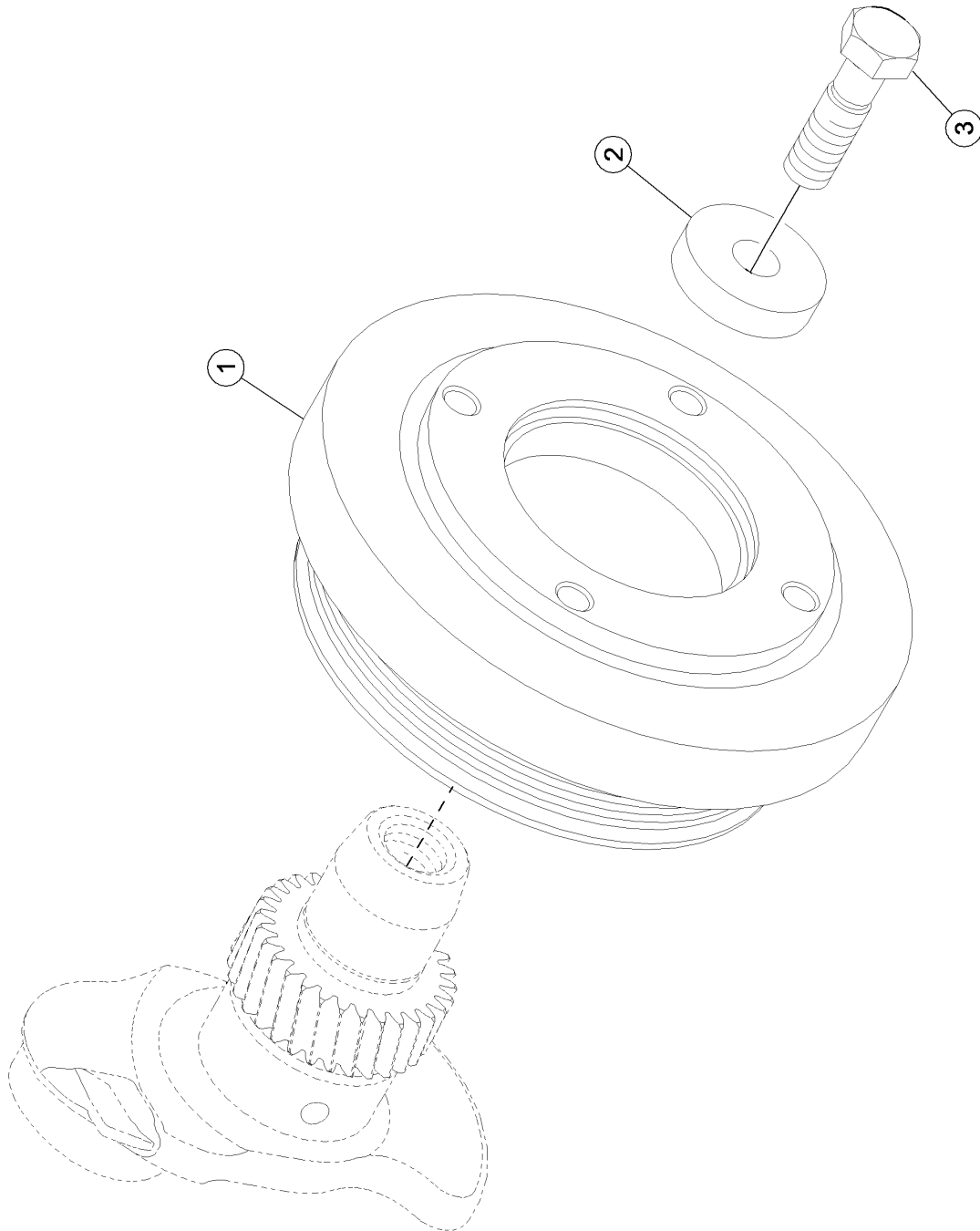

**160 CRANKSHAFT PULLEY WHEEL**

<b>Pos.</b>	<b>Part No.</b>	<b>Description</b>	<b>Dimension</b>	<b>Quantity</b>	<b>Conditions</b>
1	<b>77 0006 623 2</b>	ANTI-VIBRATION WHEEL		1	
2	<b>60 0503 045 1</b>	SPACER		1	
3	<b>60 0502 866 8</b>	SCREW	M20X70	1	

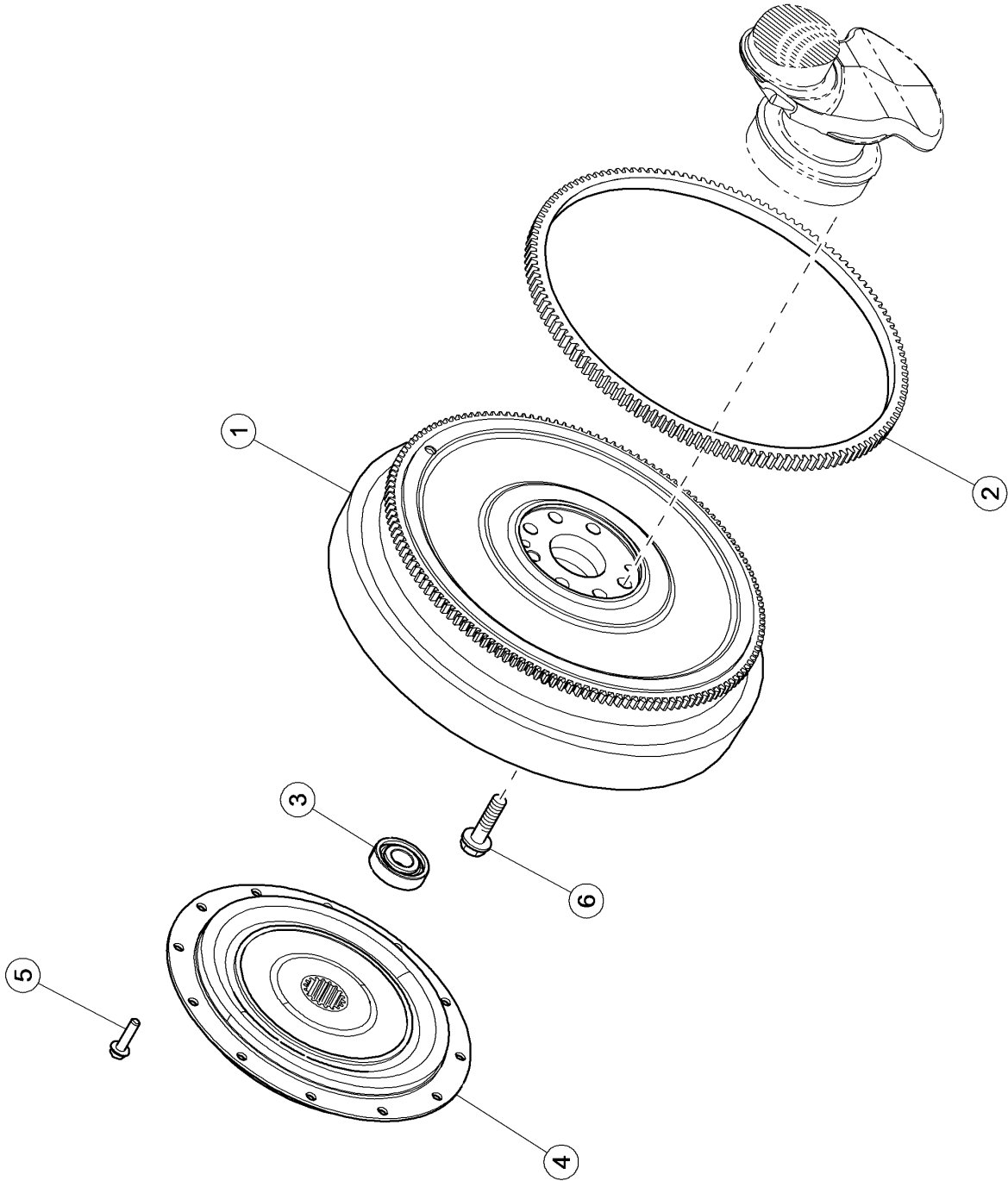

**220 FLYWHEEL**

<b>Pos.</b>	<b>Part No.</b>	<b>Description</b>	<b>Dimension</b>	<b>Quantity</b>	<b>Conditions</b>
1	<b>77 0007 132 9</b>	FLYWHEEL		1	
2	<b>77 0004 728 5</b>	TOOTHED RIM		1	
3	<b>77 0103 068 6</b>	BEARING-1 BALL	6305-2RS	1	
4	<b>00 1111 394 0</b>	HUB		1	
5	<b>77 0005 997 8</b>	HEXAGON HEAD BOLT	M10X40	8	1)
6	<b>60 0502 625 8</b>	SCREW	12 X 1,75 -37 - M12X40	6	2)
<b>1)</b>	<b>Remarks</b>		M10X150-40		
<b>2)</b>	<b>Remarks</b>		M12X175-38		

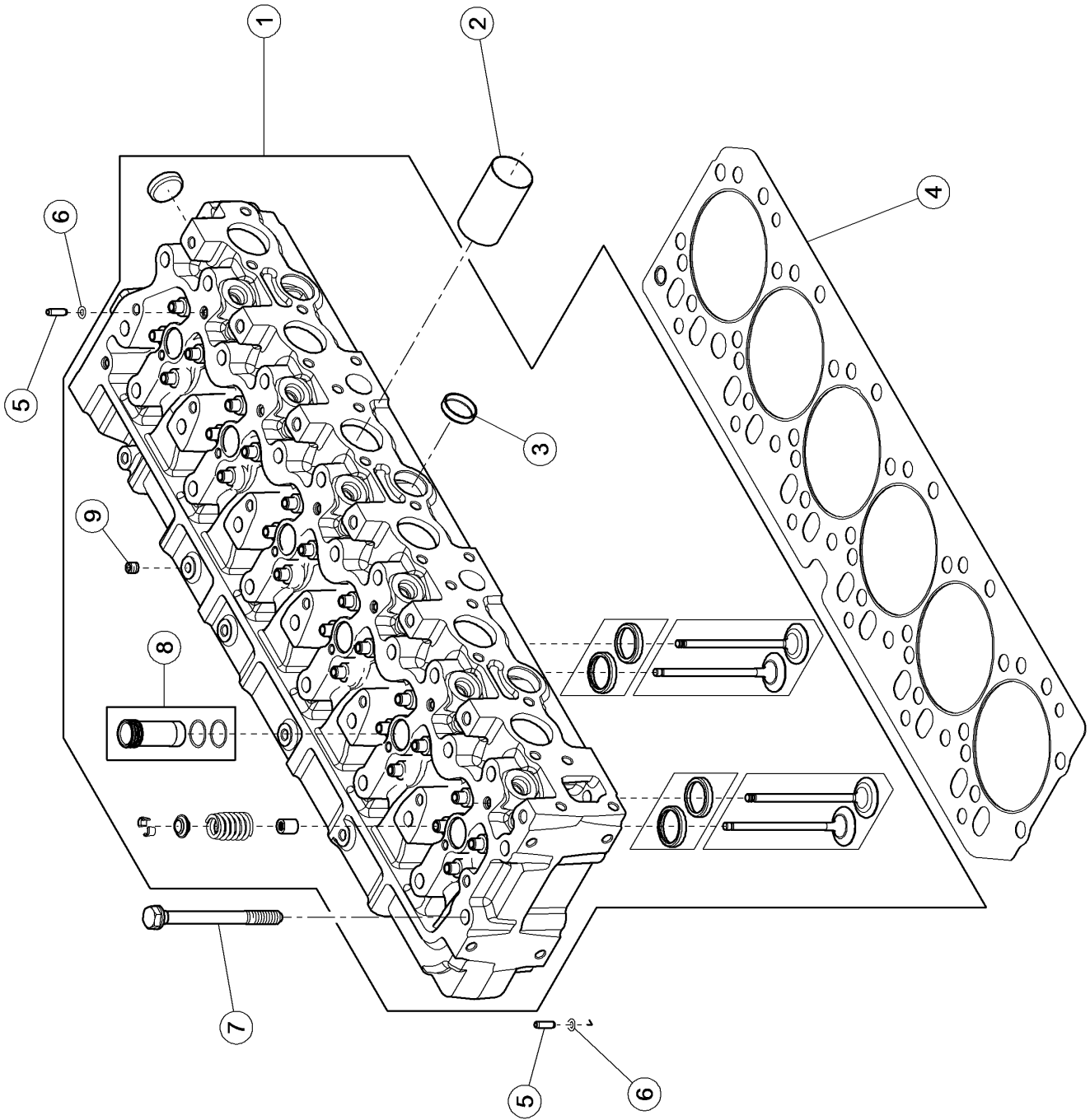

**100 CYLINDER HEAD**

<b>Pos.</b>	<b>Part No.</b>	<b>Description</b>	<b>Dimension</b>	<b>Quantity</b>	<b>Conditions</b>
1	<b>00 1164 535 0</b>	CYLINDER HEAD		1	
2	<b>00 1132 502 0</b>	LINER		6	
3	<b>60 0501 288 3</b>	LOCK		4	
4	<b>00 1146 047 1</b>	CYLINDER HEAD GASKET	94*32*3	1	
5	<b>00 1132 503 0</b>	PIN		2	
6	<b>00 1145 929 0</b>	O-RING		7	
7	<b>00 1145 541 0</b>	SCREW	1/2-13UNC-2AX5 1/3	26	
8	<b>00 1142 367 0</b>	LINER		6	
9	<b>60 0502 144 0</b>	LOCK		1	

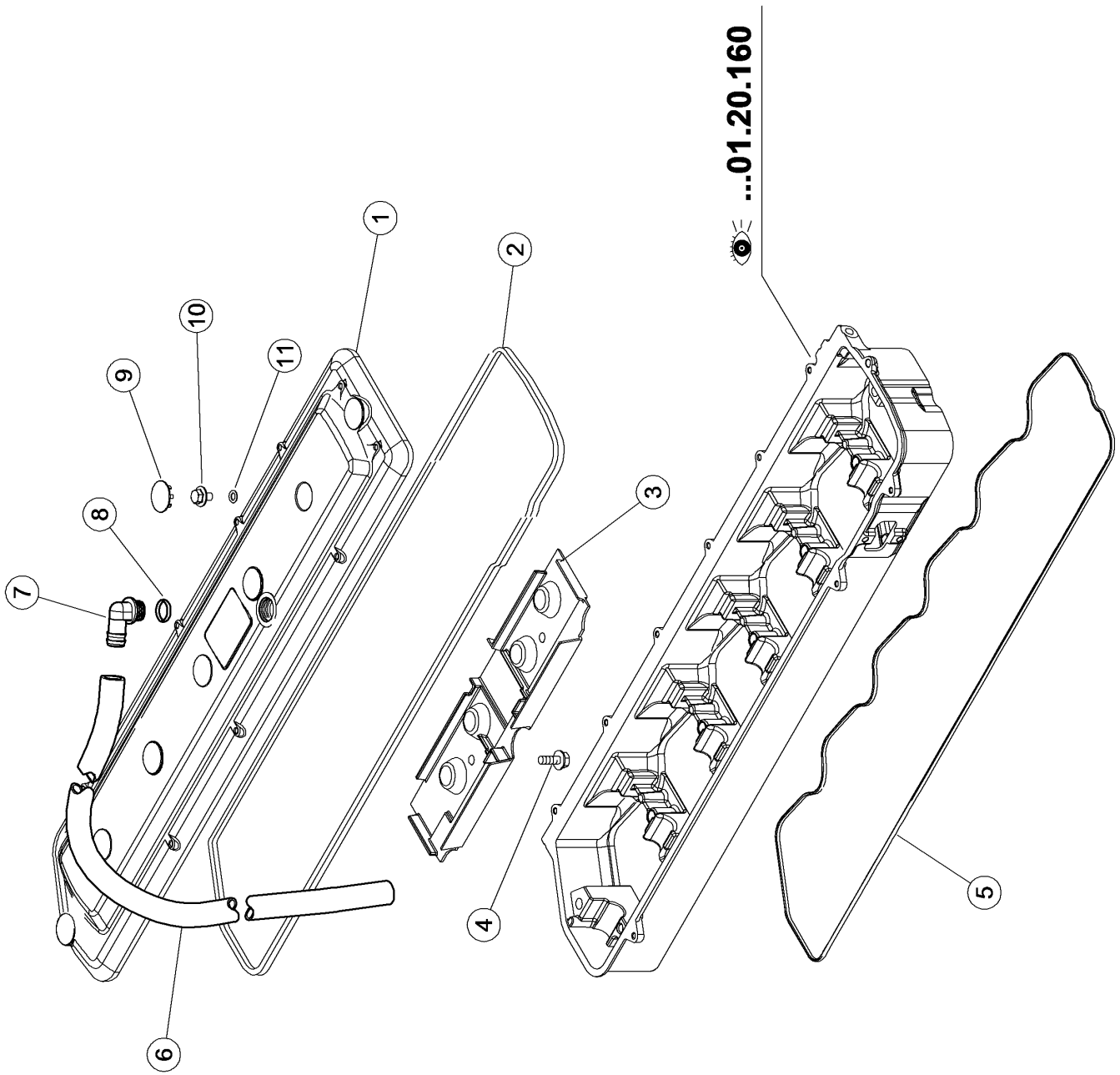

**120 CYLINDER HEAD COVER**

<b>Pos.</b>	<b>Part No.</b>	<b>Description</b>	<b>Dimension</b>	<b>Quantity</b>	<b>Conditions</b>
1	<b>00 1133 936 0</b>	ROCKER COVER		1	
2	<b>00 1137 973 0</b>	SEALING RING		1	
3	<b>00 1132 508 0</b>	DEFLECTOR		1	
4	<b>60 0502 144 8</b>	SCREW	M6X16	2	
5	<b>00 1131 838 0</b>	SEALING RING		1	
6	<b>60 0503 048 0</b>	HOSE		1	
7	<b>00 1133 935 0</b>	ELBOW		1	
8	<b>60 0502 160 4</b>	O-RING	19X2.4	1	
9	<b>60 0502 134 4</b>	PLUG		7	
10	<b>60 0502 594 5</b>	SCREW		7	
11	<b>60 0502 134 7</b>	O-RING	W.ERS. D. 0219 147.0	7	

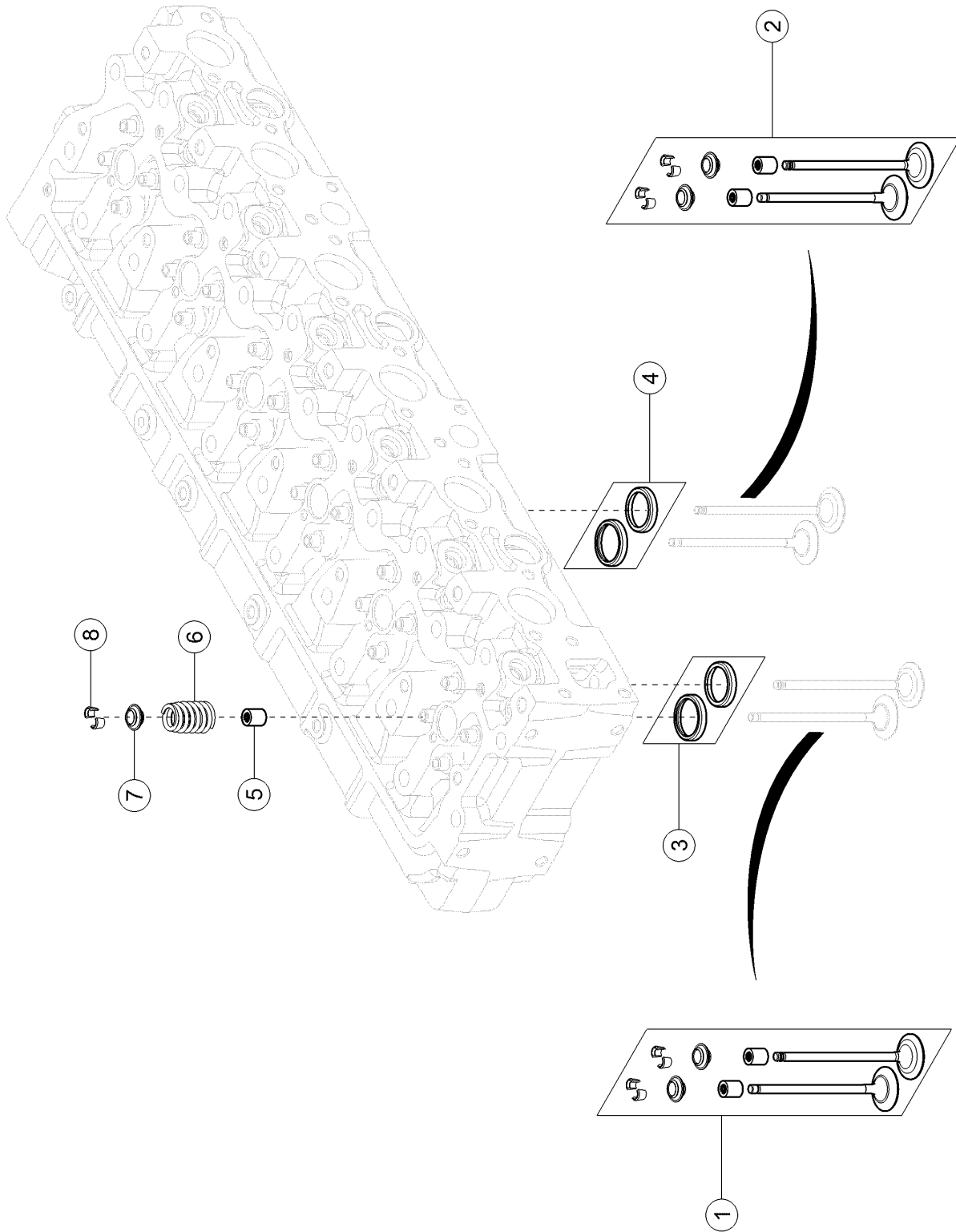

**140 VALVES**

<b>Pos.</b>	<b>Part No.</b>	<b>Description</b>	<b>Dimension</b>	<b>Quantity</b>	<b>Conditions</b>
1	<b>00 1148 701 0</b>	VALVE		6	1)
2	<b>00 1148 700 0</b>	VALVE		6	2)
3	<b>00 1132 513 0</b>	VALVE SEAT		6	1)
4	<b>00 1132 514 0</b>	VALVE SEAT		6	2)
5	<b>00 1139 912 0</b>	SEALING RING		24	
6	<b>00 1132 517 0</b>	SPRING		24	
7	<b>00 1132 518 0</b>	WASHER		24	
8	<b>00 1132 520 0</b>	HALF-CONE		24	
<b>1)</b>	<b>Remarks</b>		Echapt		
<b>2)</b>	<b>Remarks</b>		Adm.		



**Suggest:**

**For more complete manuals. Please go to the home page.**

**<https://www.ebooklibonline.com>**

**If the above button click is invalid. Please download this document first, and then click the above link to download the complete manual.**

**Thank you so much for reading**

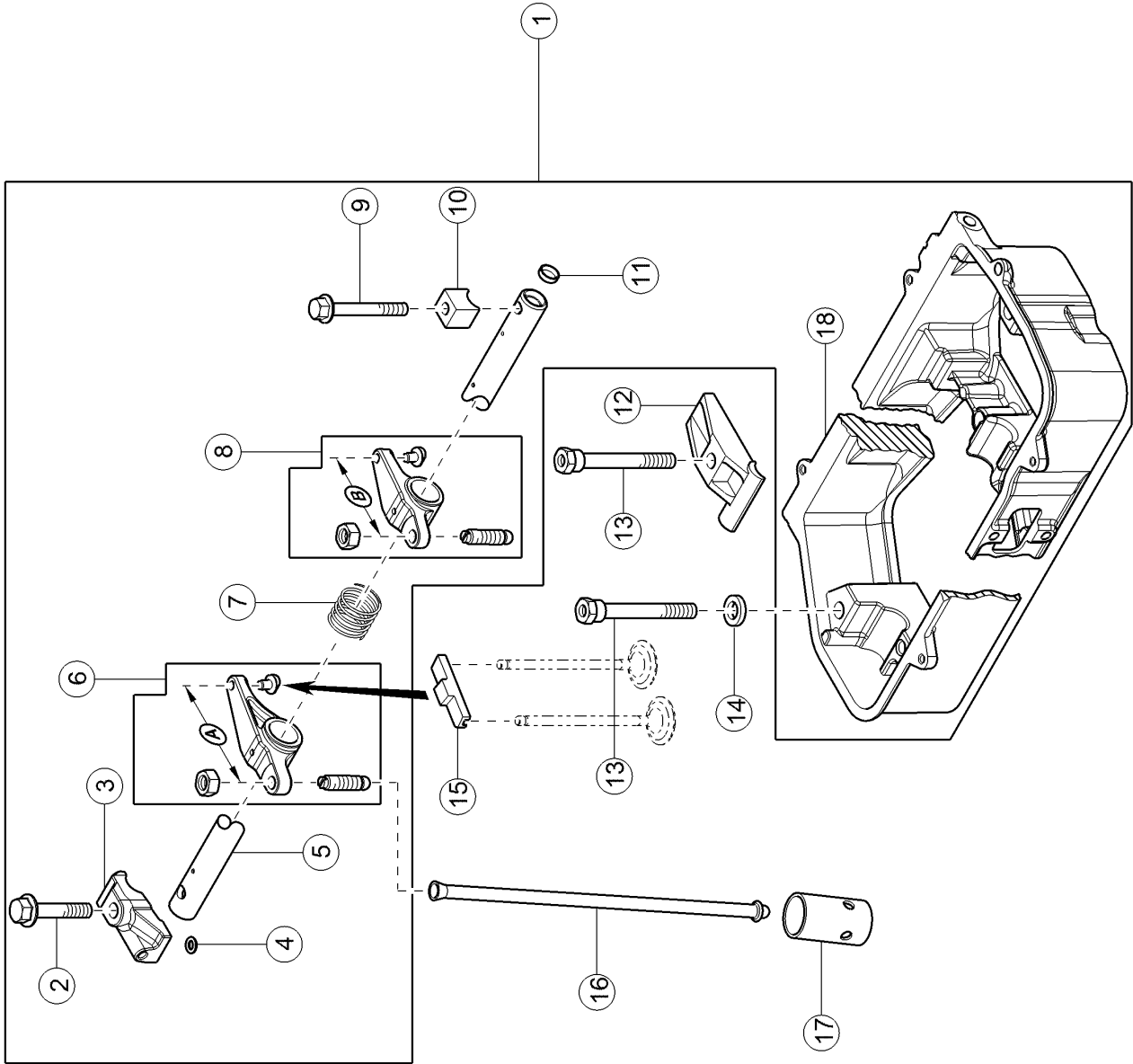

**160 ROCKER ARM**

<b>Pos.</b>	<b>Part No.</b>	<b>Description</b>	<b>Dimension</b>	<b>Quantity</b>	<b>Conditions</b>
1	<b>00 1137 651 0</b>	HOUSING		1	
2	<b>60 0502 152 1</b>	SCREW		1	
3	<b>00 1132 524 0</b>	FLANGE		1	
4	<b>00 1145 929 0</b>	O-RING		1	
5	<b>00 1132 526 0</b>	DRIVE SHAFT		1	
6	<b>00 1132 528 0</b>	ROCKER ARM		6	
7	<b>00 1132 530 0</b>	SPRING		6	
8	<b>00 1132 531 0</b>	ROCKER ARM		6	
9	<b>60 0502 593 6</b>	SCREW	M8X50	1	
10	<b>00 1132 533 0</b>	FLANGE		1	
11	<b>00 1132 534 0</b>	PLUG		2	
12	<b>00 1132 535 0</b>	FLANGE		5	
13	<b>00 1132 536 0</b>	SCREW		7	
14	<b>60 0501 278 2</b>	WASHER		2	
15	<b>00 1132 537 0</b>	TIPPER		12	
16	<b>00 1132 538 0</b>	ROD		12	
17	<b>60 0502 150 7</b>	PUSHROD		12	
18	<b>00 1170 842 0</b>	CASING		1	

**<https://www.ebooklibonline.com>**

Hello dear friend!

Thank you very much for reading.

Enter the link into your browser.

The full manual is available for immediate download.

**<https://www.ebooklibonline.com>**