

010 COMPLETE ENGINE 1)

Pos.	Part No.	Description	Dimension	Quantity	Conditions
1	00 1164 341 0	ENGINE		1	
1)	machine type	A75	+ ARION 550-510 St4 CMATIC		

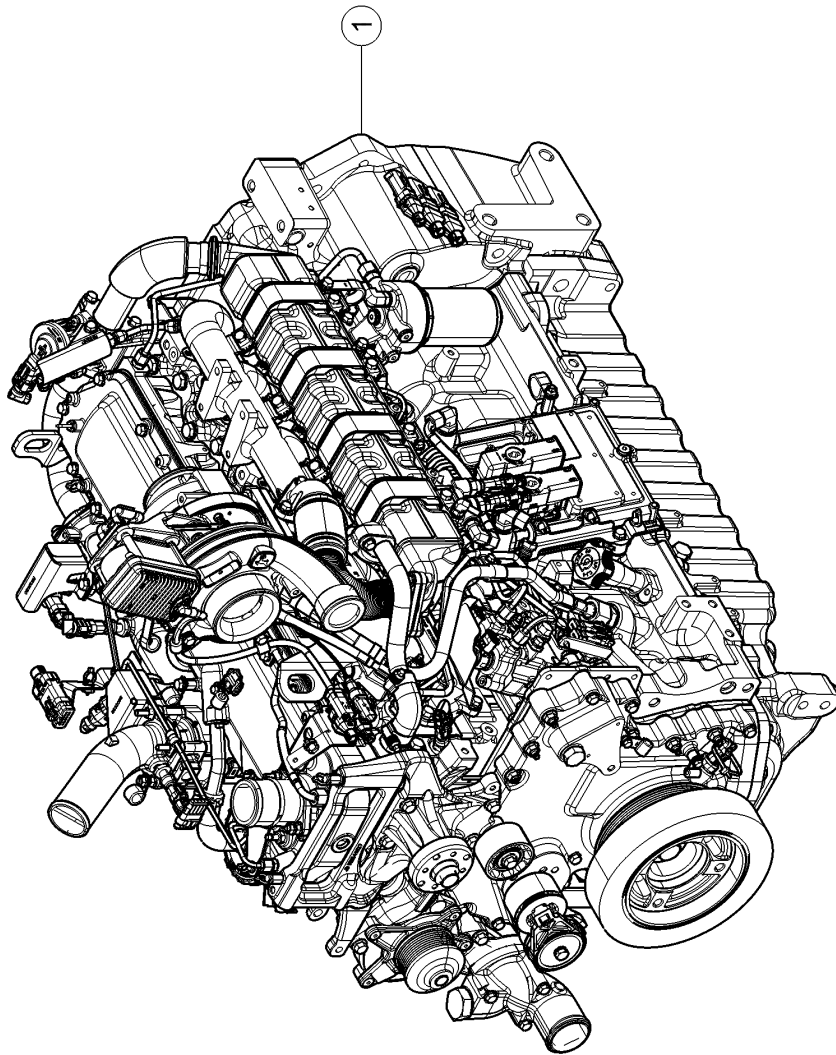

<https://www.ebooklibonline.com>

Hello dear friend!

Thank you very much for reading.

Enter the link into your browser.

The full manual is available for immediate download.

<https://www.ebooklibonline.com>

010 COMPLETE ENGINE 1)

Pos.	Part No.	Description	Dimension	Quantity	Conditions
1	00 1164 343 0	ENGINE		1	
1)	machine type	A77	+ ARION 660-610 St4 CMATIC		

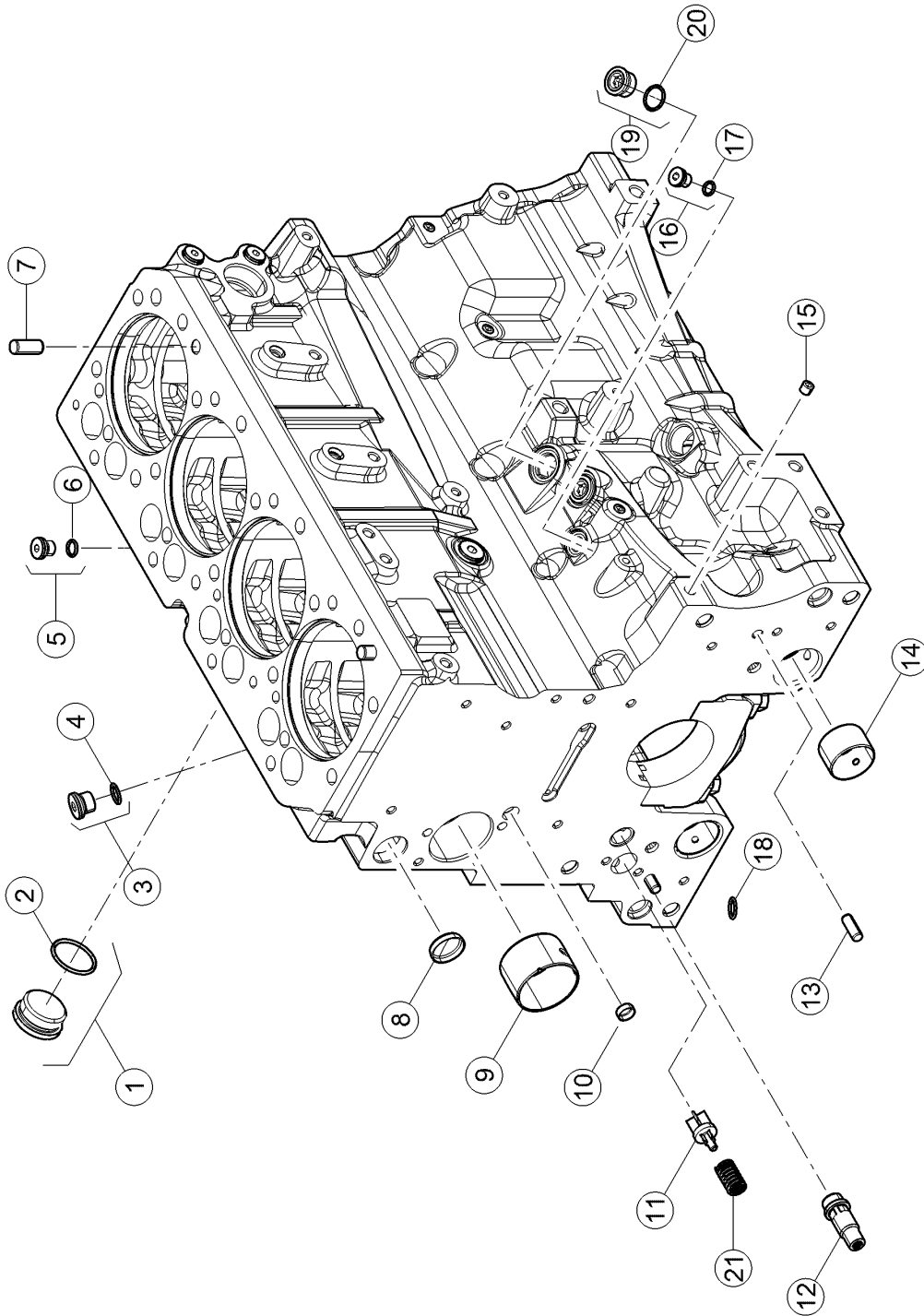

100 CRANKCASE 1)

Pos.	Part No.	Description	Dimension	Quantity	Conditions
1	60 0502 905 2	PLUG		2	
2	60 0501 938 3	O-RING		2	
3	00 1145 876 0	PLUG		2	
4	60 0502 160 8	O-RING	15,3X2,2-N	2	
5	00 1145 880 0	PLUG		4	
6	60 0502 164 1	O-RING		4	
7	60 0501 317 4	CENTRING PIN		4	
8	60 0502 143 9	BLANKING COVER		1	
9	60 0501 294 1	BEARING		2	
10	60 0501 319 8	BLANKING COVER		2	
11	00 1145 875 0	VALVE		1	
12	60 0502 869 1	VALVE		1	
13	60 0501 319 6	CENTRING PIN		2	
14	60 0502 593 1	RING		2	
15	00 1141 206 0	PLUG		5	
16	00 1161 401 0	PLUG		1	
17	60 0502 156 7	O-RING	9,3X2,2	1	
18	60 0501 320 3	O-RING		1	
19	00 1145 914 0	BLANKING COVER		2	
20	60 0502 160 4	O-RING	19X2,4	2	
21	60 0501 320 1	SPRING		1	
<hr/>					
1)	machine type	A75	+ ARION 550-510 St4 CMATIC		
<hr/>					

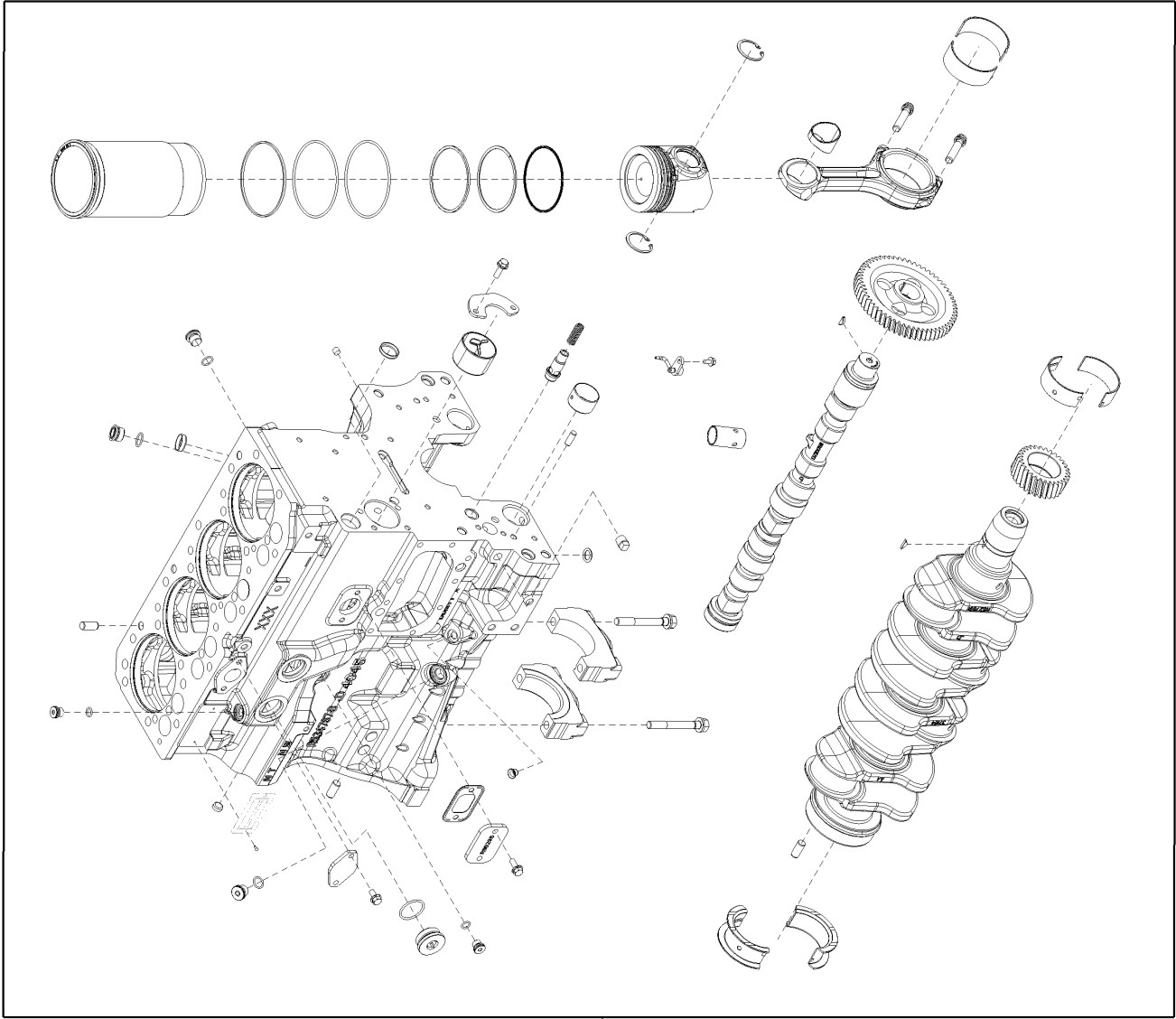

1

100 CRANKCASE 1)

Pos.	Part No.	Description	Dimension	Quantity	Conditions
1	00 1171 784 0	SHORT BLOCK		1	
1)	machine type	A75	+ ARION 550-510 St4 CMATIC		

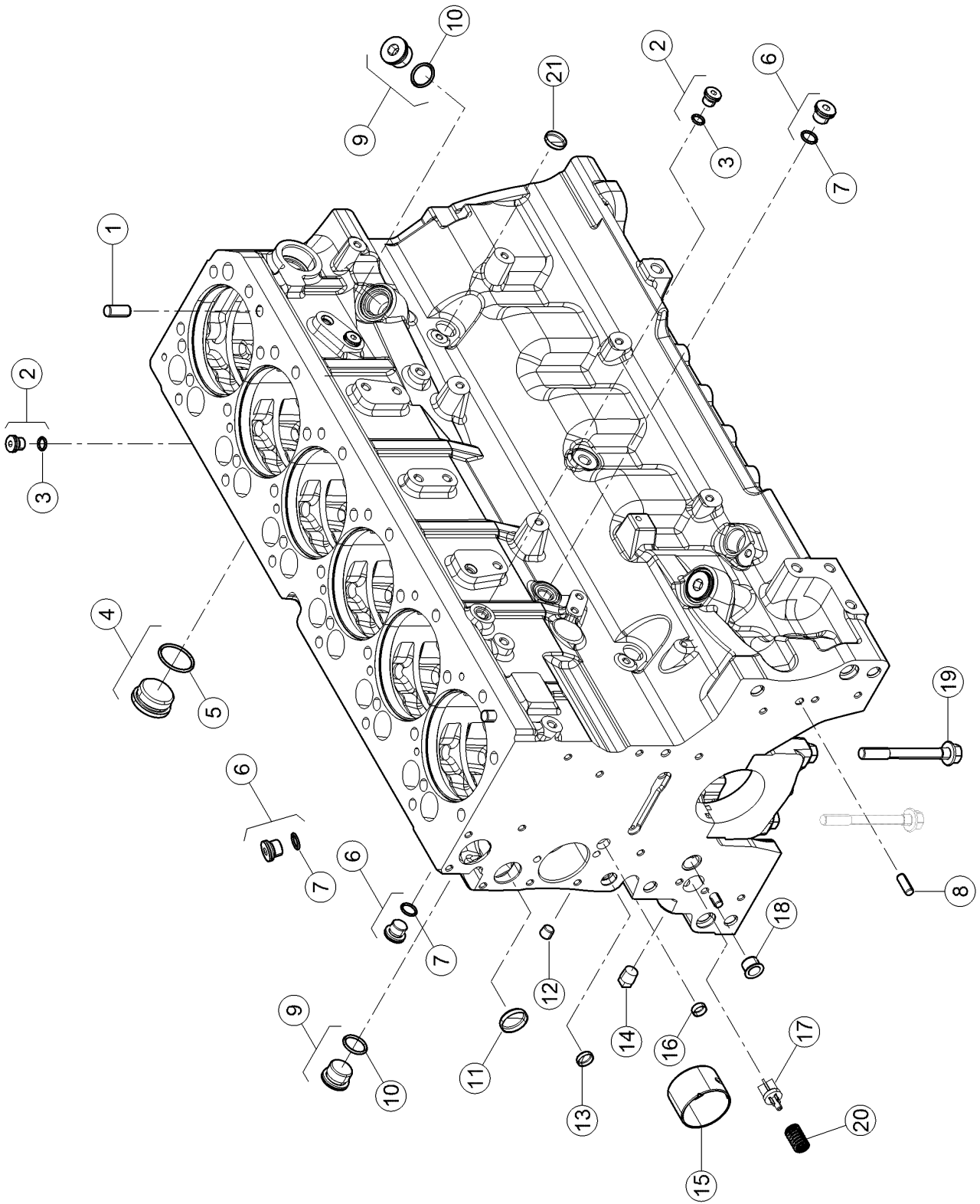

100 CRANKCASE 1)

Pos.	Part No.	Description	Dimension	Quantity	Conditions
1	60 0501 317 4	CENTRING PIN		4	
2	00 1145 880 0	PLUG		5	
3	60 0502 164 1	O-RING		5	
4	60 0502 905 2	PLUG		1	
5	60 0501 938 3	O-RING		1	
6	00 1145 876 0	PLUG		3	
7	60 0502 160 8	O-RING	15,3X2,2-N	3	
8	60 0501 319 6	CENTRING PIN		2	
9	00 1146 439 0	PLUG		4	
10	00 1146 440 0	O-RING		4	
11	60 0502 143 9	BLANKING COVER		1	
12	60 0501 320 8	LOCK		1	
13	00 1146 442 0	PLUG		1	
14	60 0501 597 1	LOCK		1	
15	60 0501 294 1	BEARING		1	
16	60 0501 319 8	BLANKING COVER		2	
17	00 1145 875 0	VALVE		1	
18	00 1165 185 0	SMOOTH RING		1	
19	00 1146 443 0	SCREW		14	
20	60 0501 320 1	SPRING		1	
21	00 1166 832 0	BLANKING COVER		1	
<hr/>					
1)	machine type	A77	+ ARION 660-610 St4 CMATIC		
<hr/>					

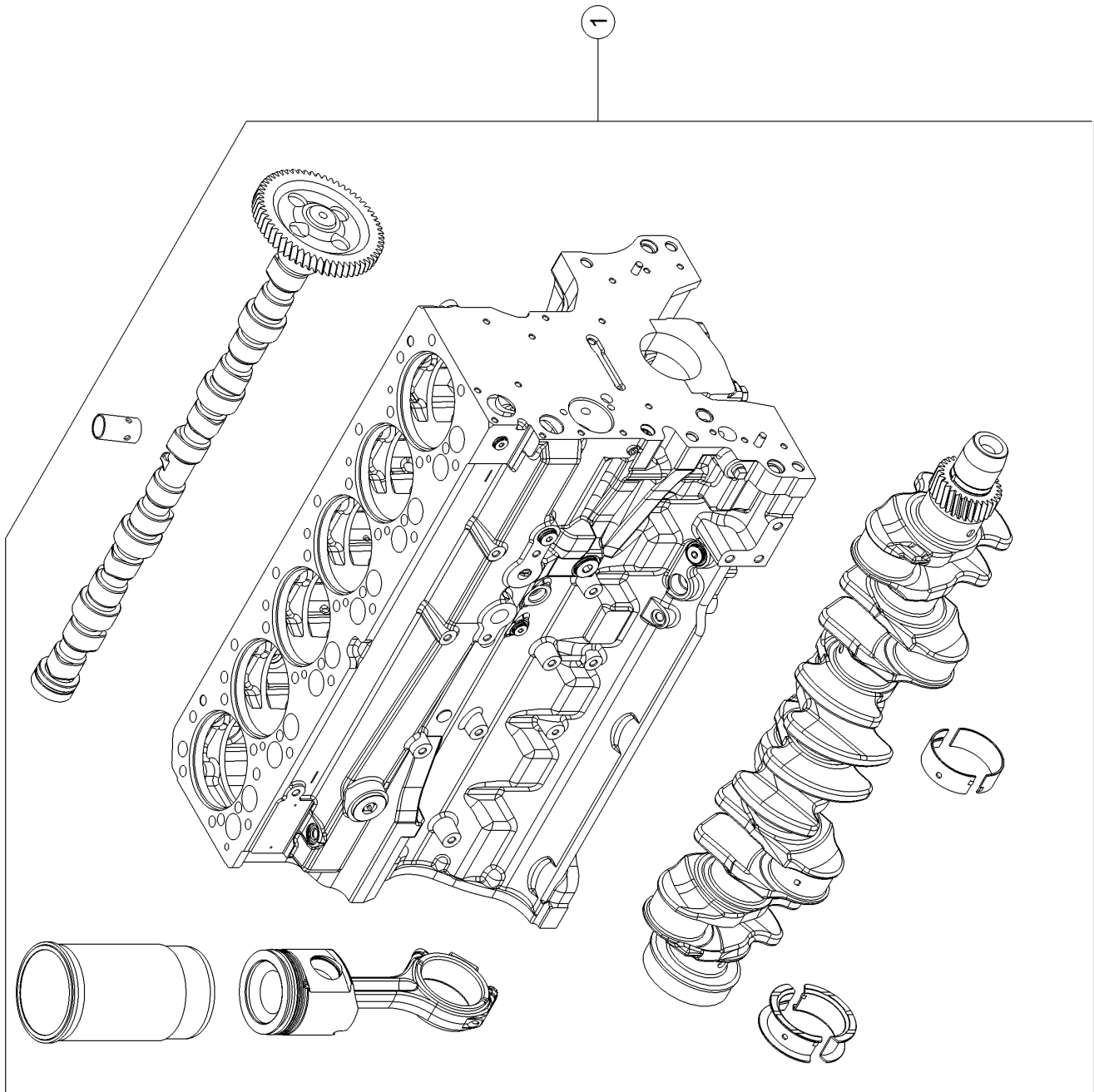

100 CRANKCASE 1)

Pos.	Part No.	Description	Dimension	Quantity	Conditions
1	00 1171 785 0	SHORT BLOCK		1	
1)	machine type	A77	+ ARION 660-610 St4 CMATIC		

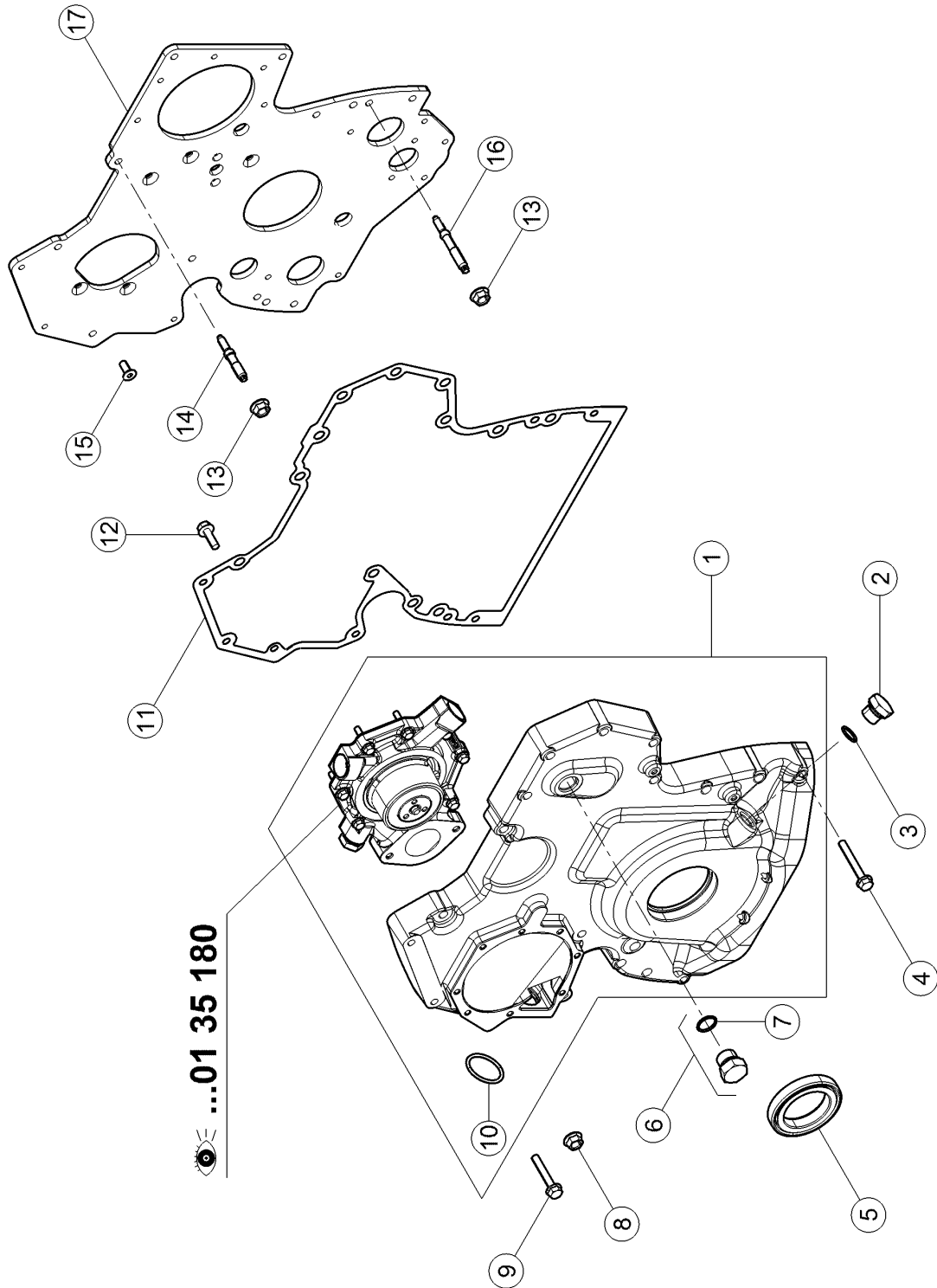

120 TIMING CASE 1)

Pos.	Part No.	Description	Dimension	Quantity	Conditions
1	00 1162 415 0	CASING		1	
2	60 0502 895 5	SCREW PLUG	F-M20X1,5	1	
3	60 0501 365 5	O-RING	17,3X2,2	1	
4	60 0502 145 0	SCREW	M08X60	4	
5	00 1169 885 0	GASKET		1	
6	60 0502 160 3	LOCK	M22X1,5	1	
7	60 0502 160 4	O-RING	19X2.4	1	
8	60 0502 144 9	NUT		9	
9	60 0502 593 6	SCREW	M8X50	4	
10	60 0500 796 4	O-RING	37,69 X 3,53 NBR 80	1	
11	00 1162 416 0	FLAT SEAL		1	
12	60 0502 145 6	SCREW	M8X25	1	
13	60 0502 144 9	NUT		9	
14	60 0502 339 8	STUD BOLT		2	
15	60 0502 339 7	SCREW		5	
16	00 1132 473 0	STUD BOLT		7	
17	00 1160 233 0	PLATE		1	

1) machine type

A75

+ ARION 550-510 St4 CMATIC

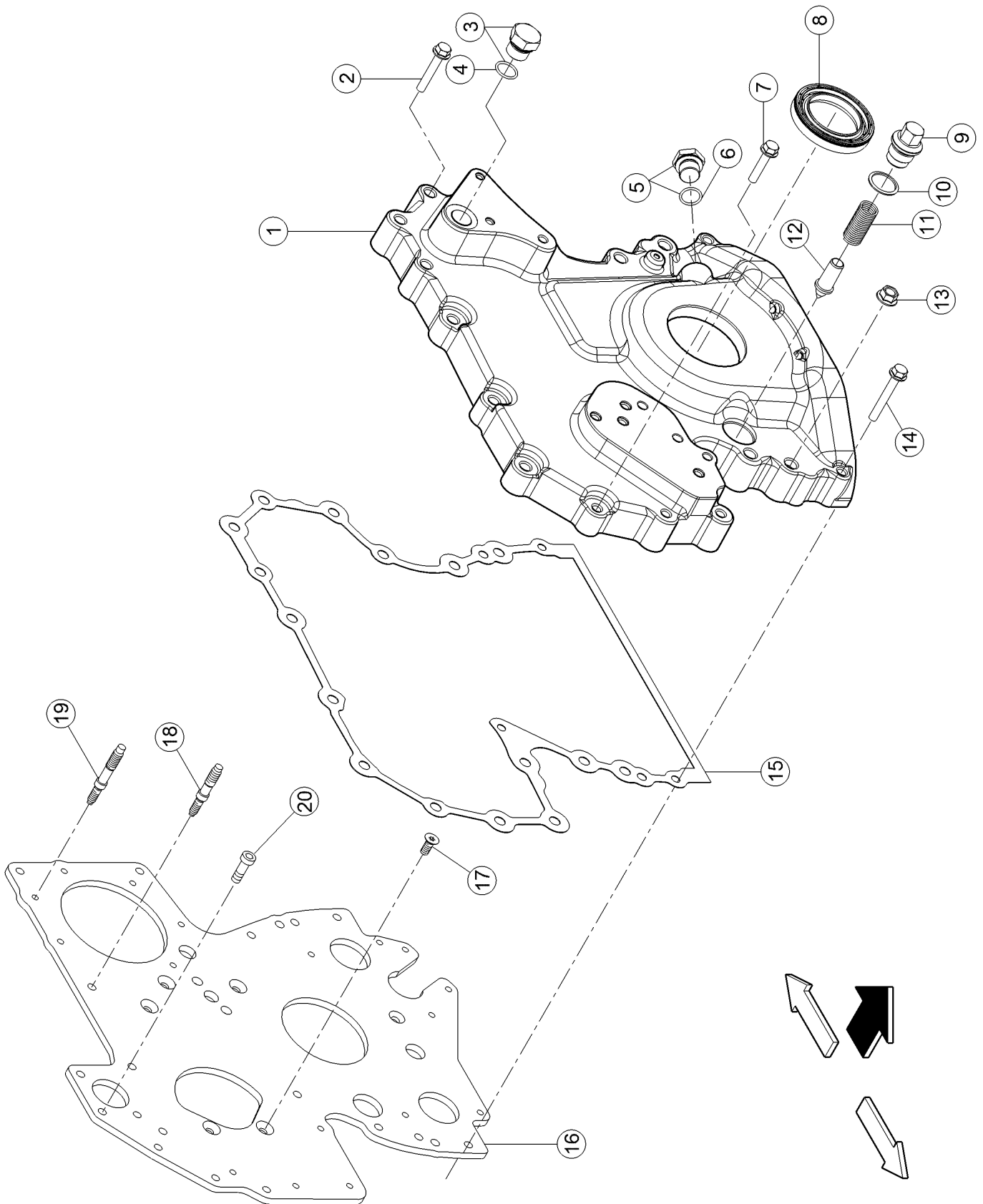

120 TIMING CASE 1)

Pos.	Part No.	Description	Dimension	Quantity	Conditions
1	00 1160 738 0	HOUSING		1	
2	60 0502 593 6	SCREW	M8X50	3	
3	60 0502 160 3	LOCK	M22X1,5	1	
4	60 0502 160 4	O-RING	19X2.4	1	
5	60 0502 895 5	SCREW PLUG	F-M20X1,5	1	
6	60 0501 365 5	O-RING	17,3X2,2	1	
7	60 0502 144 5	SCREW	M8X45	1	
8	00 1169 885 0	GASKET		1	
9	00 1165 194 0	PLUG		1	
10	60 0501 277 2	WASHER		1	
11	00 1165 195 0	SPRING		1	
12	00 1165 196 0	HYDRAULIC VALVE		1	
13	60 0502 144 9	NUT		8	
14	60 0502 145 0	SCREW	M08X60	3	
15	00 1160 737 0	FLAT SEAL		1	
16	00 1161 523 0	PLATE		1	
17	60 0502 339 7	SCREW		5	
18	60 0502 339 8	STUD BOLT		3	
19	00 1132 473 0	STUD BOLT		5	
20	77 0300 901 9	SCREW	M8X20 ERS.D.1070494.1	1	

1) machine type

A77

+ ARION 660-610 St4 CMATIC

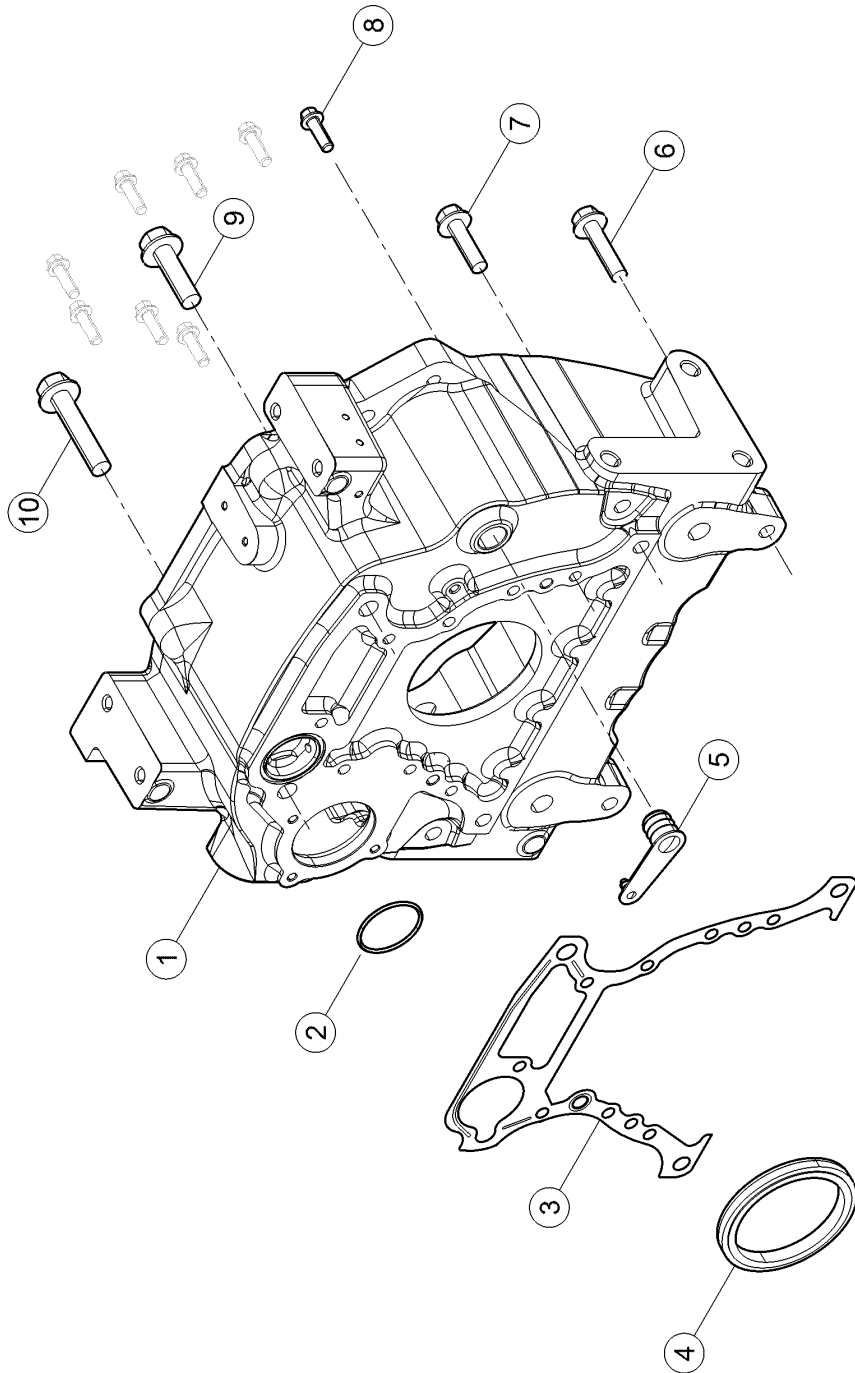

140 FLYWHEEL HOUSING

Pos.	Part No.	Description	Dimension	Quantity	Conditions
1	00 1161 402 0	CASING		1	
2	60 0501 604 9	O-RING		1	
3	77 0005 577 1	GASKET		1	
4	00 1169 730 0	LIP SEAL		1	
5	60 0501 611 6	BLANKING COVER		1	
6	60 0502 777 3	SCREW	M16X60	2	
7	60 0502 777 3	SCREW	M16X60	2	
8	60 0502 625 8	SCREW	12 X 1,75 -37 - M12X40	8	
9	00 1132 476 0	SCREW		1	
10	00 1132 477 0	SCREW	M20X100	1	

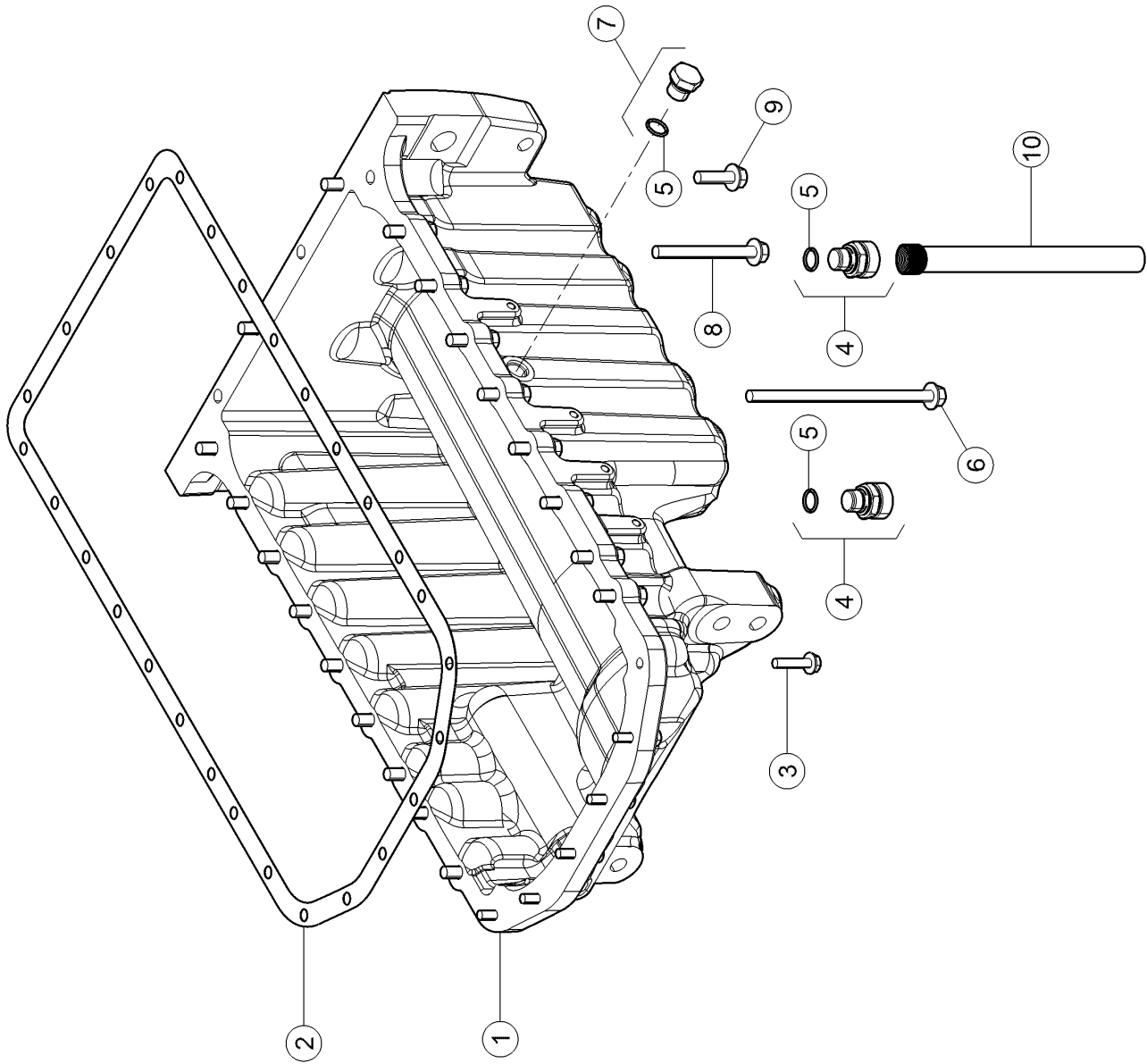

160 OIL PAN 1)

Pos.	Part No.	Description	Dimension	Quantity	Conditions
1	00 1166 987 0	OIL SUMP		1	
2	00 1166 771 0	FLAT SEAL		1	
3	60 0502 144 4	SCREW	M8X35	6	
4	00 1161 404 0	PLUG		2	
5	60 0502 160 8	O-RING	15,3X2,2-N	3	
6	00 1132 475 0	SCREW		2	
7	60 0502 160 7	PLUG	F-M18X1,5 ERS.D.7700054	1	
8	60 0502 625 3	SCREW	M10X100	2	
9	60 0502 165 4	SCREW	M10X35	18	
10	00 2611 791 0	RUBBER PIPE		1	

1) machine type

A75

+ ARION 550-510 St4 CMATIC

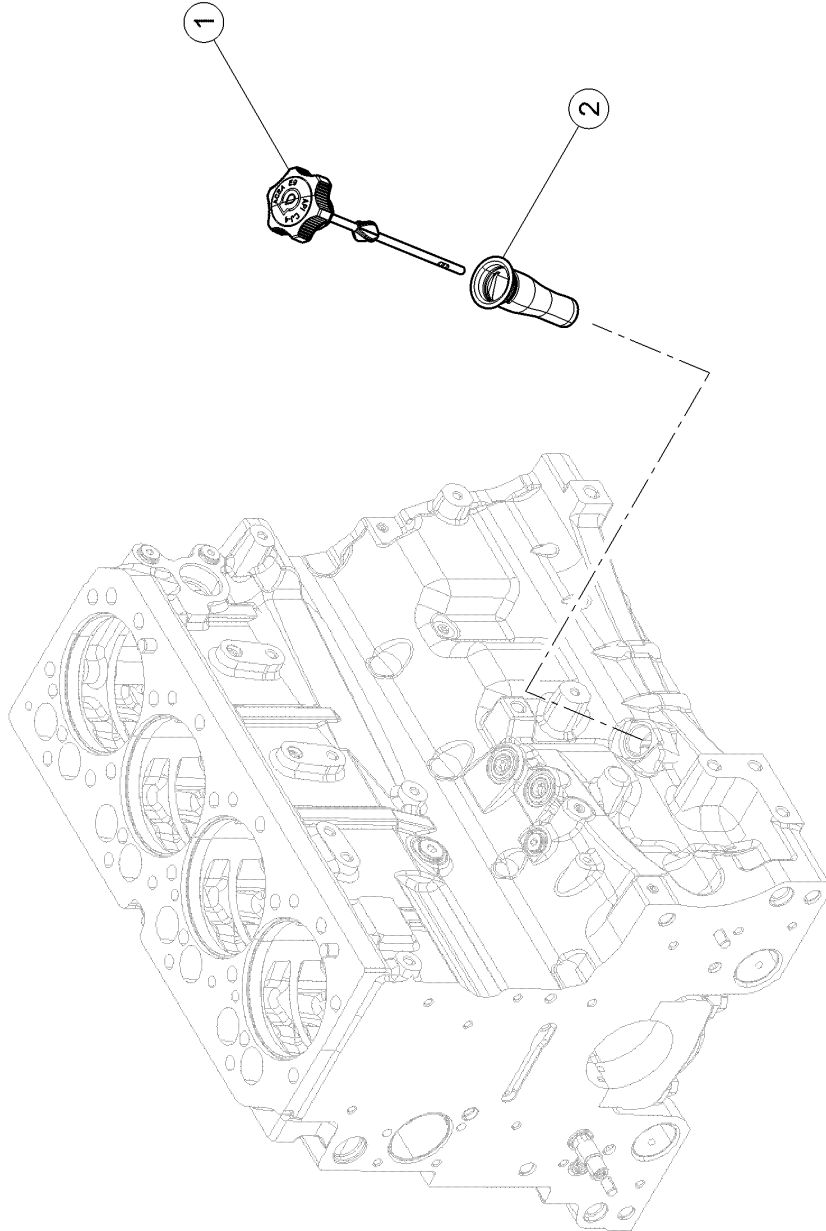

160 OIL PAN 1)

Pos.	Part No.	Description	Dimension	Quantity	Conditions
1	00 1145 355 0	GAUGE		1	
2	00 1146 111 0	TUBE		1	
1)	machine type	A75			+ ARION 550-510 St4 CMATIC

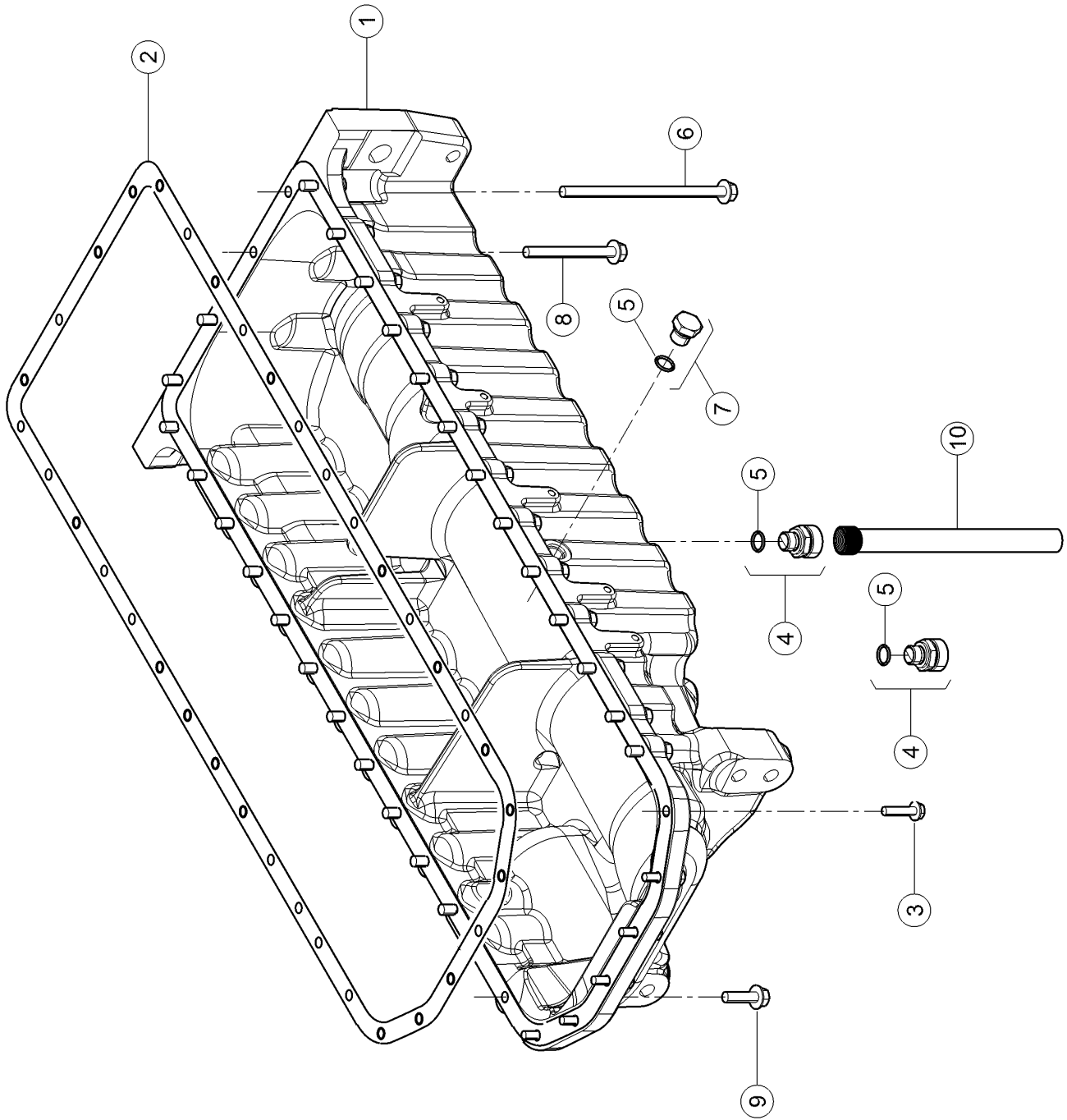

160 OIL PAN 1)

Pos.	Part No.	Description	Dimension	Quantity	Conditions
1	00 1166 988 0	OIL SUMP		1	
2	00 1166 770 0	FLAT SEAL		1	
3	00 1161 525 0	STD SCREW		6	
4	00 1161 404 0	PLUG		2	
5	60 0502 160 8	O-RING	15,3X2,2-N	3	
6	00 1132 475 0	SCREW		2	
7	60 0502 160 7	PLUG	F-M18X1,5 ERS.D.7700054	1	
8	60 0502 625 3	SCREW	M10X100	2	
9	60 0502 165 4	SCREW	M10X35	26	
10	00 2611 791 0	RUBBER PIPE		1	

1) machine type

A77

+ ARION 660-610 St4 CMATIC

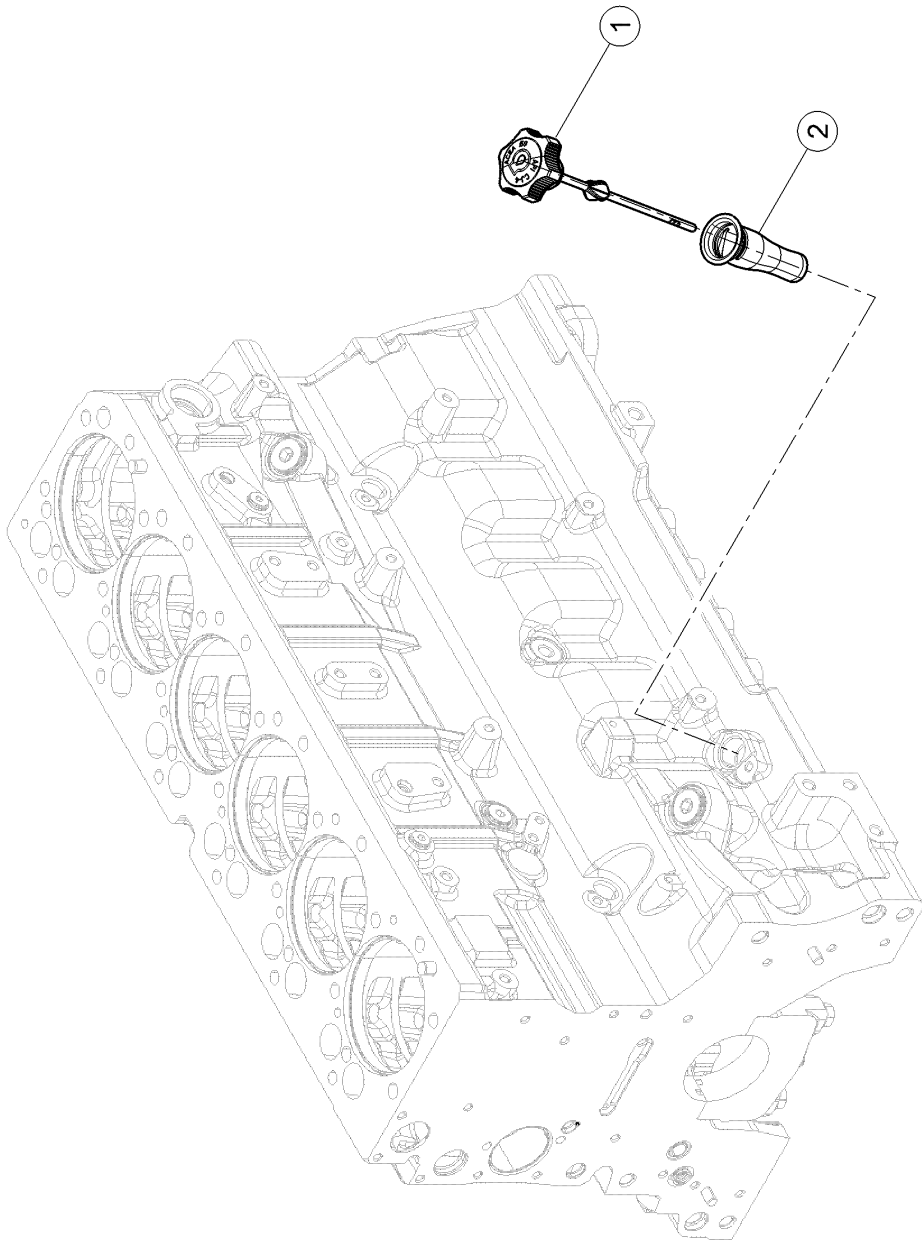

160 OIL PAN 1)

Pos.	Part No.	Description	Dimension	Quantity	Conditions
1	00 1145 355 0	GAUGE		1	
2	00 1161 526 0	TUBE		1	
1)	machine type	A77			+ ARION 660-610 St4 CMATIC

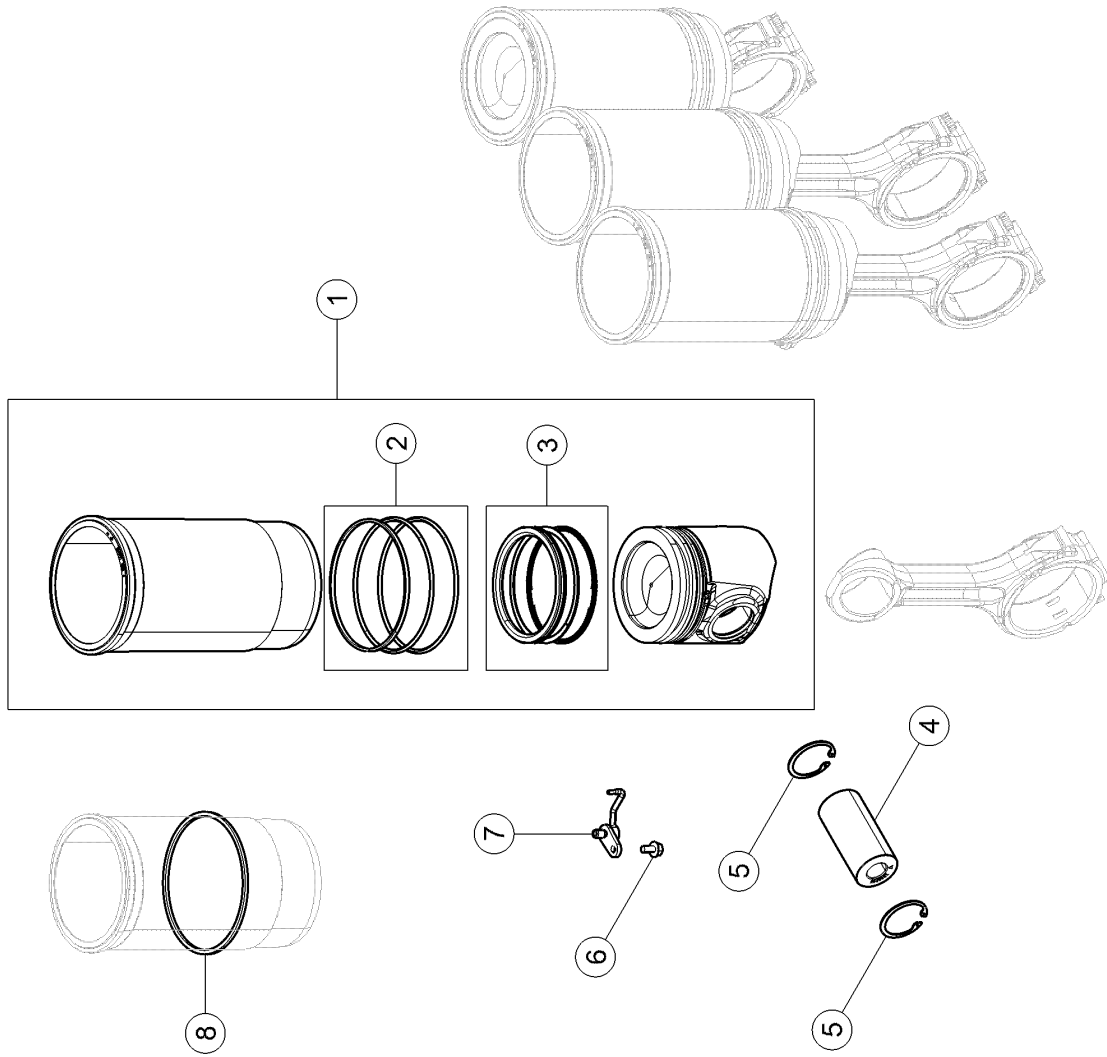

100 CYLINDER LINER, PISTON 1)

Pos.	Part No.	Description	Dimension	Quantity	Conditions
1	00 1166 970 0	PISTON-LINER		4	
2	00 1146 460 0	SEALING RING SET		4	
3	00 1164 944 0	SET OF PISTON RINGS		4	
4	00 1167 613 0	SHAFT		4	
5	60 0501 281 4	INNER CIRCLIP		8	
6	00 1145 889 0	SCREW		4	
7	00 1145 888 0	NOZZLE		4	
8	60 0501 281 5	ADJUSTING DISC		4	2)
8	60 0501 281 6	ADJUSTING DISC		4	3)
1)	machine type	A75	+ ARION 550-510 St4 CMATIC		
2)	Remarks		[SR]EP.0.05MM		
3)	Remarks		[SR]EP.0.10MM		

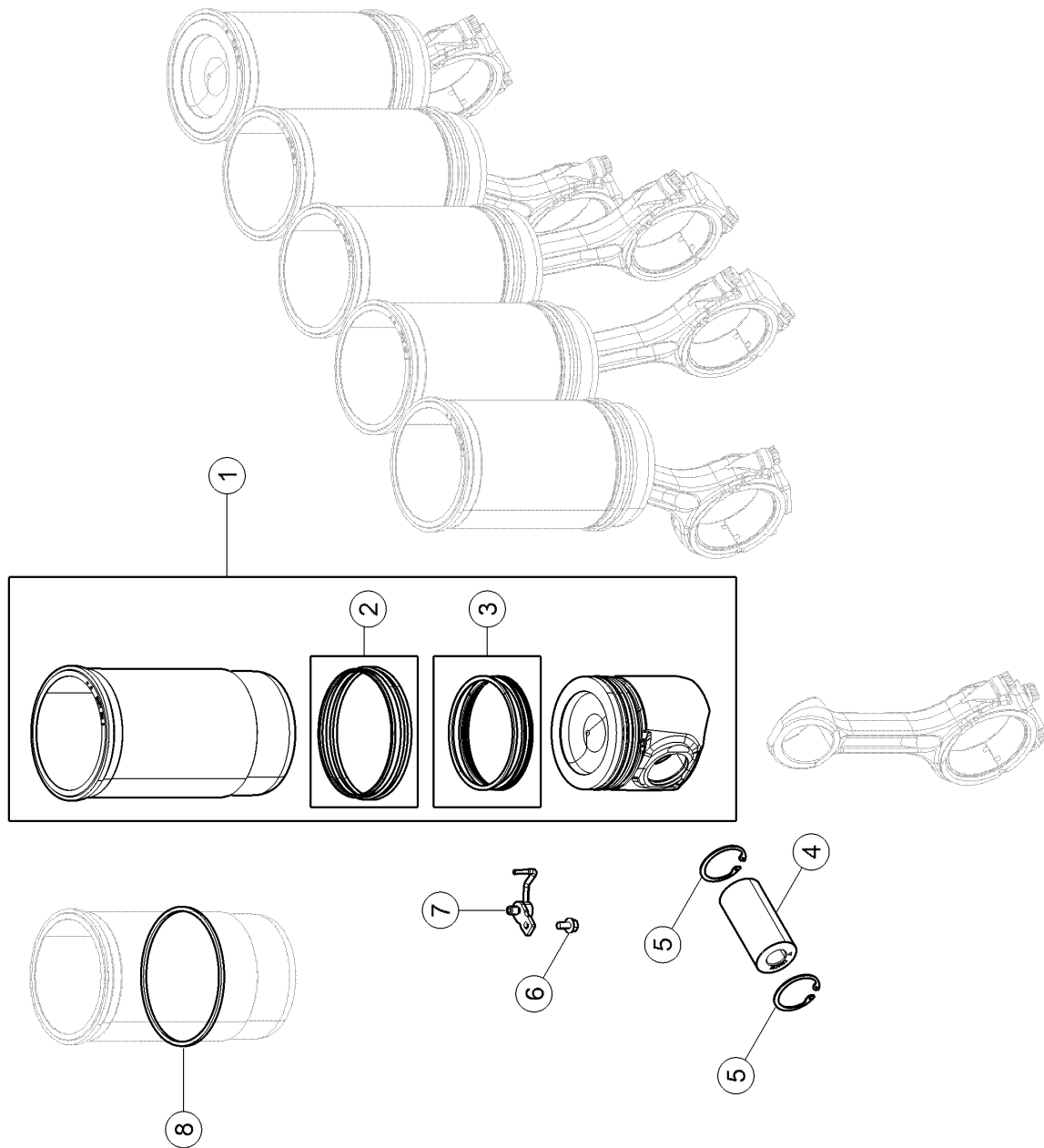

100 CYLINDER LINER, PISTON 1)

Pos.	Part No.	Description	Dimension	Quantity	Conditions
1	00 1166 971 0	PISTON-LINER		6	
2	00 1146 460 0	SEALING RING SET		6	
3	00 1164 944 0	SET OF PISTON RINGS		6	
4	00 1167 613 0	SHAFT		6	
5	60 0501 281 4	INNER CIRCLIP		12	
6	00 1145 889 0	SCREW		6	
7	00 1161 528 0	NOZZLE		6	
8	60 0501 281 5	ADJUSTING DISC		6	2)
8	60 0501 281 6	ADJUSTING DISC		6	3)
1)	machine type	A77	+ ARION 660-610 St4 CMATIC		
2)	Remarks		[SR] EP 0.05MM		
3)	Remarks		[SR] EP 0.10MM		

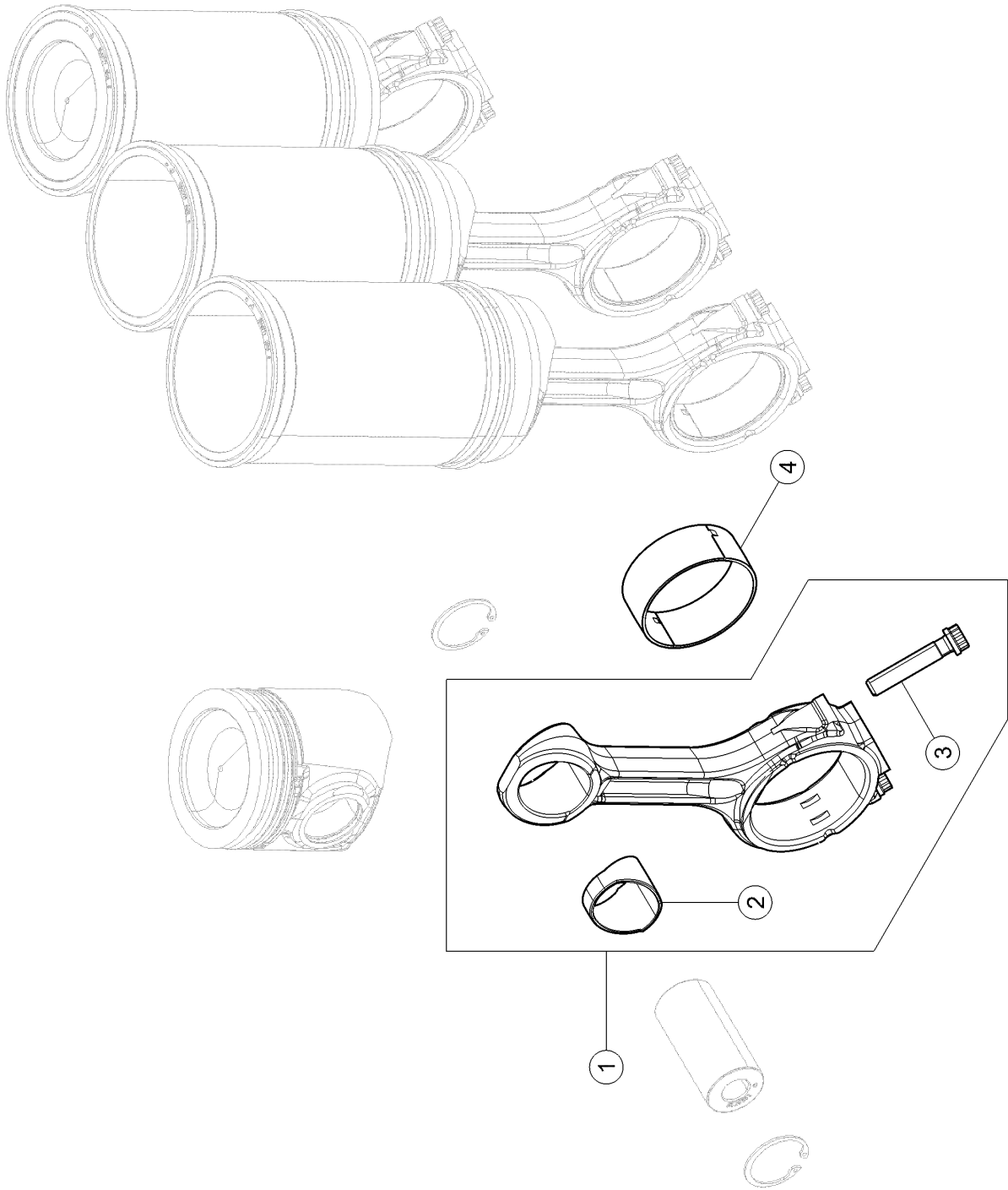

120 CONNECTING ROD, CONNECTING ROD BEARINGS 1)

Pos.	Part No.	Description	Dimension	Quantity	Conditions
1	60 0502 453 6	CONNECTING ROD		4	
2	60 0502 147 6	RING		4	
3	60 0502 453 7	SCREW	12 PTS M12 X 1,25 - 61	8	
4	60 0502 147 8	BEARING		4	2)
4	60 0502 147 9	BEARING		4	3)
1)	machine type	A75	+ ARION 550-510 St4 CMATIC		
2)	Remarks		Standard		
3)	Remarks		-0.254MM		

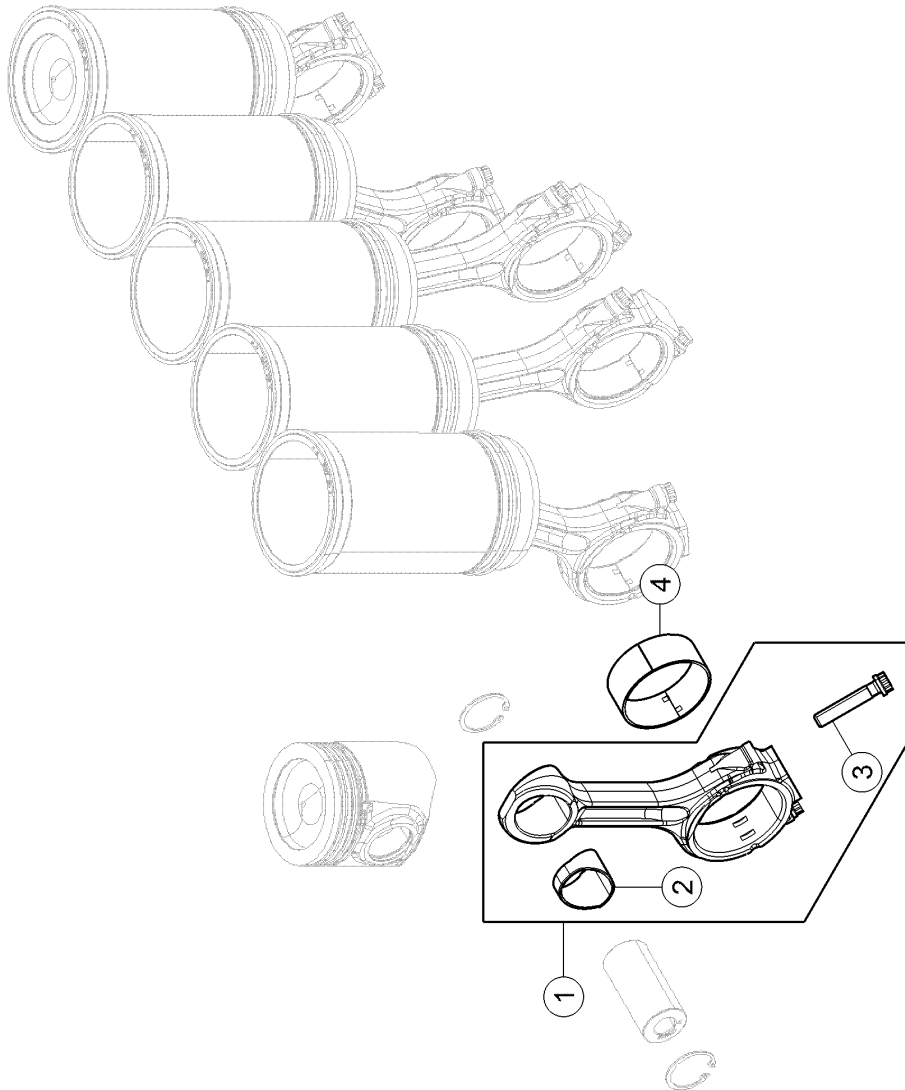

120 CONNECTING ROD, CONNECTING ROD BEARINGS 1)

Pos.	Part No.	Description	Dimension	Quantity	Conditions
1	60 0502 453 6	CONNECTING ROD		6	
2	60 0502 147 6	RING		6	
3	60 0502 453 7	SCREW	12 PTS M12 X 1,25 - 61	12	
4	00 1146 461 0	BEARING BUSH		6	
1)	machine type	A77	+ ARION 660-610 St4 CMATIC		

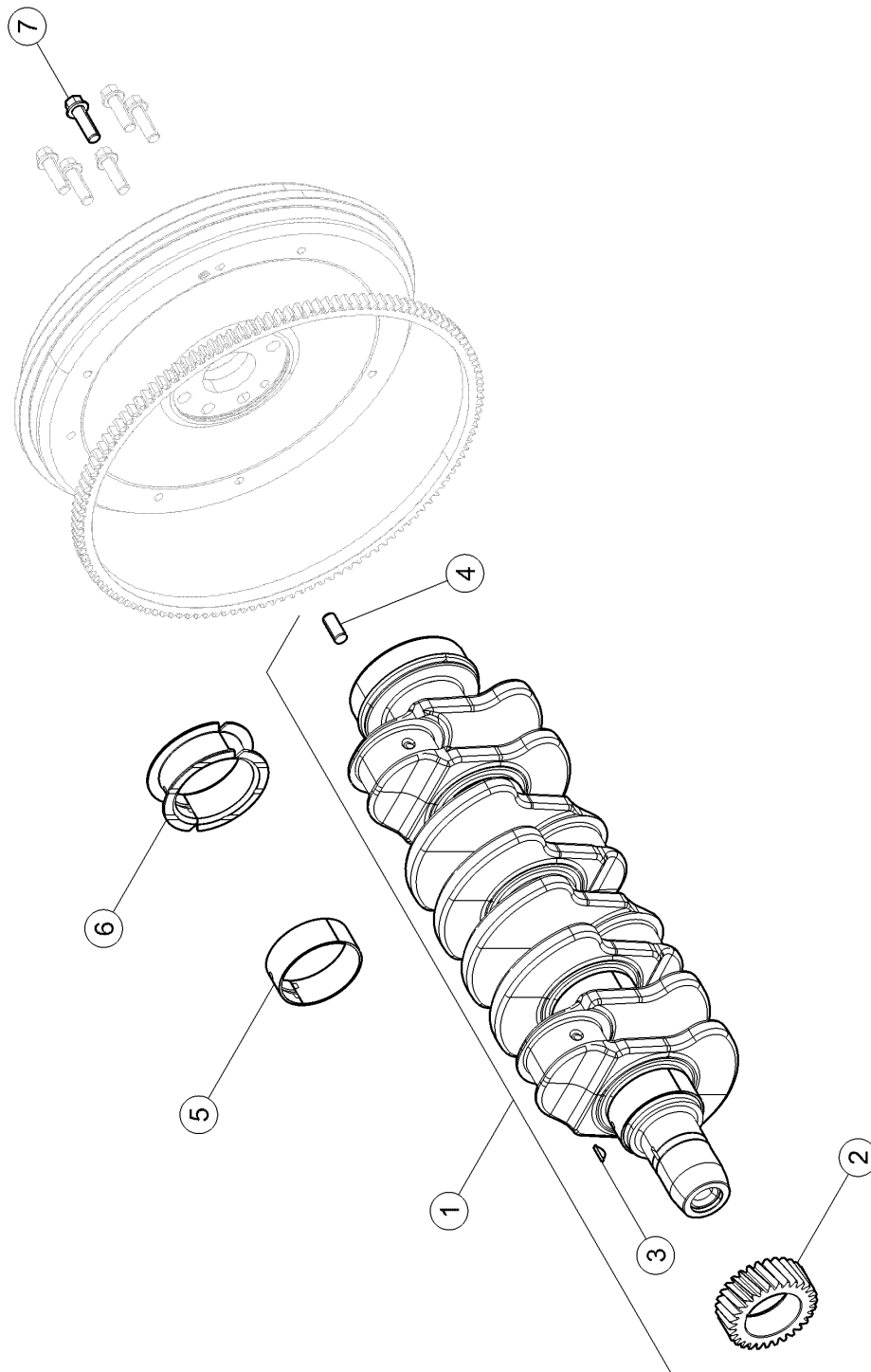



Suggest:

For more complete manuals. Please go to the home page.

<https://www.ebooklibonline.com>

If the above button click is invalid. Please download this document first, and then click the above link to download the complete manual.

Thank you so much for reading

140 CRANKSHAFT 1)

Pos.	Part No.	Description	Dimension	Quantity	Conditions
1	00 1145 892 0	CRANKSHAFT		1	
2	60 0502 148 5	WHEEL		1	
3	60 0502 869 7	KEY		1	
4	60 0501 317 4	CENTRING PIN		1	
5	60 0502 148 3	BEARING		4	2)
5	60 0502 148 4	BEARING		4	3)
6	60 0502 148 1	BEARING		1	2)
6	60 0502 148 2	BEARING		1	3)
7	00 1164 945 0	STD SCREW		6	
<hr/>					
1)	machine type	A75	+ ARION 550-510 St4 CMATIC		
<hr/>					
2)	Remarks		Standard		
<hr/>					
3)	Remarks		-0.254MM		
<hr/>					

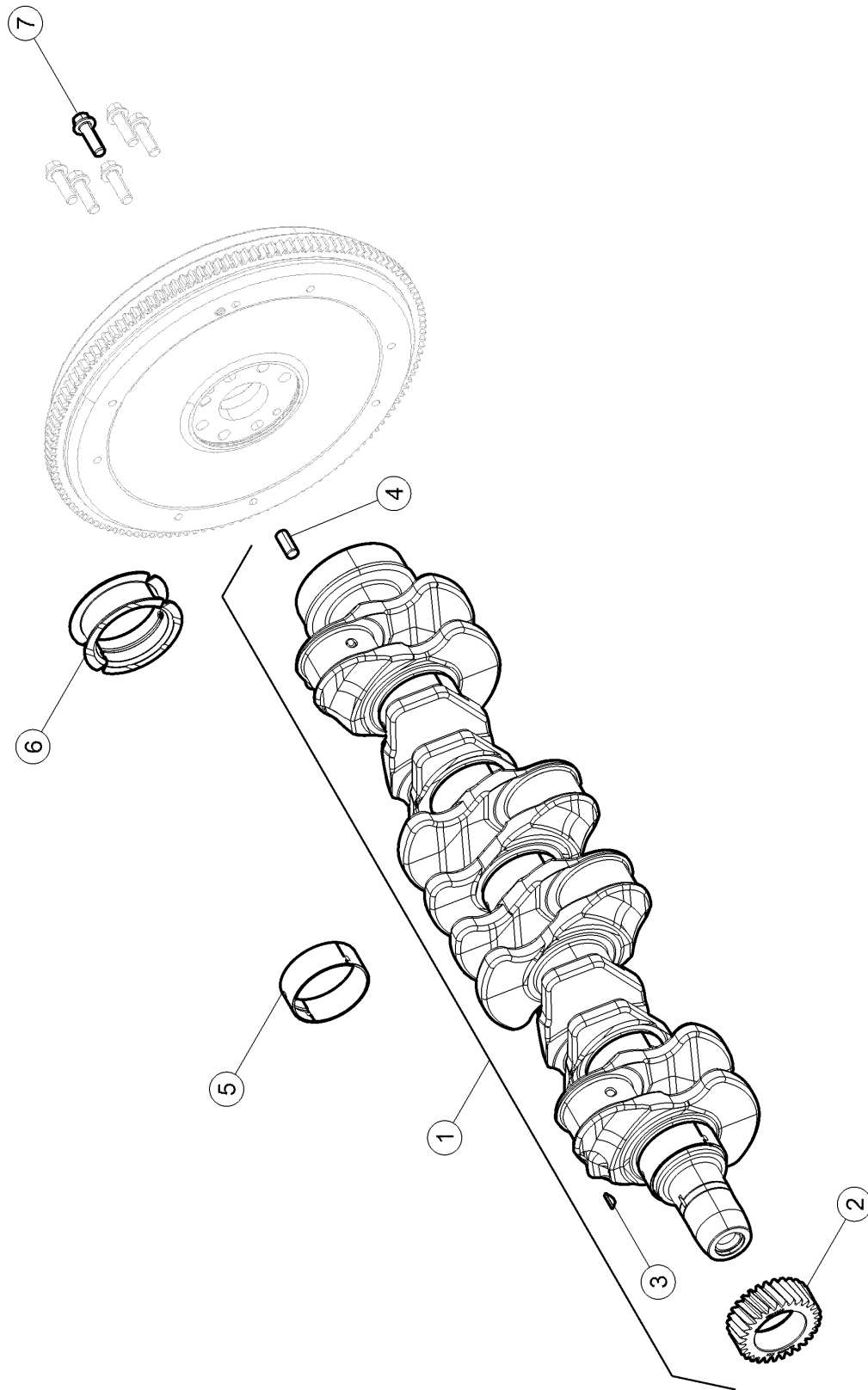

140 CRANKSHAFT 1)

Pos.	Part No.	Description	Dimension	Quantity	Conditions
1	00 1161 529 0	CRANKSHAFT		1	
2	00 1161 535 0	GEAR		1	
3	60 0502 869 7	KEY		1	
4	60 0501 317 4	CENTRING PIN		1	
5	60 0502 148 3	BEARING		6	2)
5	60 0502 148 4	BEARING		6	3)
6	60 0502 148 1	BEARING		1	2)
6	60 0502 148 2	BEARING		1	3)
7	60 0502 625 8	SCREW	12 X 1,75 -37 - M12X40	6	

1) machine type

A77

+ ARION 660-610 St4 CMATIC

2) Remarks

Standard

3) Remarks

-0.254MM

<https://www.ebooklibonline.com>

Hello dear friend!

Thank you very much for reading.

Enter the link into your browser.

The full manual is available for immediate download.

<https://www.ebooklibonline.com>