

010 COMPLETE ENGINE

Pos.	Part No.	Description	Dimension	Quantity	Conditions
1	00 2182 012 0	ENGINE		1	1)
1	00 2182 014 0	ENGINE		1	2)
1	00 2182 016 0	ENGINE		1	3)
1) Equipment					
		TD_P02_0110	140 hp rated output, 145 hp max. output, ECE R 120		
		TD_P02_0115	140 hp rated output, 145 hp max. output, ECE R 120		
2) Equipment					
		TD_P02_0120	150 hp rated output, 155 hp max. output, ECE R 120		
		TD_P02_0125	150 hp rated output, 155 hp max. output, ECE R 120		
3) Equipment					
		TD_P02_0130	158 hp rated output, 163 hp max. output, ECE R 120		

<https://www.ebooklibonline.com>

Hello dear friend!

Thank you very much for reading.

Enter the link into your browser.

The full manual is available for immediate download.

<https://www.ebooklibonline.com>

100 CRANKCASE

Pos.	Part No.	Description	Dimension	Quantity	Conditions
1	60 0502 905 2	PLUG		2	
2	60 0502 339 4	O-RING		2	
3	60 0501 597 1	LOCK		1	
4	60 0501 320 3	O-RING		1	
5	60 0501 319 6	CENTRING PIN		2	
6	00 1145 874 0	SCREW		10	
7	60 0502 593 1	RING		6	
8	00 1145 875 0	VALVE		1	
9	60 0502 869 1	VALVE		1	
10	60 0501 319 8	BLANKING COVER		2	
11	60 0501 294 1	BEARING		1	
12	60 0502 145 6	SCREW	M8X25	2	
13	60 0502 151 1	PLATE		1	
14	60 0502 143 9	BLANKING COVER		1	
15	00 1141 206 0	PLUG		5	
16	00 1145 876 0	PLUG		1	
17	60 0502 160 8	O-RING	15,3X2,2-N	1	
18	60 0501 317 4	CENTRING PIN		4	
19	60 0502 164 1	O-RING		1	
20	00 1145 880 0	PLUG		1	
21	60 0501 320 1	SPRING		1	

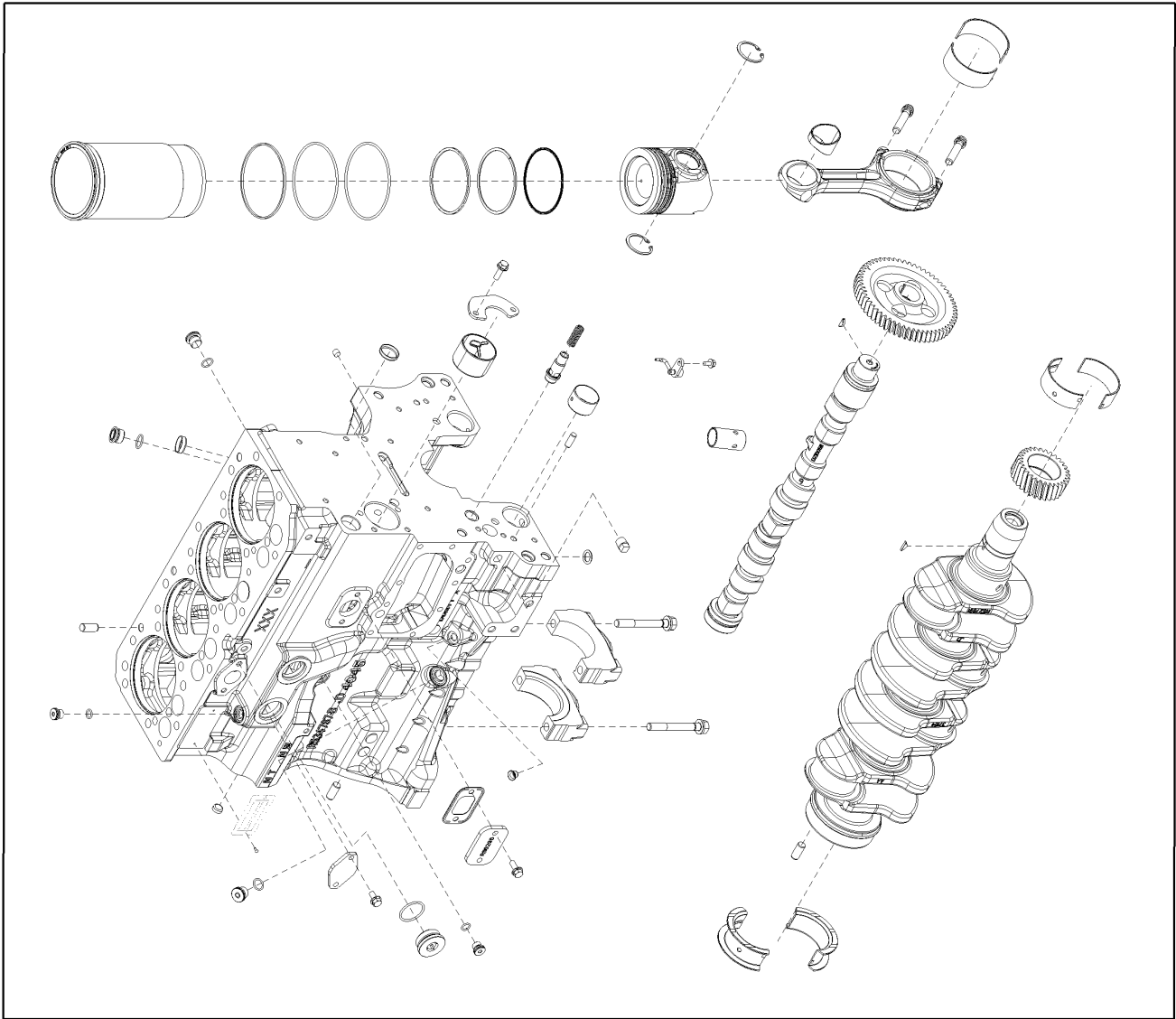

1

100 CRANKCASE

Pos.	Part No.	Description	Dimension	Quantity	Conditions
1	00 1169 727 0	SHORT BLOCK		1	

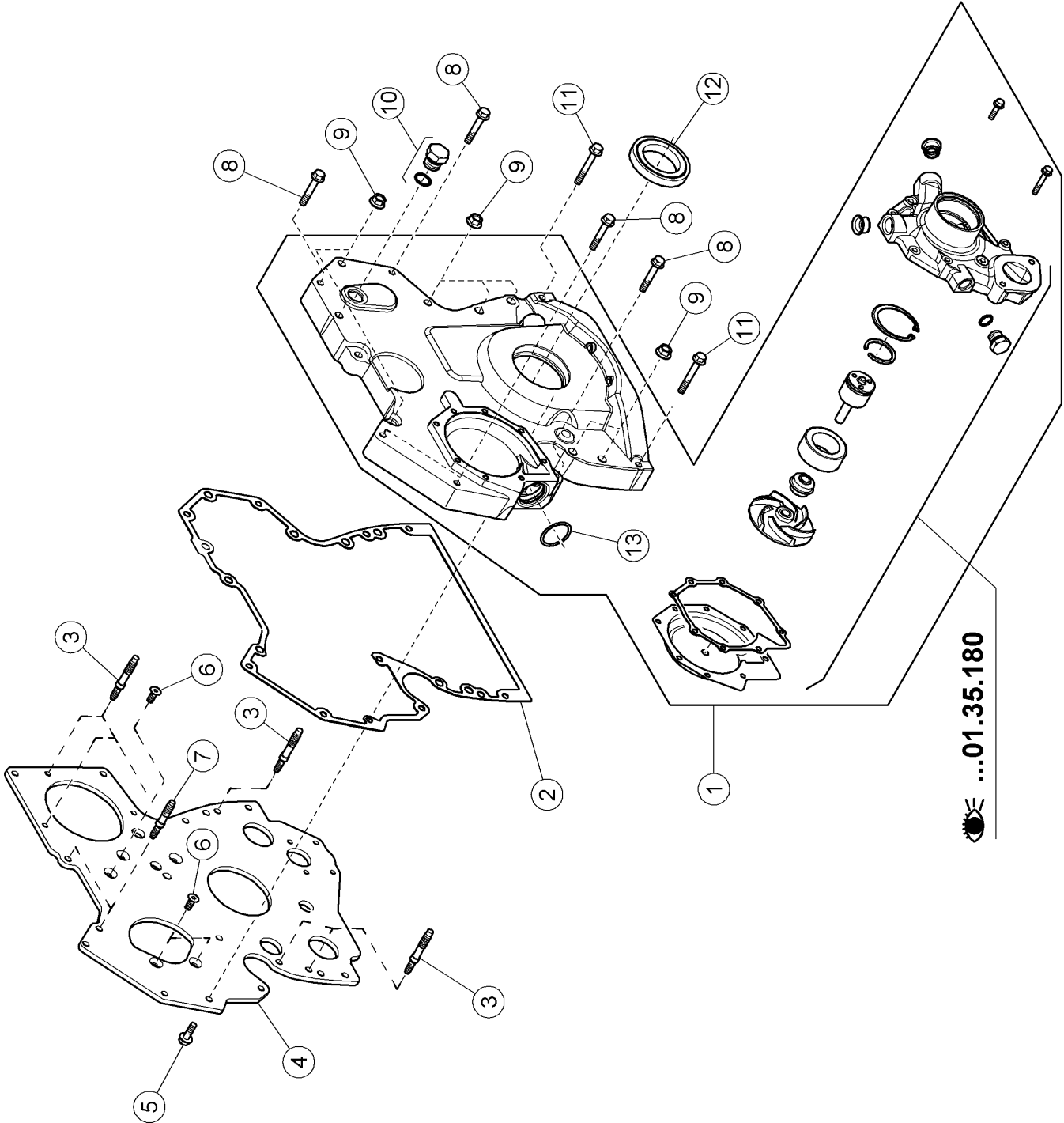

120 TIMING CASE

Pos.	Part No.	Description	Dimension	Quantity	Conditions
1	00 1162 415 0	CASING		1	
2	00 1162 416 0	FLAT SEAL		1	
3	00 1132 473 0	STUD BOLT		7	
4	00 1160 233 0	PLATE		1	
5	60 0502 145 6	SCREW	M8X25	1	
6	60 0502 339 7	SCREW		5	
7	60 0502 339 8	STUD BOLT		2	
8	60 0502 593 6	SCREW	M8X50	4	
9	60 0502 144 9	NUT		9	
10	60 0502 160 3	LOCK	M22X1,5	1	
11	60 0502 145 0	SCREW	M08X60	4	
12	00 1169 885 0	GASKET		1	
13	60 0500 796 4	O-RING	37,69 X 3,53 NBR 80	1	

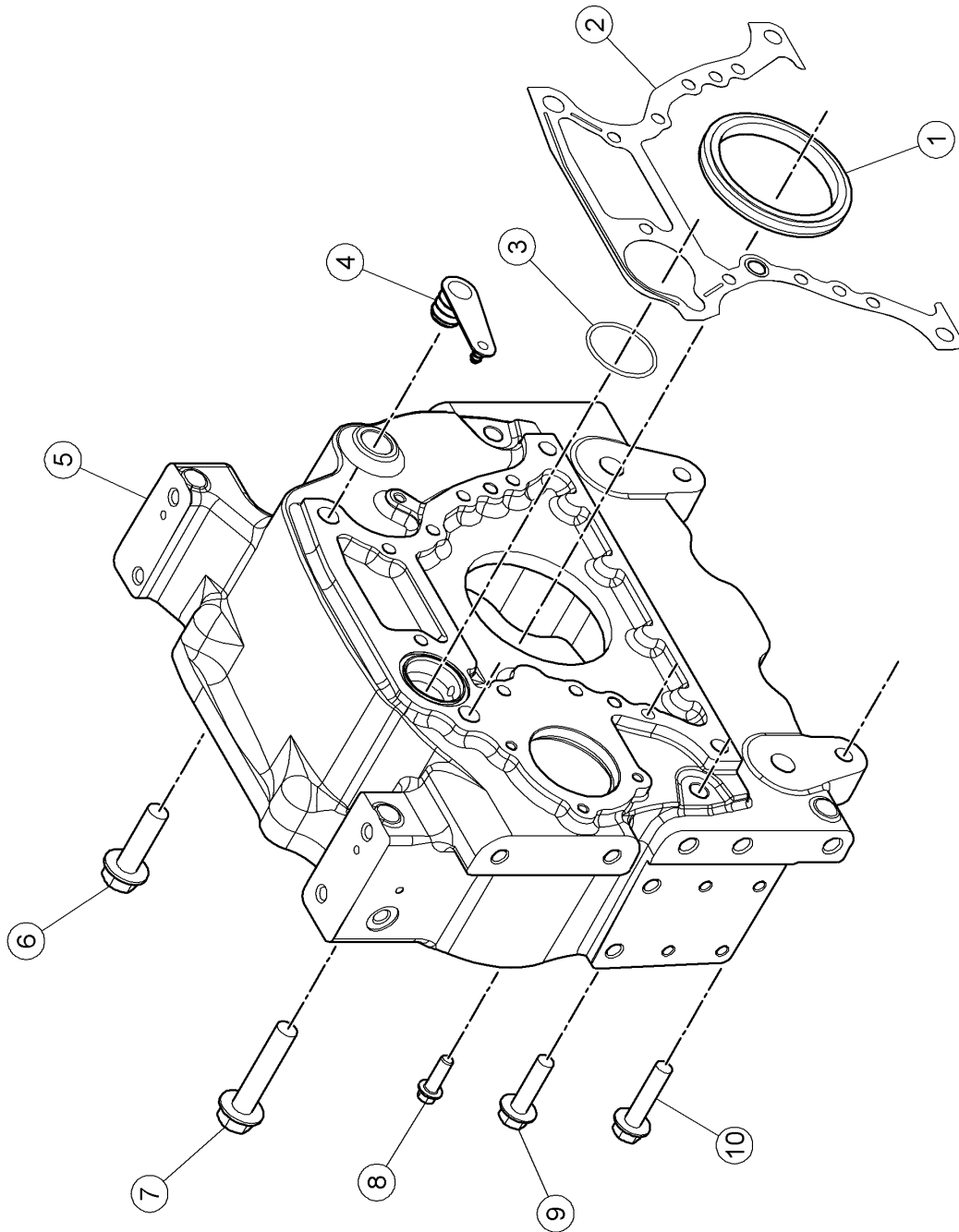

140 FLYWHEEL HOUSING

Pos.	Part No.	Description	Dimension	Quantity	Conditions
1	00 1169 730 0	LIP SEAL		1	
2	77 0005 577 1	GASKET		1	
3	60 0501 604 9	O-RING		1	
4	60 0501 611 6	BLANKING COVER		1	
5	00 1145 878 0	CASING		1	
6	00 1132 476 0	SCREW		1	
7	00 1132 477 0	SCREW	M20X100	1	
8	60 0502 625 8	SCREW	12 X 1,75 -37 - M12X40	8	
9	60 0502 777 3	SCREW	M16X60	2	
10	60 0502 777 3	SCREW	M16X60	2	

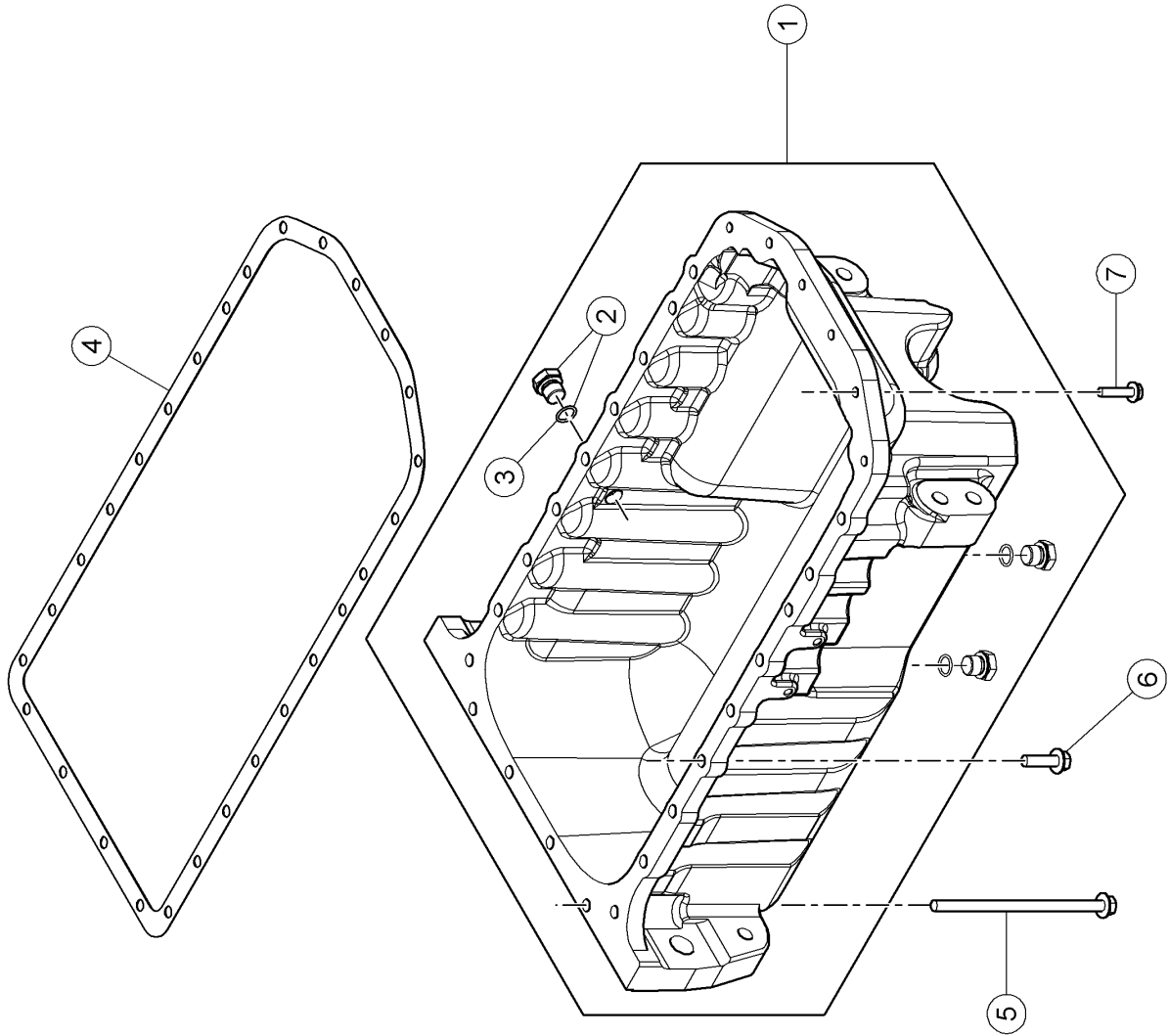

160 OIL PAN

Pos.	Part No.	Description	Dimension	Quantity	Conditions
1	00 1145 879 0	CASING		1	
2	60 0502 160 7	PLUG	F-M18X1,5 ERS.D.7700054	3	
3	60 0502 160 8	O-RING	15,3X2,2-N	3	
4	00 1168 595 0	FLAT SEAL		1	
5	00 1132 475 0	SCREW		4	
6	60 0502 165 4	SCREW	M10X35	18	
7	60 0502 144 4	SCREW	M8X35	6	

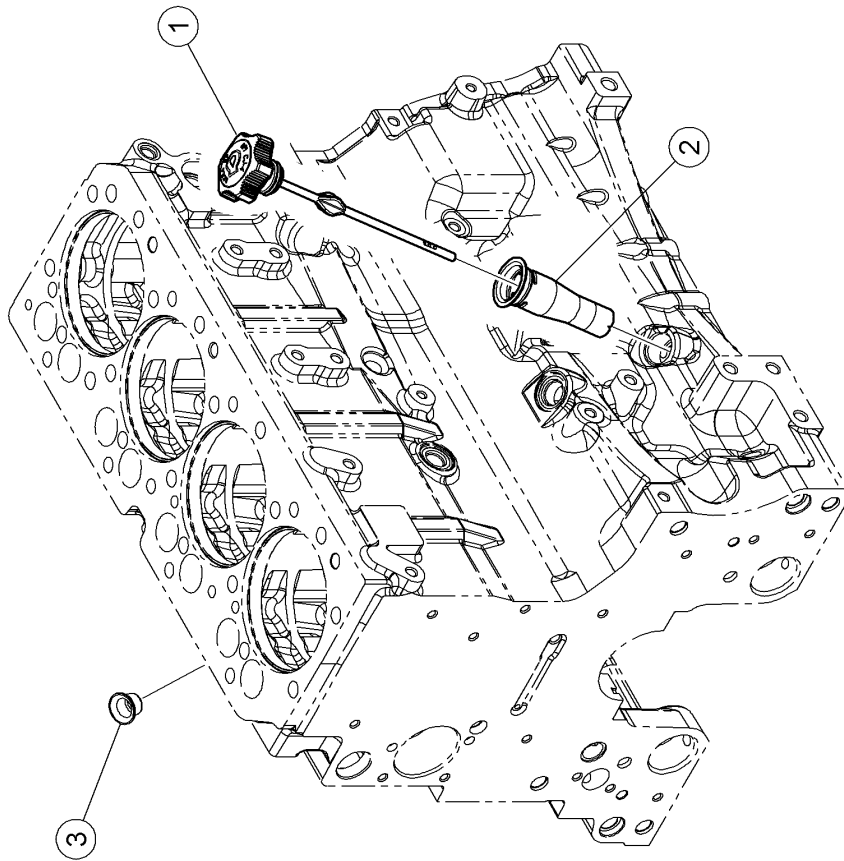

160 OIL PAN

Pos.	Part No.	Description	Dimension	Quantity	Conditions
1	00 1145 355 0	GAUGE		1	
2	00 1146 111 0	TUBE		1	
3	60 0502 662 4	PLUG		1	

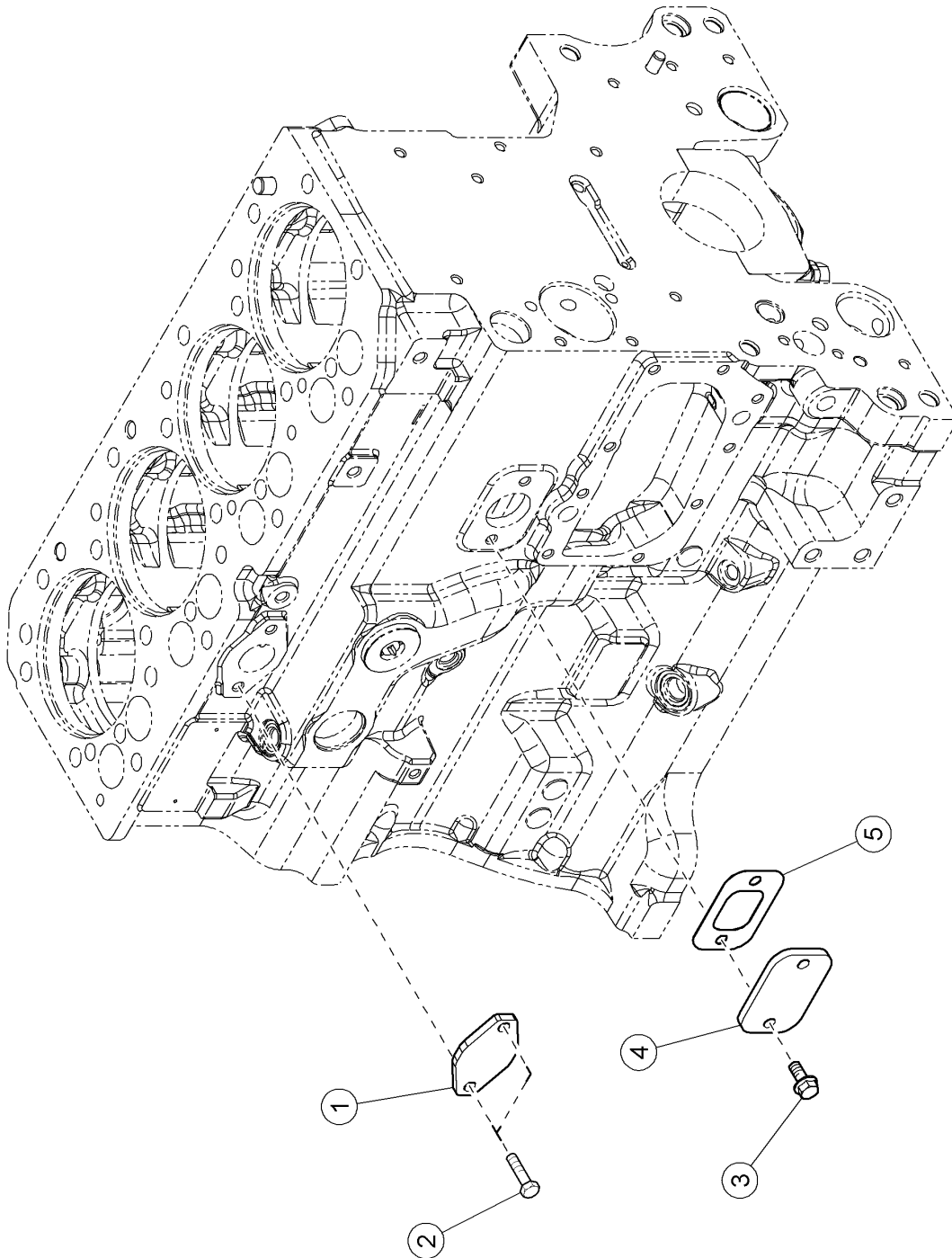

180 PLUGS

Pos.	Part No.	Description	Dimension	Quantity	Conditions
1	60 0502 662 2	PLATE		1	
2	60 0502 662 3	SCREW		2	
3	60 0502 149 8	SCREW	M8X20	2	
4	60 0502 470 2	PLATE		1	
5	60 0502 470 4	GASKET		1	

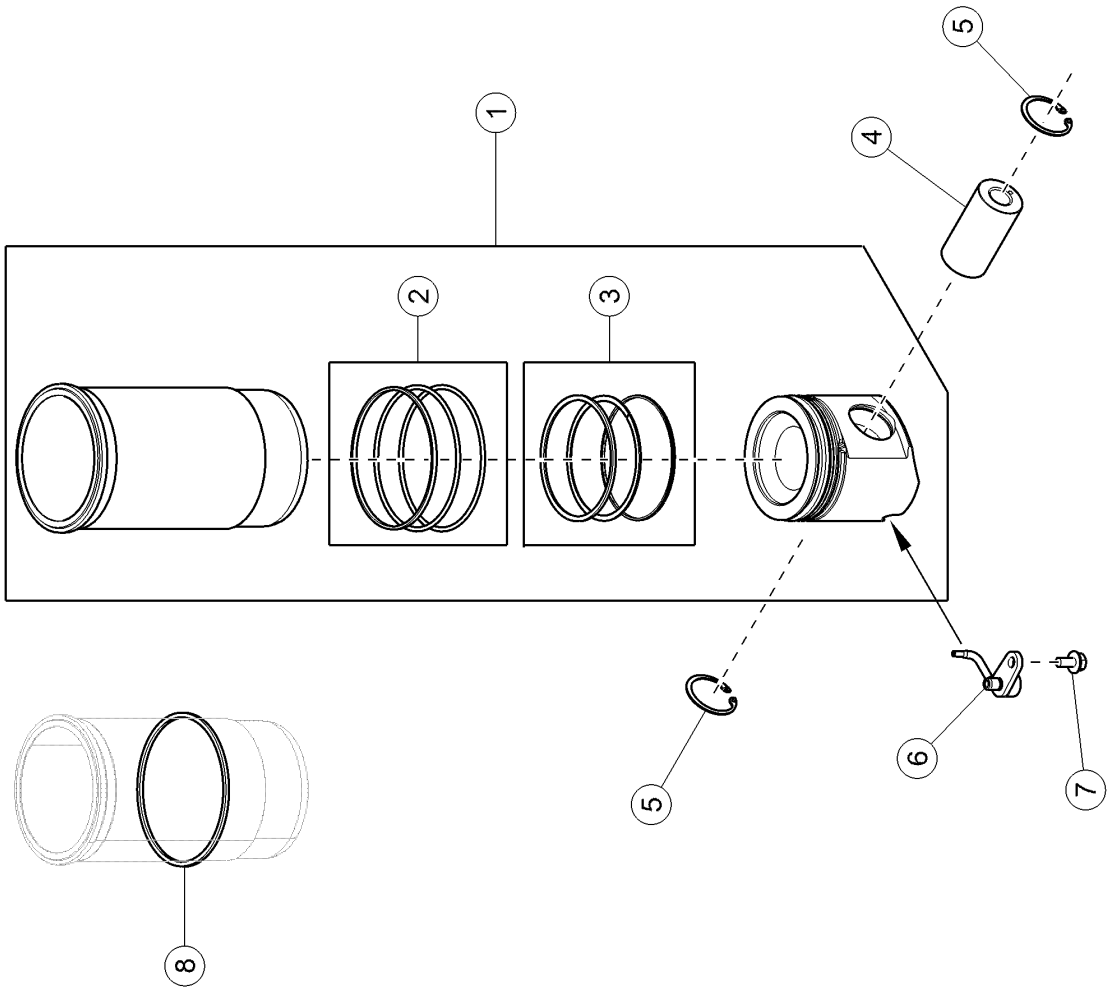

100 CYLINDER LINER, PISTON

Pos.	Part No.	Description	Dimension	Quantity	Conditions
1	00 1166 931 0	PISTON-LINER		4	
2	60 0501 280 9	SEALING RING SET		4	
3	00 1145 886 0	SET OF PISTON RINGS		4	
4	00 1145 887 0	AXLE		4	
5	60 0501 281 4	INNER CIRCLIP		8	
6	00 1145 888 0	NOZZLE		4	
7	00 1145 889 0	SCREW		4	
8	60 0501 281 5	ADJUSTING DISC		4	1)
8	60 0501 281 6	ADJUSTING DISC		4	2)
1)	Remarks		[SR] EP 0.05MM		
2)	Remarks		[SR] EP 0.10MM		

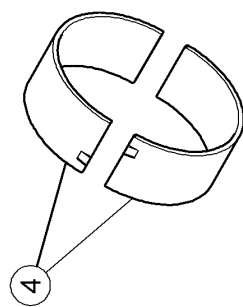
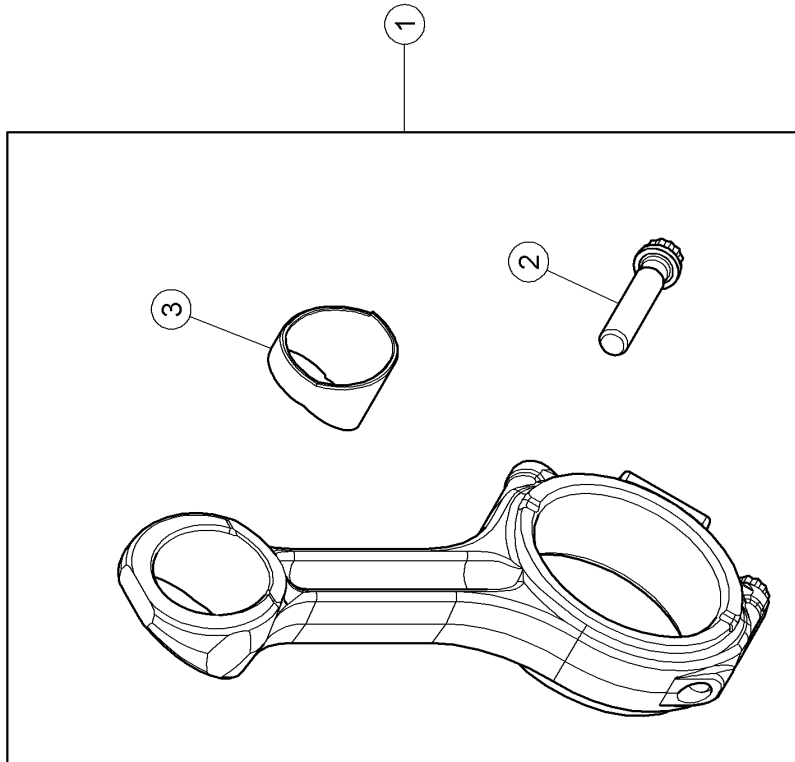

120 CONNECTING ROD, CONNECTING ROD BEARINGS

Pos.	Part No.	Description	Dimension	Quantity	Conditions
1	60 0502 453 6	CONNECTING ROD		4	
2	60 0502 453 7	SCREW	12 PTS M12 X 1,25 - 61	8	
3	60 0502 147 6	RING		4	
4	60 0502 147 8	BEARING		4	1)
4	60 0502 147 9	BEARING		4	2)
1)	Remarks		Standard		
2)	Remarks		-0.254MM		

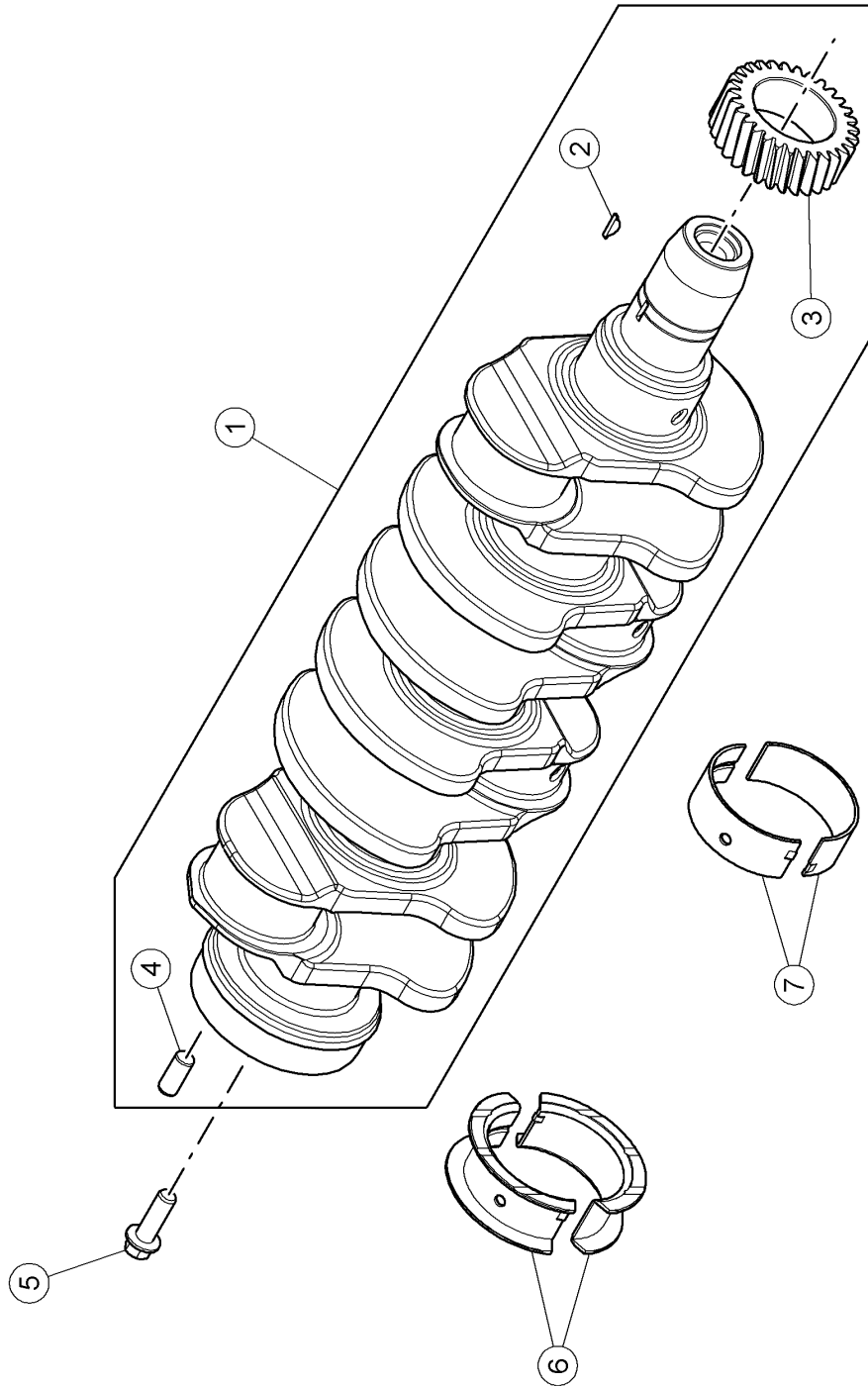

140 CRANKSHAFT

Pos.	Part No.	Description	Dimension	Quantity	Conditions
1	00 1145 892 0	CRANKSHAFT		1	
2	60 0502 869 7	KEY		1	
3	60 0502 148 5	WHEEL		1	
4	60 0501 317 4	CENTRING PIN		1	
5	60 0502 625 8	SCREW	12 X 1,75 -37 - M12X40	6	
6	60 0502 148 1	BEARING		1	1)
6	60 0502 148 2	BEARING		1	2)
7	60 0502 148 3	BEARING		4	1)
7	60 0502 148 4	BEARING		4	2)
1)	Remarks	Standard			
2)	Remarks	-0.254MM			

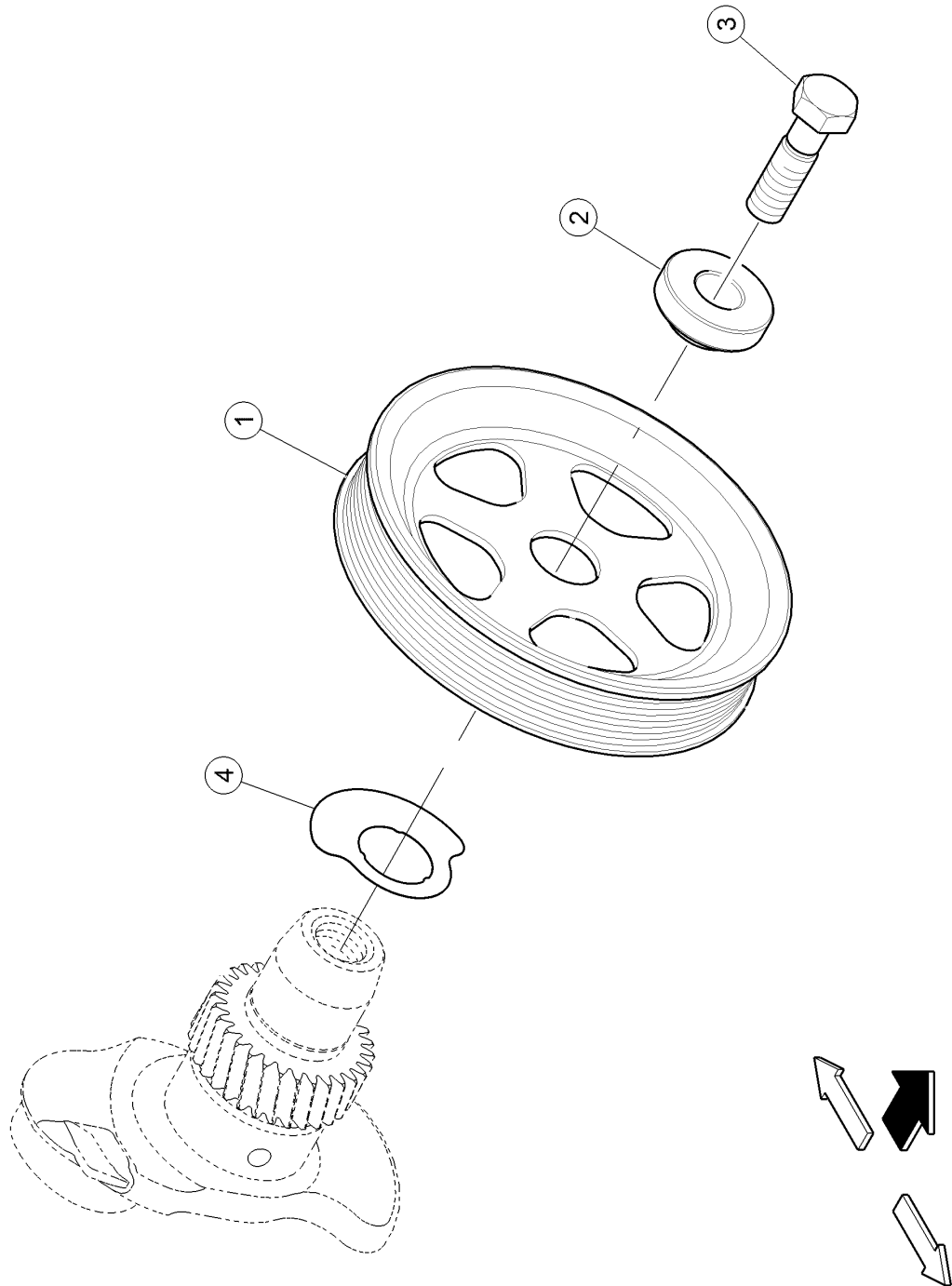

160 CRANKSHAFT PULLEY WHEEL

Pos.	Part No.	Description	Dimension	Quantity	Conditions
1	60 0503 052 4	CRANKSHAFT PULLEY		1	
2	60 0503 052 5	WASHER		1	
3	60 0502 866 8	SCREW	M20X70	1	
4	00 1171 430 0	FRICTION WASHER		1	

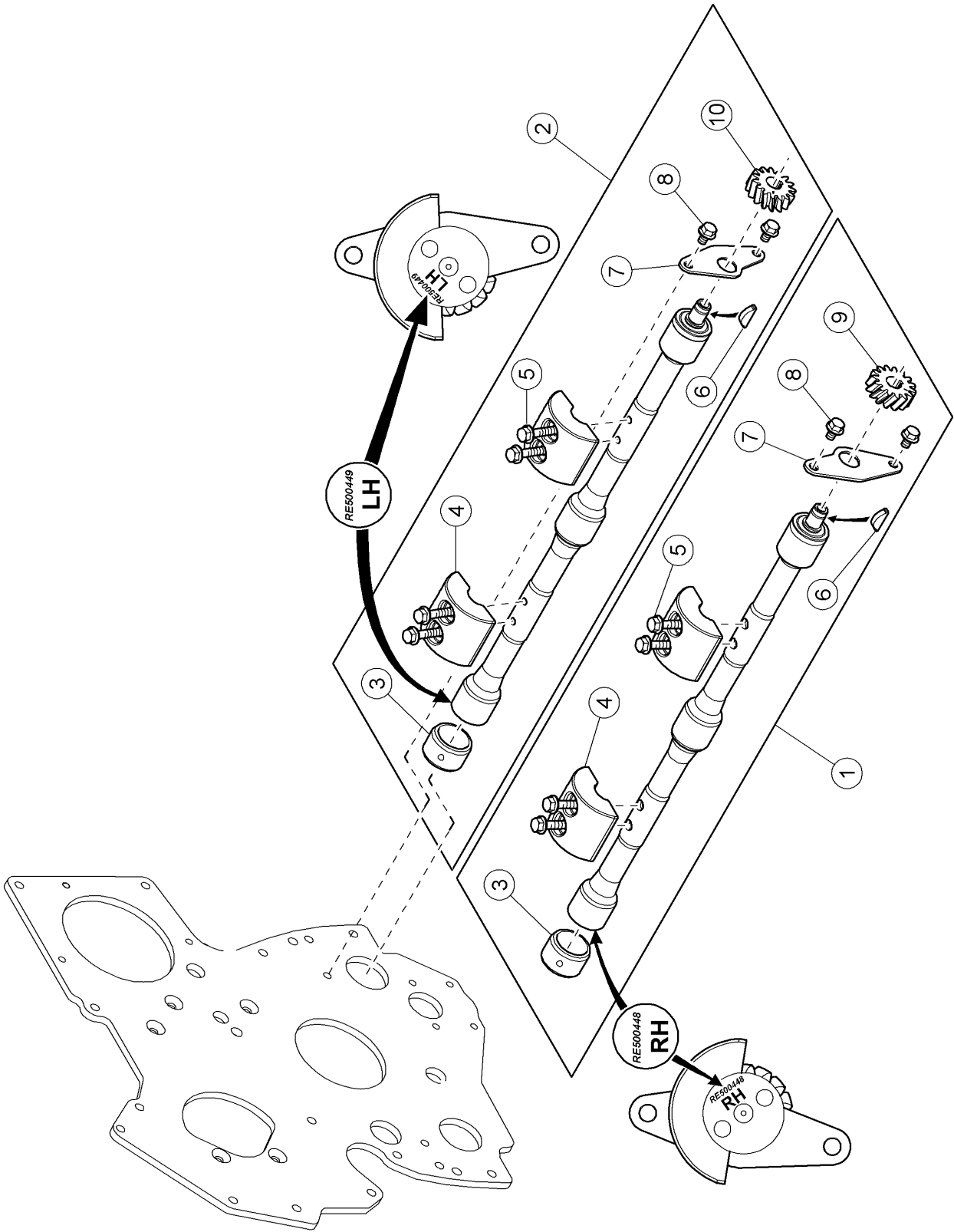

200 MASS BALANCING

Pos.	Part No.	Description	Dimension	Quantity	Conditions
1	60 0502 594 0	SHAFT		1	
2	60 0502 594 1	SHAFT		1	
3	60 0502 593 1	RING		6	
4	60 0502 594 6	FLYWEIGHT		4	
5	60 0502 594 7	SCREW	M8X40	8	
6	60 0502 151 0	KEY		2	
7	FA-NFP	NFP - CS		2	
8	60 0502 594 5	SCREW		4	
9	60 0502 594 2	WHEEL		1	
10	60 0502 594 3	WHEEL		1	

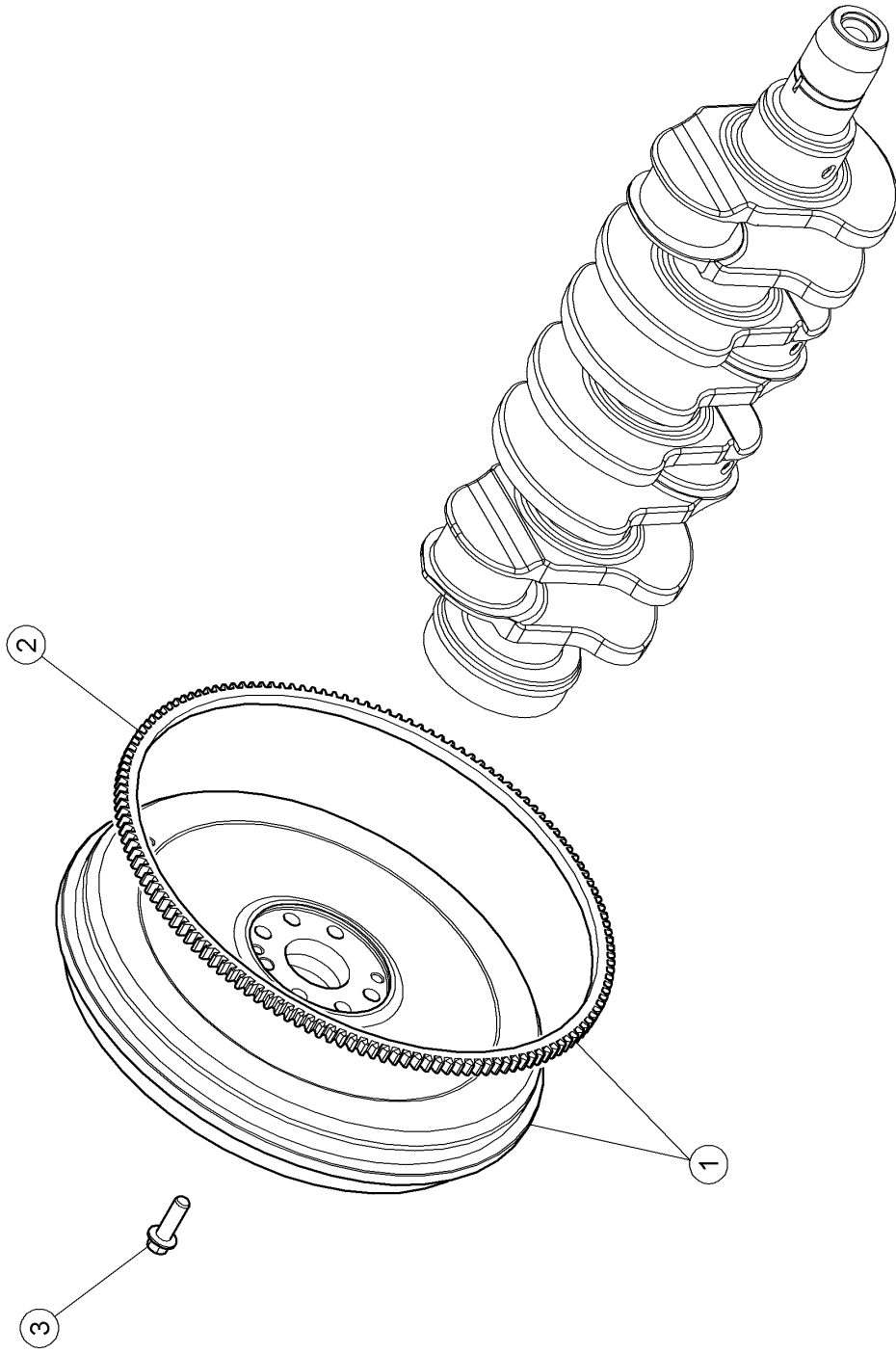

220 FLYWHEEL

Pos.	Part No.	Description	Dimension	Quantity	Conditions
1	00 1145 894 0	FLYWHEEL		1	
2	77 0004 531 5	TOOTHED RIM		1	
3	60 0502 625 8	SCREW	12 X 1,75 -37 - M12X40	6	

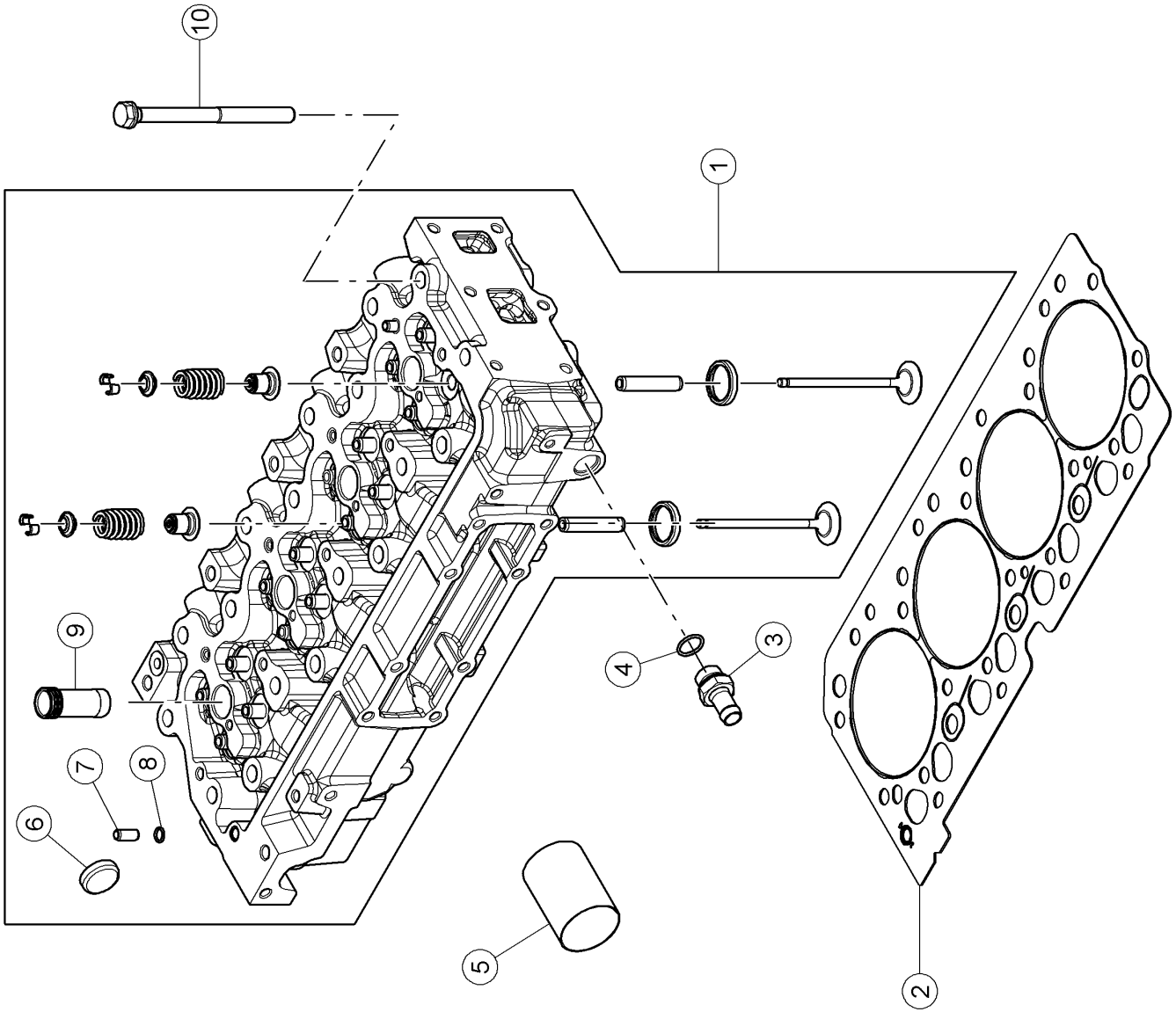

100 CYLINDER HEAD

Pos.	Part No.	Description	Dimension	Quantity	Conditions
1	00 1166 501 0	CYLINDER HEAD		1	
2	00 1145 358 0	CYLINDER HEAD GASKET		1	
3	00 1148 633 0	END PIECE		1	
4	60 0502 160 4	O-RING	19X2.4	1	
5	00 1145 915 0	SLEEVE		4	
6	60 0501 288 3	LOCK		5	
7	00 1145 916 0	RING		2	
8	77 0103 099 4	O-RING		2	
9	00 1142 367 0	LINER		4	
10	00 1145 917 0	SCREW		18	

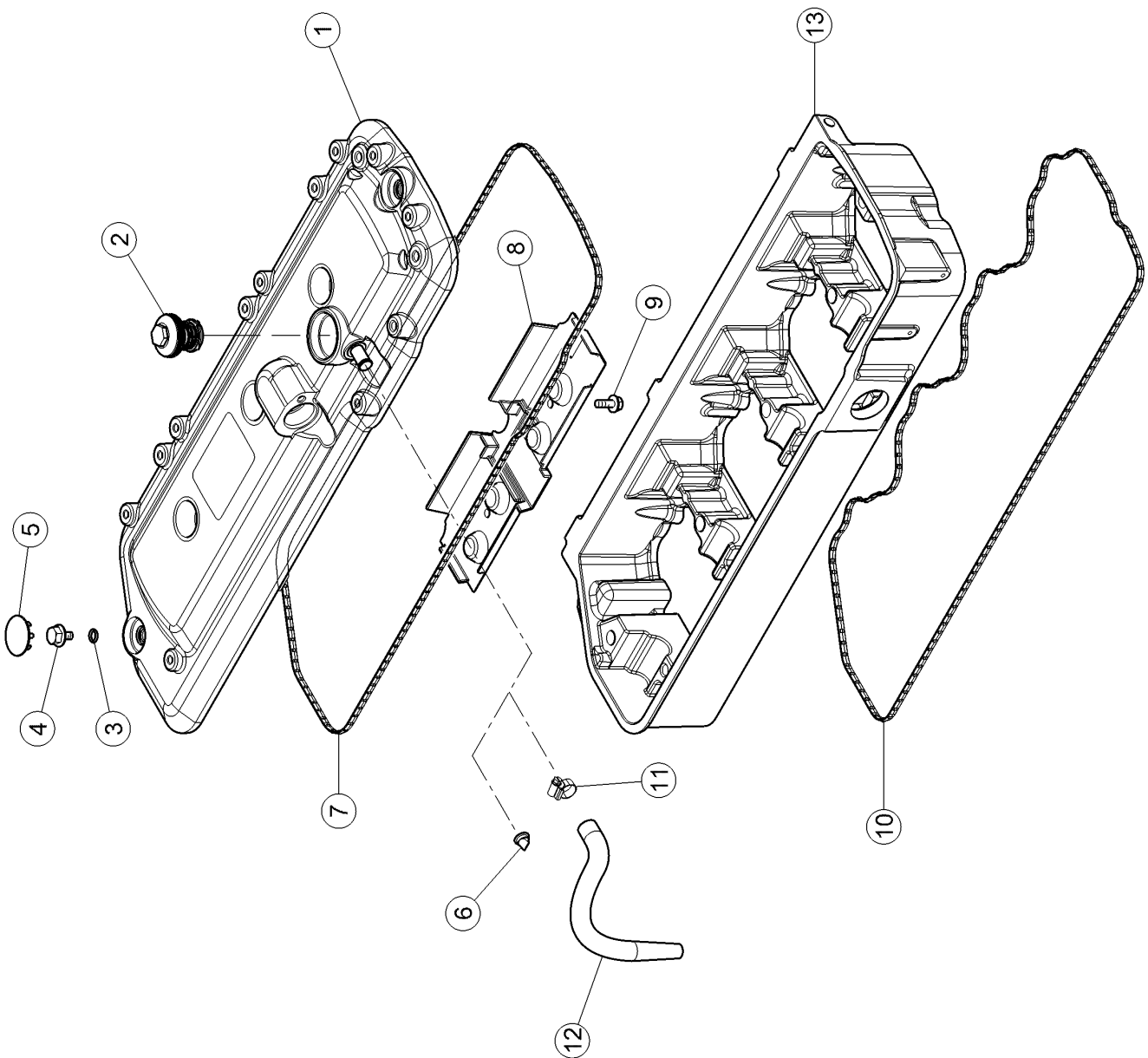

120 CYLINDER HEAD COVER

Pos.	Part No.	Description	Dimension	Quantity	Conditions
1	00 1153 352 0	ROCKER COVER		1	
2	00 1145 919 0	PLUG		1	
3	60 0502 134 7	O-RING	W.ERS. D. 0219 147.0	5	
4	00 1145 920 0	PLUG		5	
5	60 0502 134 4	PLUG		5	
6	00 1145 921 0	VALVE		1	
7	00 1135 008 0	GASKET		1	
8	00 1132 508 0	DEFLECTOR		1	
9	60 0502 144 8	SCREW	M6X16	2	
10	00 1148 710 0	SEALING RING		1	
11	60 0500 348 1	CLAMP	A 020-32X9 W2	1	
12	00 1153 353 0	PIPE		1	
13	00 1166 807 0	CASING		1	

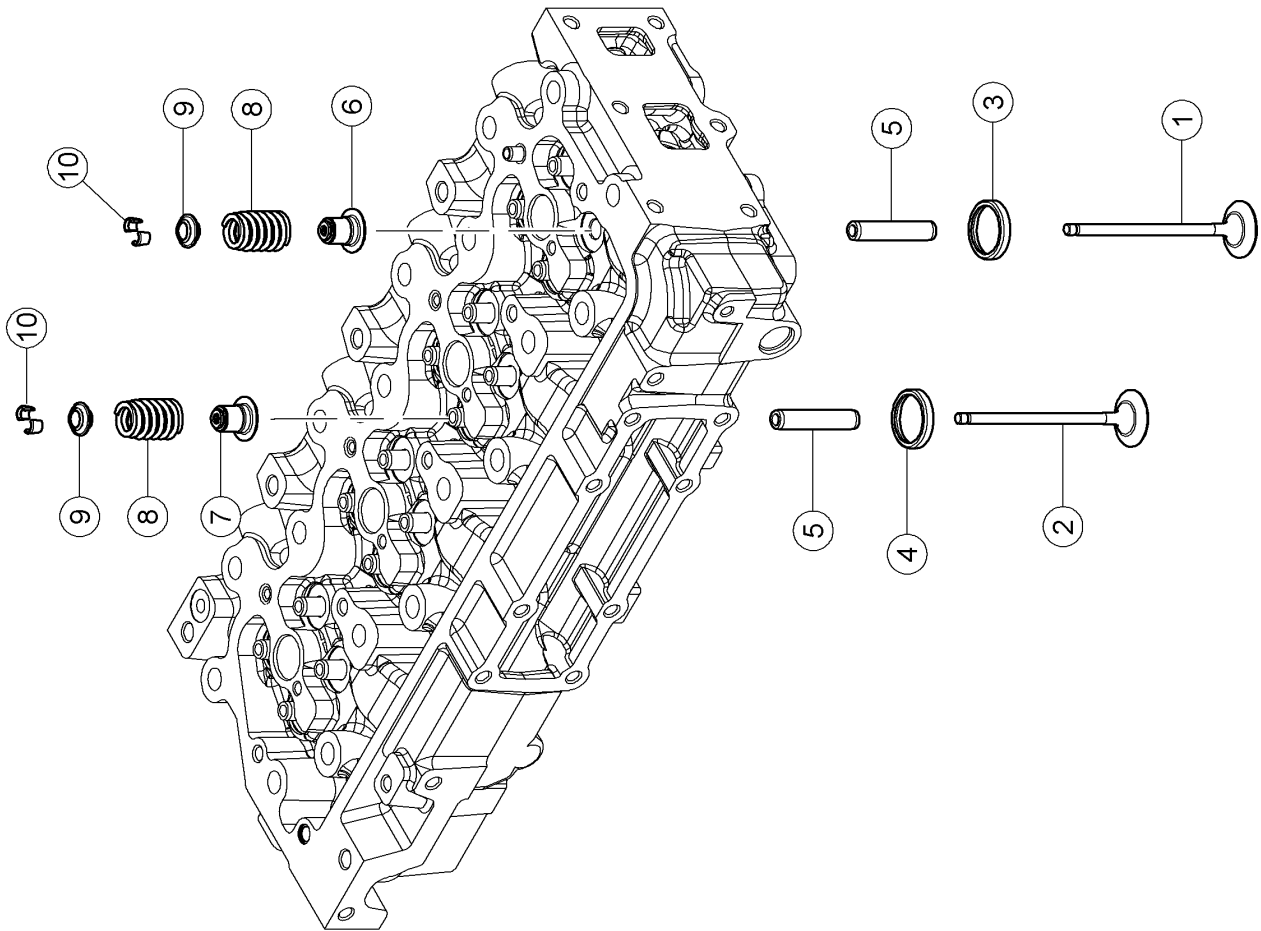

140 VALVES

Pos.	Part No.	Description	Dimension	Quantity	Conditions
1	00 1146 483 0	VALVE		8	1)
2	00 1145 923 0	VALVE		8	2)
3	00 1132 514 0	VALVE SEAT		8	1)
4	00 1132 513 0	VALVE SEAT		8	2)
5	00 1152 441 0	GUIDE		16	
6	00 1145 925 0	LIP SEAL		8	1)
7	00 1145 926 0	LIP SEAL	REPLACED W. 1169 343.0	8	2)
8	00 1145 927 0	SPRING		16	
9	00 1132 518 0	WASHER		16	
10	00 1148 631 0	HALF-CONE		32	

1) Remarks	Adm.
-------------------	------

2) Remarks	Echapt
-------------------	--------

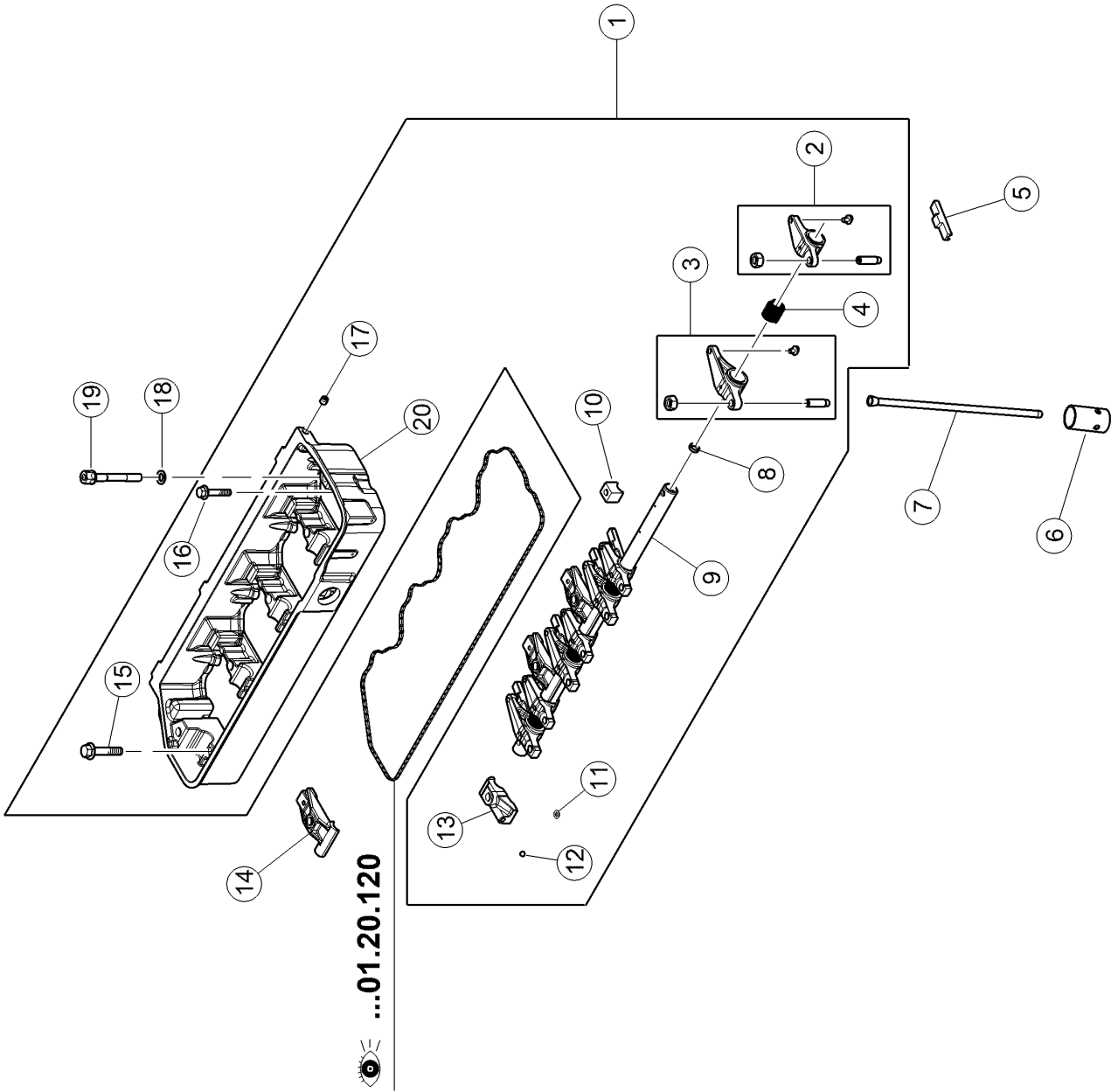



Suggest:

For more complete manuals. Please go to the home page.

<https://www.ebooklibonline.com>

If the above button click is invalid. Please download this document first, and then click the above link to download the complete manual.

Thank you so much for reading

160 ROCKER ARM

Pos.	Part No.	Description	Dimension	Quantity	Conditions
1	00 1145 928 0	CASING		1	
2	00 1165 757 0	ROCKER ARM		4	
3	00 1132 528 0	ROCKER ARM		4	
4	00 1132 530 0	SPRING		4	
5	00 1132 537 1	TIPPER		8	
6	00 1161 548 0	PUSHROD		8	
7	00 1166 976 0	ROD		8	
8	00 1132 534 0	PLUG		2	
9	00 1135 005 0	SHAFT		1	
10	00 1132 533 0	FLANGE		1	
11	00 1145 929 0	O-RING		1	
12	00 1145 930 0	BALL		1	
13	00 1132 524 0	FLANGE		1	
14	00 1145 931 0	FLANGE		3	
15	00 1145 932 0	SCREW	M10X50	1	
16	00 1145 933 0	SCREW		1	
17	00 1145 934 0	PLUG		2	
18	60 0501 278 2	WASHER		5	
19	00 1132 536 0	SCREW		5	
20	00 1166 807 0	CASING		1	

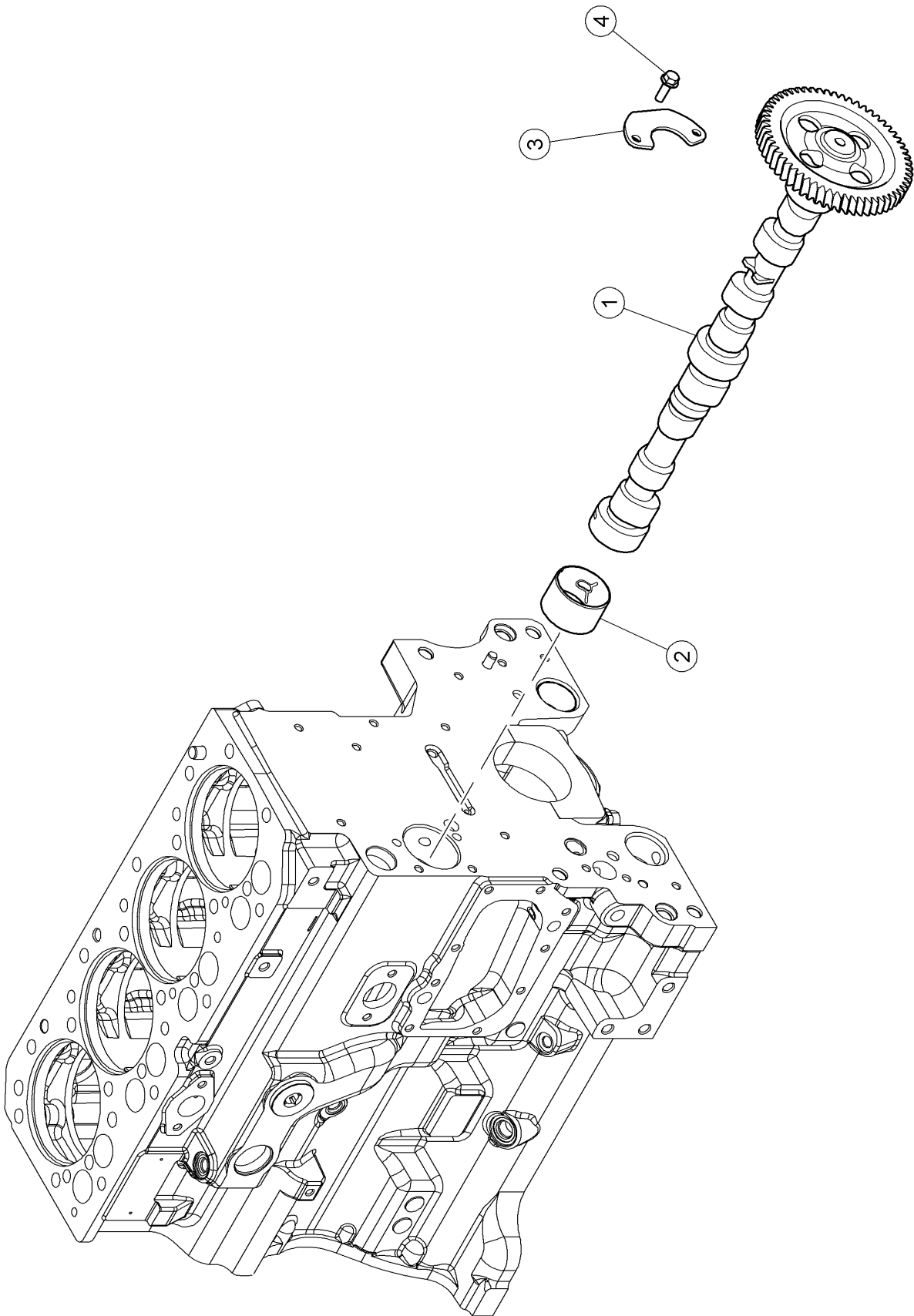

<https://www.ebooklibonline.com>

Hello dear friend!

Thank you very much for reading.

Enter the link into your browser.

The full manual is available for immediate download.

<https://www.ebooklibonline.com>