

**010 COMPLETE ENGINE**

| <b>Pos.</b> | <b>Part No.</b>         | <b>Description</b> | <b>Dimension</b> | <b>Quantity</b> | <b>Conditions</b> |
|-------------|-------------------------|--------------------|------------------|-----------------|-------------------|
| 1           | <b>77 0006 888 5</b>    | ENGINE             |                  | 1               | 1)                |
| 1           | <b>77 0006 888 6</b>    | ENGINE             |                  | 1               | 2)                |
| 1           | <b>00 1110 061 0</b>    | ENGINE             |                  | 1               | 3)                |
| <b>1)</b>   | <b>Homologationtype</b> |                    |                  | + 8252          |                   |
| <b>2)</b>   | <b>Homologationtype</b> |                    |                  | + 8262          |                   |
| <b>3)</b>   | <b>Homologationtype</b> |                    |                  | + 8272          |                   |

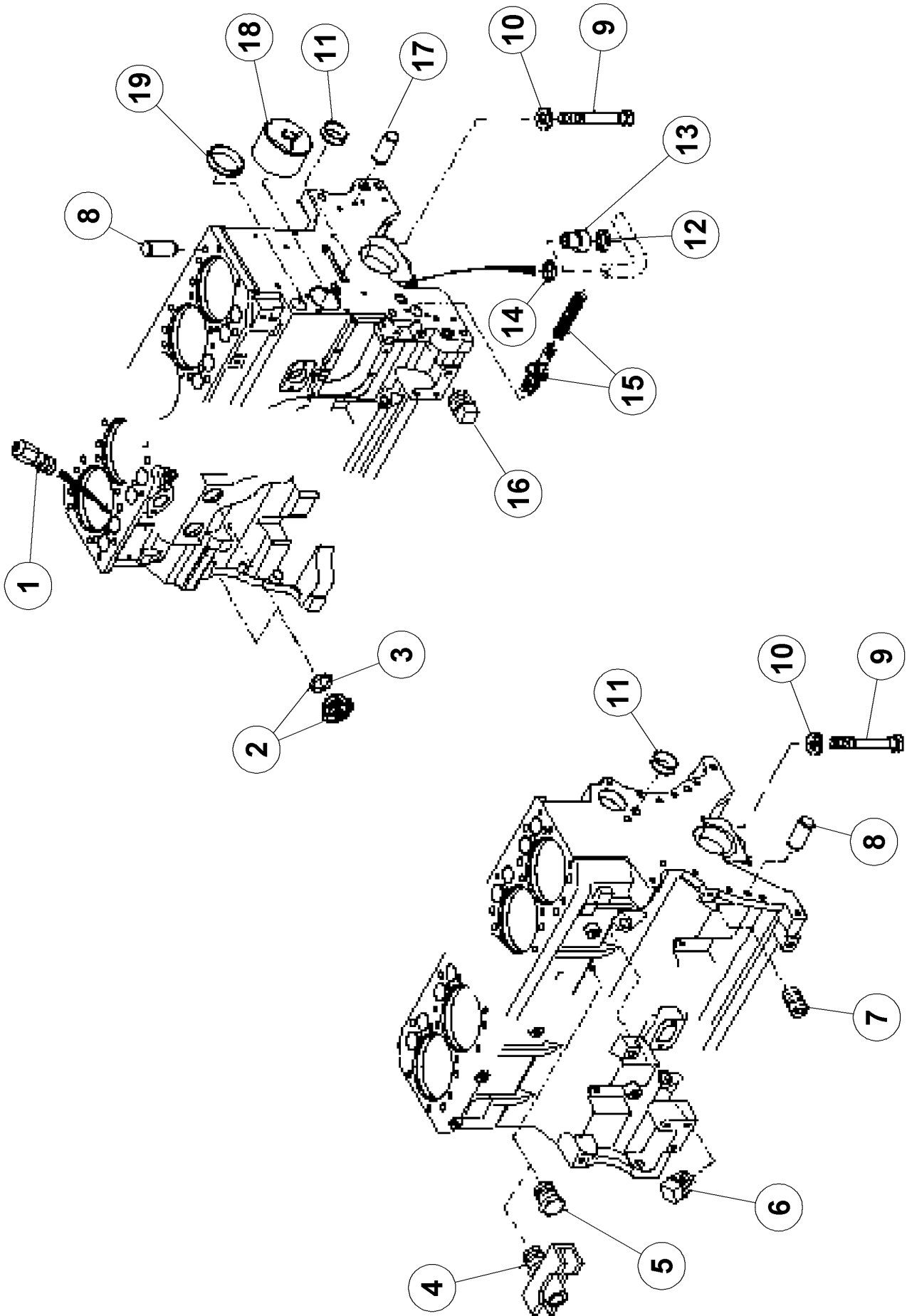

**<https://www.ebooklibonline.com>**

Hello dear friend!

Thank you very much for reading.

Enter the link into your browser.

The full manual is available for immediate download.

**<https://www.ebooklibonline.com>**

**100 CRANKCASE**

| <b>Pos.</b> | <b>Part No.</b>      | <b>Description</b> | <b>Dimension</b> | <b>Quantity</b> | <b>Conditions</b> |
|-------------|----------------------|--------------------|------------------|-----------------|-------------------|
| 1           | <b>60 0502 143 6</b> | SPRAY NOZZLE       |                  | 4               |                   |
| 2           | <b>60 0502 905 2</b> | PLUG               |                  | 2               |                   |
| 3           | <b>60 0502 339 4</b> | O-RING             |                  | 2               |                   |
| 4           | <b>60 0501 320 7</b> | VALVE              |                  | 1               |                   |
| 5           | <b>60 0502 665 3</b> | PLUG               |                  | 1               |                   |
| 6           | <b>60 0501 321 0</b> | PLUG               |                  | 1               |                   |
| 7           | <b>60 0502 144 0</b> | LOCK               |                  | 1               |                   |
| 8           | <b>60 0501 317 4</b> | CENTRING PIN       |                  | 4               |                   |
| 9           | <b>60 0501 320 6</b> | SCREW              |                  | 10              |                   |
| 10          | <b>60 0502 143 7</b> | WASHER             | 13X22X2,5        | 10              |                   |
| 11          | <b>60 0501 319 8</b> | BLANKING COVER     |                  | 2               |                   |
| 12          | <b>60 0501 334 1</b> | O-RING             |                  | 1               |                   |
| 13          | <b>60 0501 597 2</b> | BUSHING            |                  | 1               |                   |
| 14          | <b>60 0501 320 3</b> | O-RING             |                  | 1               |                   |
| 15          | <b>60 0501 402 9</b> | VALVE              |                  | 1               |                   |
| 16          | <b>60 0501 320 2</b> | LOCK               |                  | 1               |                   |
| 17          | <b>60 0501 319 6</b> | CENTRING PIN       |                  | 2               |                   |
| 18          | <b>60 0501 294 1</b> | BEARING            |                  | 1               |                   |
| 19          | <b>60 0502 143 9</b> | BLANKING COVER     |                  | 1               |                   |

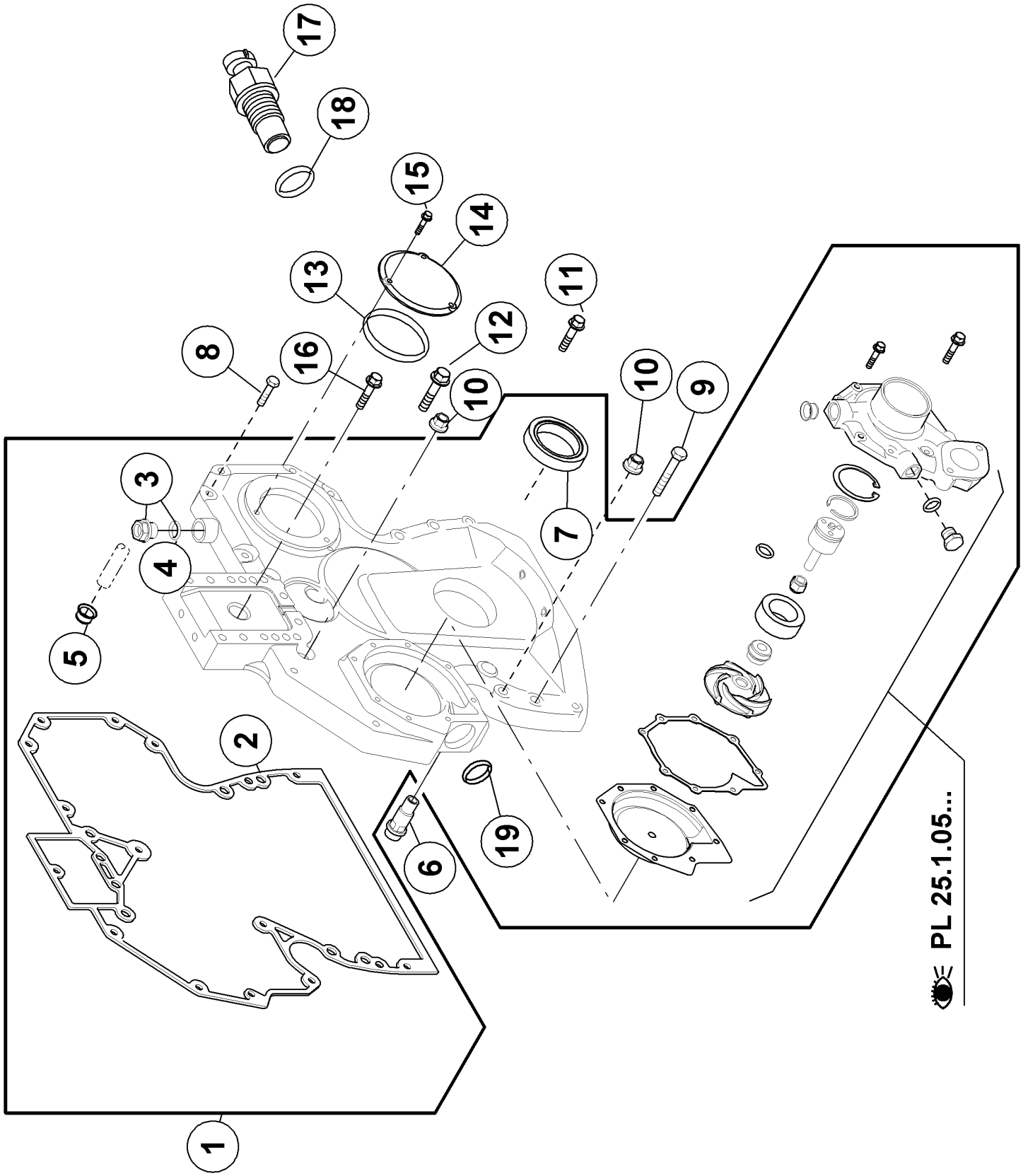

PL 25.1.05...

**120 TIMING CASE**

| Pos.      | Part No.             | Description  | Dimension                  | Quantity | Conditions |
|-----------|----------------------|--------------|----------------------------|----------|------------|
| 1         | <b>60 0502 869 0</b> | HOUSING      |                            | 1        |            |
| 2         | <b>60 0502 144 3</b> | GASKET       |                            | 1        |            |
| 3         | <b>60 0502 895 5</b> | SCREW PLUG   | F-M20X1,5                  | 1        |            |
| 4         | <b>77 0002 464 6</b> | O-RING       | 17X2-N ERS.D.<br>0238209.0 | 1        |            |
| 5         | <b>60 0502 163 0</b> | SEALING RING |                            | 1        |            |
| 6         | <b>60 0502 869 1</b> | VALVE        |                            | 1        |            |
| 7         | <b>60 0503 024 7</b> | SEALING RING |                            | 1        |            |
| 8         | <b>60 0502 144 5</b> | SCREW        | M8X45                      | 6        |            |
| 9         | <b>60 0502 145 8</b> | SCREW        |                            | 2        |            |
| 10        | <b>60 0502 144 9</b> | NUT          |                            | 6        |            |
| 11        | <b>60 0502 145 0</b> | SCREW        | M08X60                     | 1        |            |
| 12        | <b>60 0502 339 6</b> | SCREW        |                            | 1        |            |
| 13        | <b>60 0502 144 6</b> | O-RING       |                            | 1        |            |
| 14        | <b>60 0502 144 7</b> | COVER        |                            | 1        |            |
| 15        | <b>60 0502 144 8</b> | SCREW        | M6X16                      | 3        |            |
| 16        | <b>60 0502 144 4</b> | SCREW        | M8X35                      | 1        |            |
| 17        | <b>77 0007 199 7</b> | SENSOR       |                            | 1        | 1)         |
| 18        | <b>77 0002 464 6</b> | O-RING       | 17X2-N ERS.D.<br>0238209.0 | 1        |            |
| <b>1)</b> | <b>Remarks</b>       | vitesse mot. |                            |          |            |

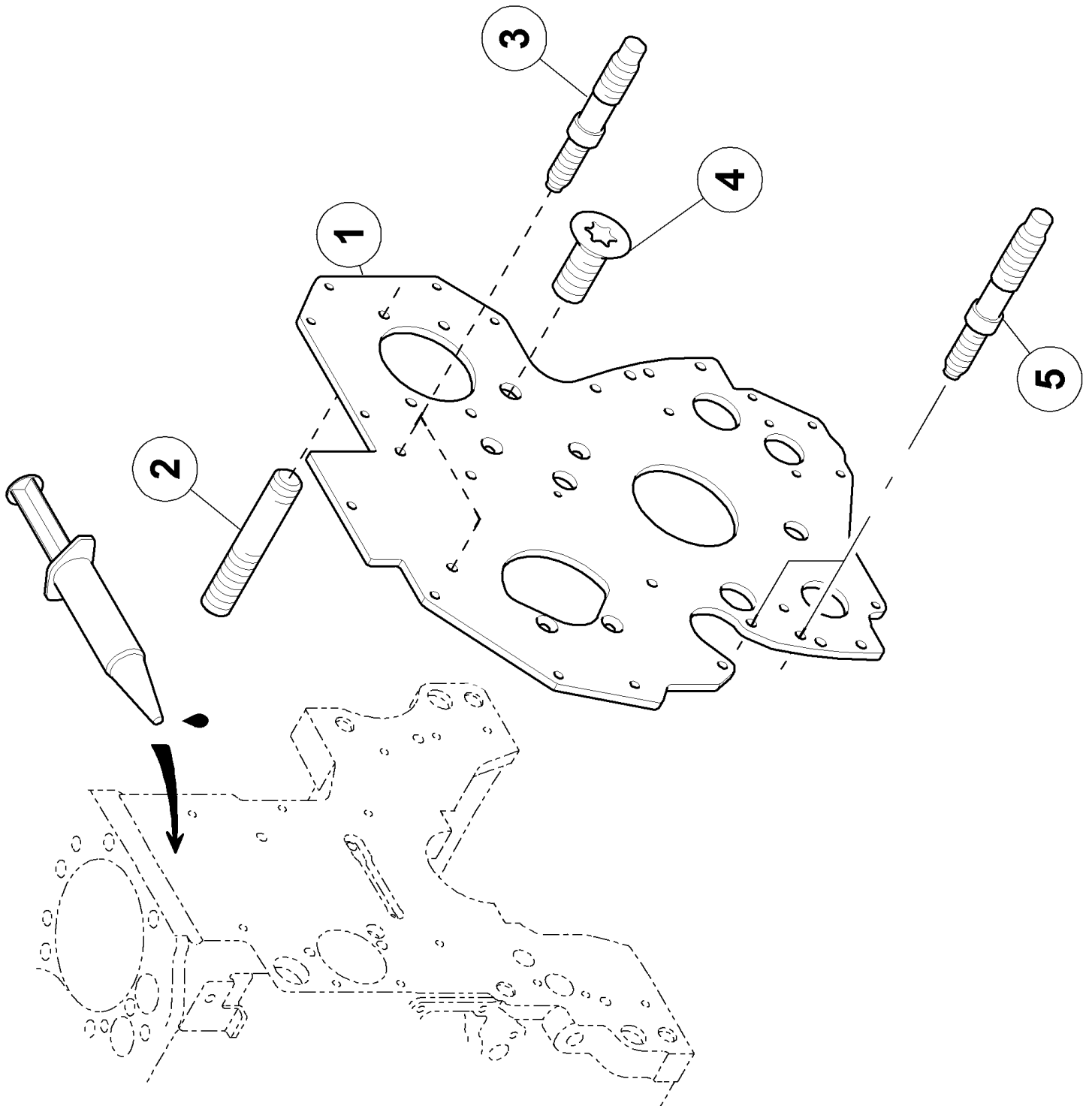

**120 TIMING CASE**

| <b>Pos.</b> | <b>Part No.</b>      | <b>Description</b> | <b>Dimension</b> | <b>Quantity</b> | <b>Conditions</b> |
|-------------|----------------------|--------------------|------------------|-----------------|-------------------|
| 1           | <b>60 0502 145 2</b> | PLATE              |                  | 1               |                   |
| 2           | <b>60 0502 145 5</b> | STUD BOLT          |                  | 3               |                   |
| 3           | <b>60 0502 339 8</b> | STUD BOLT          |                  | 2               |                   |
| 4           | <b>60 0502 339 7</b> | SCREW              |                  | 4               |                   |
| 5           | <b>60 0502 145 7</b> | STUD BOLT          |                  | 4               |                   |

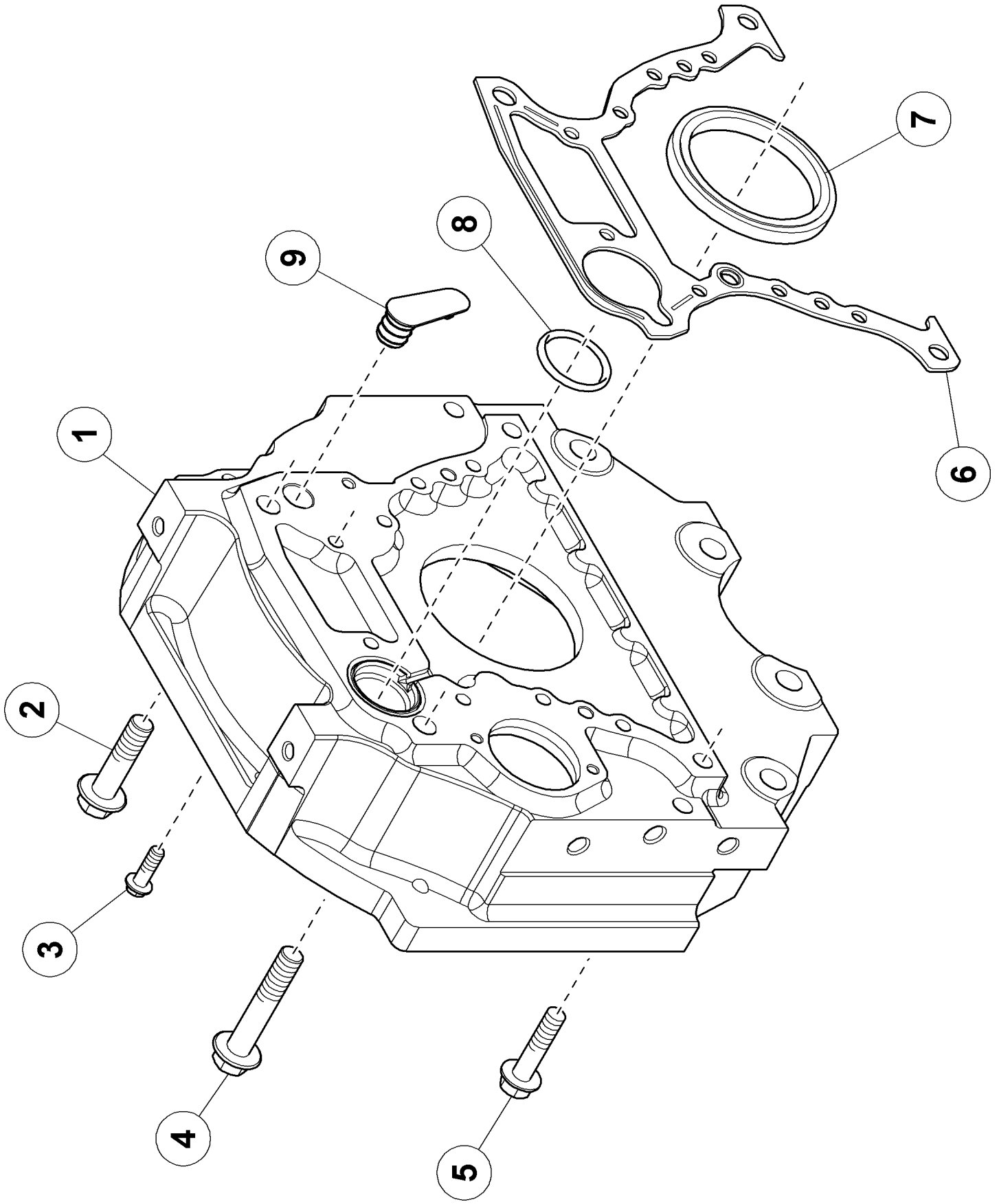

**140 FLYWHEEL HOUSING**

| Pos. | Part No.             | Description    | Dimension                 | Quantity | Conditions |
|------|----------------------|----------------|---------------------------|----------|------------|
| 1    | <b>77 0006 967 3</b> | CASING         |                           | 1        |            |
| 2    | <b>60 0502 146 5</b> | SCREW          |                           | 1        | 1)         |
| 3    | <b>60 0502 625 8</b> | SCREW          | 12 X 1,75 -37 -<br>M12X40 | 8        | 2)         |
| 4    | <b>60 0502 146 6</b> | SCREW          |                           | 1        | 3)         |
| 5    | <b>60 0502 146 8</b> | SCREW          |                           | 2        |            |
| 6    | <b>77 0005 577 1</b> | GASKET         |                           | 1        |            |
| 7    | <b>60 0501 279 0</b> | SHAFT SEAL     | 118X146X15                | 1        | 4)         |
| 8    | <b>60 0501 604 9</b> | O-RING         |                           | 1        |            |
| 9    | <b>60 0502 146 2</b> | BLANKING COVER |                           | 1        |            |

|           |                |             |
|-----------|----------------|-------------|
| <b>1)</b> | <b>Remarks</b> | M20X250-80  |
| <b>2)</b> | <b>Remarks</b> | M12X175-38  |
| <b>3)</b> | <b>Remarks</b> | M20X250-110 |
| <b>4)</b> | <b>Remarks</b> | 118X146X15  |

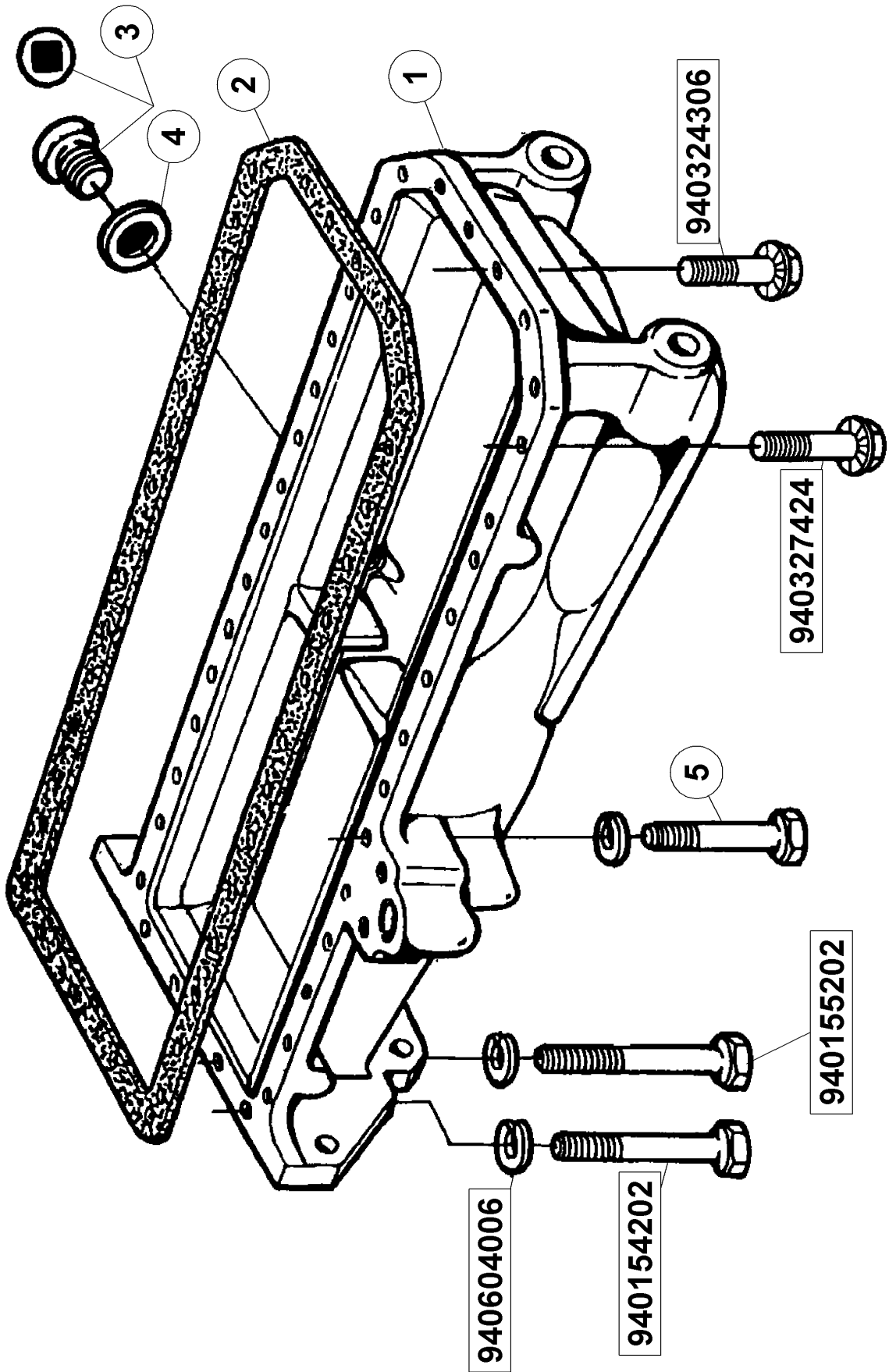

**160 OIL PAN**

| <b>Pos.</b>   | <b>Part No.</b>      | <b>Description</b> | <b>Dimension</b>        | <b>Quantity</b> | <b>Conditions</b> |
|---------------|----------------------|--------------------|-------------------------|-----------------|-------------------|
| 1             | <b>60 0502 666 5</b> | OIL SUMP           |                         | 1               |                   |
| 2             | <b>60 0502 666 6</b> | GASKET             |                         | 1               |                   |
| 3             | <b>60 0501 279 3</b> | LOCK               |                         | 1               |                   |
| 4             | <b>60 0501 211 0</b> | GASKET             |                         | 1               |                   |
| 5             | <b>60 0502 147 1</b> | SCREW              |                         | 2               |                   |
| 94015<br>4202 | <b>77 0310 108 5</b> | HEXAGON HEAD BOLT  | M10X140-32              | 2               |                   |
| 94015<br>5202 | <b>77 0102 451 6</b> | SCREW              |                         | 2               |                   |
| 94032<br>4306 | <b>77 0101 759 2</b> | SCREW              | M08X35 VERBUS RIPP      | 6               |                   |
| 94032<br>7424 | <b>77 0001 434 0</b> | SCREW              | M10X35 - VERBUS<br>RIPP | 24              |                   |
| 94060<br>4006 | <b>77 0305 501 3</b> | WASHER             | 10                      | 6               |                   |

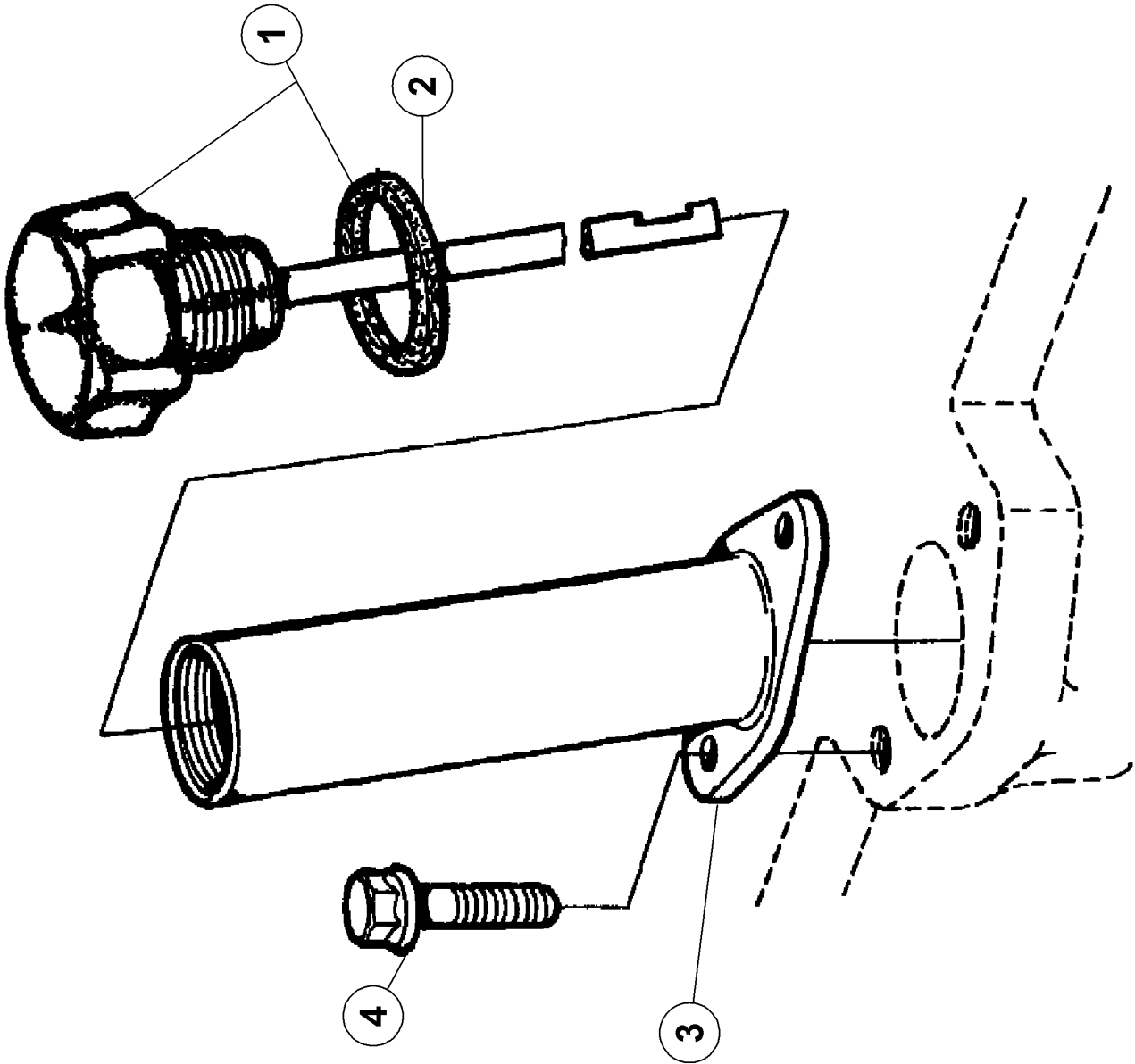

**160 OIL PAN**

| <b>Pos.</b> | <b>Part No.</b>      | <b>Description</b> | <b>Dimension</b> | <b>Quantity</b> | <b>Conditions</b> |
|-------------|----------------------|--------------------|------------------|-----------------|-------------------|
| 1           | <b>60 0501 279 5</b> | GAUGE              |                  | 1               |                   |
| 2           | <b>60 0501 334 6</b> | O-RING             |                  | 1               |                   |
| 3           | <b>60 0501 279 4</b> | TUBE               |                  | 1               |                   |
| 4           | <b>60 0502 145 6</b> | SCREW              | M8X25            | 2               | 1)                |
| <b>1)</b>   | <b>Remarks</b>       |                    | M8x25            |                 |                   |

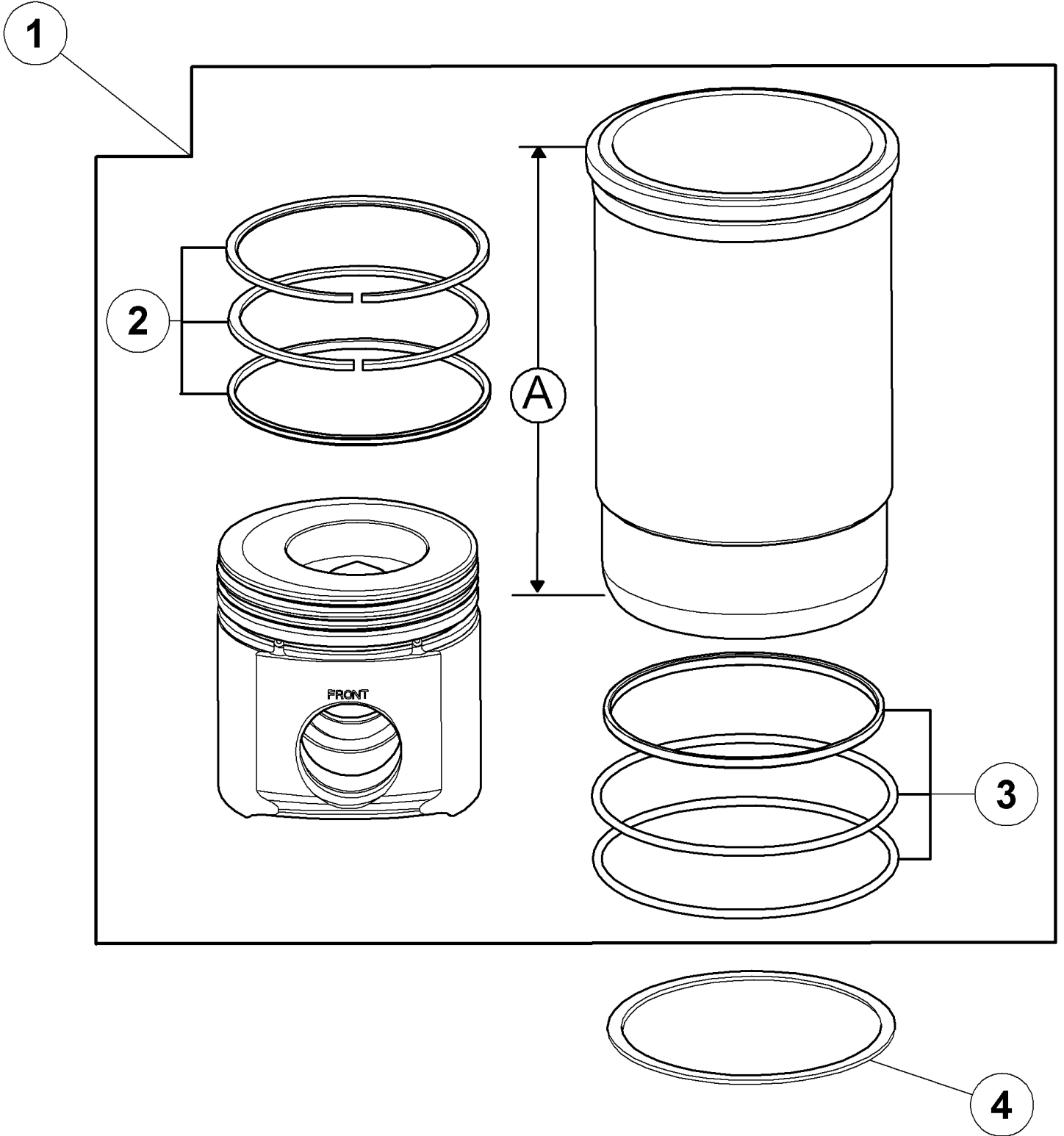

**100 CYLINDER LINER, PISTON**

| <b>Pos.</b> | <b>Part No.</b>      | <b>Description</b>  | <b>Dimension</b> | <b>Quantity</b> | <b>Conditions</b> |
|-------------|----------------------|---------------------|------------------|-----------------|-------------------|
| 1           | <b>60 0502 869 4</b> | PISTON-LINER        |                  | 6               |                   |
| 2           | <b>60 0502 869 5</b> | SET OF PISTON RINGS |                  | 6               |                   |
| 3           | <b>60 0501 280 9</b> | SEALING RING SET    |                  | 6               |                   |
| 4           | <b>60 0501 281 5</b> | ADJUSTING DISC      |                  | 6               | 1)                |
| 4           | <b>60 0501 281 6</b> | ADJUSTING DISC      |                  | 6               | 2)                |
| <b>1)</b>   | <b>Remarks</b>       |                     | ép.0.05          |                 |                   |
| <b>2)</b>   | <b>Remarks</b>       |                     | ép.0.10          |                 |                   |

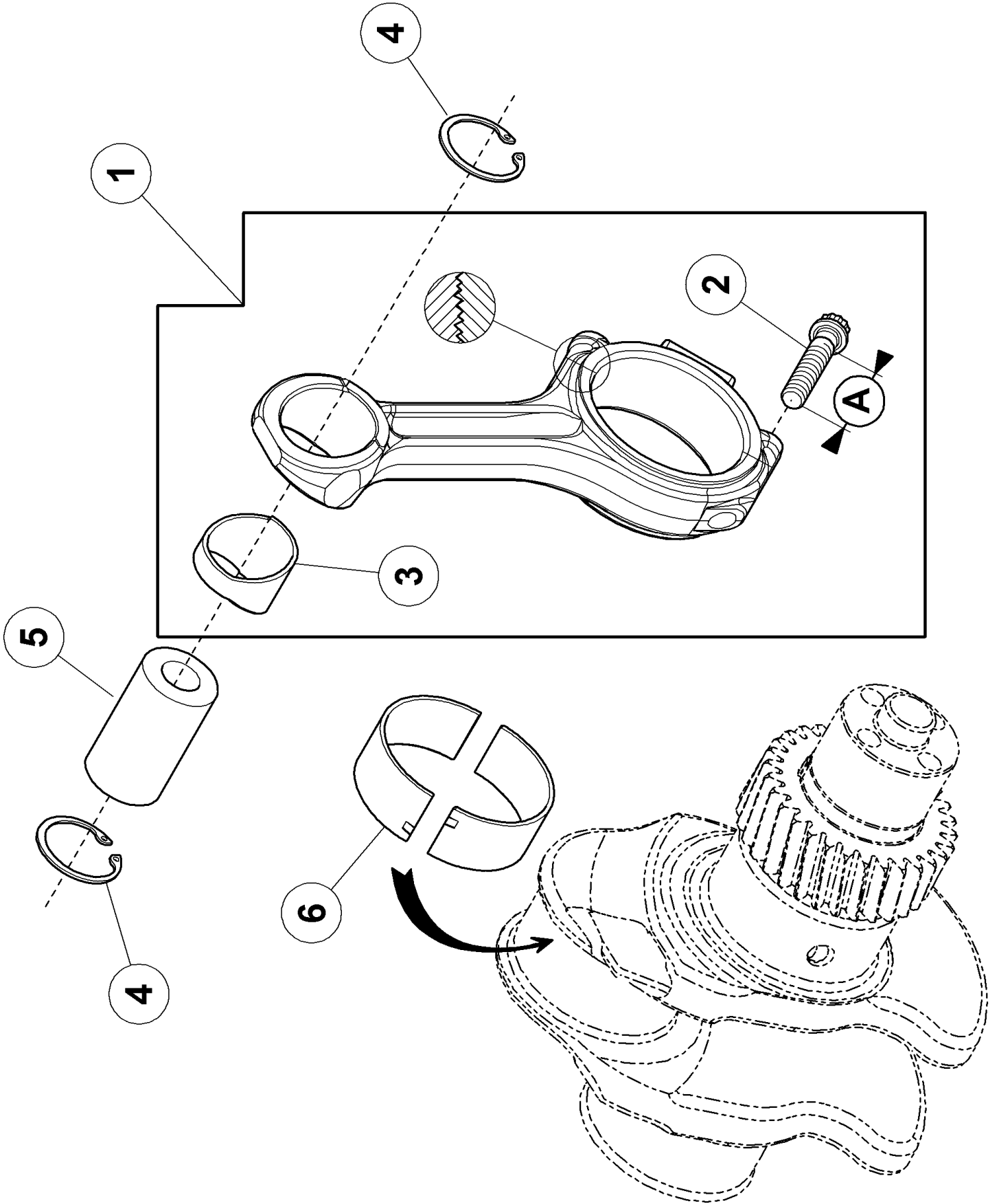

**120 CONNECTING ROD, CONNECTING ROD BEARINGS**

| <b>Pos.</b> | <b>Part No.</b>      | <b>Description</b> | <b>Dimension</b>          | <b>Quantity</b> | <b>Conditions</b> |
|-------------|----------------------|--------------------|---------------------------|-----------------|-------------------|
| 1           | <b>60 0502 453 6</b> | CONNECTING ROD     |                           | 6               |                   |
| 2           | <b>60 0502 453 7</b> | SCREW              | 12 PTS M12 X 1,25 -<br>61 | 12              |                   |
| 3           | <b>60 0502 147 6</b> | RING               |                           | 6               |                   |
| 4           | <b>60 0501 281 4</b> | INNER CIRCLIP      |                           | 12              |                   |
| 5           | <b>60 0502 147 7</b> | AXLE               |                           | 6               |                   |
| 6           | <b>60 0502 147 8</b> | BEARING            |                           | 6               |                   |
| 6           | <b>60 0502 147 9</b> | BEARING            |                           | 6               | 1)                |
| <b>1)</b>   | <b>Remarks</b>       |                    | -0,254mm                  |                 |                   |

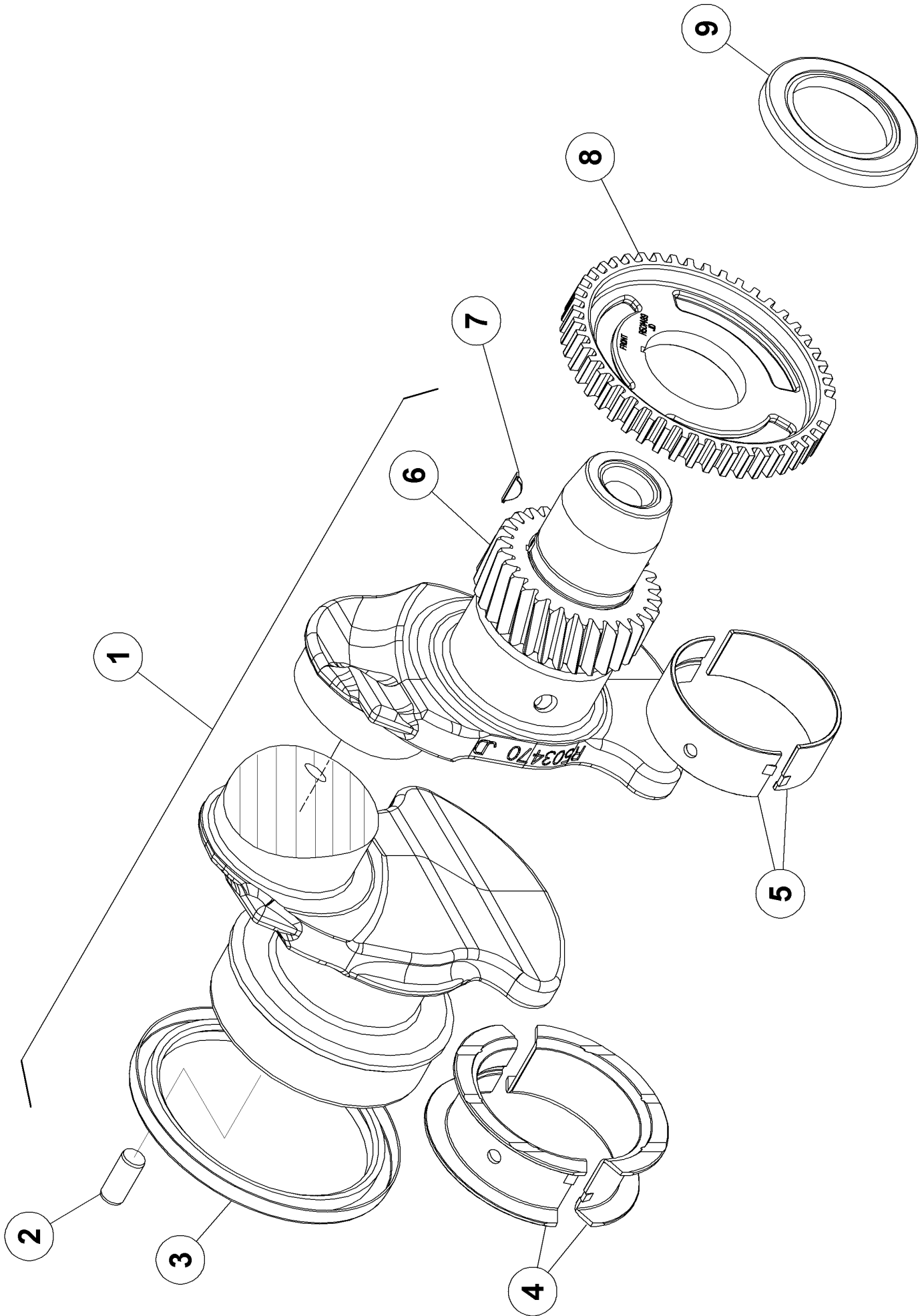

**140 CRANKSHAFT**

| <b>Pos.</b> | <b>Part No.</b>      | <b>Description</b> | <b>Dimension</b> | <b>Quantity</b> | <b>Conditions</b> |
|-------------|----------------------|--------------------|------------------|-----------------|-------------------|
| 1           | <b>60 0502 869 6</b> | CRANKSHAFT         |                  | 1               |                   |
| 2           | <b>60 0501 317 4</b> | CENTRING PIN       |                  | 1               |                   |
| 3           | <b>60 0501 279 0</b> | SHAFT SEAL         | 118X146X15       | 1               |                   |
| 4           | <b>60 0502 148 1</b> | BEARING            |                  | 1               |                   |
| 4           | <b>60 0502 148 2</b> | BEARING            |                  | 1               | 1)                |
| 5           | <b>60 0502 148 3</b> | BEARING            |                  | 6               |                   |
| 5           | <b>60 0502 148 4</b> | BEARING            |                  | 6               | 1)                |
| 6           | <b>60 0502 148 5</b> | WHEEL              |                  | 1               | 2)                |
| 7           | <b>60 0502 869 7</b> | KEY                |                  | 1               |                   |
| 8           | <b>60 0502 869 8</b> | WHEEL              |                  | 1               |                   |
| 9           | <b>60 0503 024 7</b> | SEALING RING       |                  | 1               |                   |
| <b>1)</b>   | <b>Remarks</b>       |                    |                  |                 | -0.254mm          |
| <b>2)</b>   | <b>Remarks</b>       |                    |                  |                 | 30 dts.           |

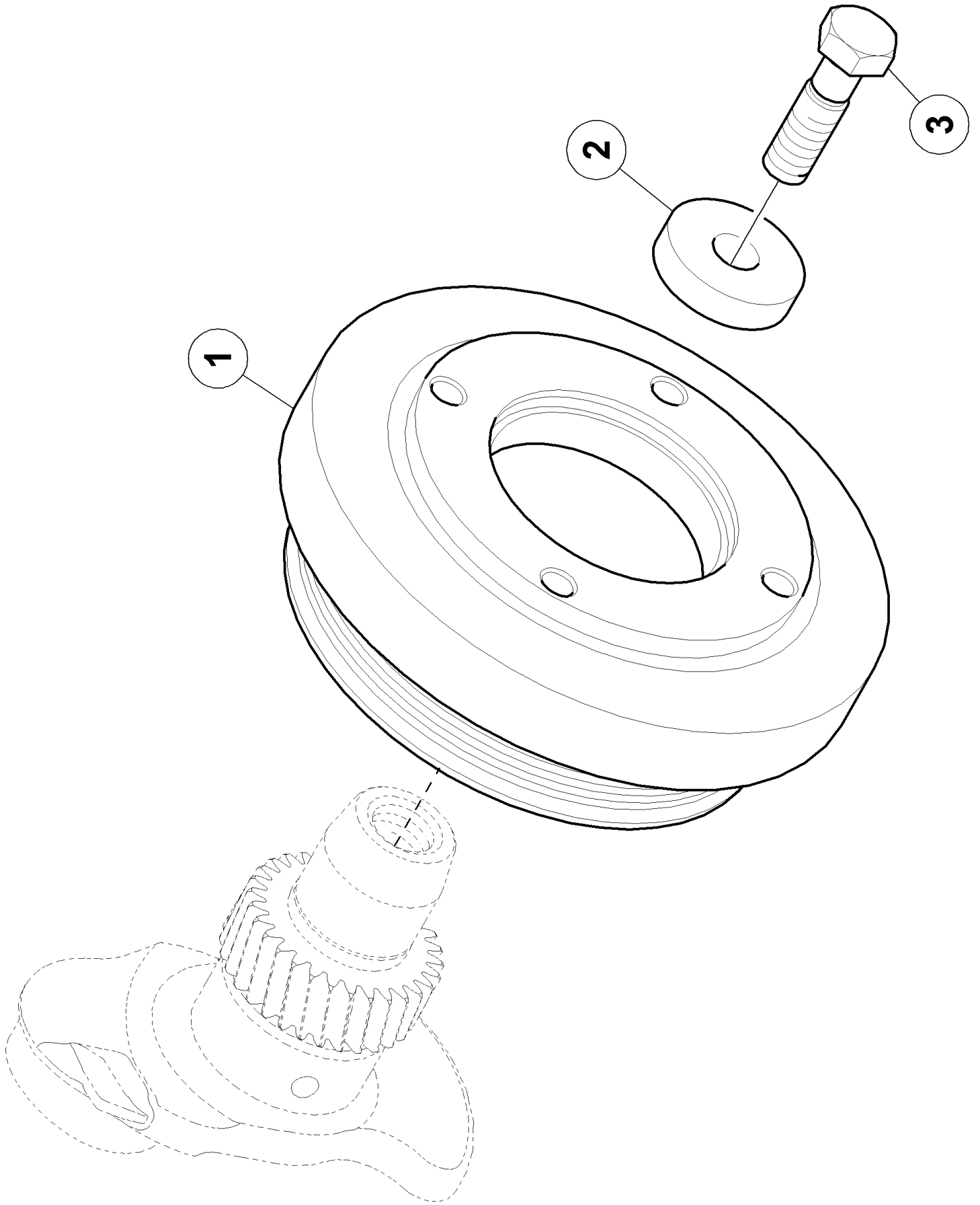

**161 CRANKSHAFT PULLEY WHEEL**

| <b>Pos.</b> | <b>Part No.</b>      | <b>Description</b>   | <b>Dimension</b> | <b>Quantity</b> | <b>Conditions</b> |
|-------------|----------------------|----------------------|------------------|-----------------|-------------------|
| 1           | <b>77 0006 623 2</b> | ANTI-VIBRATION WHEEL |                  | 1               |                   |
| 2           | <b>60 0503 045 1</b> | SPACER               |                  | 1               |                   |
| 3           | <b>60 0502 866 8</b> | SCREW                | M20X70           | 1               |                   |

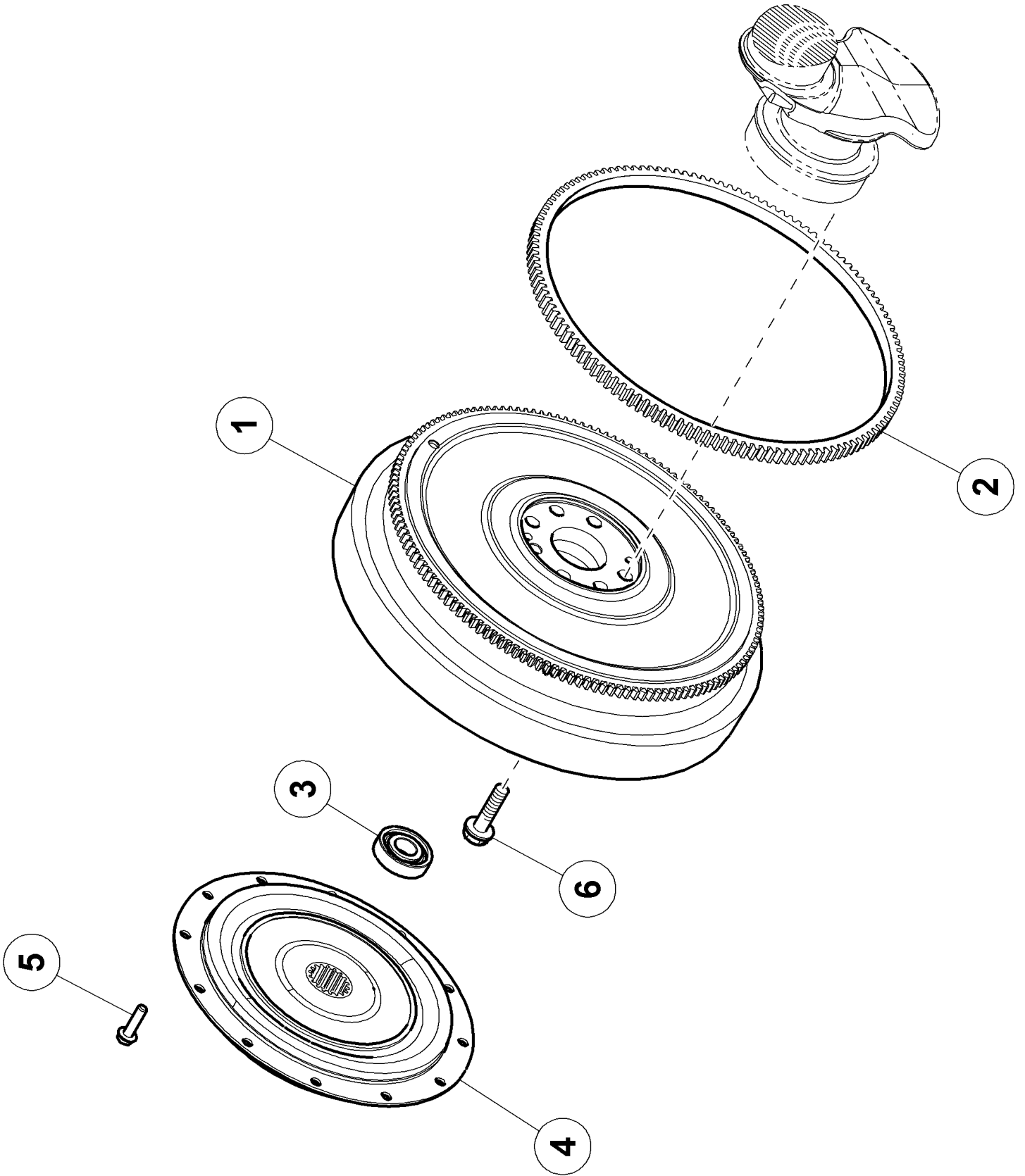

**220 FLYWHEEL**

| Pos. | Part No.             | Description       | Dimension                 | Quantity | Conditions |
|------|----------------------|-------------------|---------------------------|----------|------------|
| 1    | <b>77 0007 132 9</b> | FLYWHEEL          |                           | 1        |            |
| 2    | <b>77 0004 728 5</b> | TOOTHED RIM       |                           | 1        |            |
| 3    | <b>77 0103 068 6</b> | BEARING-1 BALL    | 6305-2RS                  | 1        | 1)         |
| 4    | <b>77 0006 716 1</b> | TORSION DAMPER    |                           | 1        | 2)         |
| 4    | <b>00 1111 394 0</b> | HUB               |                           | 1        | 3)         |
| 5    | <b>77 0005 997 8</b> | HEXAGON HEAD BOLT | M10X40                    | 8        | 4)         |
| 6    | <b>60 0502 625 8</b> | SCREW             | 12 X 1,75 -37 -<br>M12X40 | 6        | 5)         |

|           |                         |             |
|-----------|-------------------------|-------------|
| <b>1)</b> | <b>Remarks</b>          | 25X62X17    |
| <b>2)</b> | <b>Homologationtype</b> | + 8252      |
| <b>3)</b> | <b>Homologationtype</b> | - 8252      |
| <b>4)</b> | <b>Remarks</b>          | HM10X150-40 |
| <b>5)</b> | <b>Remarks</b>          | HM12X175-38 |

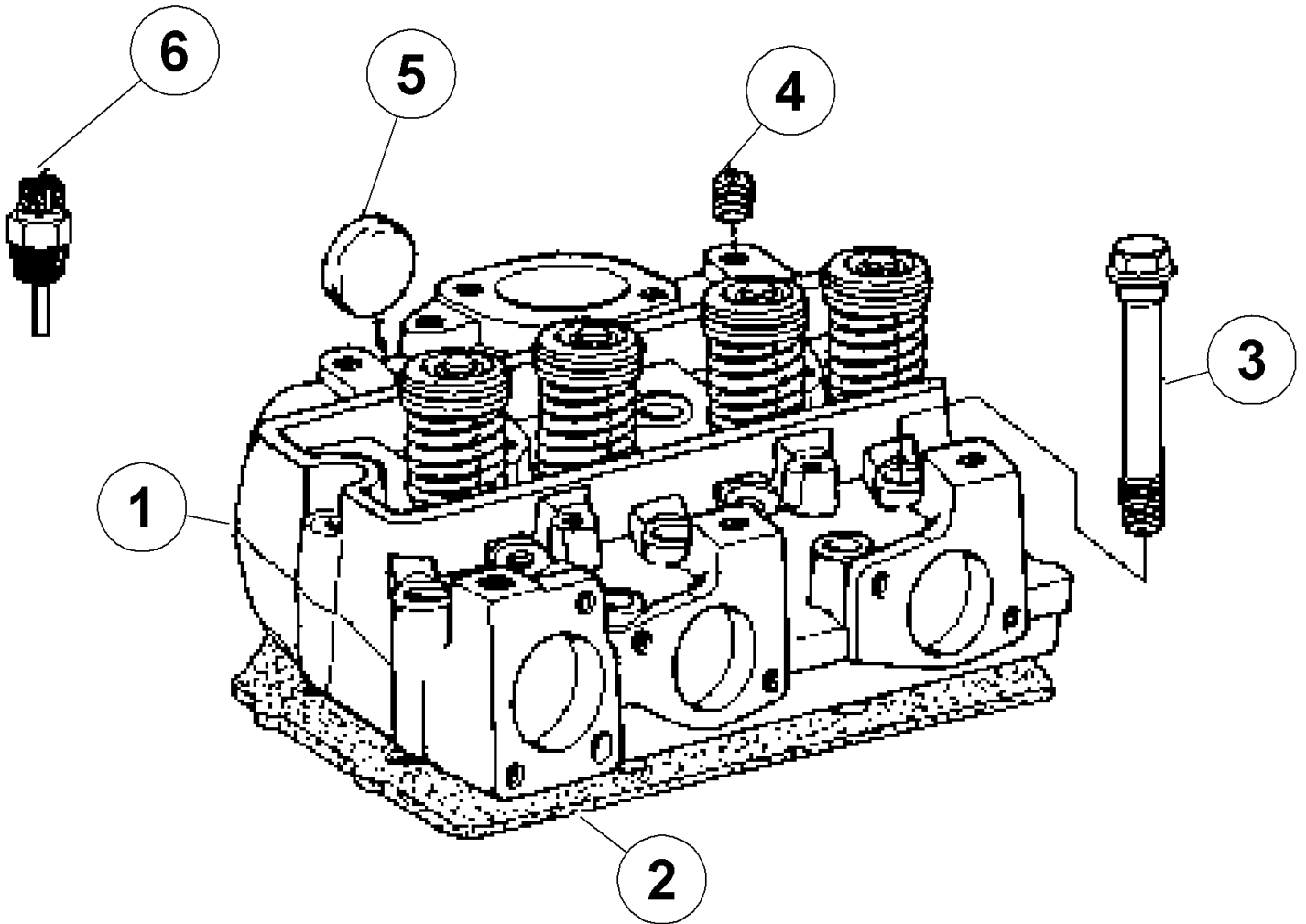

**100 CYLINDER HEAD**

| <b>Pos.</b> | <b>Part No.</b>      | <b>Description</b>   | <b>Dimension</b> | <b>Quantity</b> | <b>Conditions</b> |
|-------------|----------------------|----------------------|------------------|-----------------|-------------------|
| 1           | <b>60 0502 149 0</b> | CYLINDER HEAD        |                  | 1               |                   |
| 2           | <b>60 0502 149 1</b> | CYLINDER HEAD GASKET |                  | 1               |                   |
| 3           | <b>60 0501 288 6</b> | SCREW                |                  | 26              |                   |
| 4           | <b>60 0502 144 0</b> | LOCK                 |                  | 1               |                   |
| 5           | <b>60 0501 288 3</b> | LOCK                 |                  | 1               | 1)                |
| 5           | <b>60 0502 149 2</b> | PLUG                 |                  | 3               | 2)                |
| 6           | <b>60 0501 344 2</b> | SENDER UNIT          |                  | 1               |                   |

---

|                   |         |
|-------------------|---------|
| <b>1) Remarks</b> | DI.32,6 |
| <b>2) Remarks</b> | DI.43,4 |

---

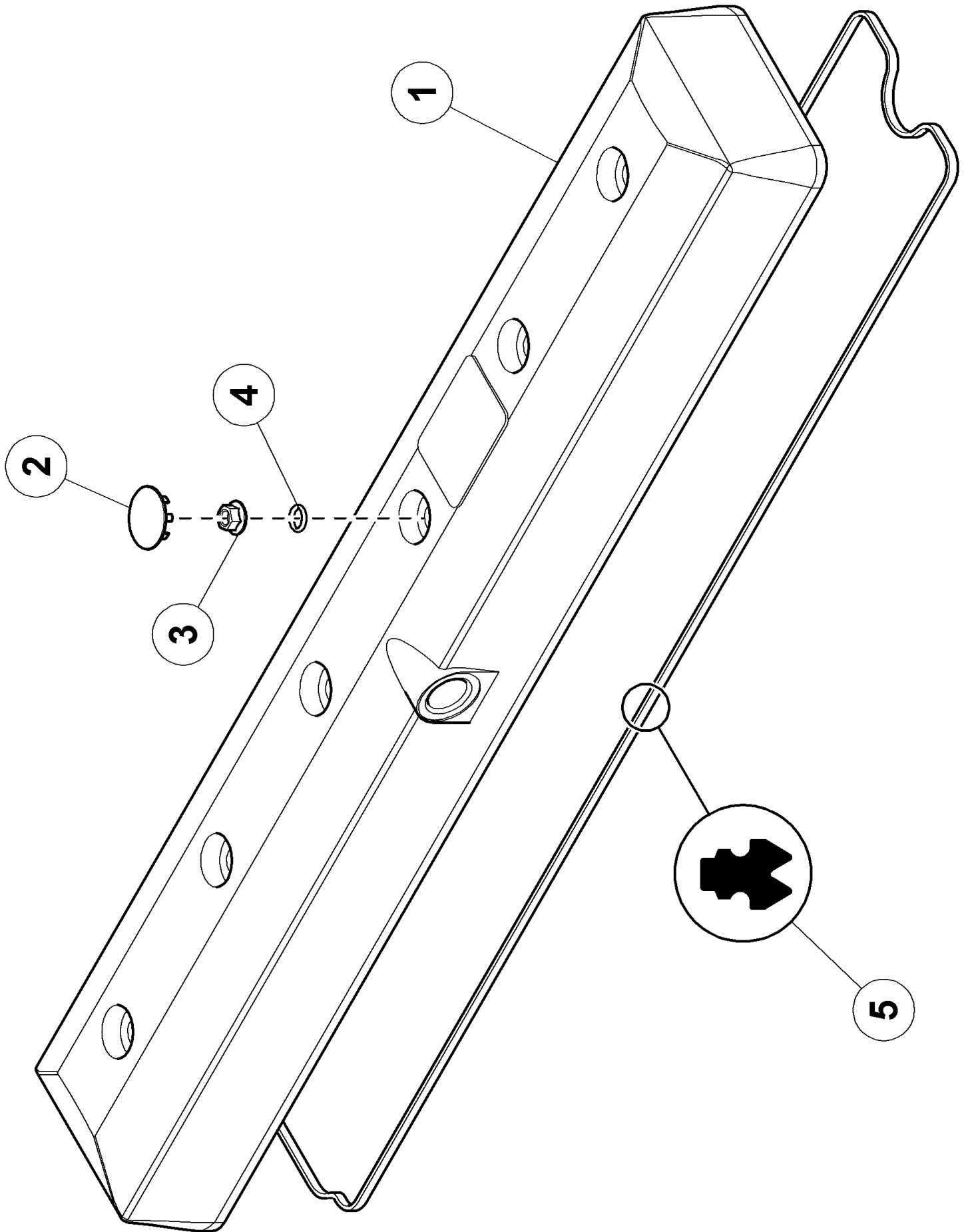

**120 CYLINDER HEAD COVER**

| <b>Pos.</b> | <b>Part No.</b>          | <b>Description</b> | <b>Dimension</b>     | <b>Quantity</b> | <b>Conditions</b> |
|-------------|--------------------------|--------------------|----------------------|-----------------|-------------------|
| 1           | <b>FA-CONSIGN<br/>ES</b> | Consignes - CS     |                      | 1               |                   |
| 2           | <b>60 0502 134 4</b>     | PLUG               |                      | 6               |                   |
| 3           | <b>60 0502 149 4</b>     | FLANGE NUT         |                      | 6               |                   |
| 4           | <b>60 0502 134 7</b>     | O-RING             | W.ERS. D. 0219 147.0 | 6               |                   |
| 5           | <b>60 0502 134 5</b>     | SEALING RING       |                      | 1               |                   |

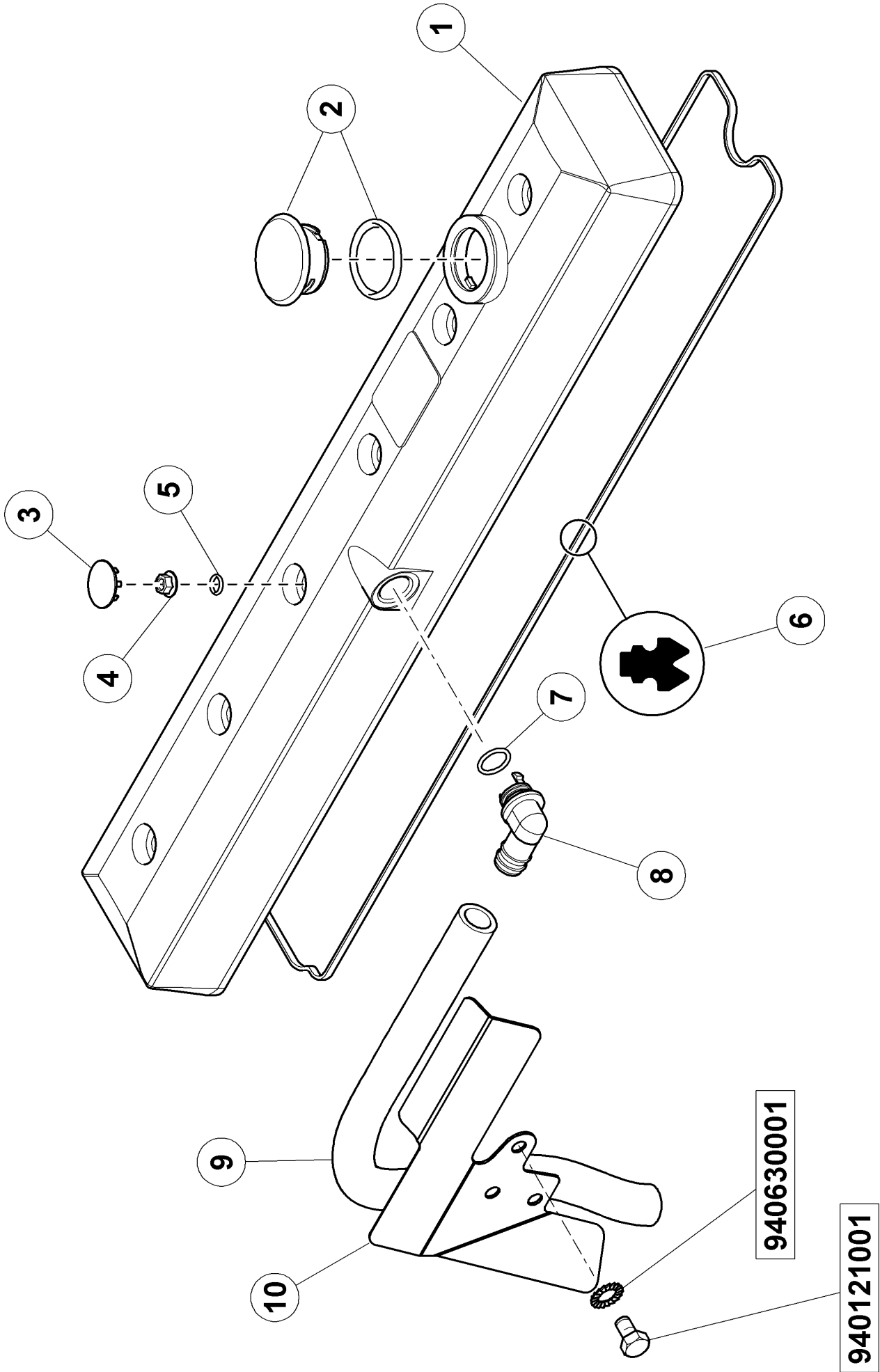

**120 CYLINDER HEAD COVER**

| <b>Pos.</b> | <b>Part No.</b>      | <b>Description</b> | <b>Dimension</b>     | <b>Quantity</b> | <b>Conditions</b> |
|-------------|----------------------|--------------------|----------------------|-----------------|-------------------|
| 1           | <b>60 0502 149 3</b> | ROCKER COVER       |                      | 1               |                   |
| 2           | <b>60 0502 149 5</b> | LOCK               |                      | 1               |                   |
| 3           | <b>60 0502 134 4</b> | PLUG               |                      | 6               |                   |
| 4           | <b>60 0502 149 4</b> | FLANGE NUT         |                      | 6               |                   |
| 5           | <b>60 0502 134 7</b> | O-RING             | W.ERS. D. 0219 147.0 | 6               |                   |
| 6           | <b>60 0502 134 5</b> | SEALING RING       |                      | 1               |                   |
| 7           | <b>60 0500 901 5</b> | O-RING             |                      | 1               |                   |
| 8           | <b>60 0503 026 5</b> | SCREWING           |                      | 1               |                   |
| 9           | <b>60 0503 048 0</b> | HOSE               |                      | 1               |                   |
| 10          | <b>00 1105 007 0</b> | DEFLECTOR          |                      | 1               |                   |
| 94012       | <b>77 0310 114 0</b> | SCREW              | M 10X16              | 1               |                   |
| 1001        |                      |                    |                      |                 |                   |
| 94063       | <b>79 0305 601 7</b> | WASHER             | A10,5                | 1               |                   |
| 0001        |                      |                    |                      |                 |                   |

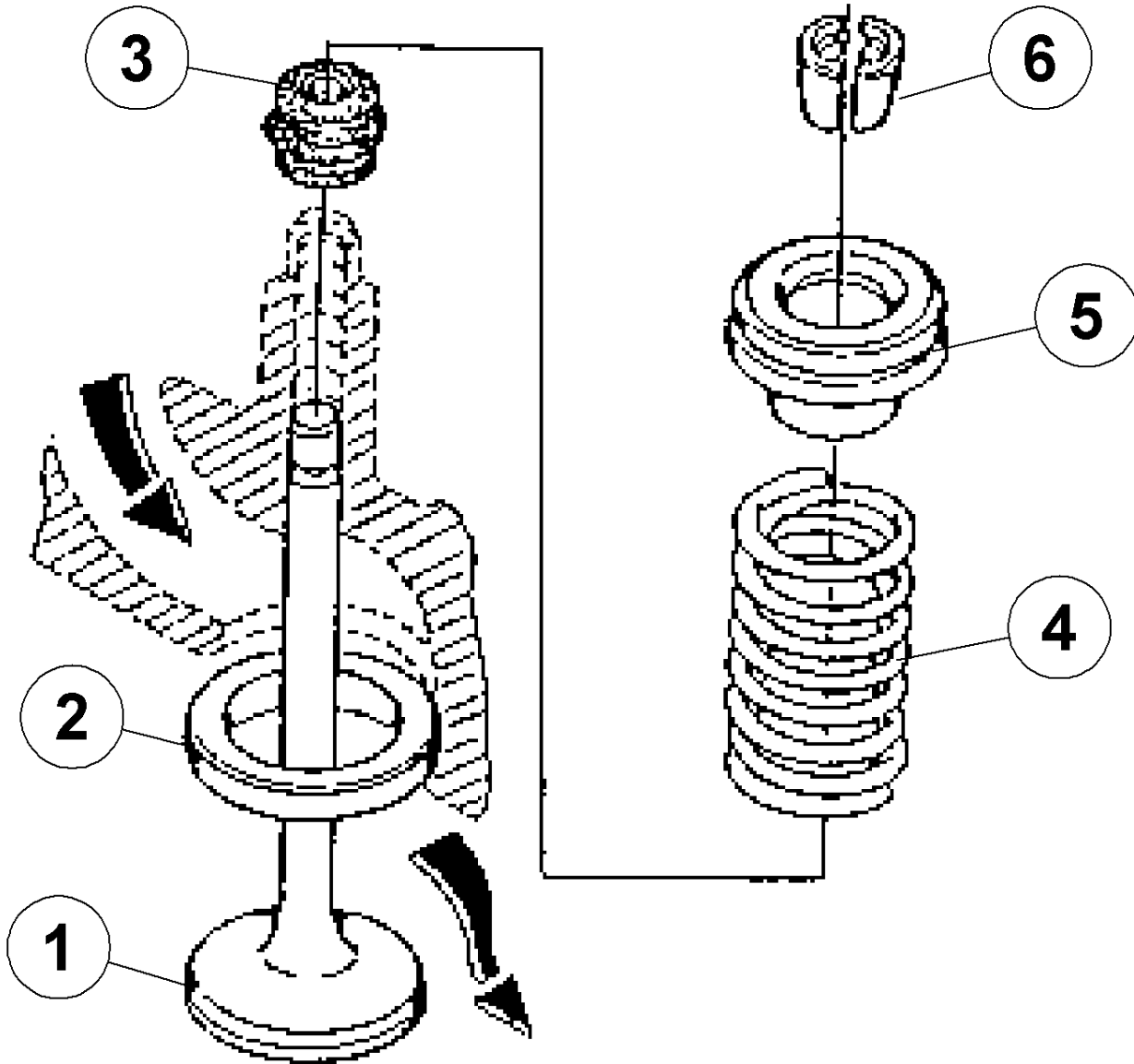

**140 VALVES**

| <b>Pos.</b> | <b>Part No.</b>      | <b>Description</b> | <b>Dimension</b> | <b>Quantity</b> | <b>Conditions</b> |
|-------------|----------------------|--------------------|------------------|-----------------|-------------------|
| 1           | <b>60 0501 290 8</b> | ENGINE VALVE       |                  | 6               |                   |
| 1           | <b>60 0501 290 9</b> | ENGINE VALVE       |                  | 6               | 1)                |
| 2           | <b>60 0501 291 0</b> | VALVE SEAT         |                  | 6               |                   |
| 3           | <b>60 0501 291 1</b> | SEALING RING       |                  | 6               |                   |
| 4           | <b>60 0501 291 3</b> | SPRING             |                  | 6               |                   |
| 5           | <b>60 0501 291 4</b> | RETAINER           |                  | 6               |                   |
| 6           | <b>60 0501 291 5</b> | HALF-CONE          |                  | 12              |                   |
| <b>1)</b>   | <b>Remarks</b>       |                    | +0,38mm          |                 |                   |

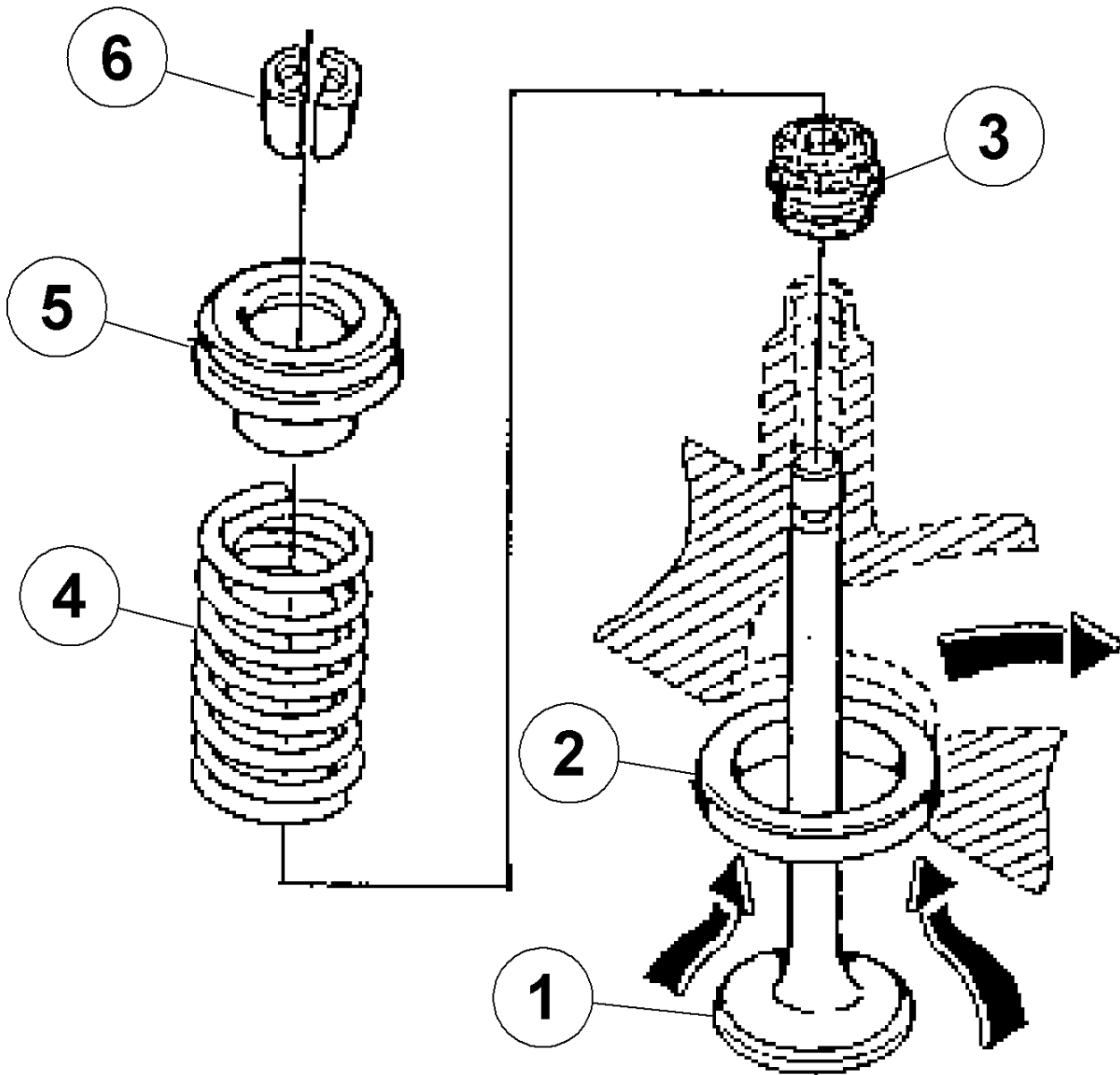

**140 VALVES**

| <b>Pos.</b> | <b>Part No.</b>      | <b>Description</b> | <b>Dimension</b> | <b>Quantity</b> | <b>Conditions</b> |
|-------------|----------------------|--------------------|------------------|-----------------|-------------------|
| 1           | <b>60 0501 291 6</b> | ENGINE VALVE       |                  | 6               |                   |
| 1           | <b>60 0501 291 7</b> | ENGINE VALVE       |                  | 6               | 1)                |
| 2           | <b>60 0501 291 8</b> | VALVE SEAT         |                  | 6               |                   |
| 3           | <b>60 0501 291 1</b> | SEALING RING       |                  | 6               |                   |
| 4           | <b>60 0501 291 3</b> | SPRING             |                  | 6               |                   |
| 5           | <b>60 0501 291 4</b> | RETAINER           |                  | 6               |                   |
| 6           | <b>60 0501 291 5</b> | HALF-CONE          |                  | 12              |                   |
| <b>1)</b>   | <b>Remarks</b>       |                    | +0,38mm          |                 |                   |



**Suggest:**

**For more complete manuals. Please go to the home page.**

**<https://www.ebooklibonline.com>**

**If the above button click is invalid. Please download this document first, and then click the above link to download the complete manual.**

**Thank you so much for reading**

**160 ROCKER ARM**

| <b>Pos.</b>   | <b>Part No.</b>      | <b>Description</b> | <b>Dimension</b> | <b>Quantity</b> | <b>Conditions</b> |
|---------------|----------------------|--------------------|------------------|-----------------|-------------------|
| 1             | <b>60 0502 150 3</b> | SHAFT              |                  | 1               |                   |
| 2             | <b>60 0501 292 9</b> | LOCK               |                  | 2               |                   |
| 3             | <b>60 0501 293 0</b> | WASHER             |                  | 1               |                   |
| 4             | <b>60 0502 150 4</b> | ROCKER ARM         |                  | 12              |                   |
| 5             | <b>60 0502 150 5</b> | SUPPORT            |                  | 6               |                   |
| 6             | <b>60 0501 293 4</b> | SPRING             |                  | 5               |                   |
| 7             | <b>60 0501 293 3</b> | WASHER             |                  | 6               |                   |
| 8             | <b>60 0502 150 6</b> | STUD BOLT          |                  | 6               |                   |
| 9             | <b>60 0502 150 7</b> | PUSHROD            |                  | 12              |                   |
| 10            | <b>60 0502 150 8</b> | ROD                |                  | 12              |                   |
| 94041<br>4101 | <b>77 0303 212 4</b> | NUT                | M 10             | 1               |                   |

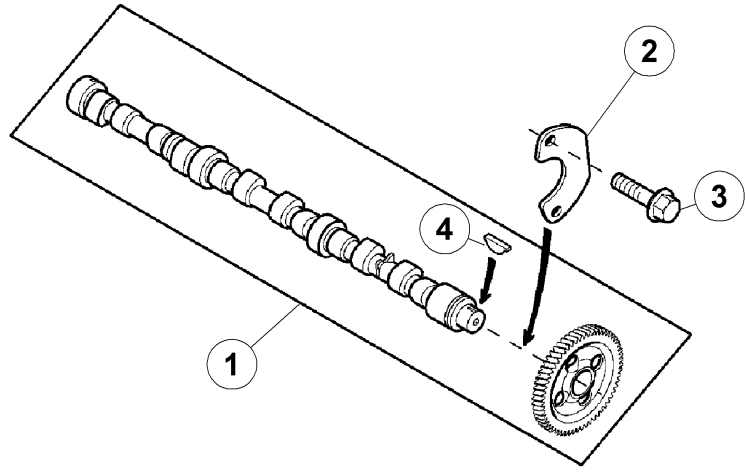

**180 CAMSHAFT, CAMSHAFT BEARING BUSHES**

| <b>Pos.</b> | <b>Part No.</b>      | <b>Description</b> | <b>Dimension</b> | <b>Quantity</b> | <b>Conditions</b> |
|-------------|----------------------|--------------------|------------------|-----------------|-------------------|
| 1           | <b>60 0502 869 9</b> | CAMSHAFT           |                  | 1               |                   |
| 2           | <b>60 0502 151 1</b> | PLATE              |                  | 1               |                   |
| 3           | <b>60 0502 145 6</b> | SCREW              | M8X25            | 2               |                   |
| 4           | <b>60 0502 151 0</b> | KEY                |                  | 1               |                   |

**<https://www.ebooklibonline.com>**

Hello dear friend!

Thank you very much for reading.

Enter the link into your browser.

The full manual is available for immediate download.

**<https://www.ebooklibonline.com>**