

010 COMPLETE ENGINE

Pos.	Part No.	Description	Dimension	Quantity	Conditions
2	77 0005 599 8	ENGINE		1	1)
-		<i>Please order additionally!</i>			
	77 0005 997 8	HEXAGON HEAD BOLT		6,000	
		<i>Please order additionally!</i>			
	77 0103 068 6	BEARING-1 BALL		1,000	
		<i>Please order additionally!</i>			
	77 0001 693 5	SCREW		8,000	
	77 0005 277 4	TORSION DAMPER		1,000	
2	77 0004 707 2	ENGINE		1	2)
-		<i>Please order additionally!</i>			
	77 0103 068 6	BEARING-1 BALL		1,000	
1)	Homologationtype		+ 4112 ->PL.10.1.03.A		
2)	Homologationtype		+ 4122 ->PL.10.1.03.A		

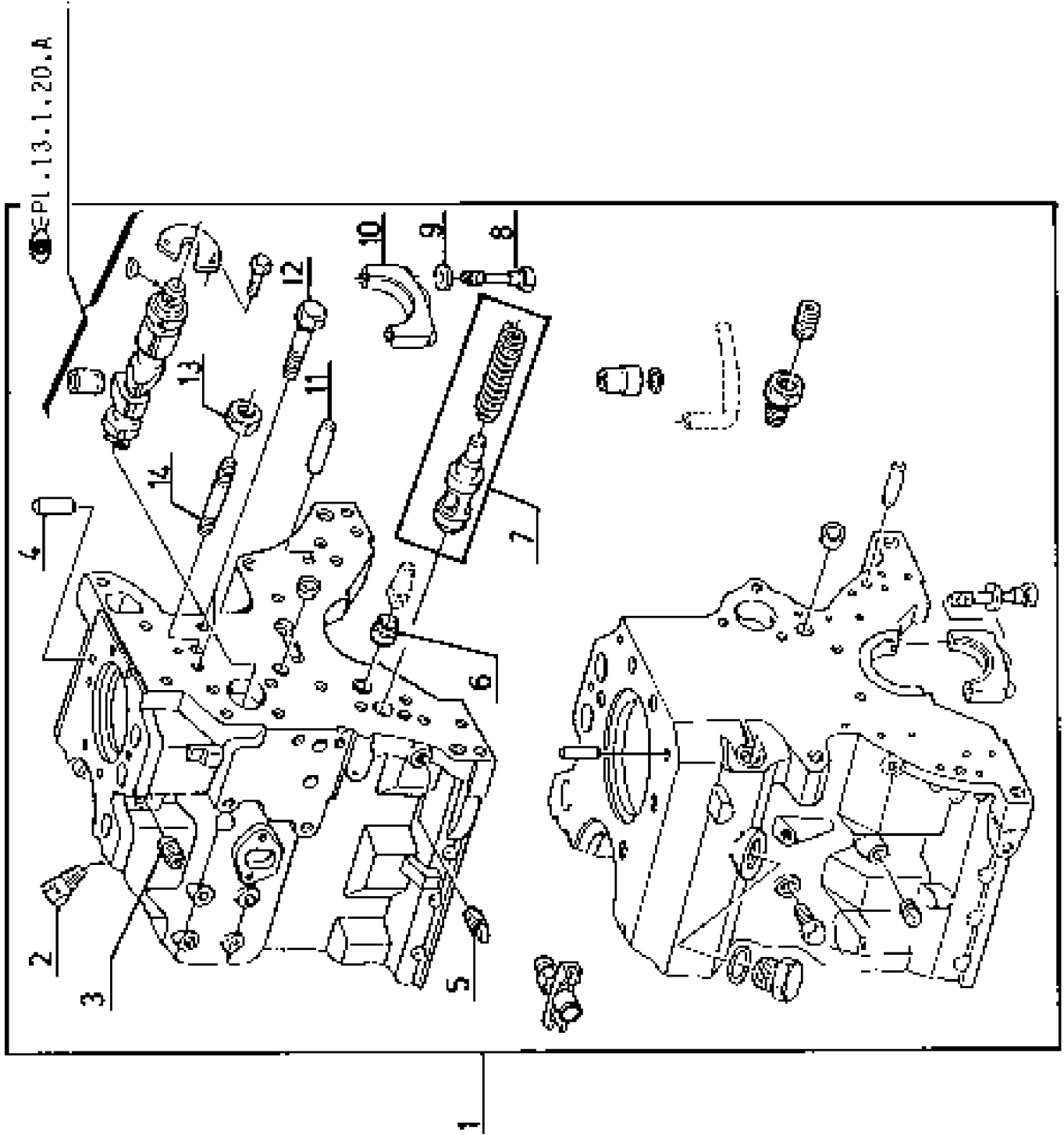

<https://www.ebooklibonline.com>

Hello dear friend!

Thank you very much for reading.

Enter the link into your browser.

The full manual is available for immediate download.

<https://www.ebooklibonline.com>

100 CRANKCASE

Pos.	Part No.	Description	Dimension	Quantity	Conditions
1	60 0501 597 0	CRANKCASE		1	
2	60 0501 318 9	SCREW		6	
3	60 0501 321 0	PLUG		1	
4	60 0501 317 4	CENTRING PIN		1	
5	60 0501 597 1	LOCK		1	
6	60 0501 319 9	BUSHING		1	
7	60 0501 402 9	VALVE		1	
8	60 0501 320 6	SCREW		12	
9	60 0501 320 5	WASHER		12	
10	60 0501 320 4	COVER		6	
11	60 0501 319 6	CENTRING PIN		2	
12	60 0501 319 5	SCREW		2	
13	60 0501 321 4	NUT		1	
14	60 0501 319 3	STUD BOLT		1	

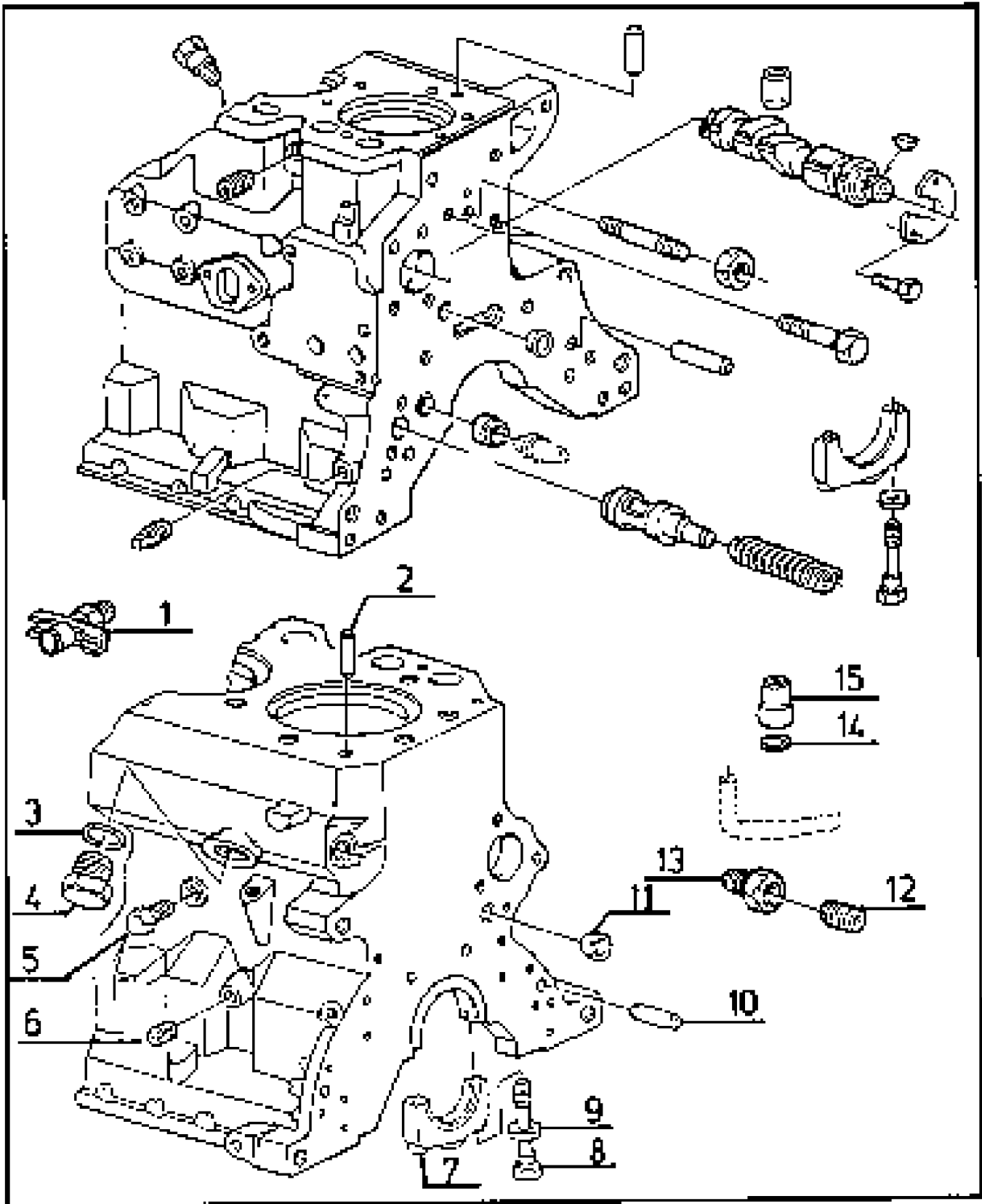

100 CRANKCASE

Pos.	Part No.	Description	Dimension	Quantity	Conditions
1	60 0501 320 7	VALVE		1	1)
2	60 0501 317 4	CENTRING PIN		1	
3	60 0502 339 4	O-RING		1	
4	60 0502 339 5	LOCK		1	
5	60 0501 320 9	LOCK		1	
6	60 0502 144 0	LOCK		7	
7	60 0501 321 2	COVER		1	
8	60 0501 320 6	SCREW		2	
9	60 0501 320 5	WASHER		2	
10	60 0501 317 4	CENTRING PIN		2	
11	60 0501 319 8	BLANKING COVER		2	
12	60 0501 321 8	LOCK		1	
13	60 0501 321 7	GREASE NIPPLE		1	
14	60 0501 320 3	O-RING		1	
15	60 0501 597 2	BUSHING		1	
1)	Remarks		[SR]		

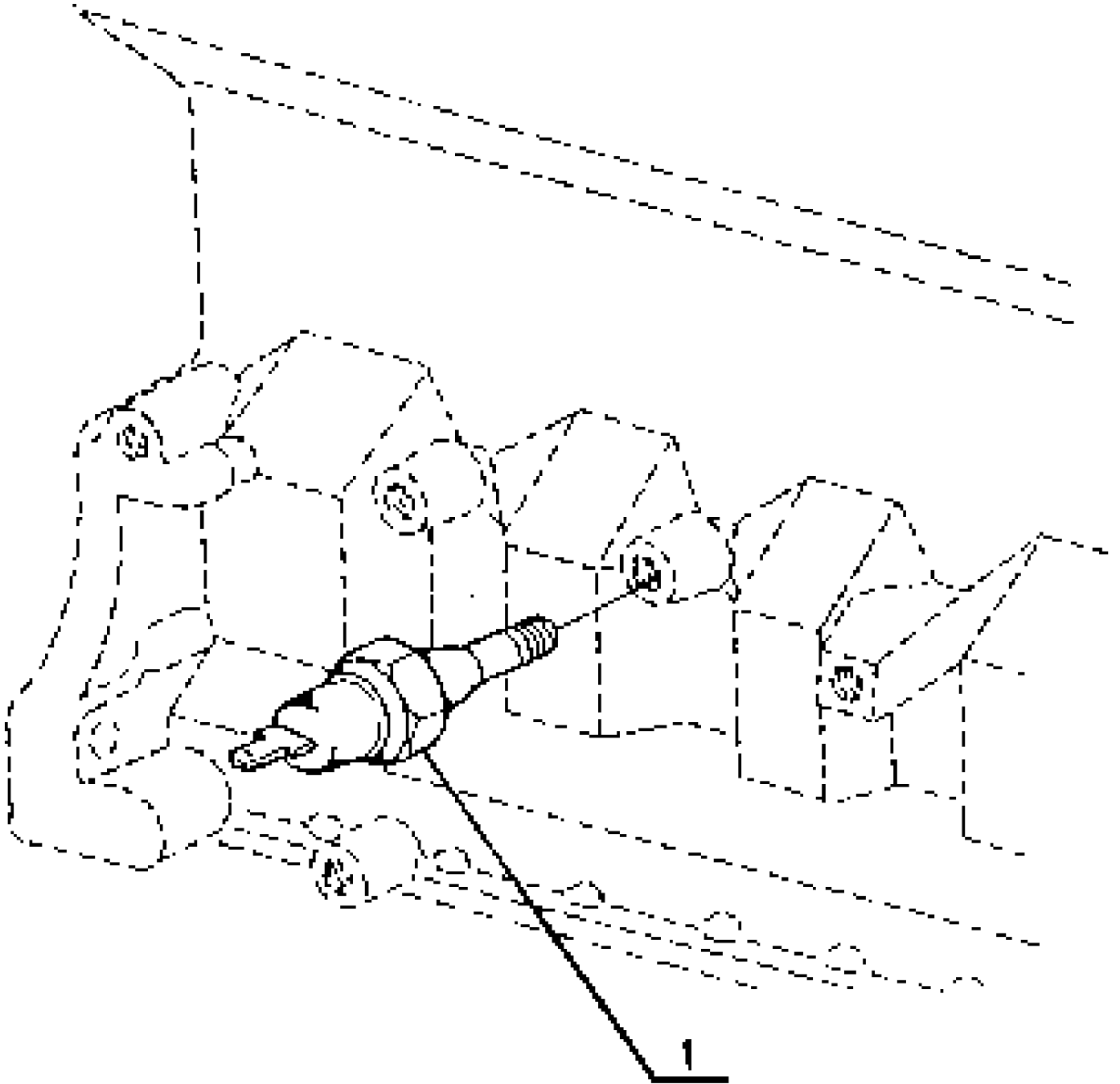

100 CRANKCASE

Pos.	Part No.	Description	Dimension	Quantity	Conditions
1	60 0501 342 7	TRANSMITTER		1	

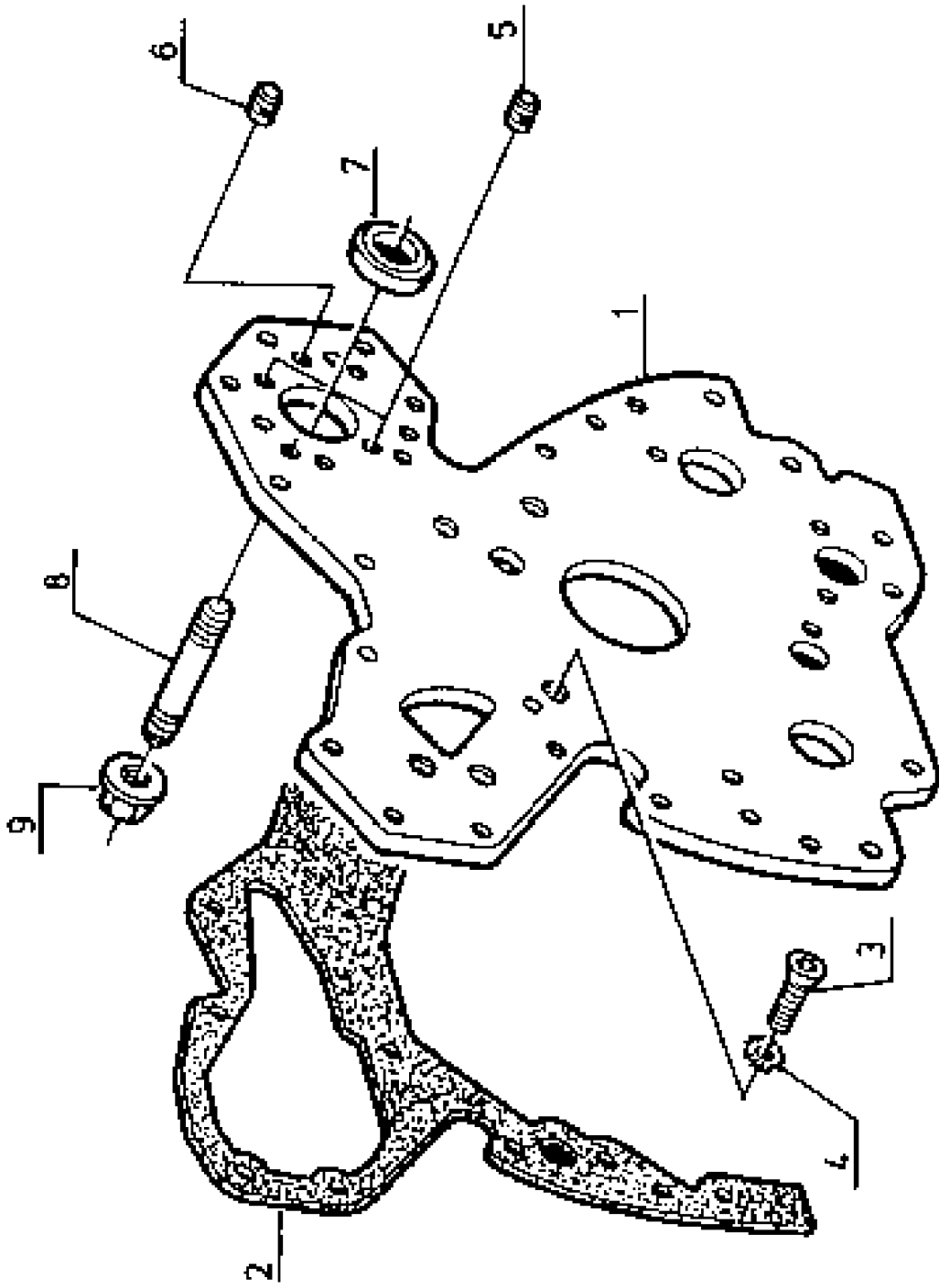

120 TIMING CASE

Pos.	Part No.	Description	Dimension	Quantity	Conditions
1	60 0501 597 3	PLATE		1	
2	60 0501 276 4	GASKET		1	
3	60 0501 276 5	SCREW		5	
4	60 0501 276 6	WASHER		5	
5	60 0501 597 4	LOCK		2	
6	60 0501 597 5	LOCK		8	
7	60 0501 597 6	RING		1	1)
8	60 0501 276 7	STUD		3	
9	60 0501 276 8	NUT		3	
1)	Remarks		[SR]		

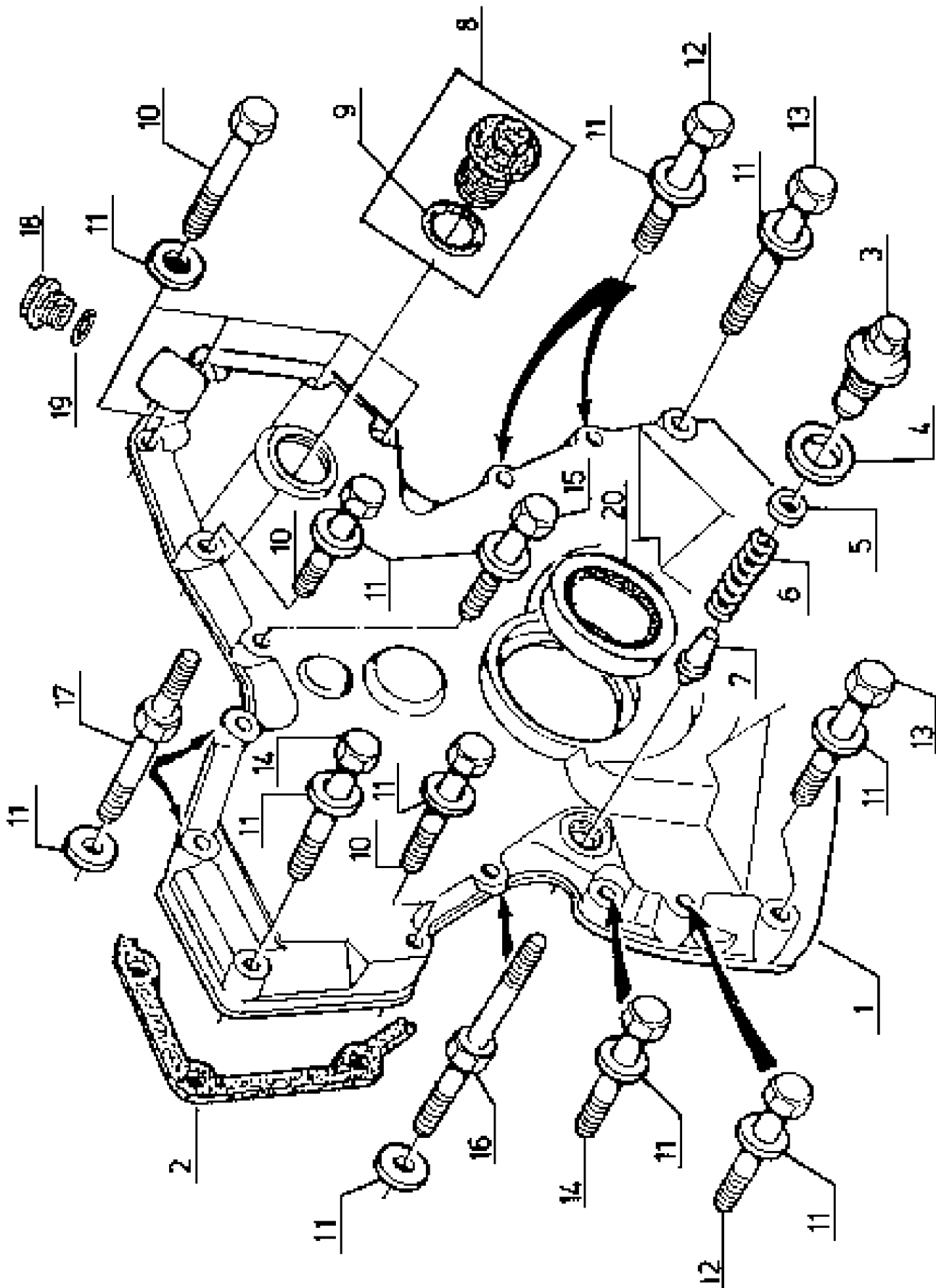

120 TIMING CASE

Pos.	Part No.	Description	Dimension	Quantity	Conditions
1	60 0501 597 7	HOUSING		1	
2	60 0501 597 8	GASKET		1	
3	60 0501 277 1	SCREW		1	
4	60 0501 277 2	WASHER		1	
5	60 0501 277 3	ADJUSTING DISC		1	1)
6	60 0501 277 4	SPRING		1	
7	60 0501 277 5	VALVE		1	
8	60 0501 277 6	LOCK		1	
9	60 0501 277 7	O-RING		1	
10	60 0501 277 8	SCREW		6	
11	60 0501 336 9	WASHER		17	
12	60 0501 278 0	SCREW		3	
13	60 0501 277 9	SCREW		2	
14	60 0501 278 1	SCREW		2	
15	60 0501 319 5	SCREW		1	
16	60 0502 233 3	STUD BOLT		1	
17	60 0502 233 4	STUD BOLT		2	
18	60 0502 895 5	SCREW PLUG	F-M20X1,5	1	
19	77 0002 464 6	O-RING	17X2-N ERS.D. 0238209.0	1	
20	60 0501 278 3	SHAFT SEAL		1	

1) Remarks [SR]

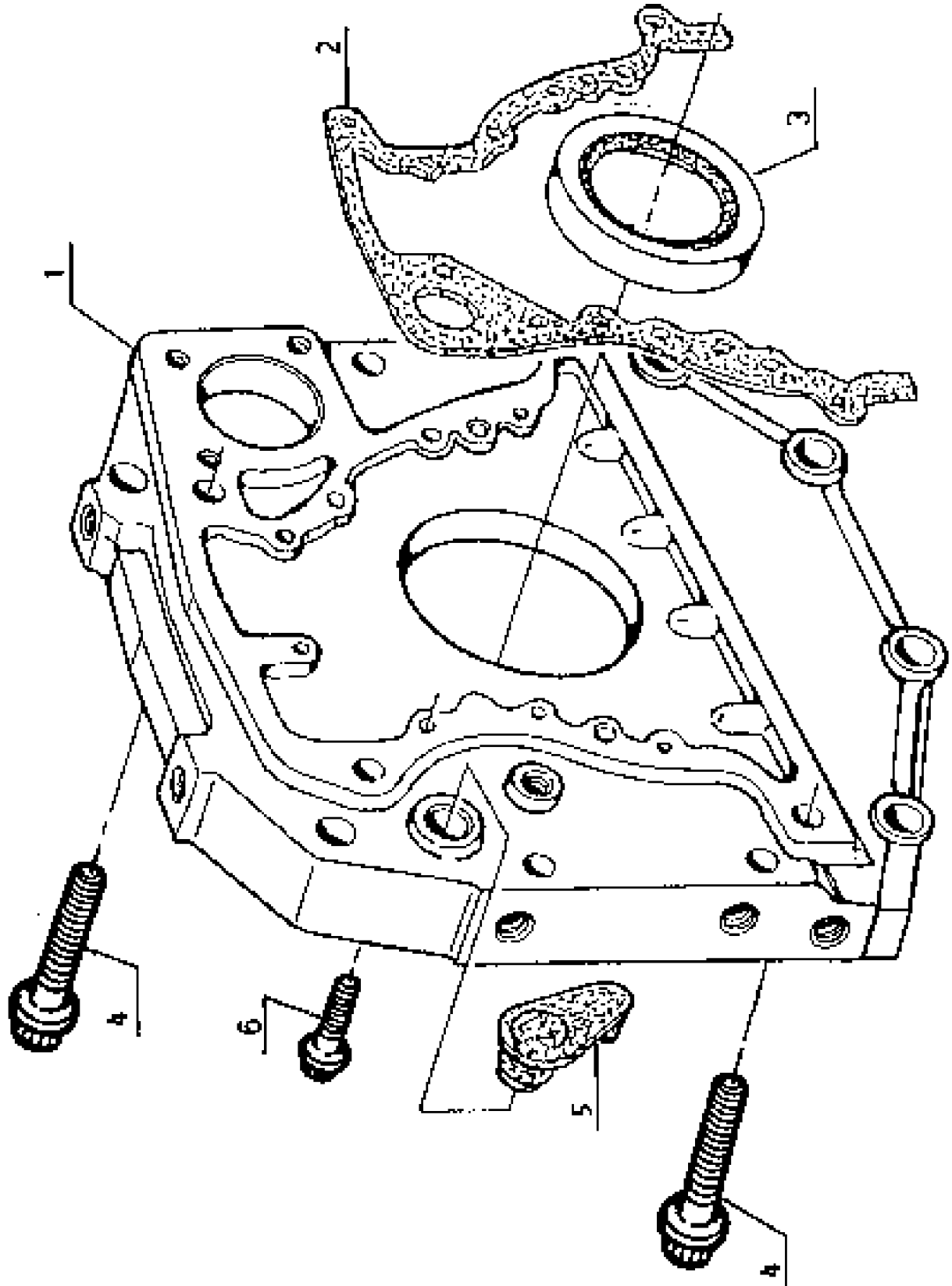

140 FLYWHEEL HOUSING 1)

Pos.	Part No.	Description	Dimension	Quantity	Conditions
1	FA-CONSIGN ES	Consignes - CS		1	
-		<i>Please order!</i>			
	60 0501 604 9	O-RING		1,000	
	60 0502 146 4	LOCK		1,000	
	77 0005 577 0	HOUSING		1,000	
	77 0005 577 1	GASKET		1,000	
2	60 0501 278 5	GASKET		1	
3	60 0501 279 0	SHAFT SEAL	118X146X15	1	
4	60 0501 480 7	SCREW		4	
5	60 0501 611 6	BLANKING COVER		1	
6	60 0501 480 8	SCREW		8	
1)	machine no.	4112			up to CT12S0782
	machine no.	4122			up to CT22S0250

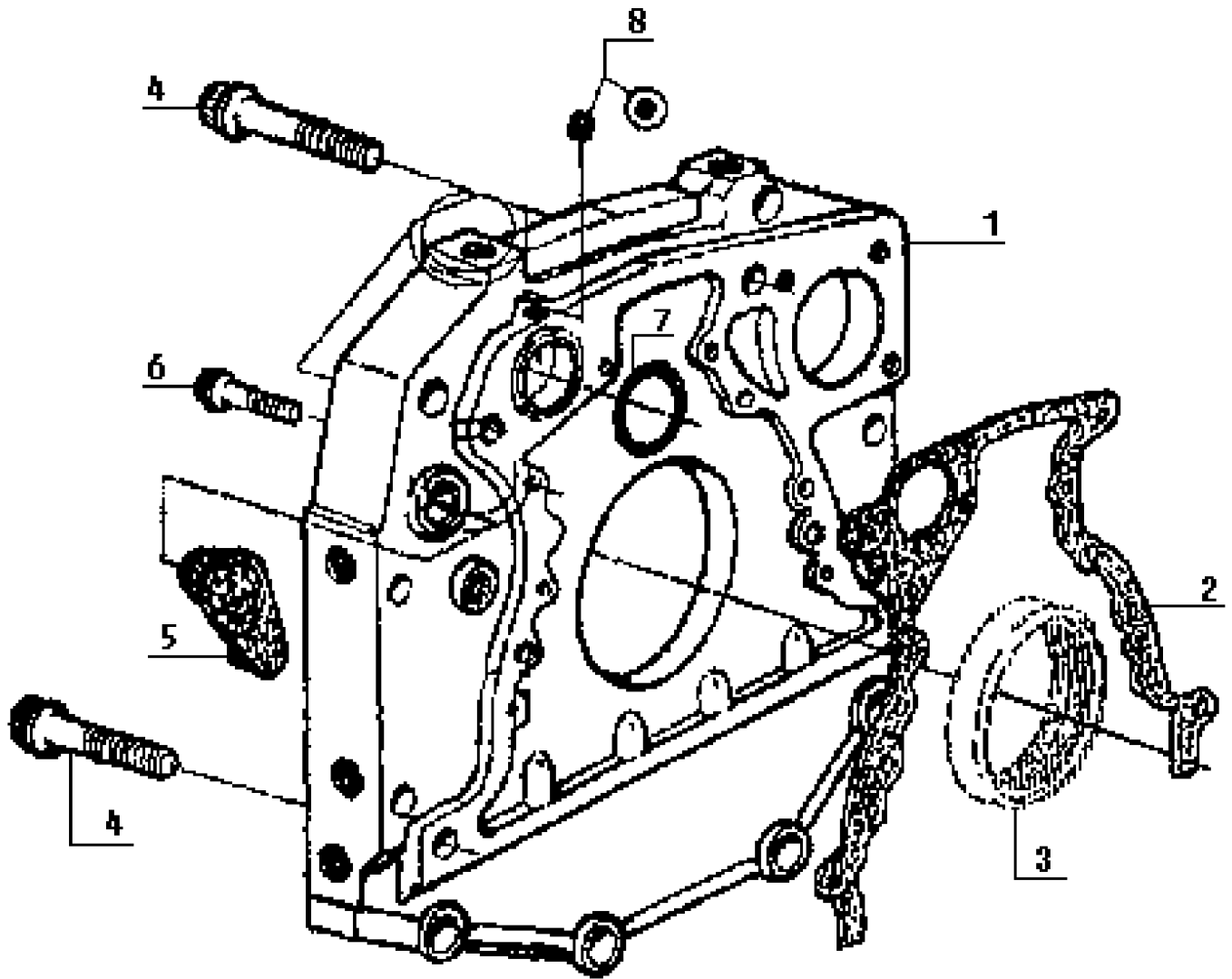

140 FLYWHEEL HOUSING 1)

Pos.	Part No.	Description	Dimension	Quantity	Conditions
1	FA-CONSIGN ES	Consignes - CS		1	
-		<i>Please order!</i>			
	60 0501 604 9	O-RING		1,000	
	77 0005 577 0	HOUSING		1,000	
	77 0005 577 1	GASKET		1,000	
2	FA-CONSIGN ES	Consignes - CS		1	
-		<i>Please order!</i>			
	77 0005 577 1	GASKET		1,000	
3	60 0501 279 0	SHAFT SEAL	118X146X15	1	
4	60 0501 480 7	SCREW		4	
5	60 0501 611 6	BLANKING COVER		1	
6	60 0501 480 8	SCREW		8	
7	77 0005 079 6	O-RING		1	
8	60 0502 146 4	LOCK		1	
1)	machine no.	4112			from CT12S0783 up to CT12S1080
	machine no.	4122			from CT22S0251 up to CT22S0837

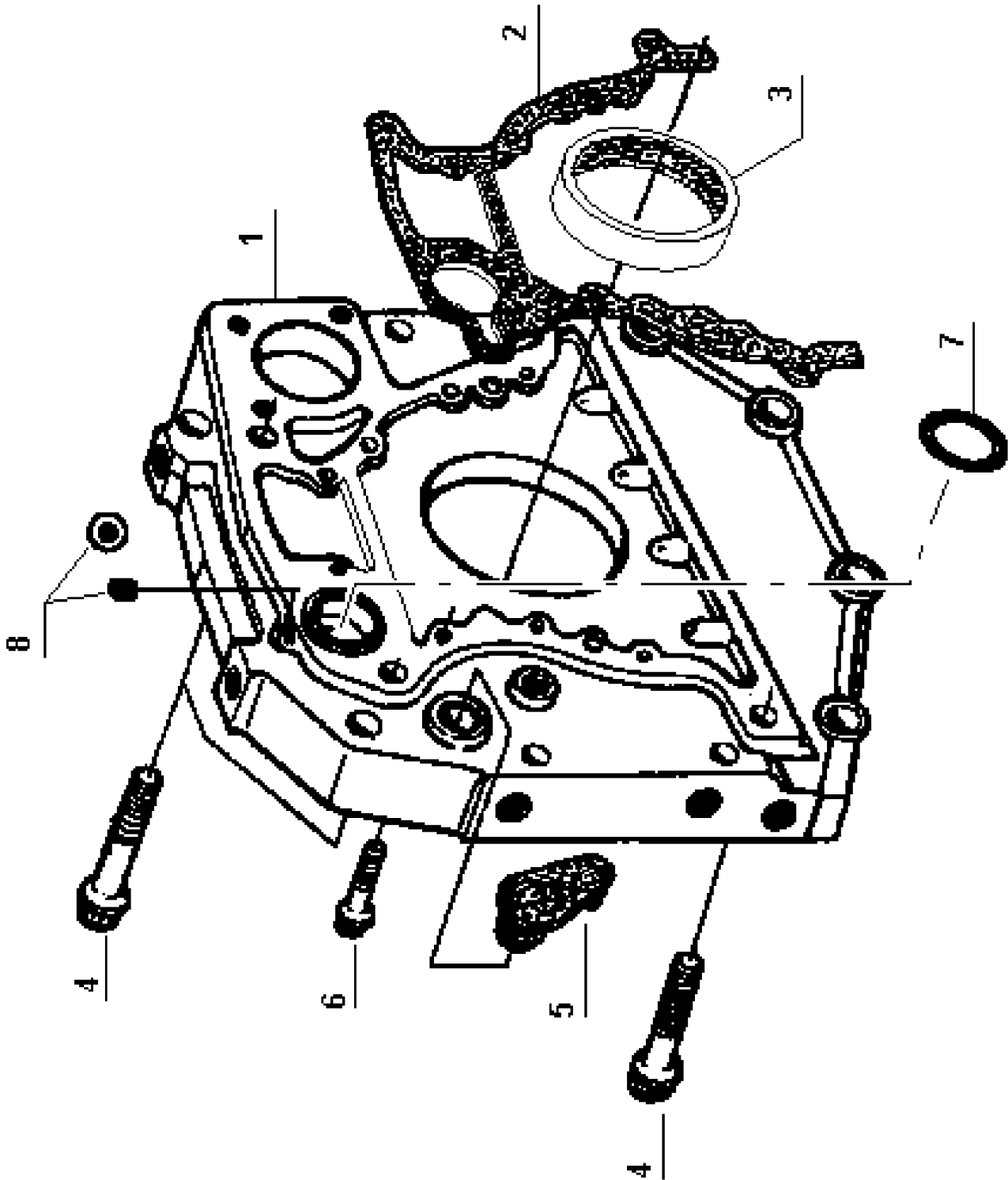

140 FLYWHEEL HOUSING 1)

Pos.	Part No.	Description	Dimension	Quantity	Conditions
1	77 0005 577 0	HOUSING		1	
2	77 0005 577 1	GASKET		1	
3	60 0501 279 0	SHAFT SEAL	118X146X15	1	
4	60 0501 480 7	SCREW		4	
5	60 0501 611 6	BLANKING COVER		1	
6	60 0501 480 8	SCREW		8	
7	60 0501 604 9	O-RING		1	
8	60 0502 146 4	LOCK		1	
1)	machine no.	4112			from CT12S1081
	machine no.	4122			from CT22S0838

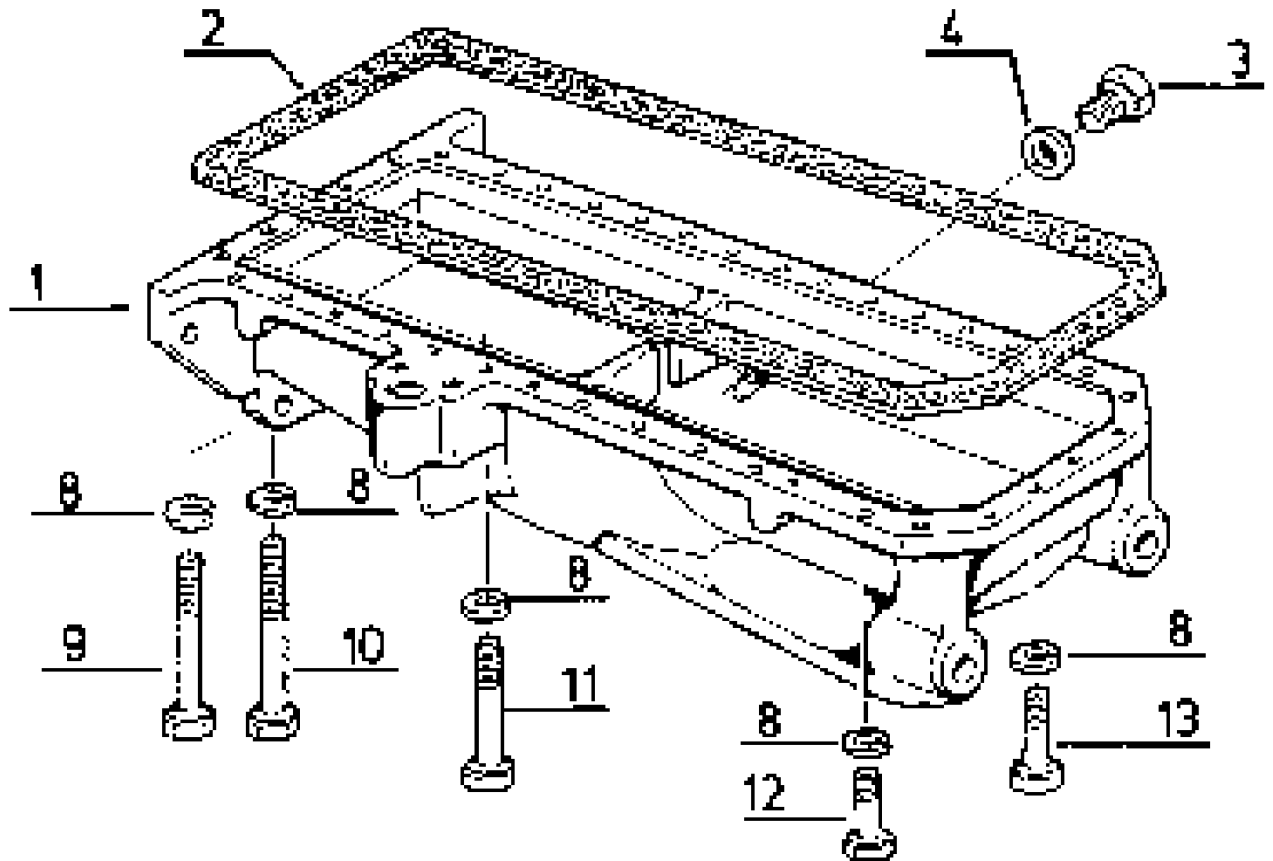
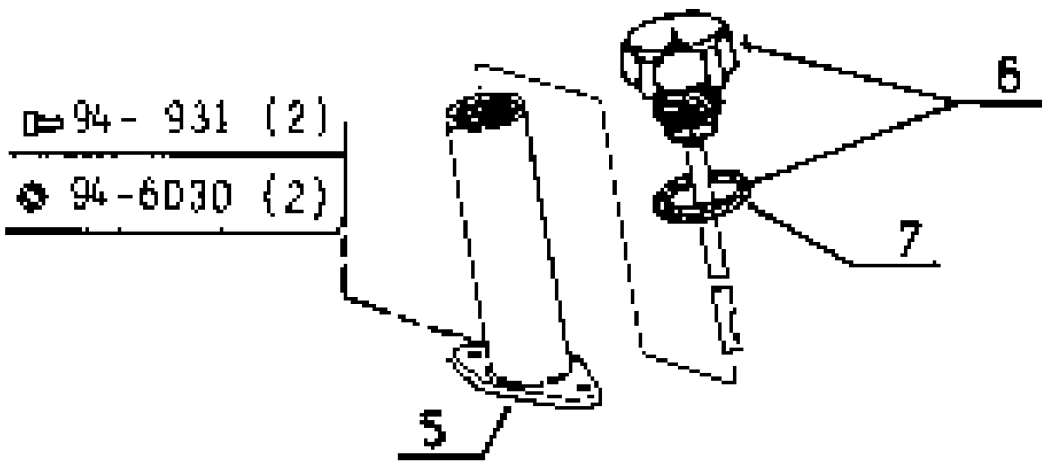

160 OIL PAN

Pos.	Part No.	Description	Dimension	Quantity	Conditions
1	60 0501 598 5	HOUSING		1	
2	60 0501 598 6	GASKET		1	
3	60 0501 279 3	LOCK		1	
4	60 0501 211 0	GASKET		1	
5	60 0501 279 4	TUBE		1	
6	60 0501 279 5	GAUGE		1	
7	60 0501 279 6	SEALING RING		1	
8	60 0501 280 0	WASHER		36	
9	60 0501 598 7	SCREW		2	
10	60 0501 598 8	SCREW		2	
11	60 0501 598 9	SCREW		2	
12	60 0501 297 8	SCREW		24	
13	60 0502 604 3	SCREW		6	

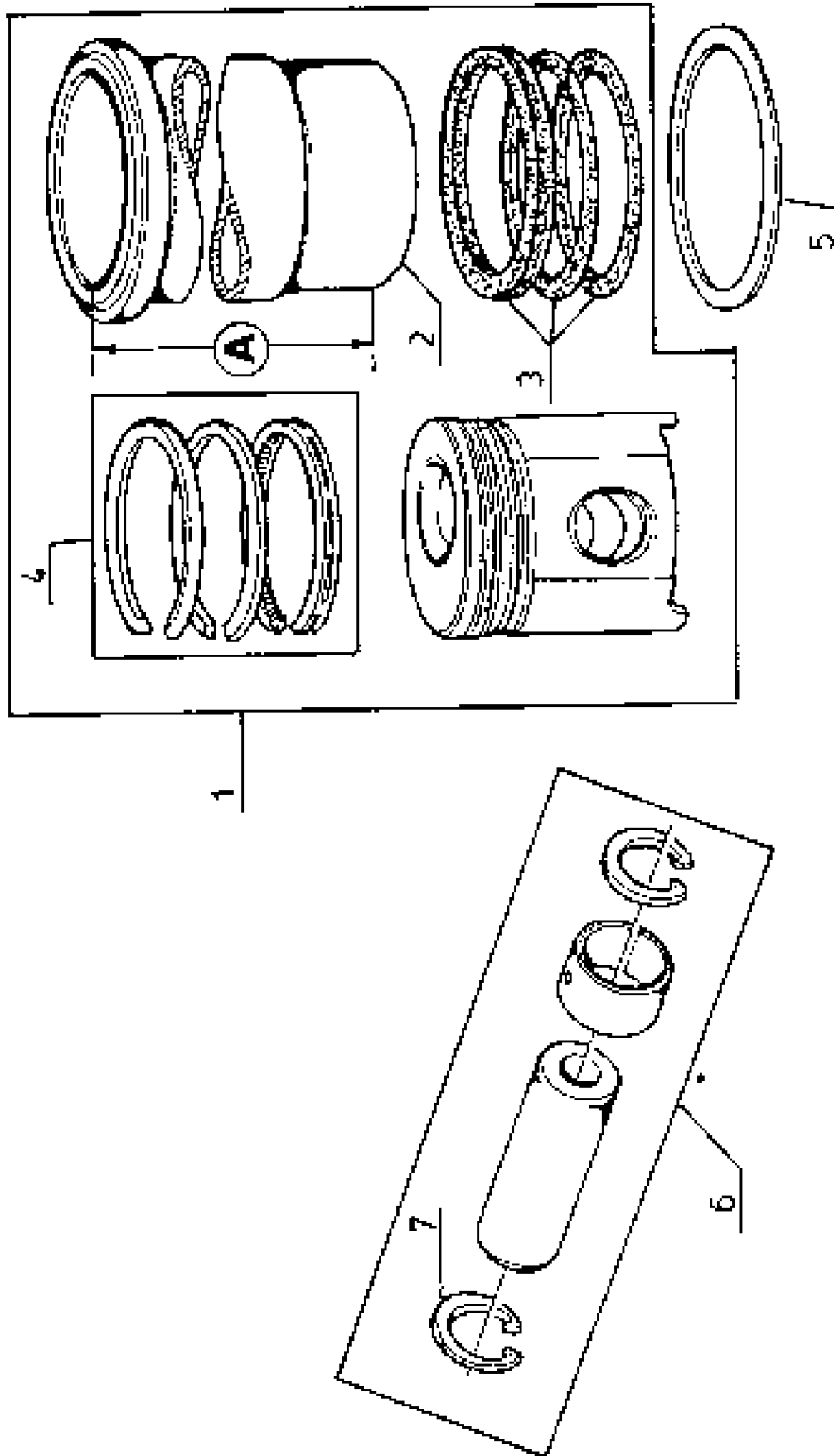

100 CYLINDER LINER, PISTON

Pos.	Part No.	Description	Dimension	Quantity	Conditions
1	60 0501 407 0	PISTON-LINER		6	
1	00 1171 024 0	PISTON-LINER		1	1)
2	FA-CONSIGNES	Consignes - CS		6	2)
-		<i>Please order!</i> <i>60 0501 407 0 PISTON-LINER</i>		1,000	
3	60 0501 280 9	SEALING RING SET		6	
4	60 0501 281 0	SET OF PISTON RINGS		6	
5	60 0501 281 5	ADJUSTING DISC		6	3)
5	60 0501 281 6	ADJUSTING DISC		6	4)
6	60 0501 591 0	AXLE		6	
7	60 0501 281 4	INNER CIRCLIP		12	

1) Remarks	Only 1 cubic capacity (1 cyl)
2) Remarks	A.218mm
3) Remarks	ép.0,05mm
4) Remarks	ép.0,10mm

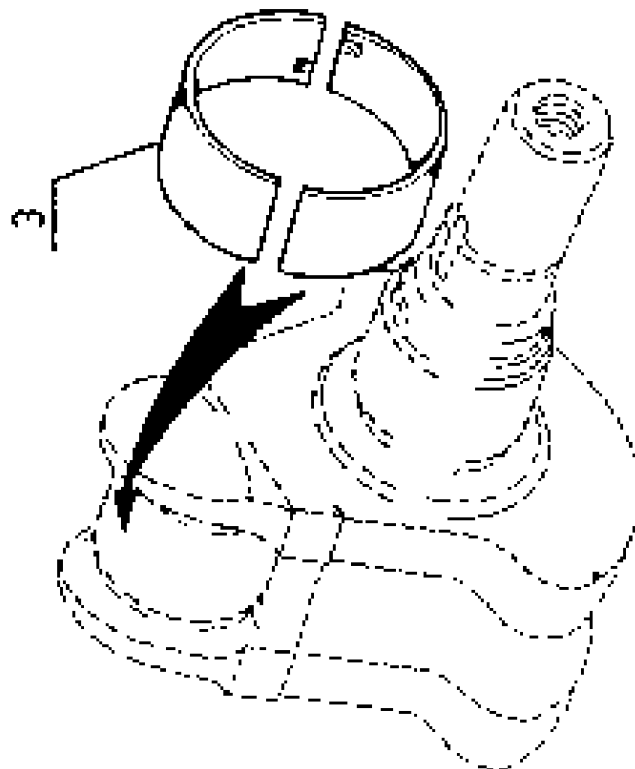
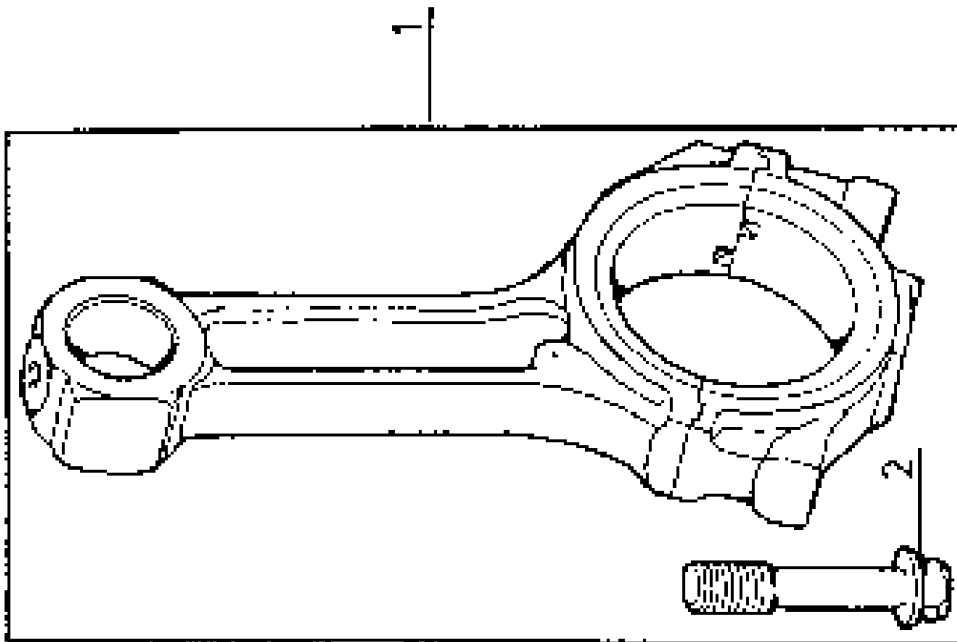

120 CONNECTING ROD, CONNECTING ROD BEARINGS

Pos.	Part No.	Description	Dimension	Quantity	Conditions
1	60 0501 281 8	ROD (ENGINE)		6	
2	60 0501 282 9	SCREW		12	
3	60 0501 282 5	BEARING		6	
3	60 0501 282 6	BEARING		1	1)
1)	Remarks		DI.0,254mm		

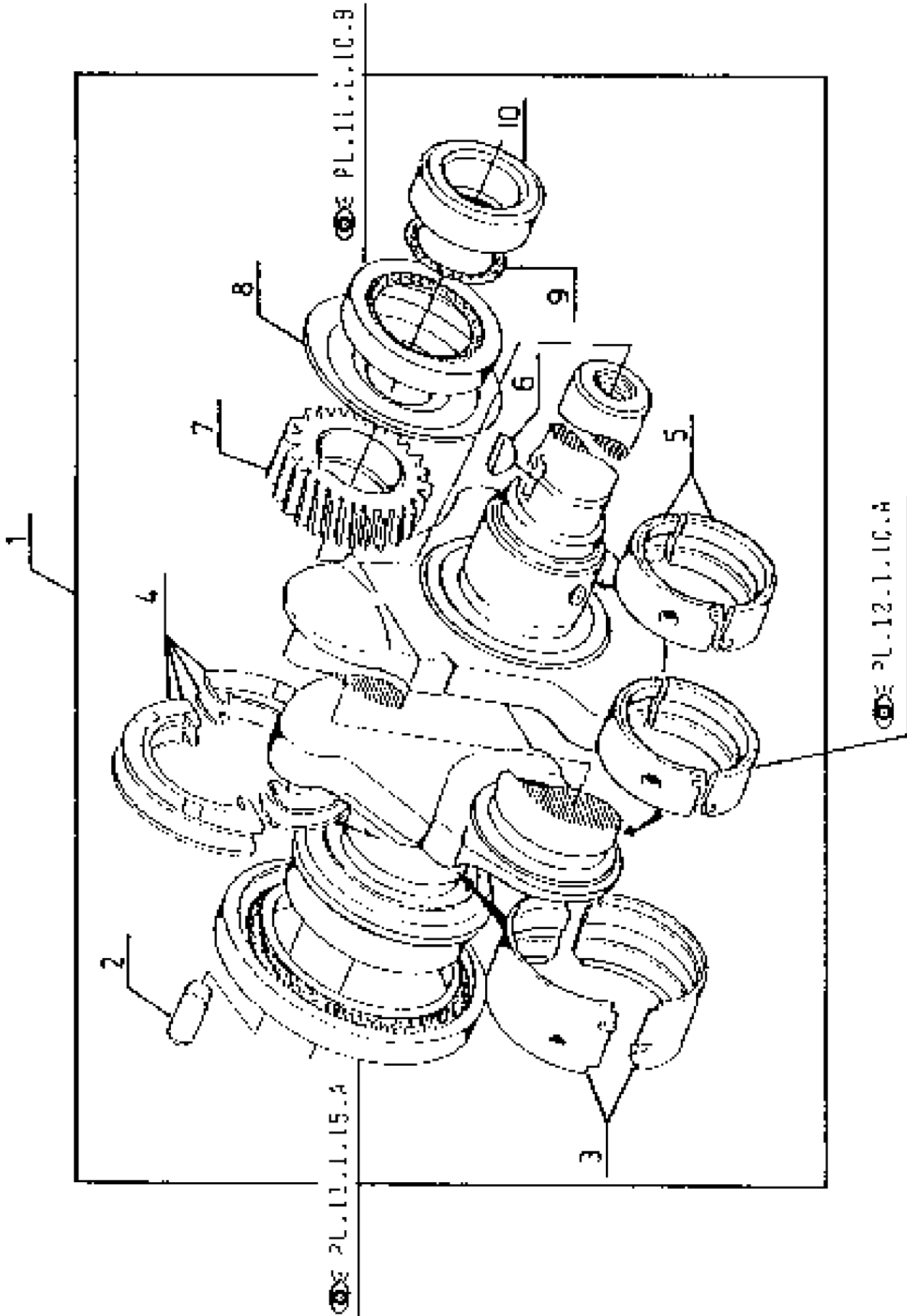

140 CRANKSHAFT

Pos.	Part No.	Description	Dimension	Quantity	Conditions
1	60 0502 761 9	CRANKSHAFT		1	
2	60 0501 317 4	CENTRING PIN		1	
3	60 0501 317 5	BEARING		1	
3	60 0501 317 6	BEARING		1	1)
4	60 0501 317 7	FLANGE		1	
4	60 0501 317 8	FLANGE		1	2)
5	60 0501 317 9	BEARING		6	
5	60 0501 318 0	BEARING		6	1)
6	60 0501 294 0	KEY		1	
7	60 0501 599 2	WHEEL		1	3)
8	60 0501 318 1	DEFLECTOR		1	
9	60 0501 318 3	O-RING		1	
10	60 0501 318 4	SLEEVE		1	

1)	Remarks	DI.0,254mm
2)	Remarks	ép.0,18
3)	Remarks	24dts.

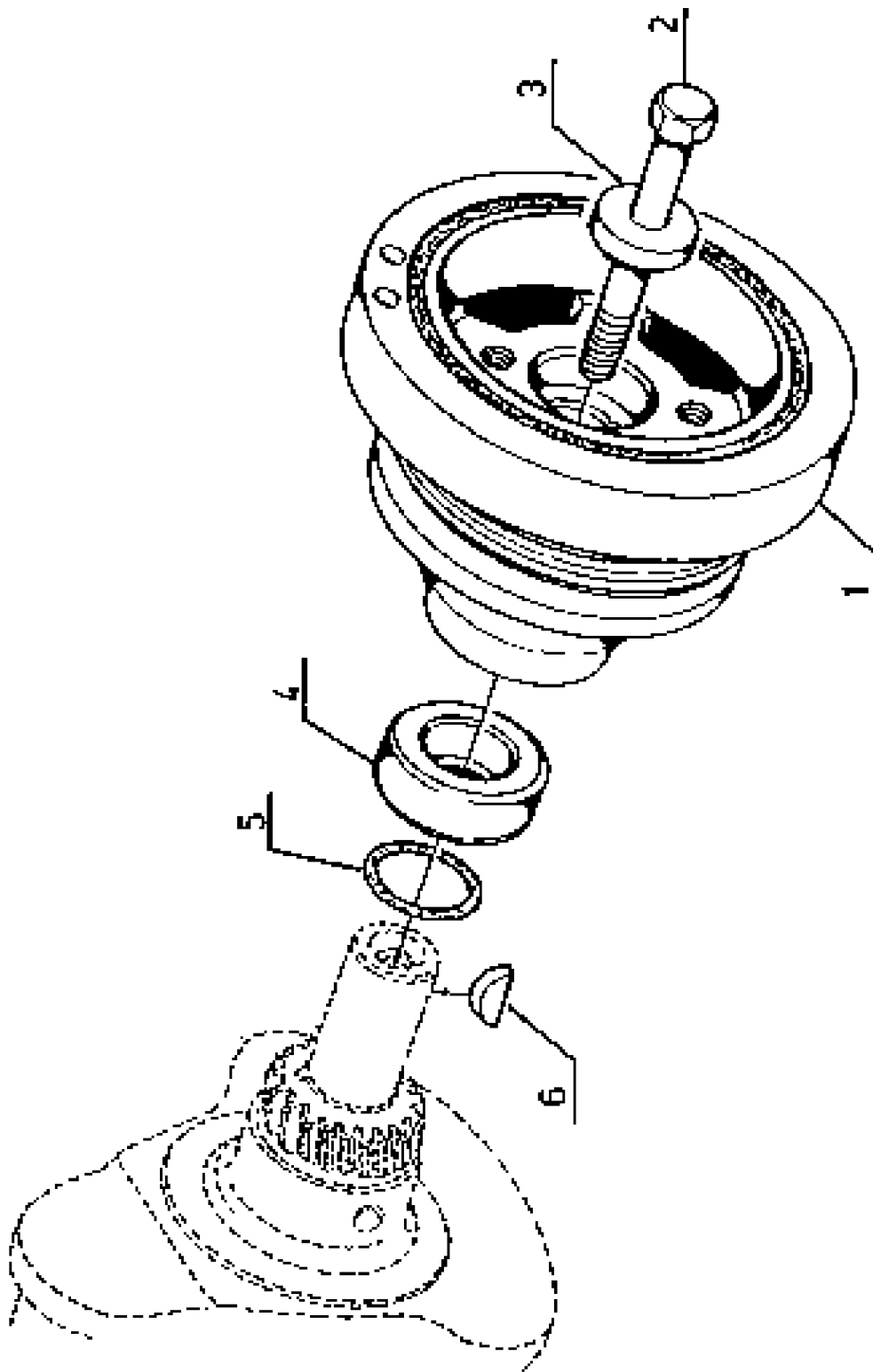

161 CRANKSHAFT PULLEY WHEEL 1)

Pos.	Part No.	Description	Dimension	Quantity	Conditions
1	77 0004 335 7	ANTI-VIBRATION WHEEL		1	
2	60 0501 608 2	SCREW		1	
3	77 0004 256 4	SPACER		1	
4	60 0501 318 4	SLEEVE		1	
5	60 0501 318 3	O-RING		1	
6	60 0501 340 5	KEY		1	
<hr/>					
1)	Equipment				
		0L0060	W/OUT FR LIFTING AND PTO		
		0L0062	FR LIFT 2.5T TE		

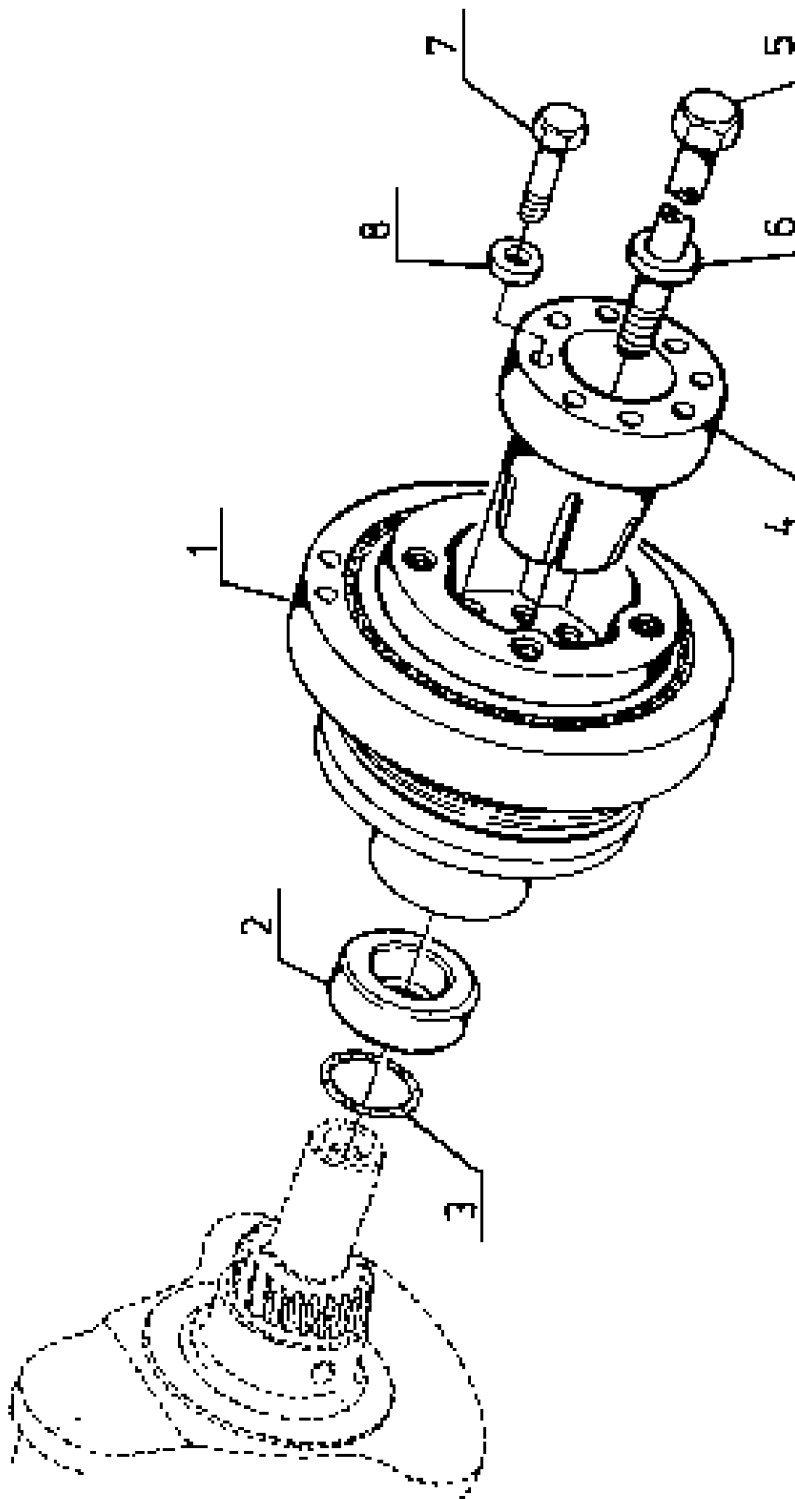

161 CRANKSHAFT PULLEY WHEEL 1)

Pos.	Part No.	Description	Dimension	Quantity	Conditions
1	60 0502 339 1	ANTI-VIBRATION WHEEL		1	
2	60 0501 318 4	SLEEVE		1	
3	60 0501 318 3	O-RING		1	
4	77 0004 256 3	HUB		1	
5	77 0004 256 5	SCREW		1	
6	77 0004 256 4	SPACER		1	
7	60 0501 278 7	SCREW		8	
8	60 0501 341 2	WASHER		8	

1) Equipment

0L0061

FR PTO

0L0063

FR LIFT AND PTO

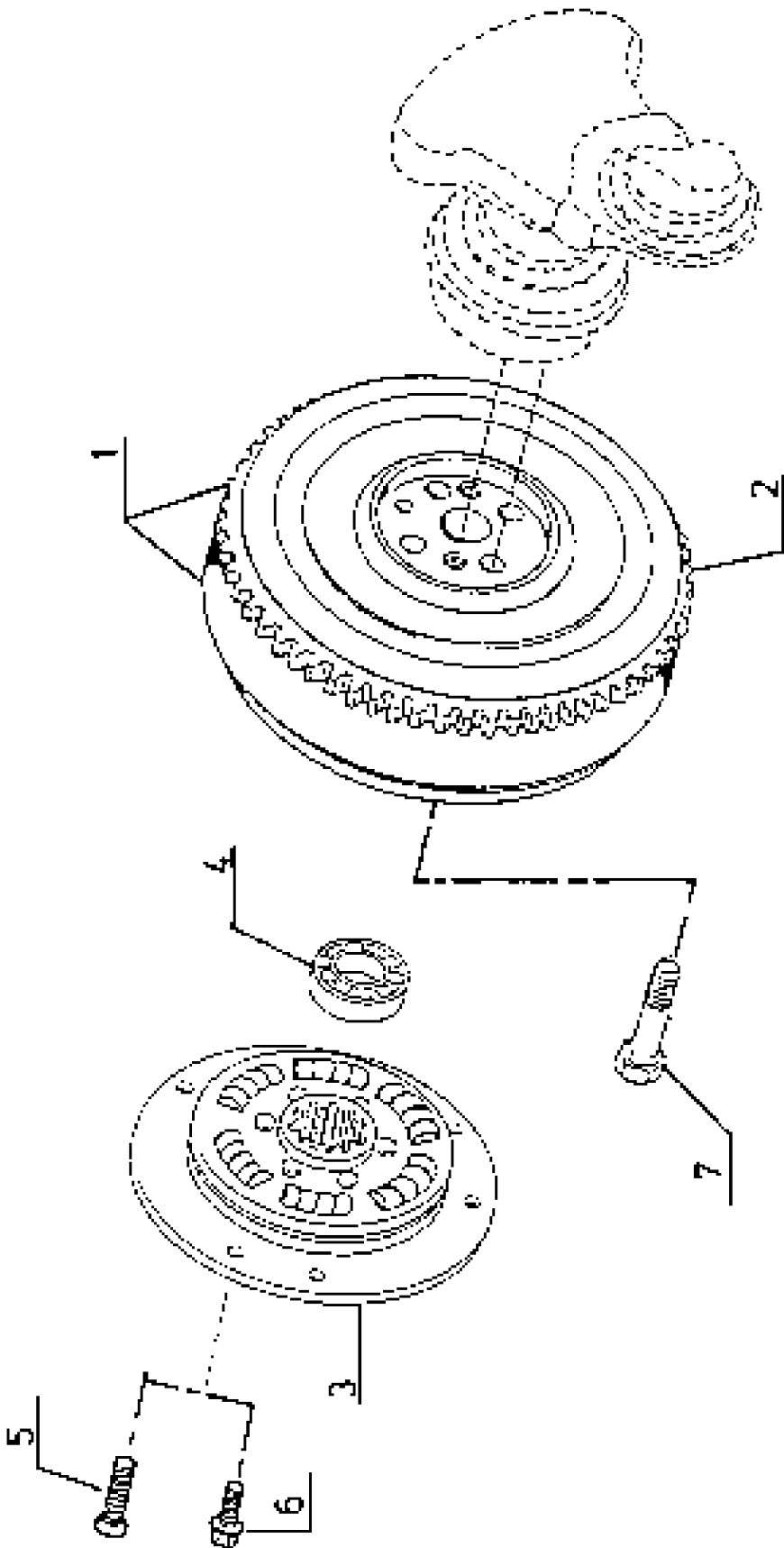

220 FLYWHEEL 1)

Pos.	Part No.	Description	Dimension	Quantity	Conditions
1	77 0005 023 5	FLYWHEEL		1	
-		<i>Please order additionally!</i>			
	77 0005 997 8	HEXAGON HEAD BOLT		6,000	2)
		<i>Please order additionally!</i>			
	77 0103 068 6	BEARING-1 BALL		1,000	
2	77 0004 531 5	TOOTHED RIM		1	3)
3	77 0004 674 3	HUB		1	
4	77 0002 745 6	BEARING-1 BALL		1	4)
4	77 0103 068 6	BEARING-1 BALL	6305-2RS	1	5)
5	77 0004 379 6	SCREW	M10X25	6	6)
6	77 0005 997 8	HEXAGON HEAD BOLT	M10X40	6	7)
7	60 0502 249 6	SCREW		4	8)
1)	Homologationtype machine no.	4112	+ 4112 up to CT12S1296		
2)	machine no.	4112	up to CT12S9998		
3)	Remarks		129dts		
4)	Remarks		25 x52 x15		
5)	Remarks		25x62x17		
6)	machine no.		- CT12S0616 - CT12S0617 - CT12S0618 - CT12S0619		
	machine no.	4112	up to CT12S0624		
7)	machine no.		+ CT12S0616 + CT12S0617 + CT12S0618 + CT12S0619		
	machine no.	4112	from CT12S0625		
8)	Remarks		1/2" x1-1/2"		

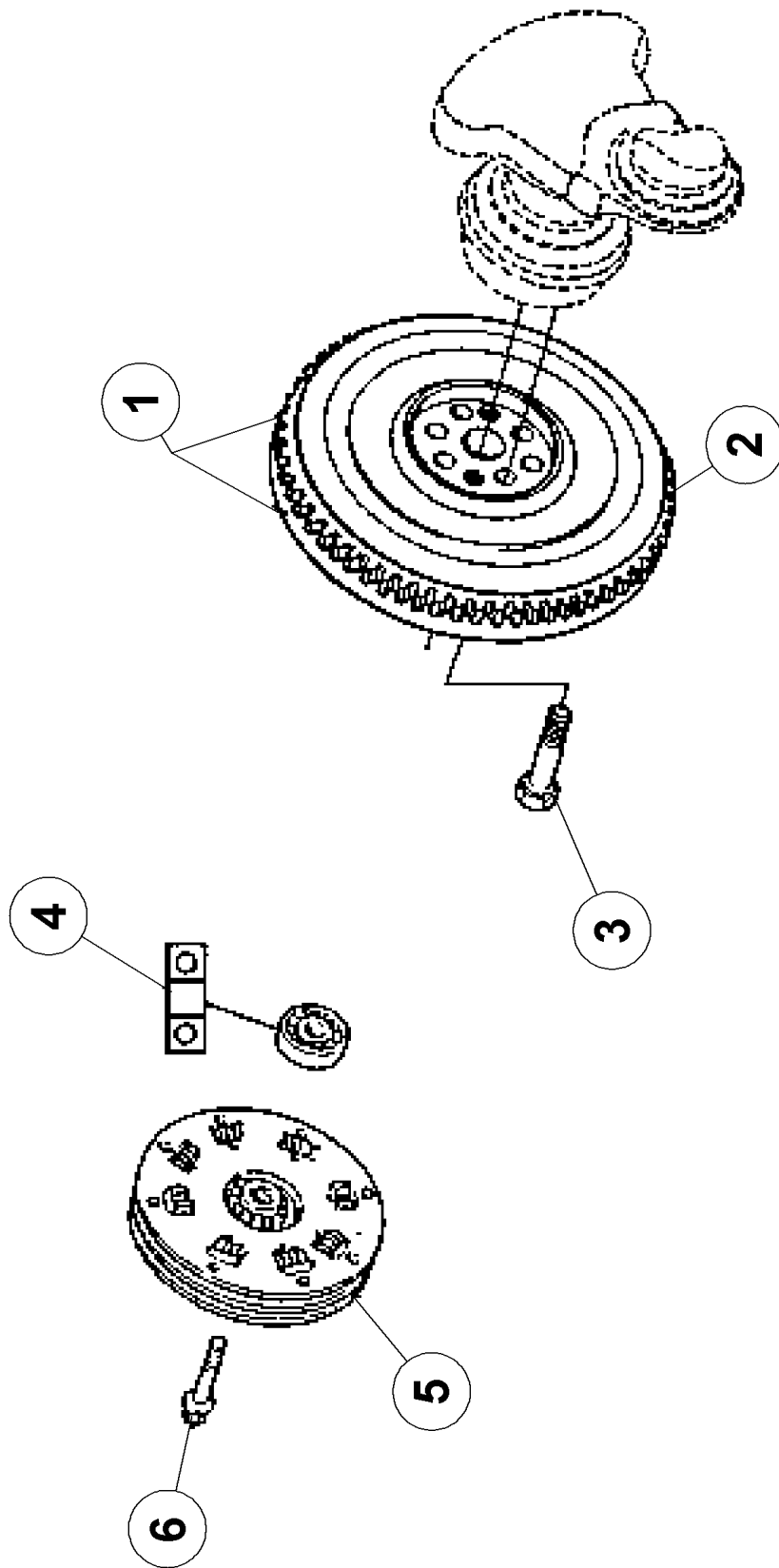

220 FLYWHEEL 1)

Pos.	Part No.	Description	Dimension	Quantity	Conditions
1	77 0004 872 4	FLYWHEEL		1	
2	77 0004 531 5	TOOTHED RIM		1	
3	60 0502 249 6	SCREW		4	2)
4	77 0103 068 6	BEARING-1 BALL	6305-2RS	1	3)
5	77 0006 703 9	TORSION DAMPER		1	
6	77 0001 693 5	SCREW	M10X40-V.RIPP ERS.D.1007	8	
1)	Homologationtype machine no.	4112	+ 4112 from CT12S1297		
2)	Remarks		1/2"x1-1/2"		
3)	Remarks		25x62x17		

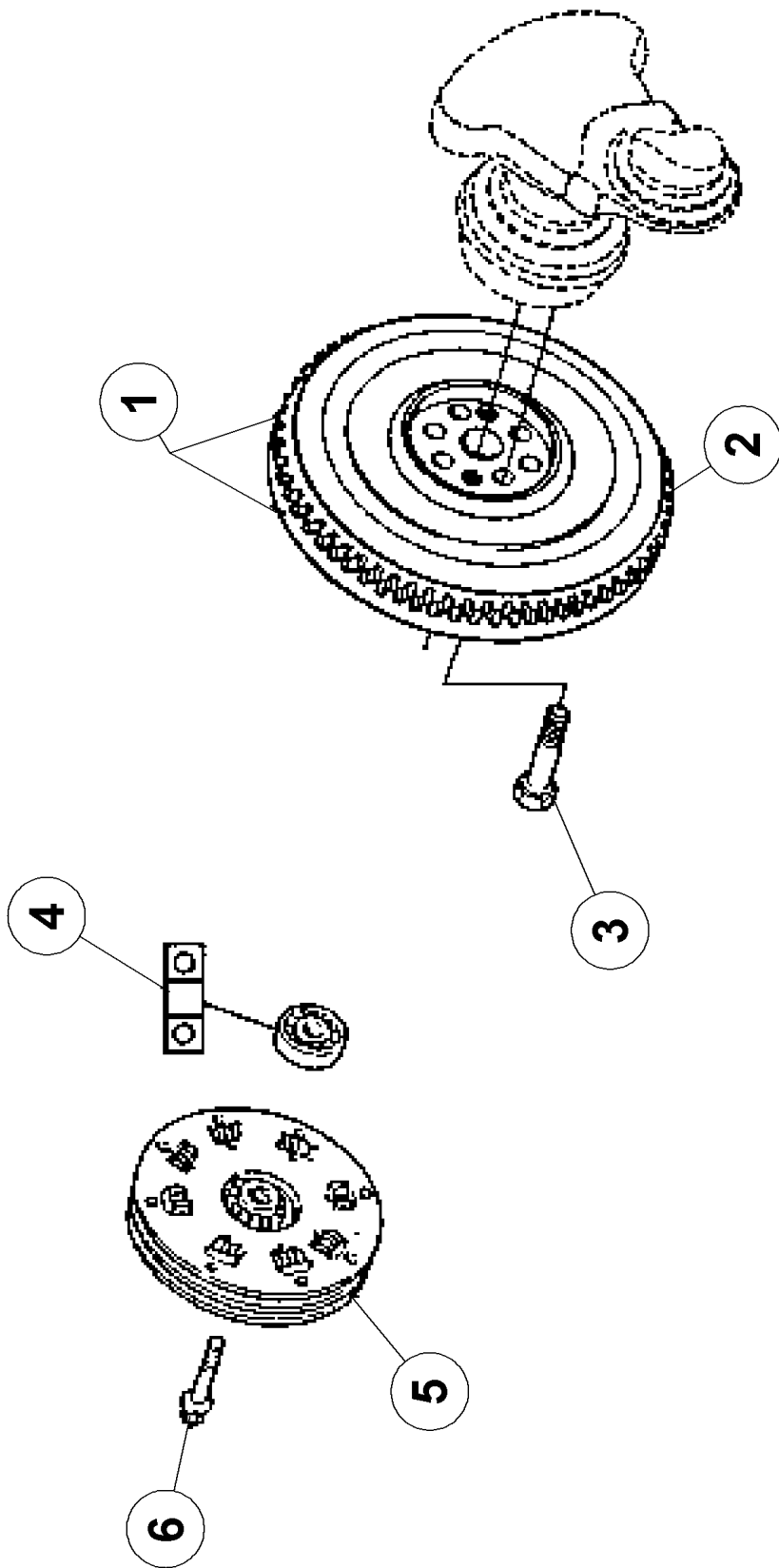



Suggest:

For more complete manuals. Please go to the home page.

<https://www.ebooklibonline.com>

If the above button click is invalid. Please download this document first, and then click the above link to download the complete manual.

Thank you so much for reading

220 FLYWHEEL 1)

Pos.	Part No.	Description	Dimension	Quantity	Conditions
1	77 0004 872 4	FLYWHEEL		1	
-		<i>Please order additionally!</i> 77 0103 068 6 BEARING-1 BALL		1,000	2)
2	77 0004 531 5	TOOTHED RIM		1	
3	60 0502 249 6	SCREW		4	3)
4	77 0103 068 6	BEARING-1 BALL	6305-2RS	1	4)
4	77 0002 745 6	BEARING-1 BALL		1	5)
5	77 0006 703 9	TORSION DAMPER		1	
6	77 0005 997 8	HEXAGON HEAD BOLT	M10X40	8	
1)	Homologationtype		+ 4122		
2)	machine no.	4122			up to CT22S0200
3)	Remarks				1/2" x1-1/2"
4)	machine no. Remarks	4122			from CT22S0201 25 x62 x17
5)	machine no. Remarks	4122			up to CT22S0200 25 x52 x15

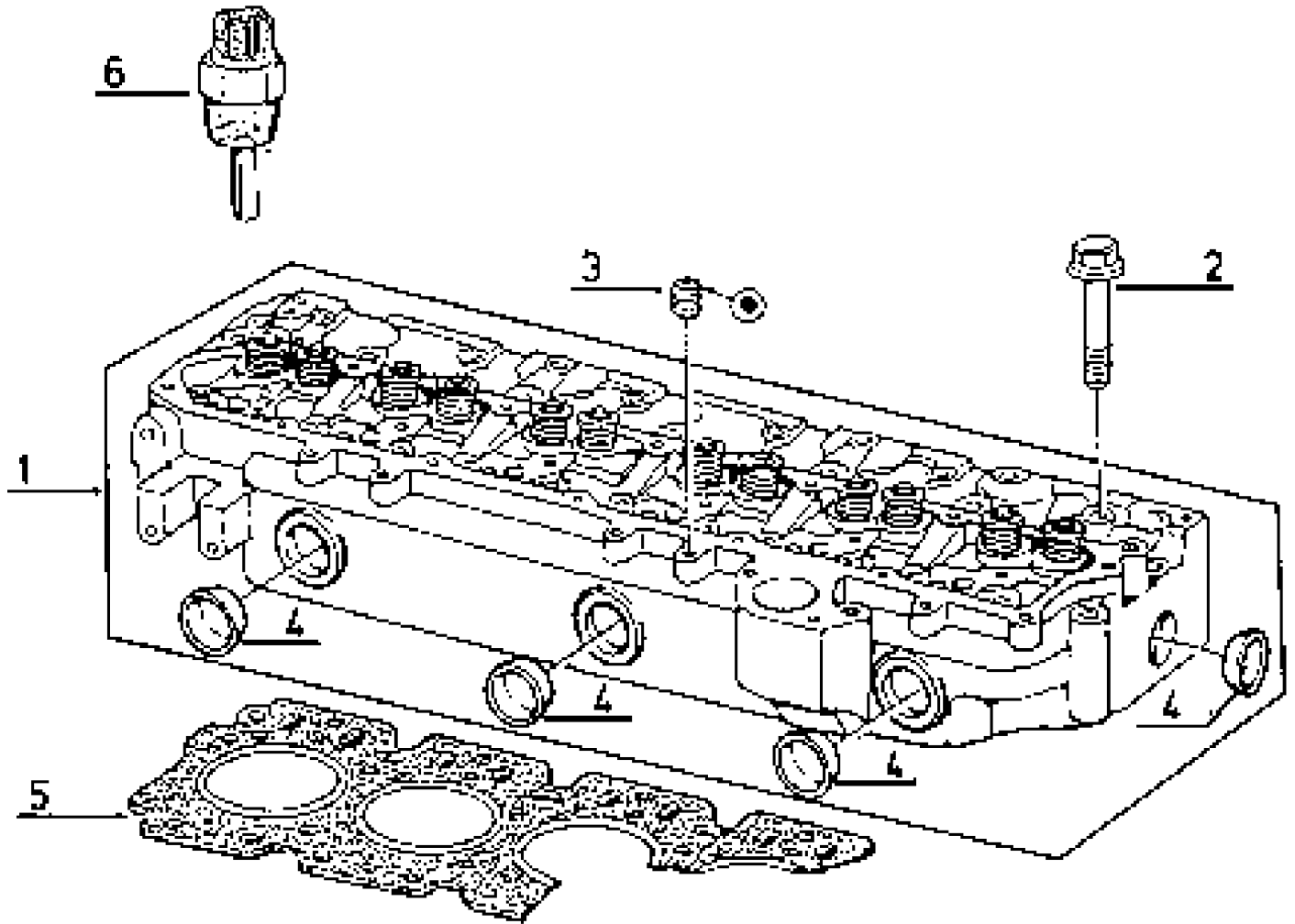

100 CYLINDER HEAD

Pos.	Part No.	Description	Dimension	Quantity	Conditions
1	60 0501 599 7	CYLINDER HEAD		1	
2	60 0501 288 6	SCREW		26	
3	60 0502 144 0	LOCK		1	
4	60 0501 288 3	LOCK		5	
5	60 0501 599 8	CYLINDER HEAD GASKET		1	
6	60 0501 344 2	SENDER UNIT		1	

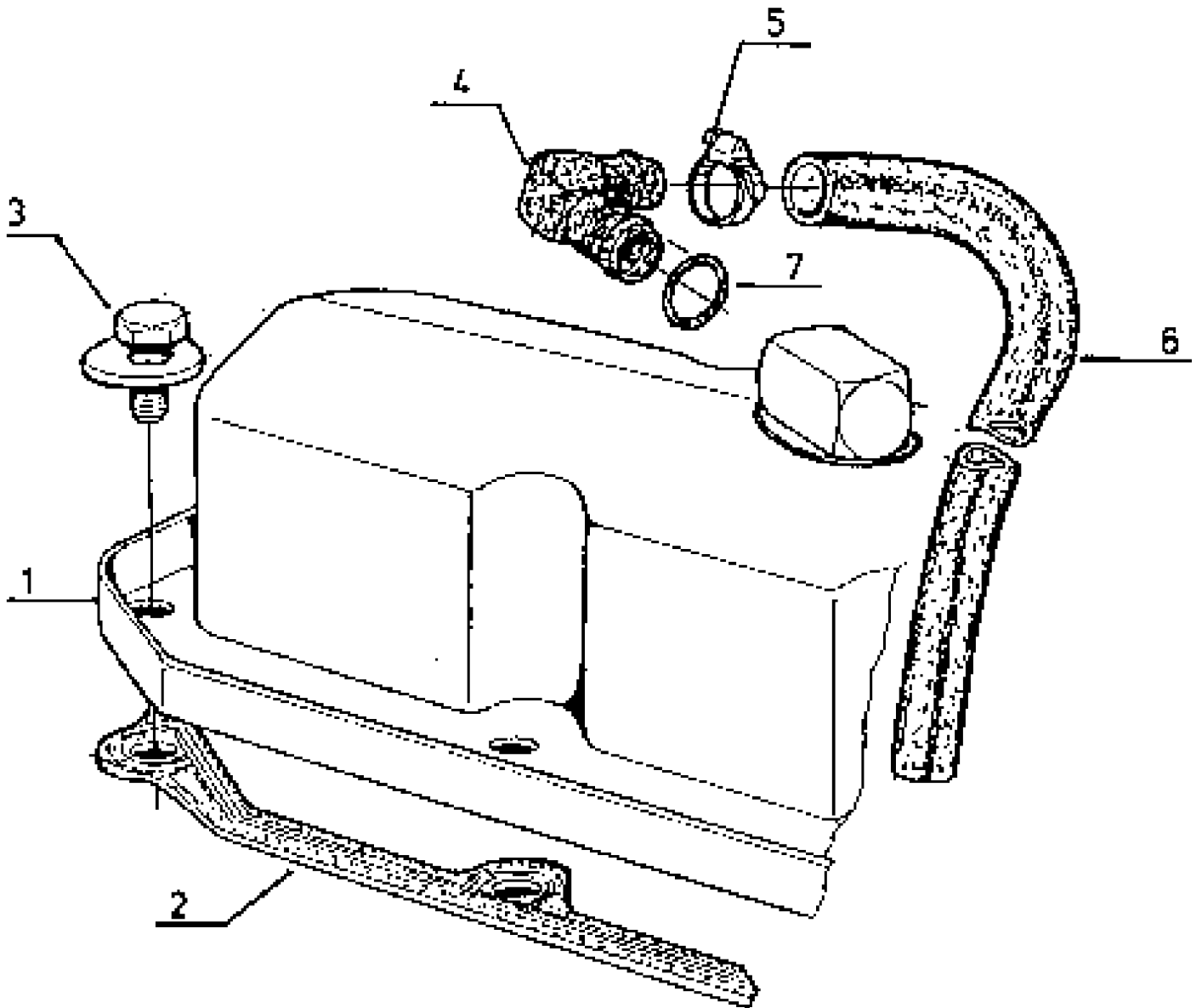

<https://www.ebooklibonline.com>

Hello dear friend!

Thank you very much for reading.

Enter the link into your browser.

The full manual is available for immediate download.

<https://www.ebooklibonline.com>