



A3

ENGINE TIER II

4045 TRT 73 DPS engine

4045 HRT 70 DPS engine

4045 HRT 71 DPS engine

4045 HRT 72 DPS engine

6068 TRT 70 DPS engine

6068 HRT 71 DPS engine

6068 TRT 72 DPS engine

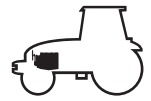

Technology of non-moving parts

Engine block



111msm00

Fig. 2

This can be identified by:

A cavity within which the oil cooler is fitted.

A interchangeable insert ring in the front camshaft bearing.

The locating keyslot in the bearing cap is positioned differently to distinguish between the two bearing shells.

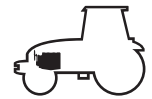

Technology of non-moving parts

Wet liner

The upper flange between the liner and the block incorporates a slope of 0,5.

A range of shims are available for setting liner protrusion (A).

The base of the liner is located by 3 seals:

1. Square shaped neoprene gasket fitted on the sleeve for sealing.

Note: Check location when rebuilding.

2. White O-ring, fitted in the block ensuring vibration stability.

3. Black O-ring, fitted in the block, ensuring vibration stability.

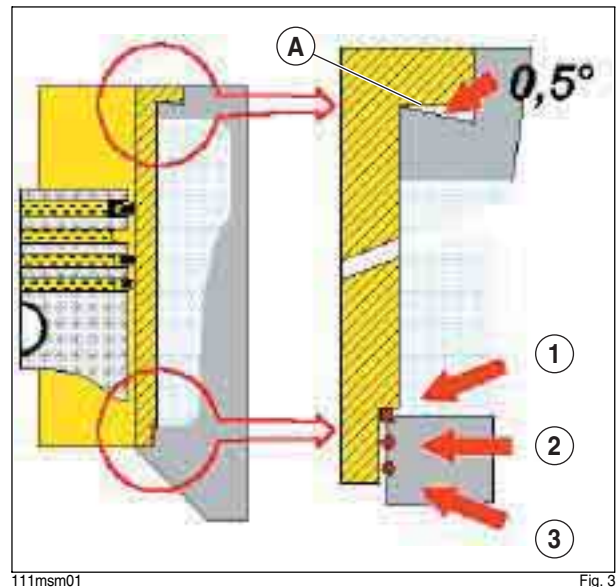

<https://www.ebooklibonline.com>

Hello dear friend!

Thank you very much for reading.

Enter the link into your browser.

The full manual is available for immediate download.

<https://www.ebooklibonline.com>

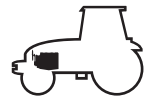

Technology of non-moving parts

Cylinder head

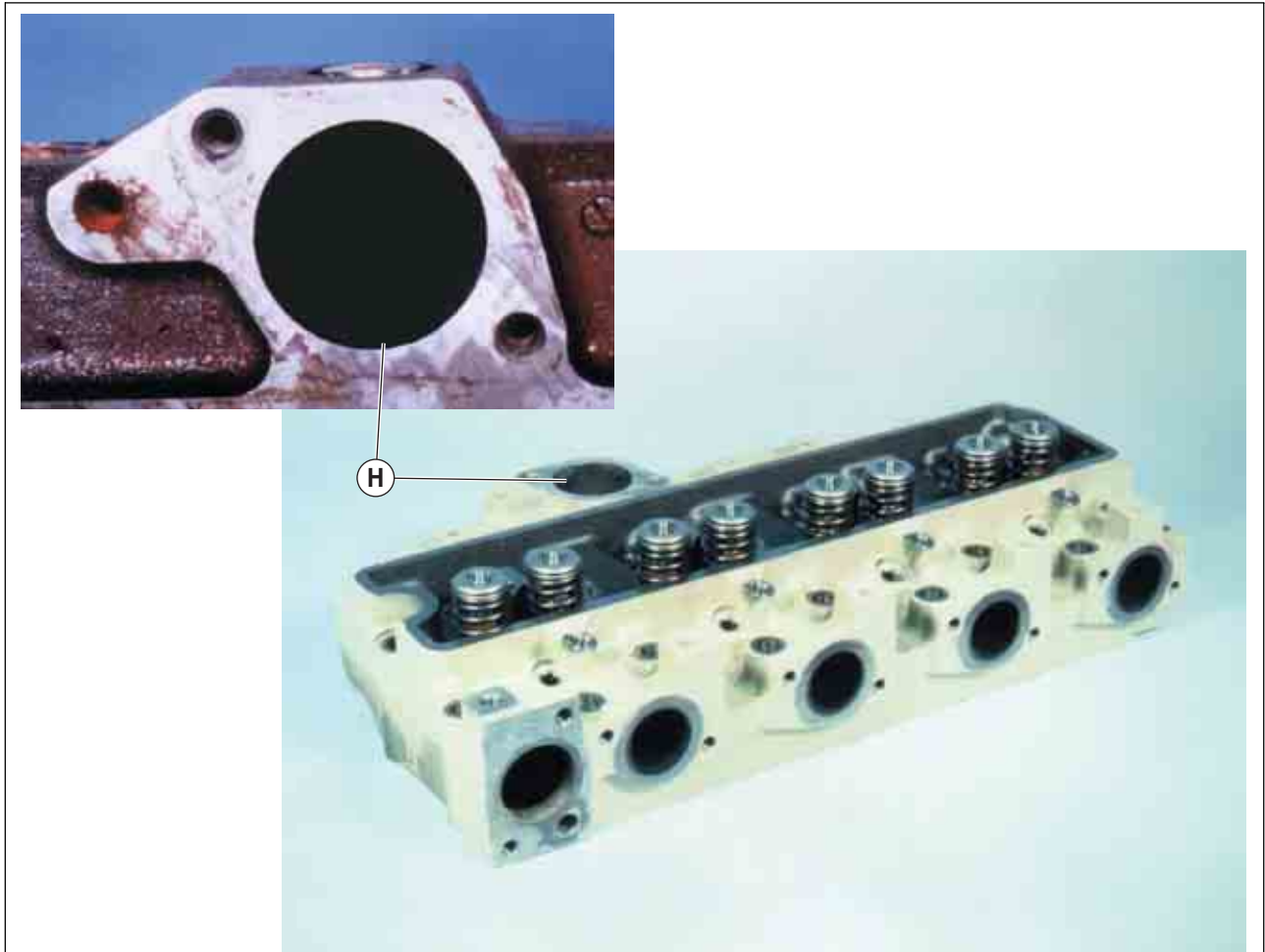

131msm00

Fig. 4

This can be identified by:

The cross-flow design.

The intake ducts are designed to increase turbulence inside the cylinders to enhance the air/fuel mix (SWIRL).

A cast letter (H) in the inlet port identifies the model of cylinder head.

The cylinder head now incorporates a housing for the direct mounting of the thermostat.

The cylinder head gasket is specific.

It has a compressed graphite film on both surfaces.

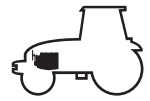

Technology of non-moving parts

Valves

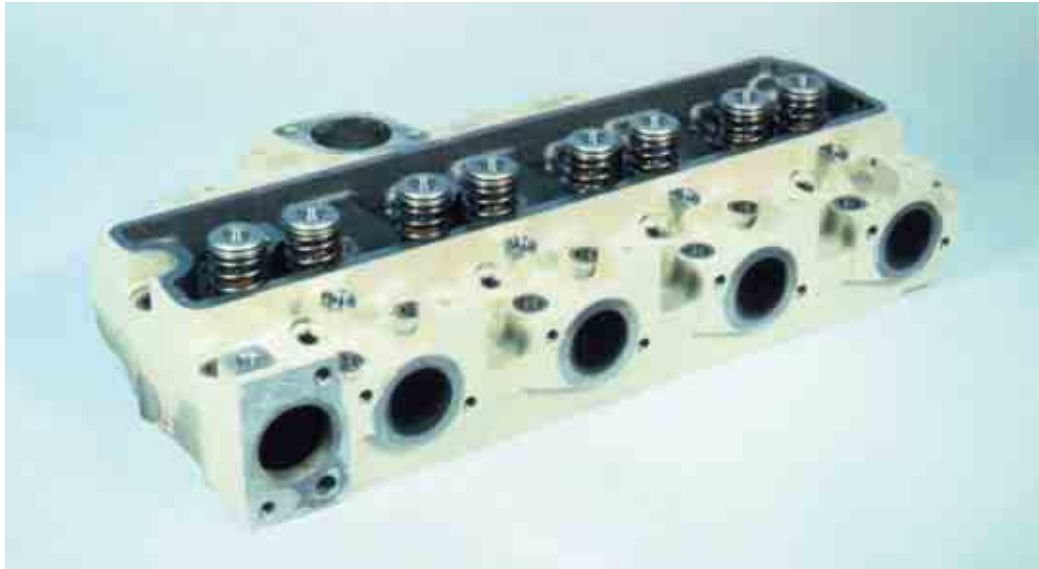

131msm01

Fig. 5

Nomenclature

- A** Collets.
- B** Valve rotator.
- C** Spring.
- D** Umbrella seal.

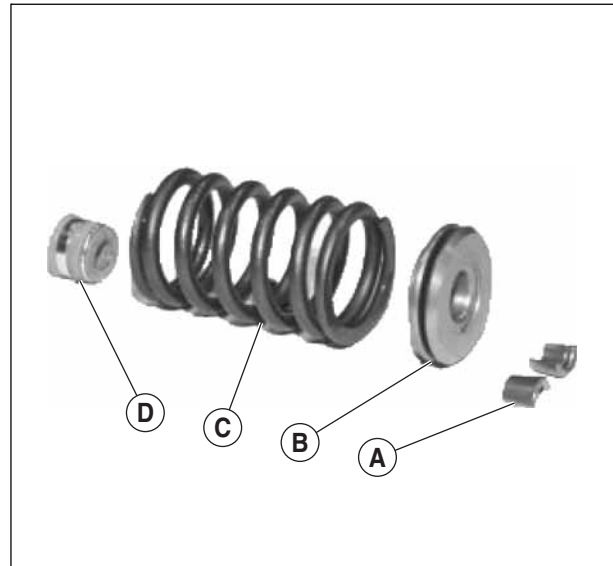

131hsm10

Fig. 6

The valve guides are machined directly in the cylinder head. A helicoidal open groove improves lubrication between the guide and valve. An "umbrella" type seal (D) allows the passage of a controlled quantity of oil to provide lubrication for the valve stem. Each valve is fitted with a rotator (B) ensuring a 3 rotation upon each valve actuation. The contact surface between the valve head and the seat insert is thus always clean.

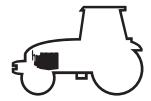

Technology of moving parts

Thrust bearings



131hsm00

Fig. 7

The cushions are of the one-piece type. One is smooth, the other has a groove for lubrication. Several sizes are available for the adjustment of crankshaft end float.

Crankshaft



121msm01

Fig. 8

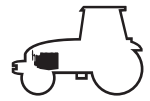

Technology of moving parts

Pistons

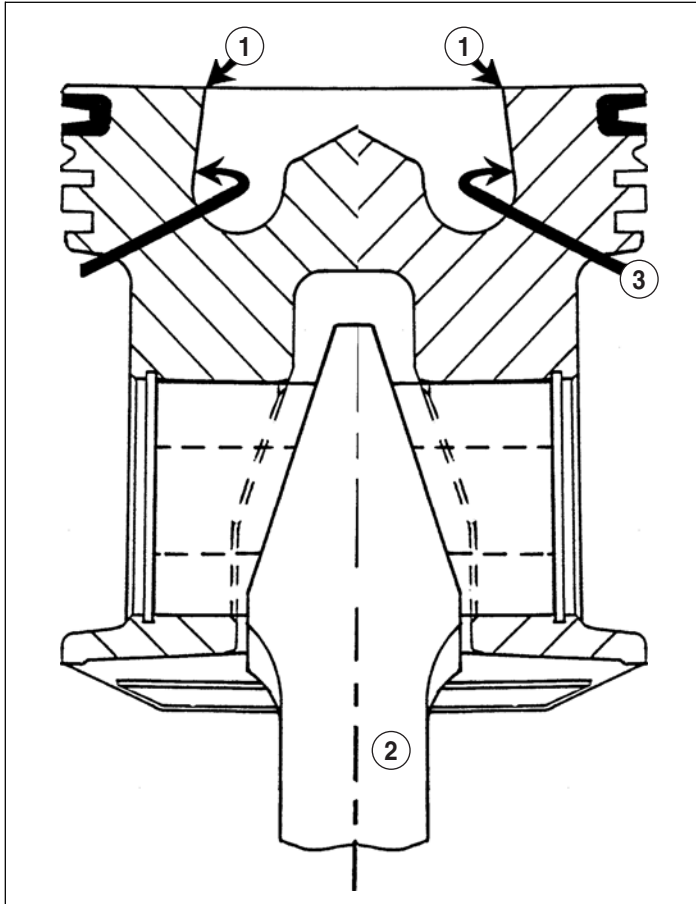

121msm03

Fig. 9

Nomenclature

- 1 Sharp-edged.
- 2 "Snake head" conrod.
- 3 Re-entrant bowl (chamber-in-piston).

Both the pistons and the connecting rods are specific to this type of engine. The combustion chamber, centered in the piston crown, is of the "re-entrant" type. The latter forms a sharp edge with the piston crown and these features give improved combustion. The marking "front" has to be fitted facing the front of the engine.

Connecting rods

The "viper head" connecting rod heads improve the piston pin span. Metric threads are used for the conrod bolts.

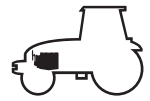

Technology of moving parts

Rings

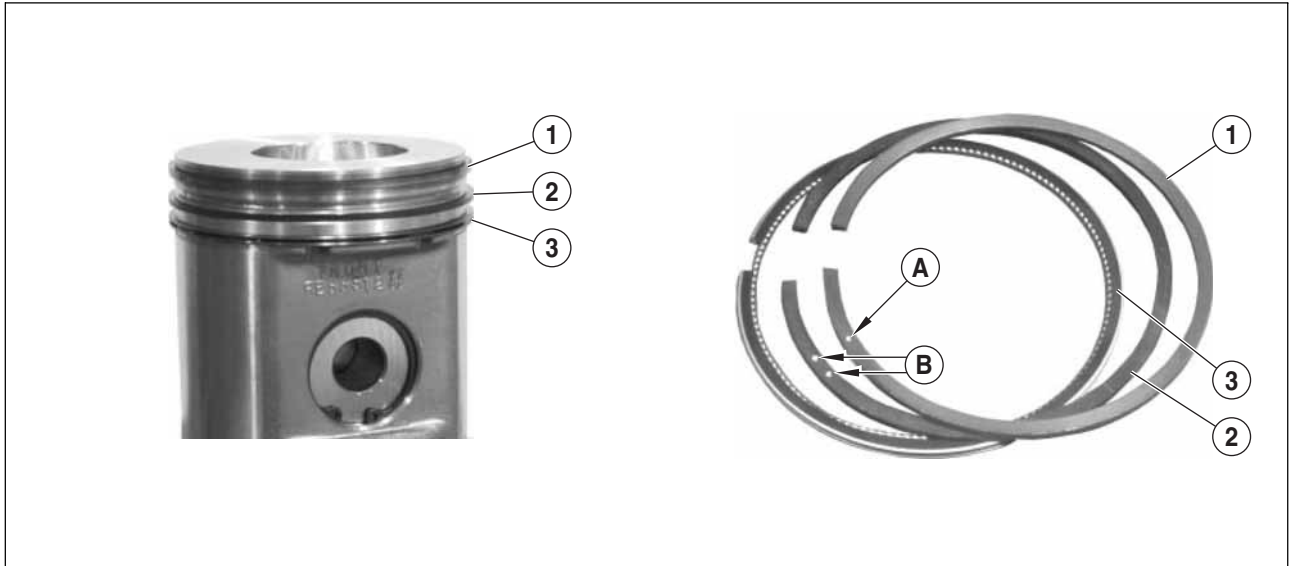

121msm04

Fig. 10

The top compression ring is as close as possible to the top of the piston to reduce waste space. This has necessitated the use of an insert that has better temperature resistance. An accumulation groove between the top compression ring and the compression ring gives the gases a greater expansion volume. The top compression ring thus remains in contact with its bearing surface, reducing the passage of gas to the lower part of the engine.

1. The top compression ring is trapezoid shaped with a contact face of the barrel type. It is marked with a dot (A).
2. The compression ring has a trapezoid cross-section, with a skewed contact face. It is marked with 2 points (B).
3. The oil control ring has a classical shape.

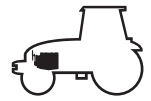

Technology of moving parts

Accessory gear train



121msm05

Fig. 11

Fuel distribution is powered by a helical toothed gear train. Marks engraved on the pinions indicate meshing positions to obtain fuel distribution settings.

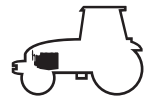

Technology of moving parts

Balance shaft

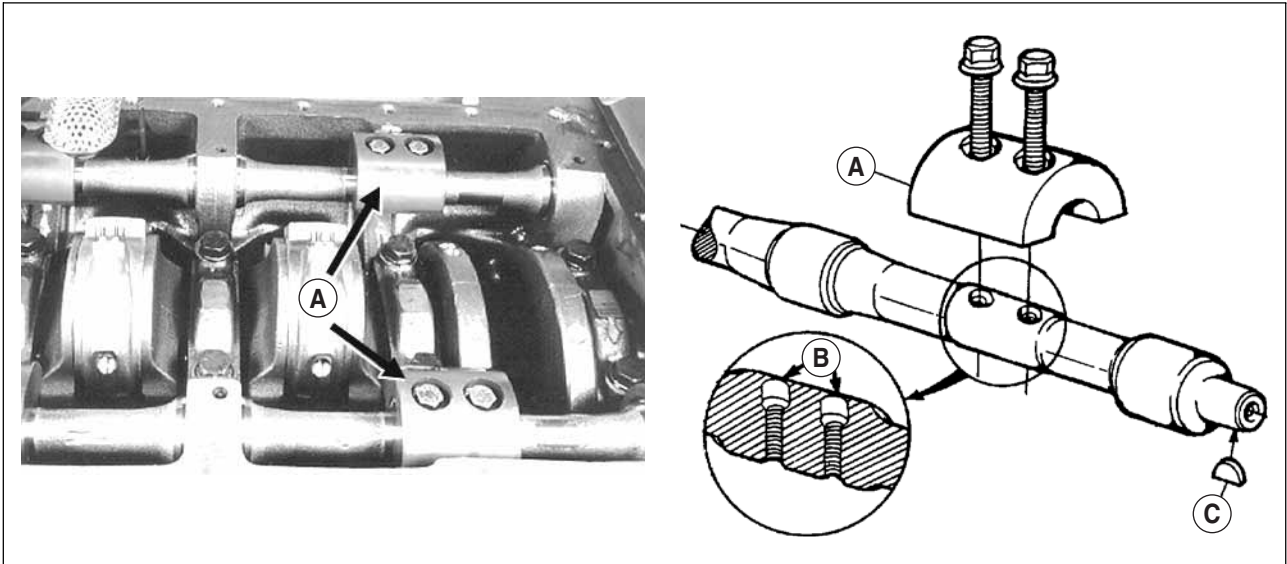

121msm06

Fig. 12

Nomenclature

- A Counterweights.
- B Counter boring.
- C Cotter.

The 4 cylinder engine is equipped with with two balance shafts with detachable counterweights (A) to counter vibrations from the rotating components (bushes are also mounted in bores).

"Damper"

On a 6 cylinder engine, vibration resulting from the crankshaft's torsional response are absorbed by an elastic-hubbed pulley (the crankshaft "Damper").

Nomenclature

- 1 Pulley.
- 2 "Damper".
- 3 Screw.
- 4 Washer.

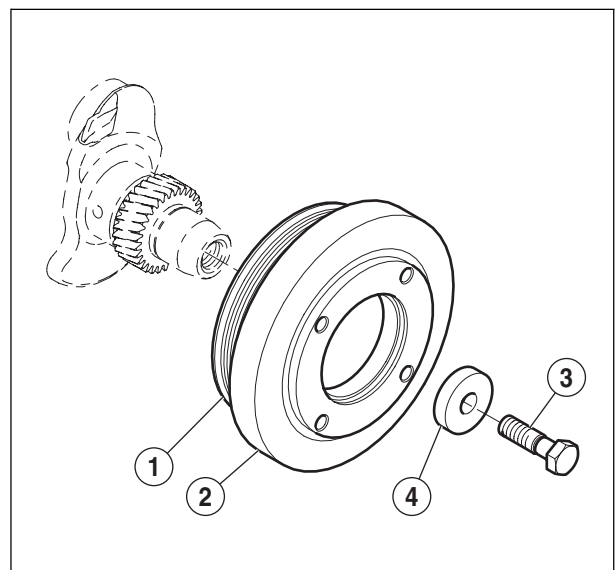

101msm23

Fig. 13

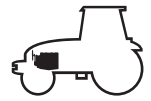

Lubrication

Lubrication system

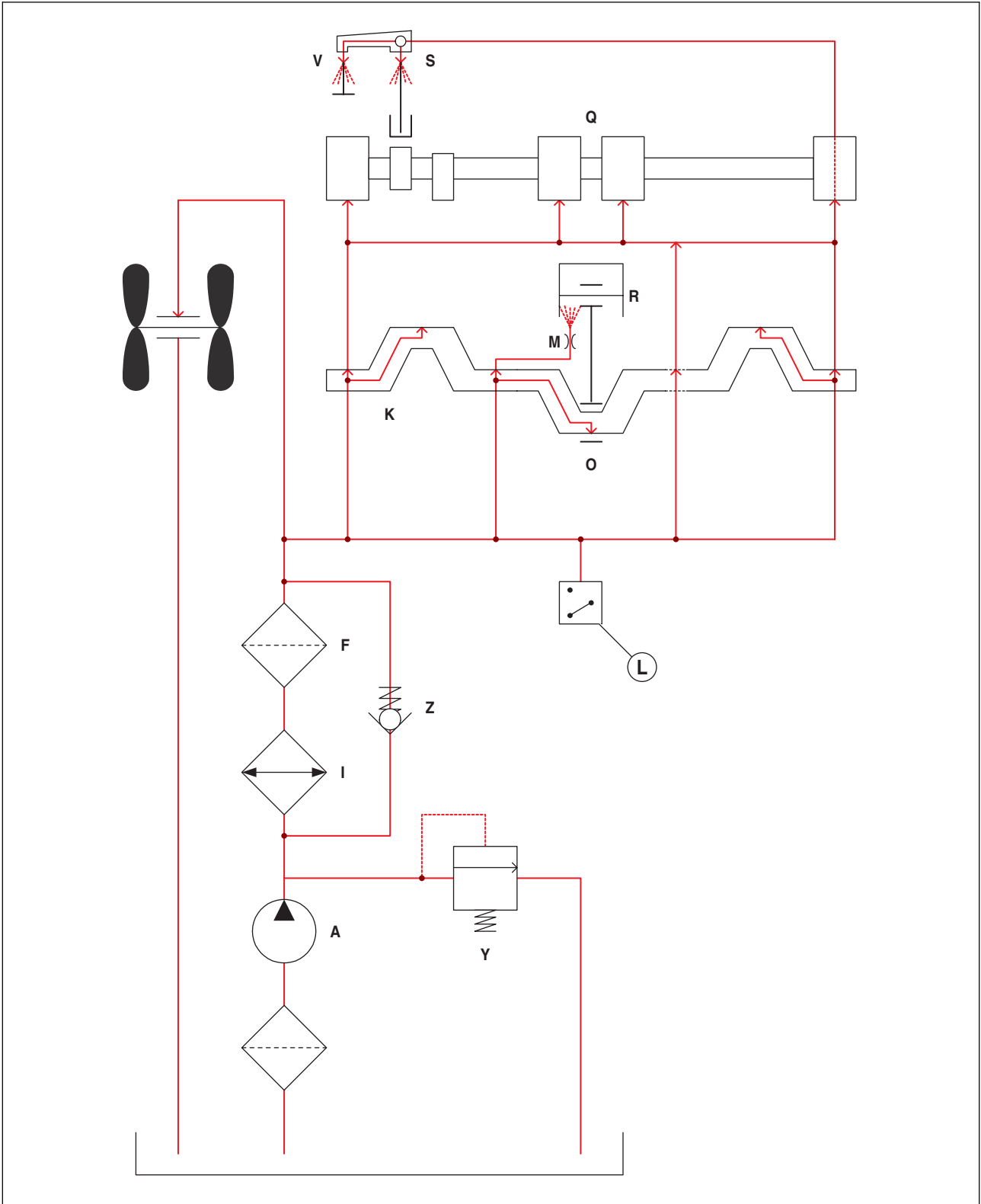

221msm00

Fig. 14

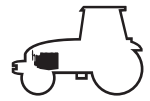

Lubrication

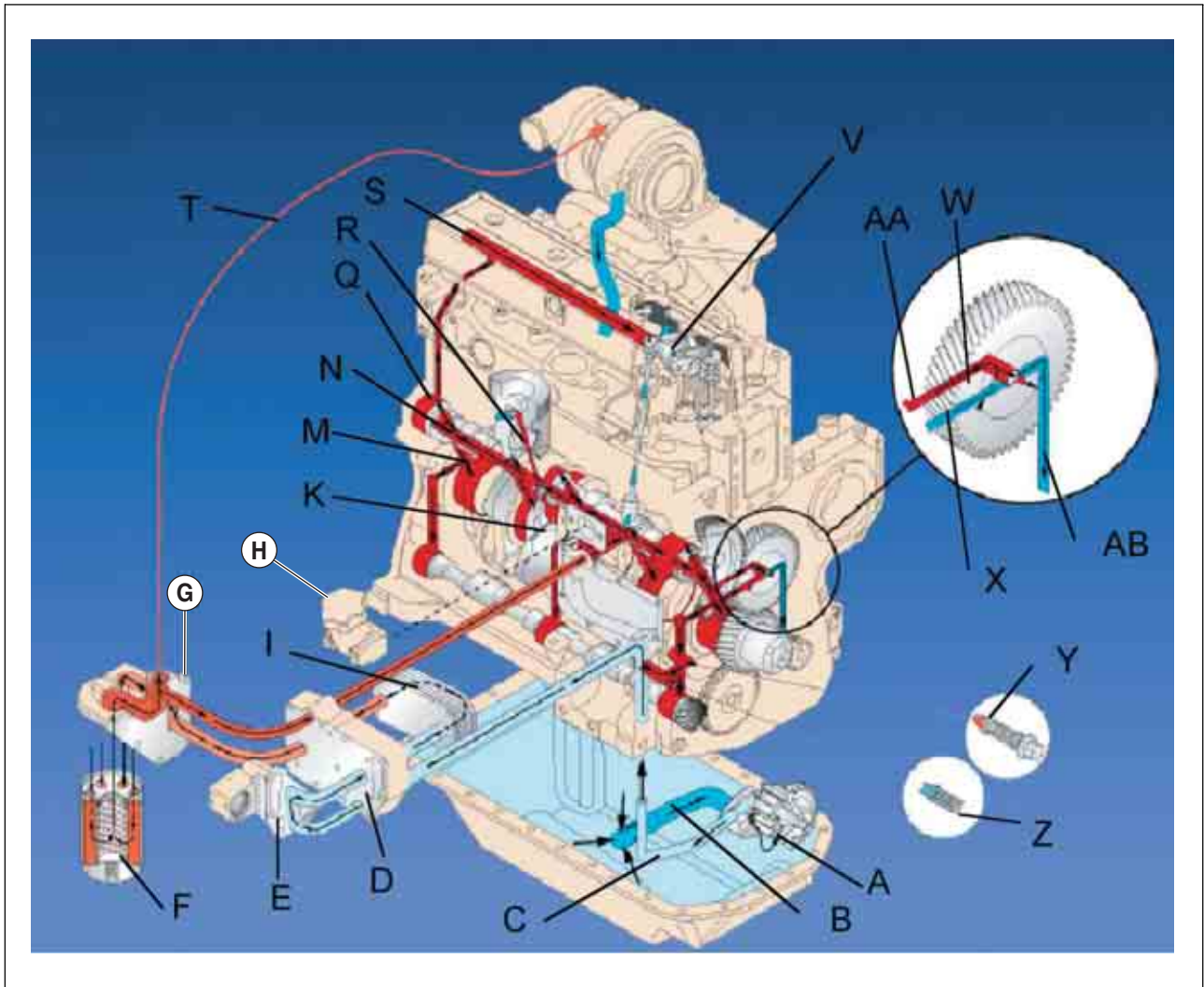

221msm01

Fig. 15

Nomenclature (Fig. 14 and 15)

- | | |
|---------------------------------------|--|
| A Oil pump. | N Main lubrication duct. |
| B Oil suction pipe. | O Connecting rod bearings. |
| C Oil outlet tube. | Q Camshaft bushes. |
| D Oil cooling casing. | R Gudgeon pin and bush. |
| E Coolant passage adaptor. | S Rocker shaft. |
| F Oil filter. | T Turbocharger oil supply duct. |
| G Oil filter manifold/adaptor. | V Rockers. |
| H Oil filler tube. | X Oil feed. |
| I Oil cooler. | Y Oil pressure regulator. |
| K Crankshaft oil galleries. | Z Oil bypass valve. |
| L Pressure switch. | AA Pressurized oil. |
| M Nozzles. | AB Non pressurized oil. |

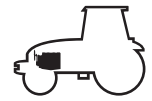

Lubrication

Oil system components

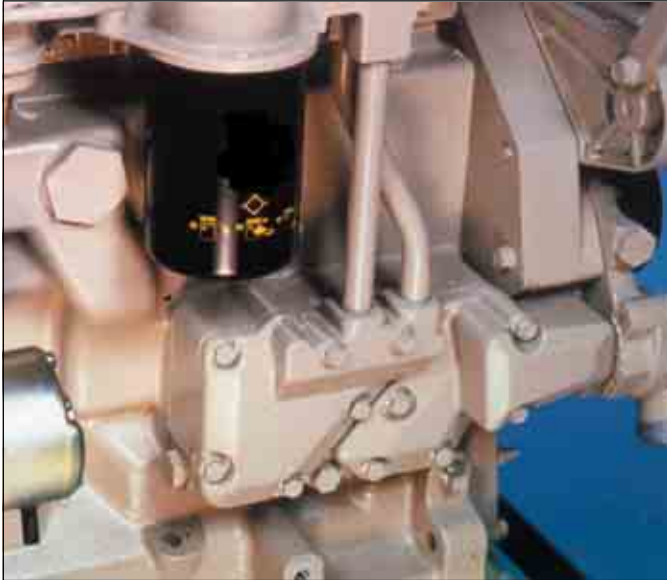

221msm02

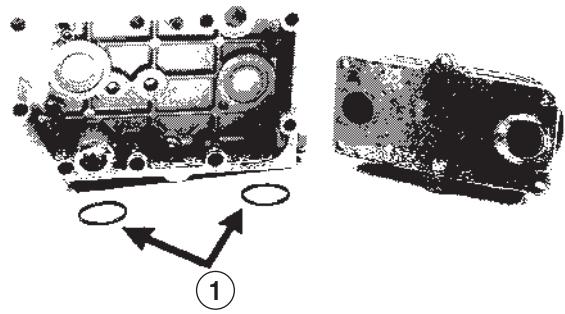

Fig. 16

Nomenclature

- 1 Seal.

The oil cooler is an exchanger featuring 7 plates inserted between the oil pump and the filter.

It speeds up oil warm-up on engine start thanks to the flow of water from the cylinder head pumped by the water pump.

It then regulates and evens out the temperature. It is fitted in a cavity of the cylinder block.

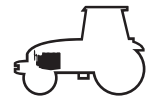

Lubrication

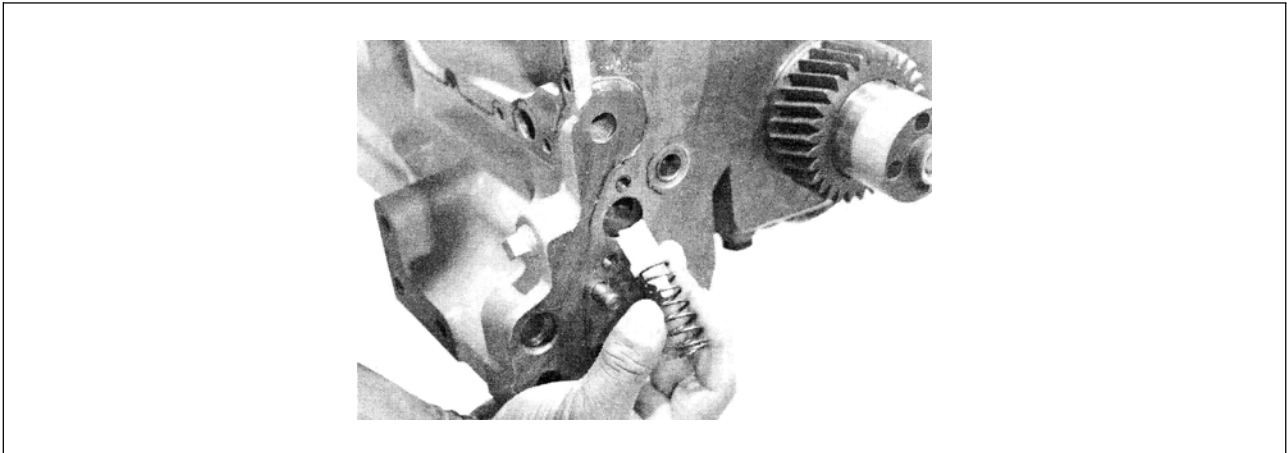

221msm03

Fig. 17

In very cold conditions, the by-pass valve is designed to bypass part of the oil directly to the primary gallery, by short-circuiting the filter and cooler for a short time. This valve requires no adjustment or maintenance.

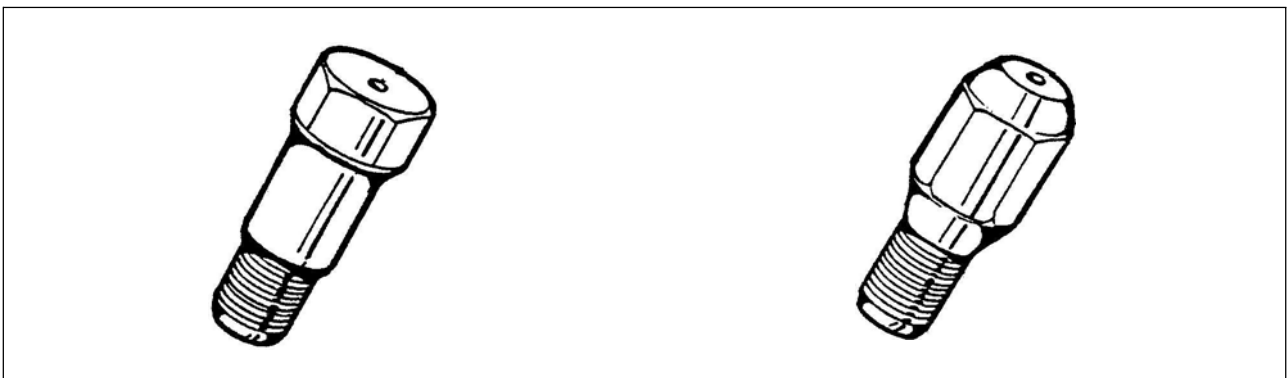

221msm04

Fig. 18

The oil spray nozzles screwed to the galleries provide lubrication to the liners and gudgeon pins as well as cooling for the bases of the pistons, with a flow of around 1,4 l/m.

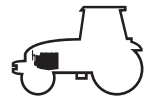

Cooling

Cooling system

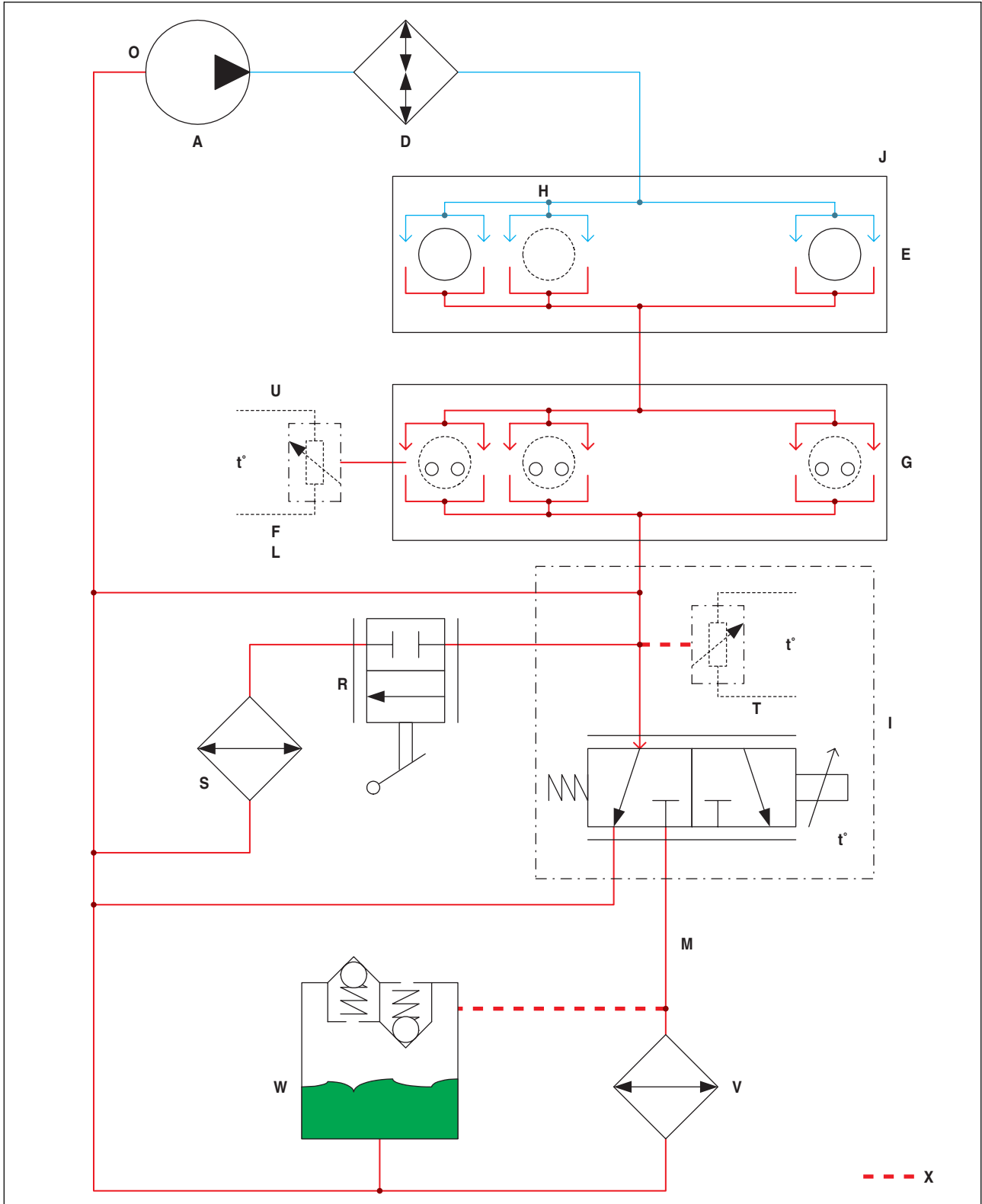

221msm05

Fig. 19

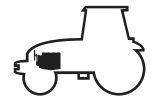

Cooling

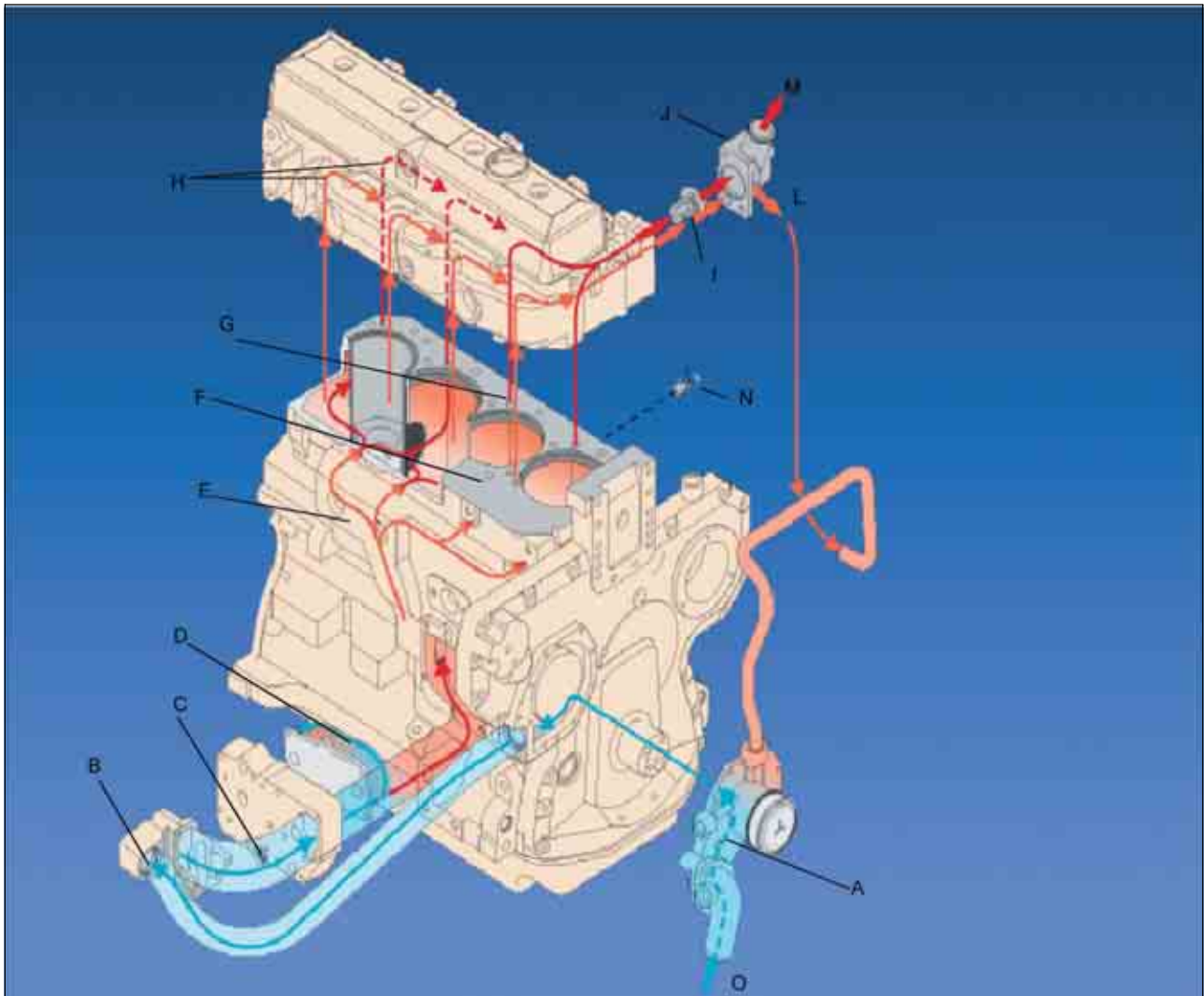

251msm00

Fig. 20

Nomenclature (Fig. 19 and 20)

- | | |
|---|--|
| A Water pump. | N Drain plug. |
| B Coolant passage adaptor. | O Water pump suction side. |
| C Oil cooler drain plug. | P High temperature cooling fluid. |
| D Oil cooler plates. | Q Low temperature cooling fluid. |
| E Cooling fluid passage. | R Cabin heater valve. |
| F Cooling fluid envelope. | S Cabin heater radiator. |
| G Passages in the upper part of the block. | T Engine management thermistance. |
| H Passages. | U Instrument panel thermistance. |
| I Thermostat. | V Heat exchanger. |
| J Water manifold/thermostat housing. | W Expansion tank. |
| L Bypass circuit. | X Depending on installation. |
| M Towards the radiator upper tank. | |

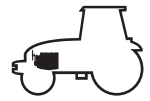

Cooling

Components of cooling system

The thermostat is incorporated within the cylinder head by means of the water housing. Part of the water flow is diverted to the water pump via a steel tube. The temperature is regulated between 82 and 95°C.

Nomenclature

- A** Coolant temperature probe.

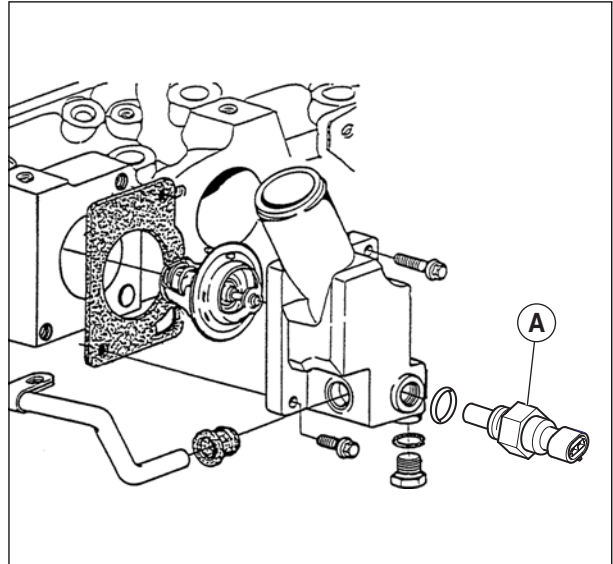

251msm01

Fig. 21

N.B.: During filling, with the engine idling, purge the circuit by loosening the temperature probe (A) (Fig. 22).

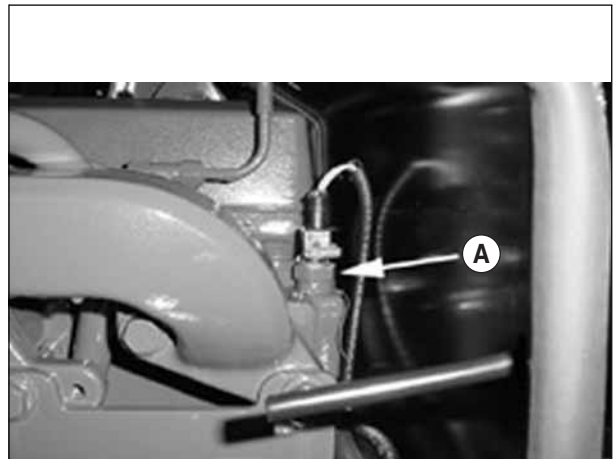

251msm02

Fig. 22

The water pump is fitted in the distribution casing and uses the cavity in the cover as the pump body.



251msm03

Fig. 23

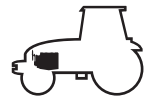

Cooling

The viscous clutch has 3 main parts:

Drive part = Rotor (1) + Plate (2) fitted with annular grooves.

Driven part = Hub (6) for the fan + Body (7) fitted with annular grooves.

Regulator part = Thermostatic spring (3) + Valve (4) that controls the flow of coupling fluid.

This silicon-based viscous fluid is stored in tank (5).

When the temperature of the air flowing through the radiator reaches a predetermined level the thermostatic spring operates the valve which opens the orifice. By centrifugal force, the liquid travels towards the annular grooves in the hub and the body. The torque is transmitted by the internal friction of the highly viscous liquid and its adhesion to the walls. The fan is thus powered and the cooling is improved.

Nomenclature

- 1 Shaft.
- 2 Plate.
- 3 Thermostatic spring.
- 4 Valve.
- 5 Tank.
- 6 Hub.
- 7 Body.

Warning for the storage of Visco.

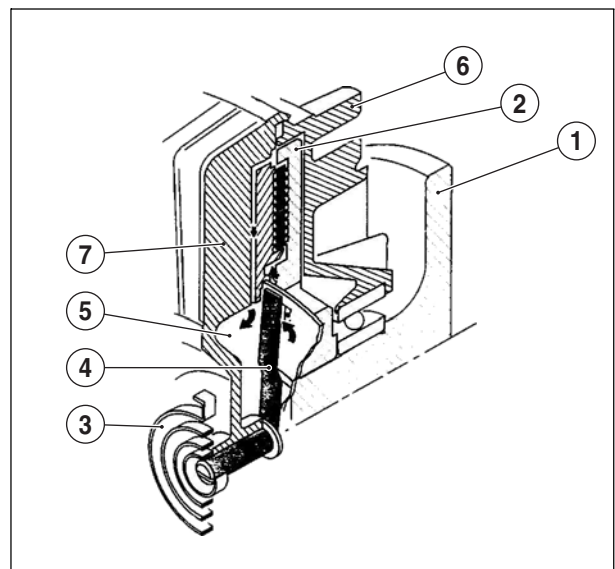

253msm00

Fig. 24



Suggest:

For more complete manuals. Please go to the home page.

<https://www.ebooklibonline.com>

If the above button click is invalid. Please download this document first, and then click the above link to download the complete manual.

Thank you so much for reading

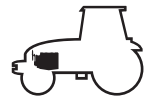

Air

Nomenclature

A	Filter.	H	Pre-heat flange.
B	Filter blockage thermal switch.	I	Pre-heat relay.
C	Pneumatic compressor.	J	Instrument panel.
D	Turbo.	K	Intake/exhaust.
E	Intercooler (depending on assembly).	L	Dust rebreathing.
F	Intercooler blockage thermal switch.	M	Exhaust.
G	Air temperature thermistance.		

Pre-heating

Both the pre-heating and the illumination of the instrument panel warning light are controlled by the engine ECU.

Dust rebreathing

Dust rebreathing is achieved by a duct subject to a venturi effect between the exhaust pipe and the air filter.



Tightening torques

Front chassis / engine link

1. 35 daN.m.

Engine/transmission link

2. 73,5 daN.m + Frenetanch (242).
3. 28 daN.m + Frenetanch (242).
4. Guide pin.

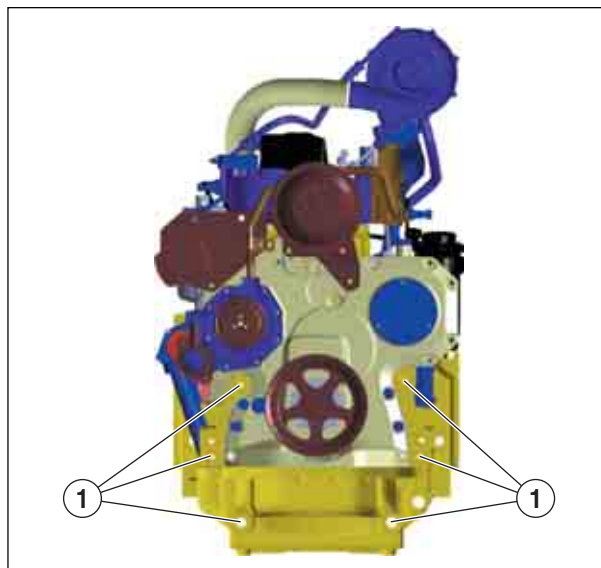

101msm16

Fig. 26

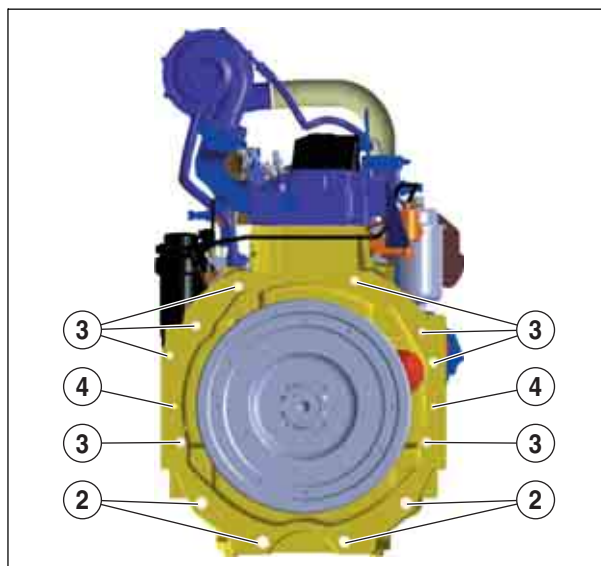

101msm17

Fig. 27

<https://www.ebooklibonline.com>

Hello dear friend!

Thank you very much for reading.

Enter the link into your browser.

The full manual is available for immediate download.

<https://www.ebooklibonline.com>