

010 COMPLETE ENGINE

Pos.	Part No.	Description	Dimension	Quantity	Conditions
1	77 0005 371 3	ENGINE		1	1)
-		<i>Please order additionally!</i>			
	77 0001 693 5	SCREW		8,000	
	77 0005 382 8	TORSION DAMPER		1,000	
	77 0005 382 9	NUT		1,000	
	77 0005 383 0	STUD BOLT		1,000	
	77 0005 383 2	SHAFT		1,000	
1	77 0005 371 4	ENGINE		1	2)
-		<i>Please order additionally!</i>			
	77 0001 693 5	SCREW		8,000	
	77 0005 382 8	TORSION DAMPER		1,000	
	77 0005 382 9	NUT		1,000	
	77 0005 383 0	STUD BOLT		1,000	
	77 0005 383 2	SHAFT		1,000	
1	77 0005 371 3	ENGINE		1	3)
-		<i>Please order additionally!</i>			
	77 0001 693 5	SCREW		8,000	
	77 0005 277 4	TORSION DAMPER		1,000	
1	77 0005 371 4	ENGINE		1	4)
-		<i>Please order additionally!</i>			
	77 0001 693 5	SCREW		8,000	
	77 0005 277 4	TORSION DAMPER		1,000	

1) Equipment

Homologationtype OK0031 MECHANICAL REV.
+ 4032
->PL.10.1.03.A

2) Equipment

Homologationtype OK0031 MECHANICAL REV.
+ 4042
->PL.10.1.03.B

3) Equipment

Homologationtype OK0033 REVERSHIFT
+ 4032
->PL.10.1.03.A

4) Equipment

Homologationtype OK0033 REVERSHIFT
+ 4042
->PL.10.1.03.B

PL 13.1.20.A

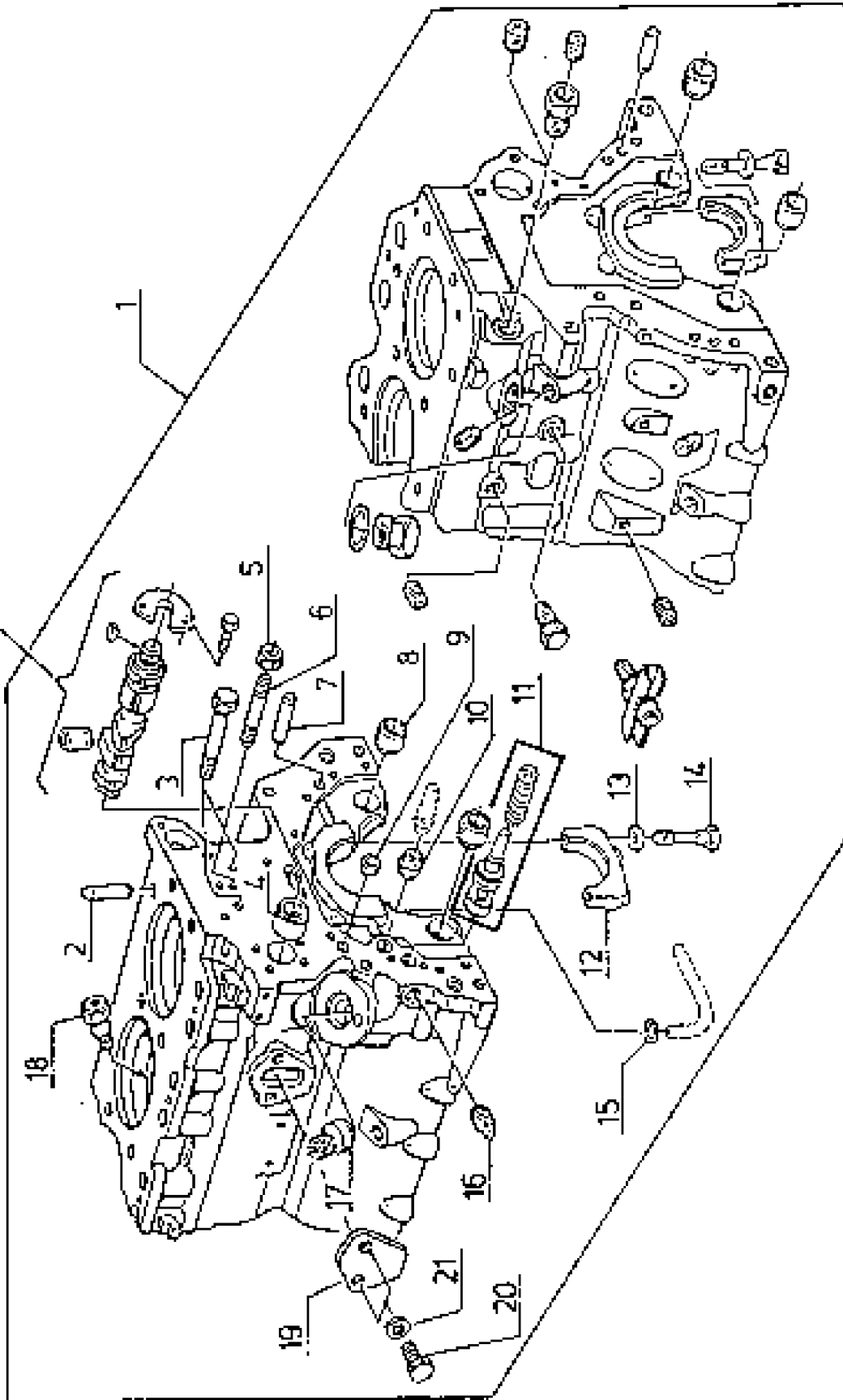

<https://www.ebooklibonline.com>

Hello dear friend!

Thank you very much for reading.

Enter the link into your browser.

The full manual is available for immediate download.

<https://www.ebooklibonline.com>

100 CRANKCASE 1)

Pos.	Part No.	Description	Dimension	Quantity	Conditions
1	FA-CONSIGN ES	Consignes - CS		1	
-		<i>Please order!</i> 60 0502 911 0 <i>SHORT BLOCK</i>		1,000	
2	60 0501 317 4	CENTRING PIN		4	
3	60 0501 319 5	SCREW		2	2)
4	60 0501 294 1	BEARING		1	
5	60 0501 321 4	NUT		1	
6	60 0501 319 3	STUD BOLT		1	
7	60 0501 319 6	CENTRING PIN		2	
8	60 0502 187 2	SCREW		6	
9	60 0501 319 8	BLANKING COVER		1	
10	60 0501 319 9	BUSHING		1	
11	60 0501 402 9	VALVE		1	
12	60 0501 320 4	COVER		4	
13	60 0501 320 5	WASHER		8	
14	60 0501 320 6	SCREW		8	
15	60 0501 320 3	O-RING		1	
16	60 0501 320 2	LOCK		1	
17	60 0501 319 1	GREASE NIPPLE		1	
18	60 0501 318 9	SCREW		4	
19	60 0501 365 6	PLATE		1	
20	60 0501 308 2	SCREW		2	3)
21	60 0501 308 3	WASHER		2	4)
1)	Homologationtype		+ 4032		
2)	Remarks		3/8"x2-1/4"		
3)	Remarks		5/16x3/4"		
4)	Remarks		11/32"x3/4"		

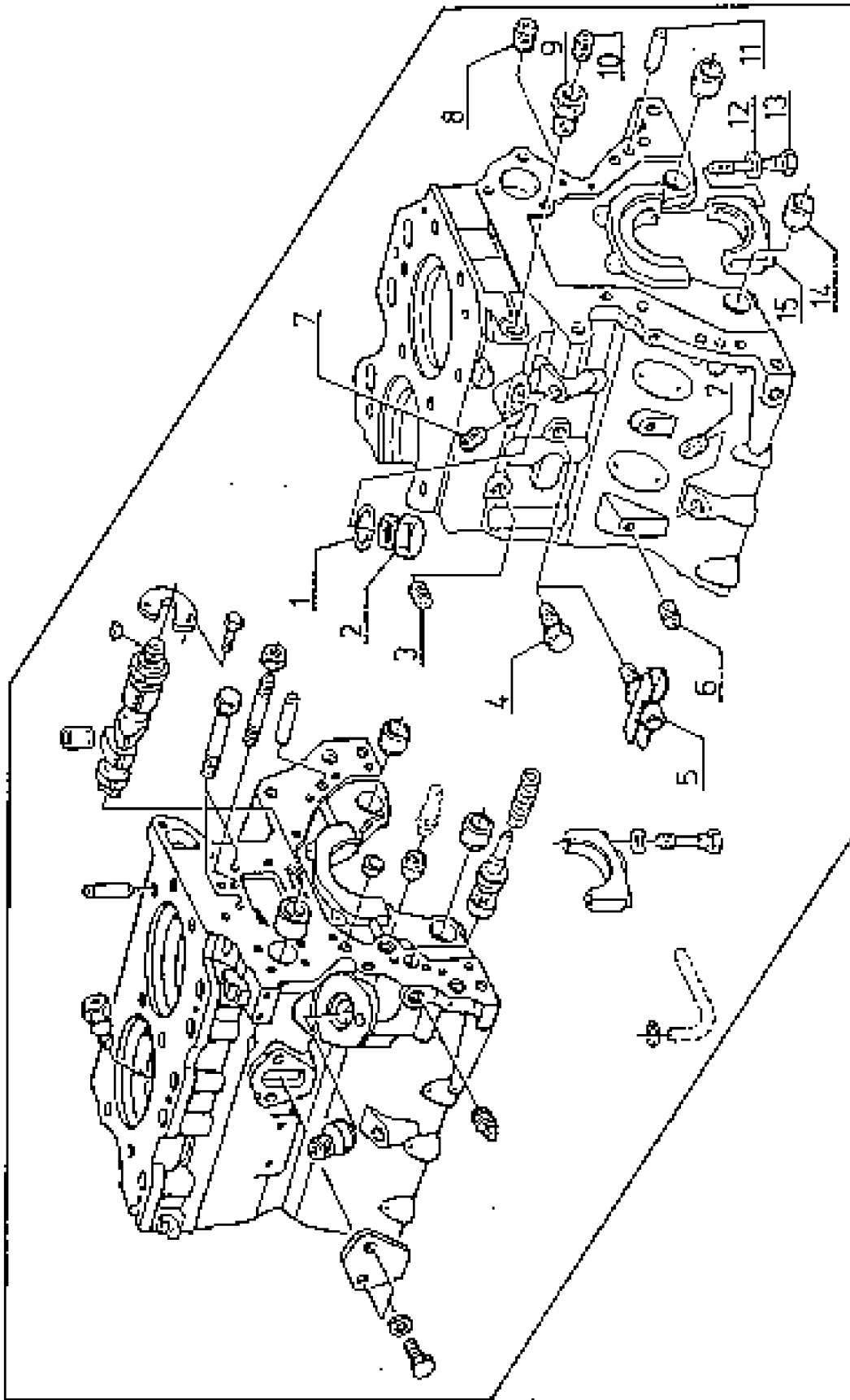

100 CRANKCASE 1)

Pos.	Part No.	Description	Dimension	Quantity	Conditions
1	60 0502 339 4	O-RING		1	
2	60 0502 339 5	LOCK		1	
3	60 0501 320 8	LOCK		1	
4	60 0501 320 9	LOCK		1	
5	60 0501 320 7	VALVE		1	
6	60 0502 144 0	LOCK		5	
7	60 0501 321 9	LOCK		2	
8	60 0501 321 1	LOCK		1	
9	60 0501 321 7	GREASE NIPPLE		1	
10	60 0501 321 8	LOCK		1	
11	60 0501 317 4	CENTRING PIN		4	
12	60 0501 320 5	WASHER		2	
13	60 0501 320 6	SCREW		2	
14	60 0501 287 2	BEARING		6	
15	60 0501 321 2	COVER		1	
1) Homologationtype			+ 4032		

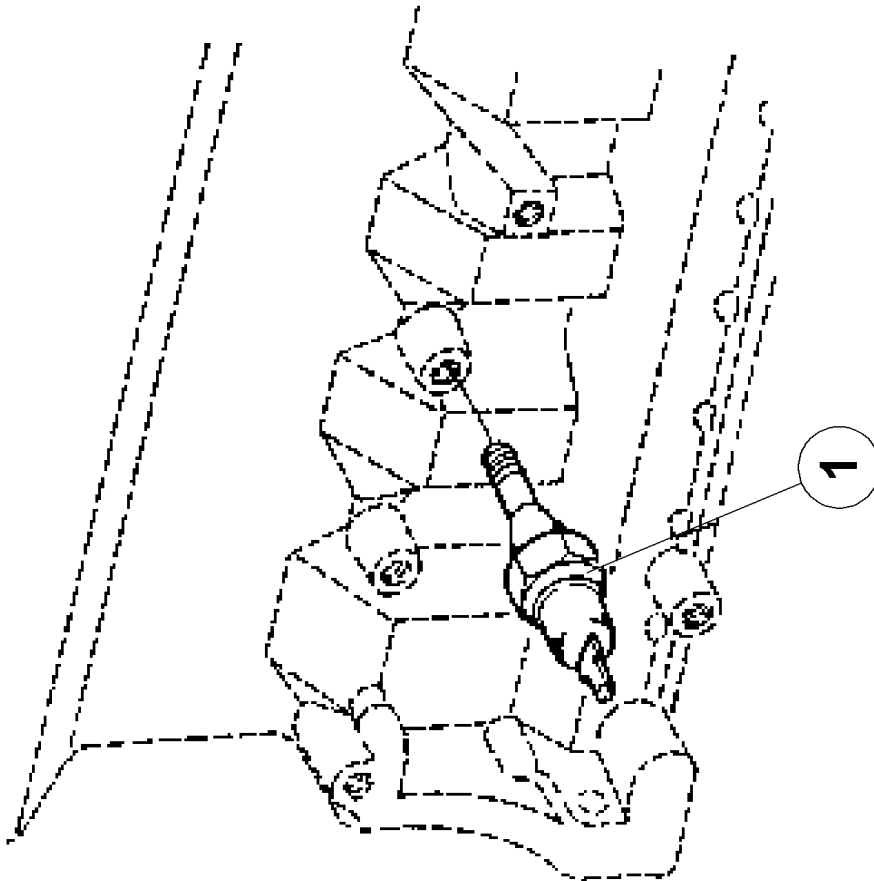

100 CRANKCASE 1)

Pos.	Part No.	Description	Dimension	Quantity	Conditions
1	60 0501 342 7	TRANSMITTER		1	
1)	Homologationtype		+ 4032		

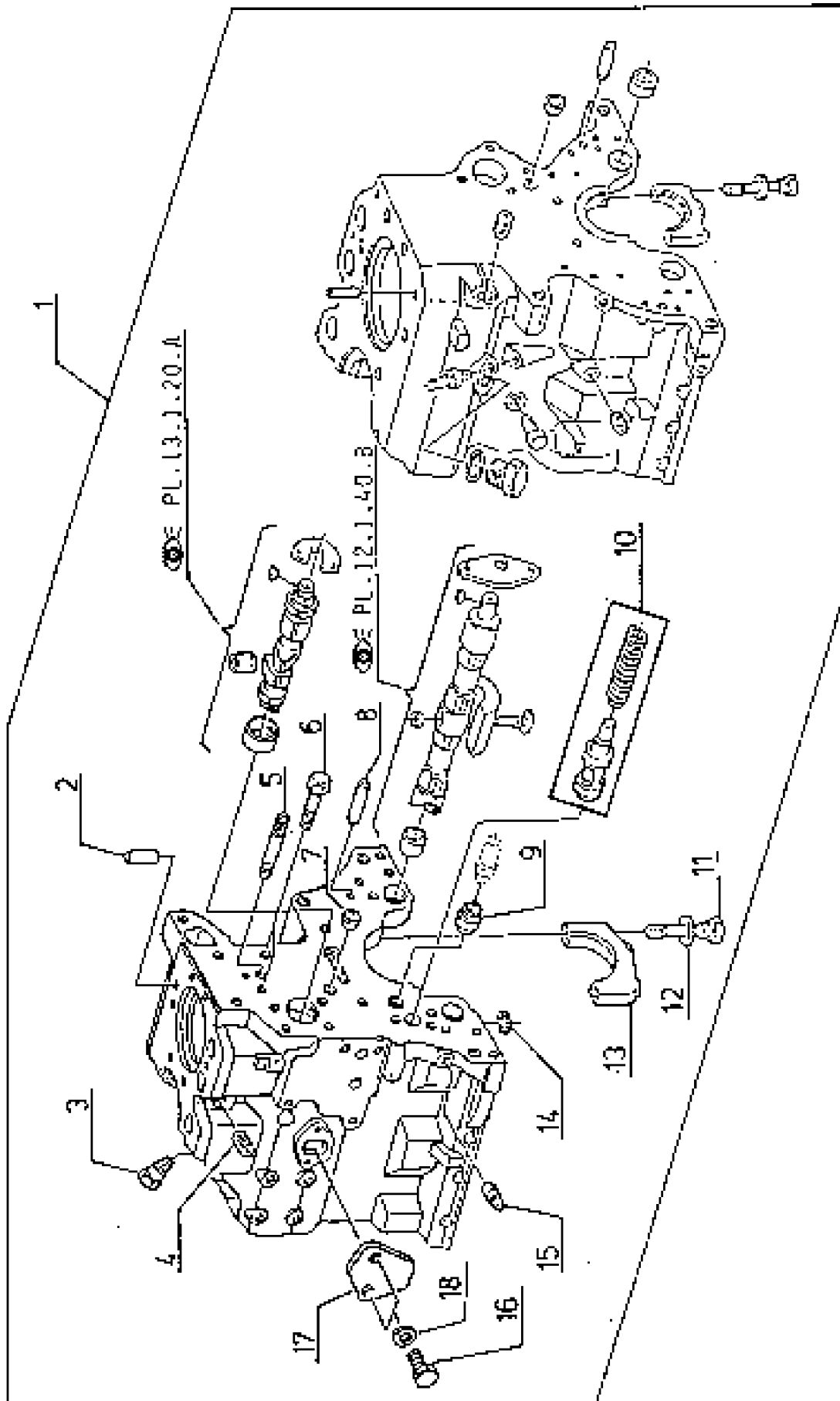

100 CRANKCASE 1)

Pos.	Part No.	Description	Dimension	Quantity	Conditions
1	FA-CONSIGNES	Consignes - CS		1	
-		<i>Please order!</i> 60 0502 911 1 <i>SHORT BLOCK</i>		1,000	
2	60 0501 317 4	CENTRING PIN		4	
3	60 0501 318 9	SCREW		4	
4	60 0501 321 9	LOCK		1	
5	60 0501 319 3	STUD BOLT		1	
6	60 0501 319 5	SCREW		2	2)
7	60 0501 319 8	BLANKING COVER		1	
8	60 0501 319 6	CENTRING PIN		2	
9	60 0501 319 9	BUSHING		1	
10	60 0501 402 9	VALVE		1	
11	60 0501 320 6	SCREW		8	
12	60 0501 320 5	WASHER		8	
13	60 0501 320 4	COVER		4	
14	60 0501 320 3	O-RING		1	
15	60 0501 320 2	LOCK		1	
16	60 0501 308 2	SCREW		2	3)
17	60 0501 365 6	PLATE		1	
18	60 0501 308 3	WASHER		2	4)

1)	Homologationtype	+ 4042
2)	Remarks	3/8"x2-1/4"
3)	Remarks	5/16"x3/4"
4)	Remarks	11/32"x5/8"

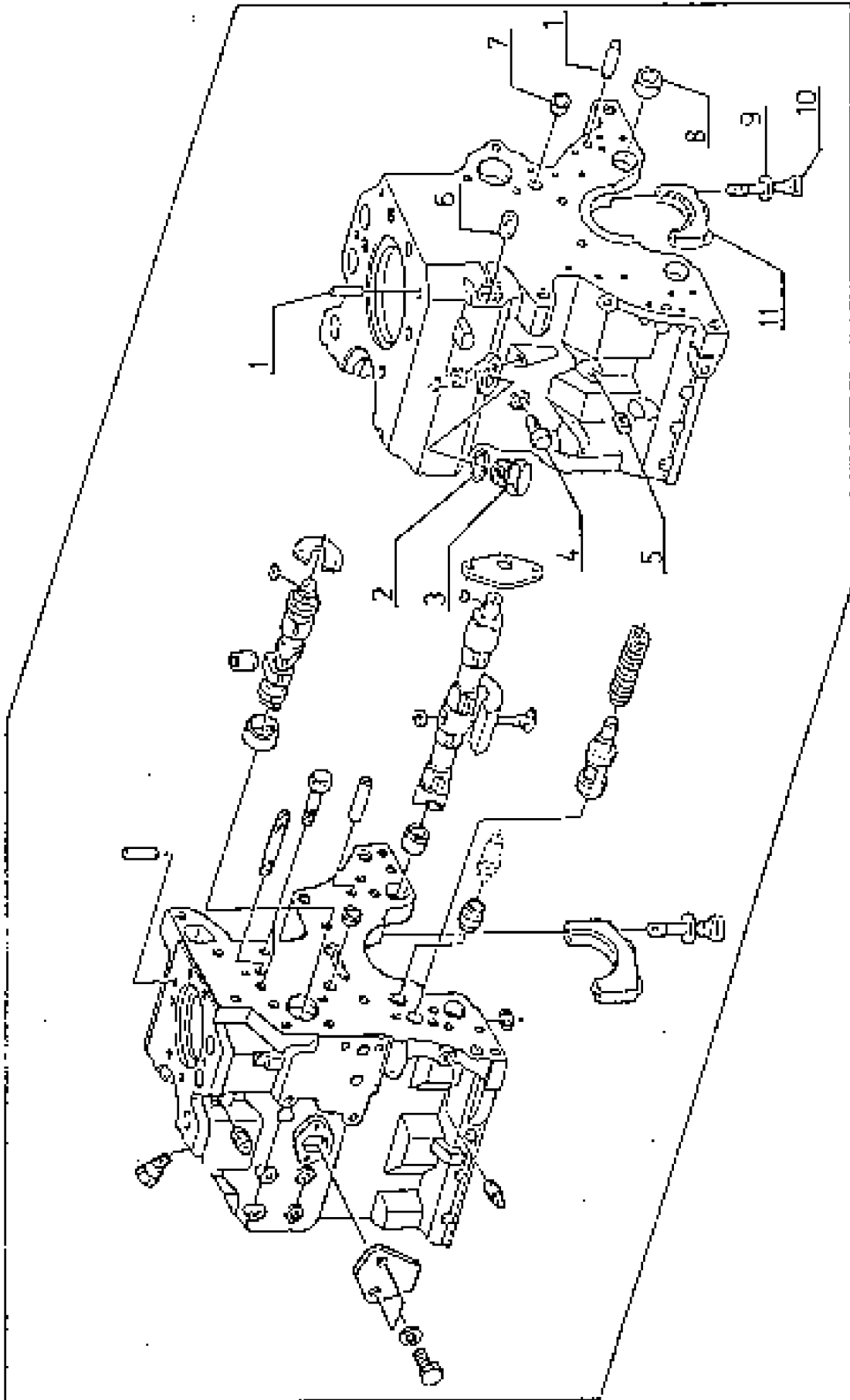

100 CRANKCASE 1)

Pos.	Part No.	Description	Dimension	Quantity	Conditions
1	60 0501 317 4	CENTRING PIN		4	
2	60 0502 339 4	O-RING		1	
3	60 0502 339 5	LOCK		1	
4	60 0501 320 9	LOCK		1	
5	60 0502 144 0	LOCK		5	
6	60 0501 321 1	LOCK		1	
7	60 0501 319 8	BLANKING COVER		2	
8	60 0501 287 2	BEARING		6	
9	60 0501 320 5	WASHER		2	
10	60 0501 320 6	SCREW		2	
11	60 0501 321 2	COVER		1	
<hr/>					
1)	Homologationtype		+ 4042		

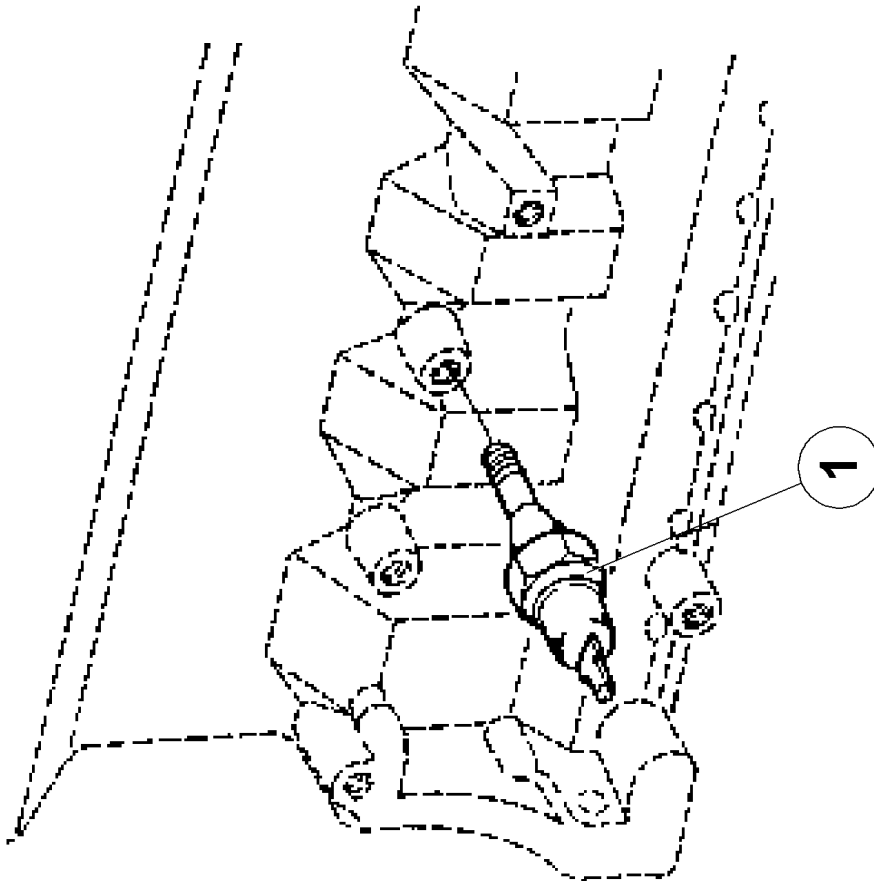

100 CRANKCASE 1)

Pos.	Part No.	Description	Dimension	Quantity	Conditions
1	60 0501 342 7	TRANSMITTER		1	
1)	Homologationtype				+ 4042

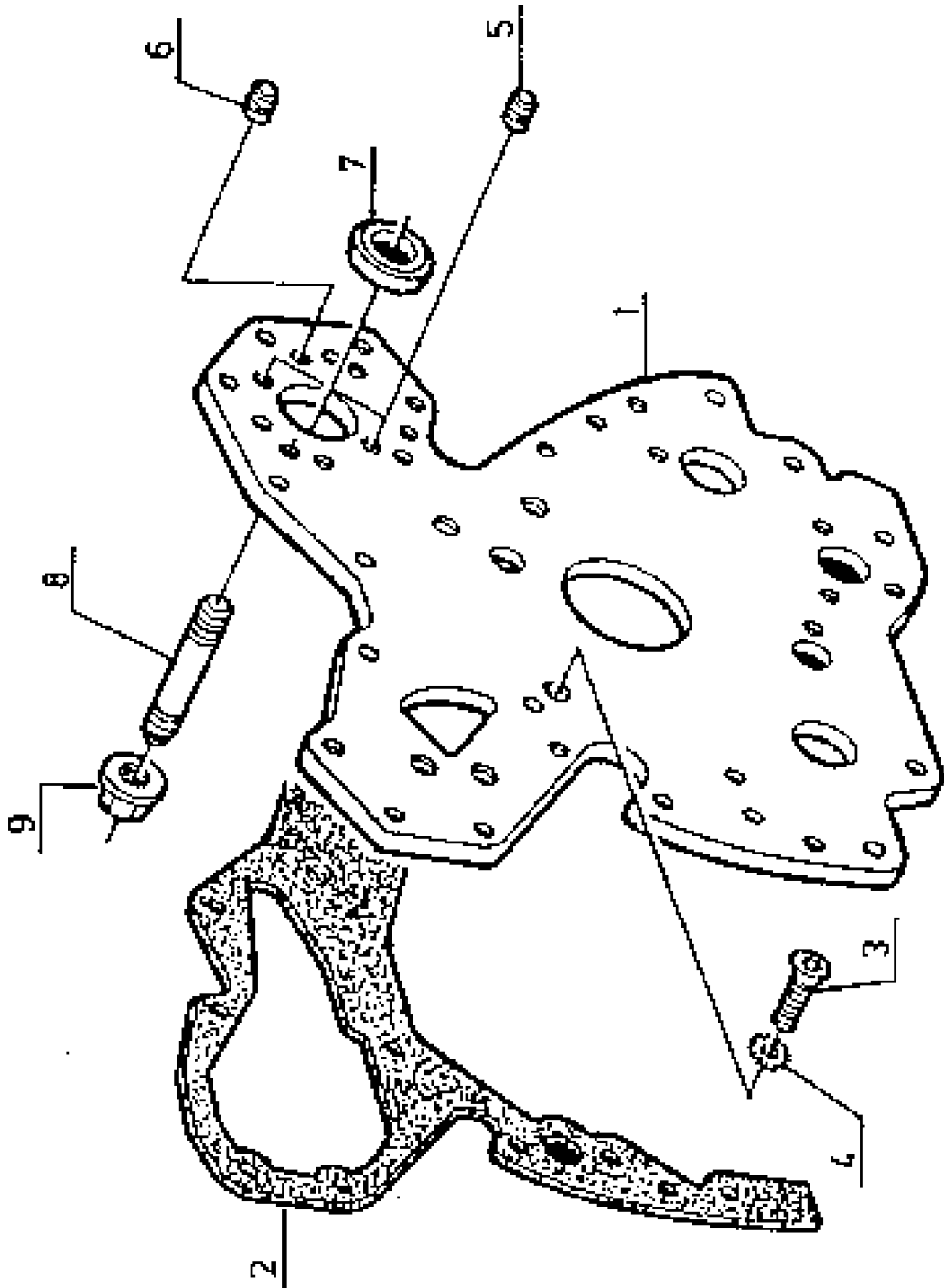

120 TIMING CASE

Pos.	Part No.	Description	Dimension	Quantity	Conditions
1	60 0501 597 3	PLATE		1	
2	60 0501 276 4	GASKET		1	
3	60 0501 276 5	SCREW		5	
4	60 0501 276 6	WASHER		5	
5	60 0501 597 4	LOCK		2	
6	60 0501 597 5	LOCK		8	
7	60 0501 597 6	RING		1	1)
8	60 0501 276 7	STUD		3	
9	60 0501 276 8	NUT		3	
1)	Remarks		[SR]		

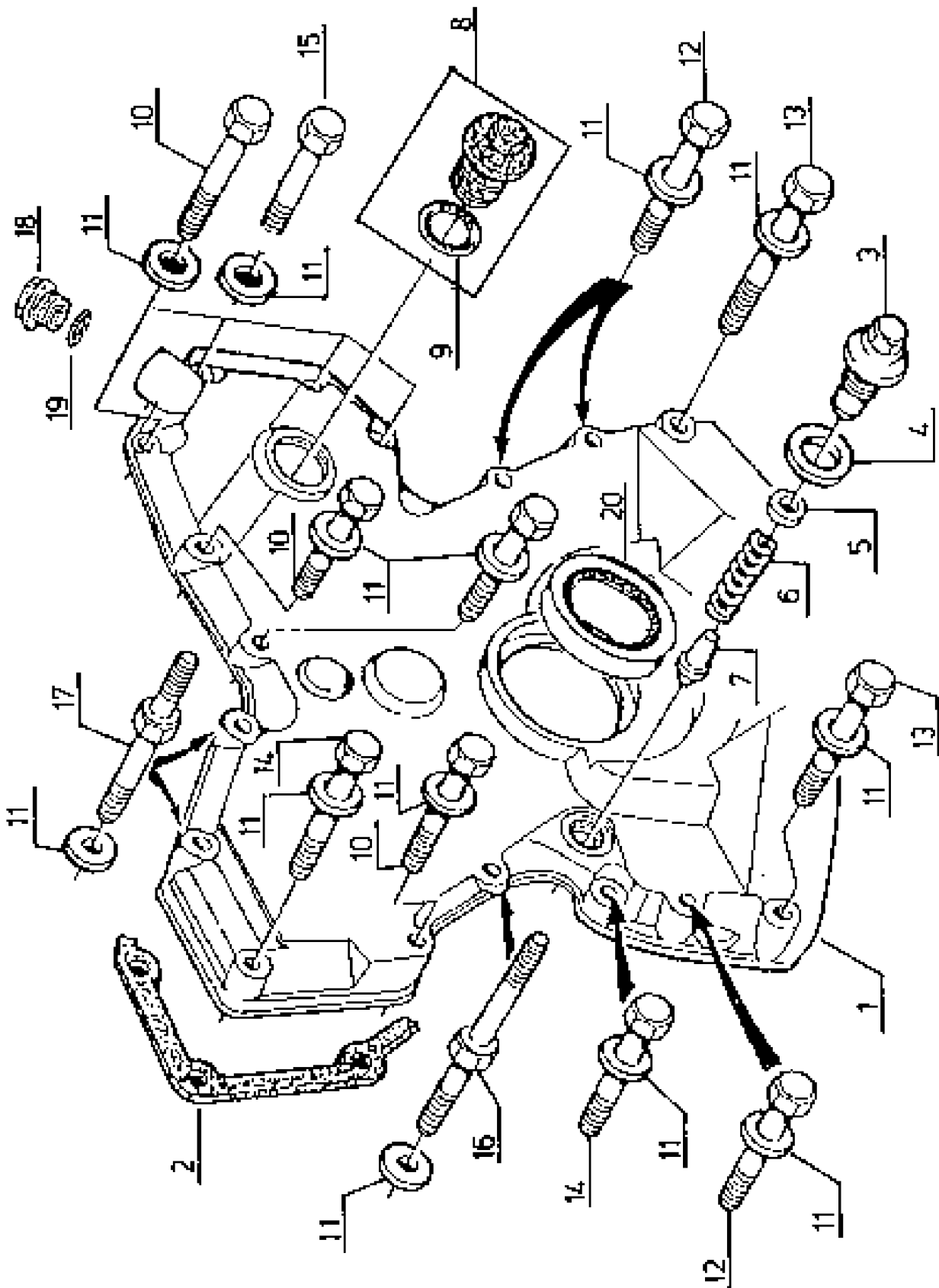

120 TIMING CASE

Pos.	Part No.	Description	Dimension	Quantity	Conditions
1	60 0501 597 7	HOUSING		1	
2	60 0501 597 8	GASKET		1	
3	60 0501 277 1	SCREW		1	
4	60 0501 277 2	WASHER		1	
5	60 0501 277 3	ADJUSTING DISC		1	1)
6	60 0501 277 4	SPRING		1	
7	60 0501 277 5	VALVE		1	
8	60 0501 277 6	LOCK		1	
9	60 0501 277 7	O-RING		1	
10	60 0501 277 8	SCREW		5	
11	60 0501 336 9	WASHER		17	
12	60 0501 278 0	SCREW		3	
13	60 0501 277 9	SCREW		2	
14	60 0501 278 1	SCREW		2	
15	60 0501 319 5	SCREW		1	
16	60 0502 233 3	STUD BOLT		1	
17	60 0502 233 4	STUD BOLT		2	
18	60 0502 895 5	SCREW PLUG	F-M20X1,5	1	
19	77 0002 464 6	O-RING	17X2-N ERS.D. 0238209.0	1	
20	60 0501 278 3	SHAFT SEAL		1	

1) Remarks

[SR]

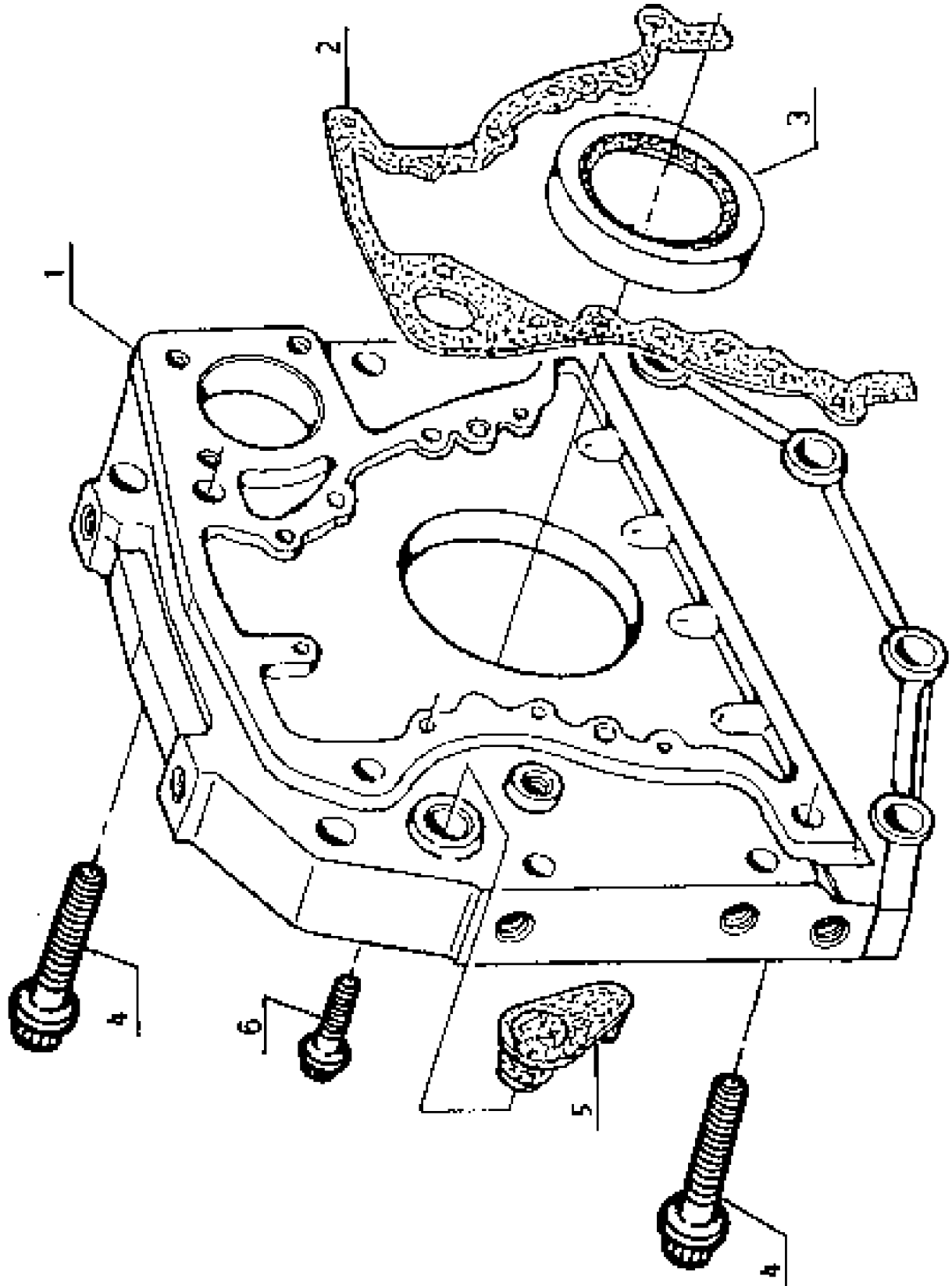

140 FLYWHEEL HOUSING 1)

Pos.	Part No.	Description	Dimension	Quantity	Conditions
1	FA-CONSIGN ES	Consignes - CS		1	
-		<i>Please order!</i>			
	60 0501 604 9	O-RING		1,000	
	60 0502 146 4	LOCK		1,000	
	77 0005 577 0	HOUSING		1,000	
	77 0005 577 1	GASKET		1,000	
2	60 0501 278 5	GASKET		1	
3	60 0501 279 0	SHAFT SEAL	118X146X15	1	
4	60 0501 611 6	BLANKING COVER		1	
5	60 0501 480 7	SCREW		4	
6	60 0501 480 8	SCREW		8	
1)	machine no.	4032			up to CT32R0335
	machine no.	4042			up to CT42R0597

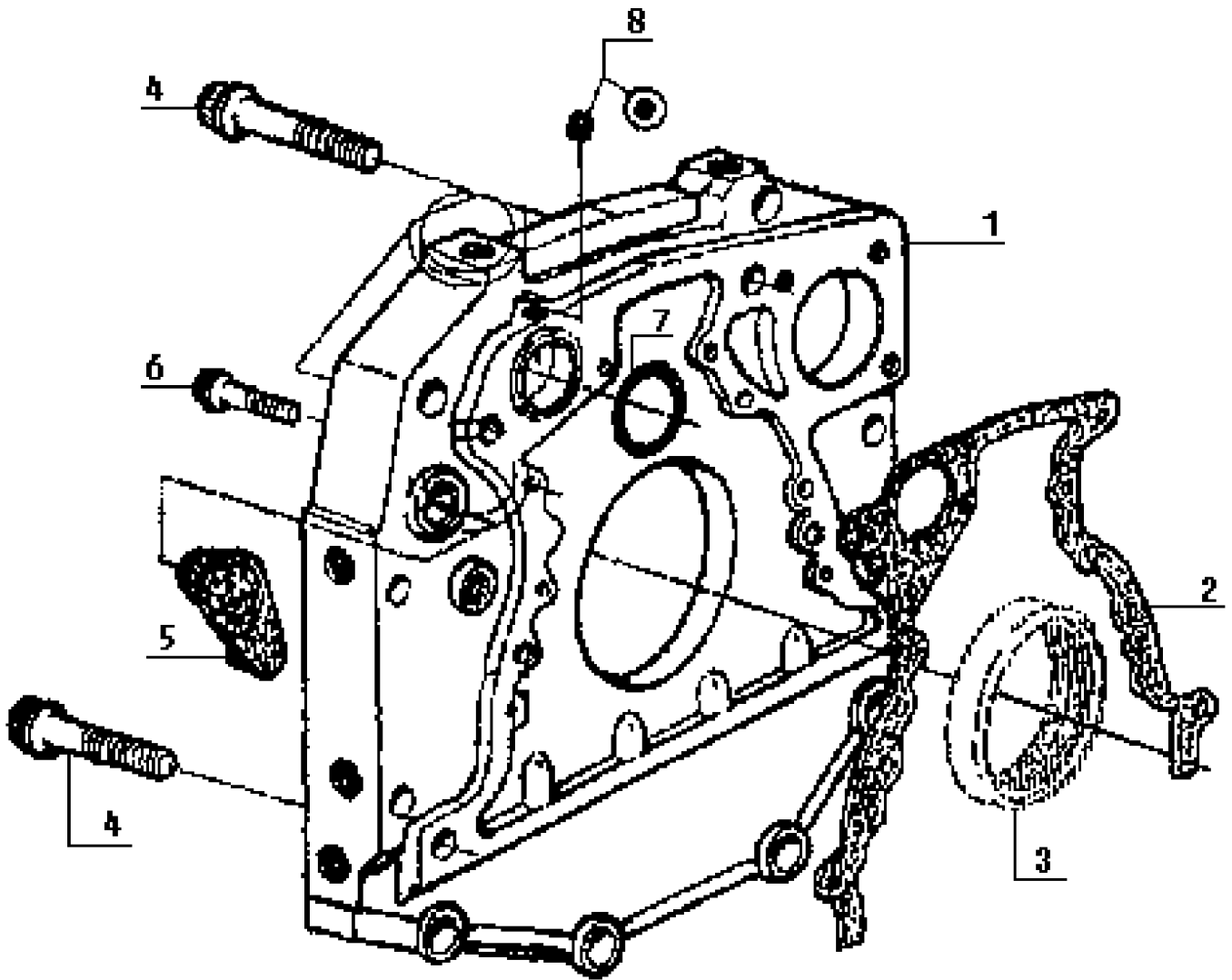

140 FLYWHEEL HOUSING 1)

Pos.	Part No.	Description	Dimension	Quantity	Conditions
1	FA-CONSIGN ES	Consignes - CS		1	
-		<i>Please order!</i>			
	60 0501 604 9	O-RING		1,000	
	77 0005 577 0	HOUSING		1,000	
	77 0005 577 1	GASKET		1,000	
2	FA-CONSIGN ES	Consignes - CS		1	
-		<i>Please order!</i>			
	77 0005 577 1	GASKET		1,000	
3	60 0501 279 0	SHAFT SEAL	118X146X15	1	
4	60 0501 480 7	SCREW		4	
5	60 0501 611 6	BLANKING COVER		1	
6	60 0501 480 8	SCREW		8	
7	77 0005 079 6	O-RING		1	
8	60 0502 146 4	LOCK		1	
1)	machine no.	4032			from CT32R0336 up to CT32R0518
	machine no.	4042			from CT42R0598 up to CT42R1136

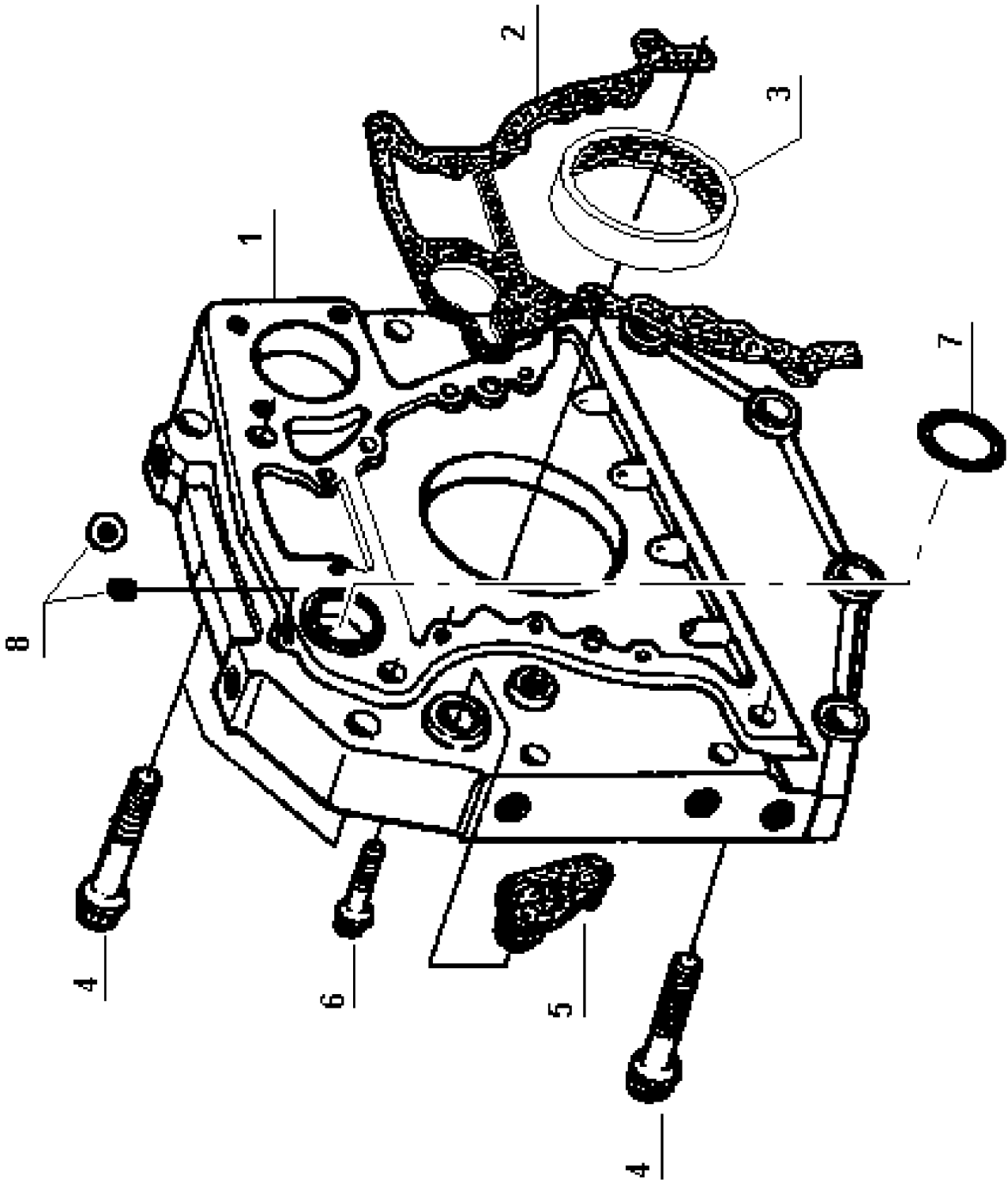

140 FLYWHEEL HOUSING 1)

Pos.	Part No.	Description	Dimension	Quantity	Conditions
1	77 0005 577 0	HOUSING		1	
2	77 0005 577 1	GASKET		1	
3	60 0501 279 0	SHAFT SEAL	118X146X15	1	
4	60 0501 480 7	SCREW		4	
5	60 0501 611 6	BLANKING COVER		1	
6	60 0501 480 8	SCREW		8	
7	60 0501 604 9	O-RING		1	
8	60 0502 146 4	LOCK		1	
1)	machine no.	4032			from CT32R0519
	machine no.	4042			from CT42R1137

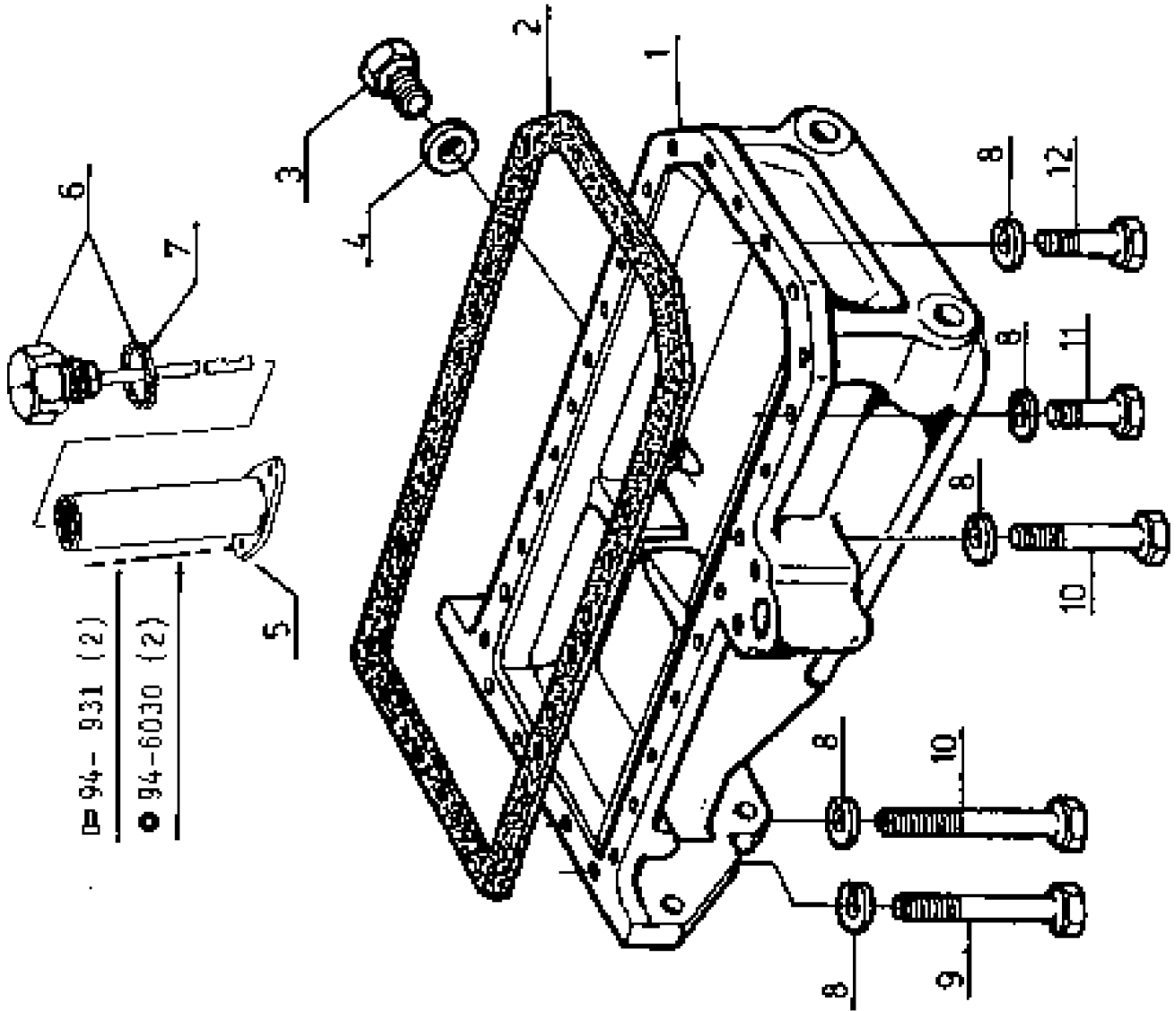

160 OIL PAN

Pos.	Part No.	Description	Dimension	Quantity	Conditions
1	60 0502 233 6	OIL SUMP		1	
2	60 0501 280 2	GASKET		1	
3	60 0501 279 3	LOCK		1	
4	60 0501 211 0	GASKET		1	
5	60 0501 279 4	TUBE		1	1)
5	60 0502 783 6	TUBE		1	2)
5	60 0501 279 4	TUBE		1	3)
6	60 0501 360 9	GAUGE		1	
7	60 0501 279 6	SEALING RING		1	
8	60 0501 280 0	WASHER		28	
9	60 0501 598 7	SCREW		2	
10	60 0501 598 8	SCREW		4	
11	60 0501 297 8	SCREW		16	
12	60 0502 604 3	SCREW		6	
1)	Homologationtype Motor	4045TRT01		- 4032 up to CD4045T374184	
2)	Homologationtype Motor	4045TRT01		- 4032 from CD4045T374185	
3)	Homologationtype			+ 4032	

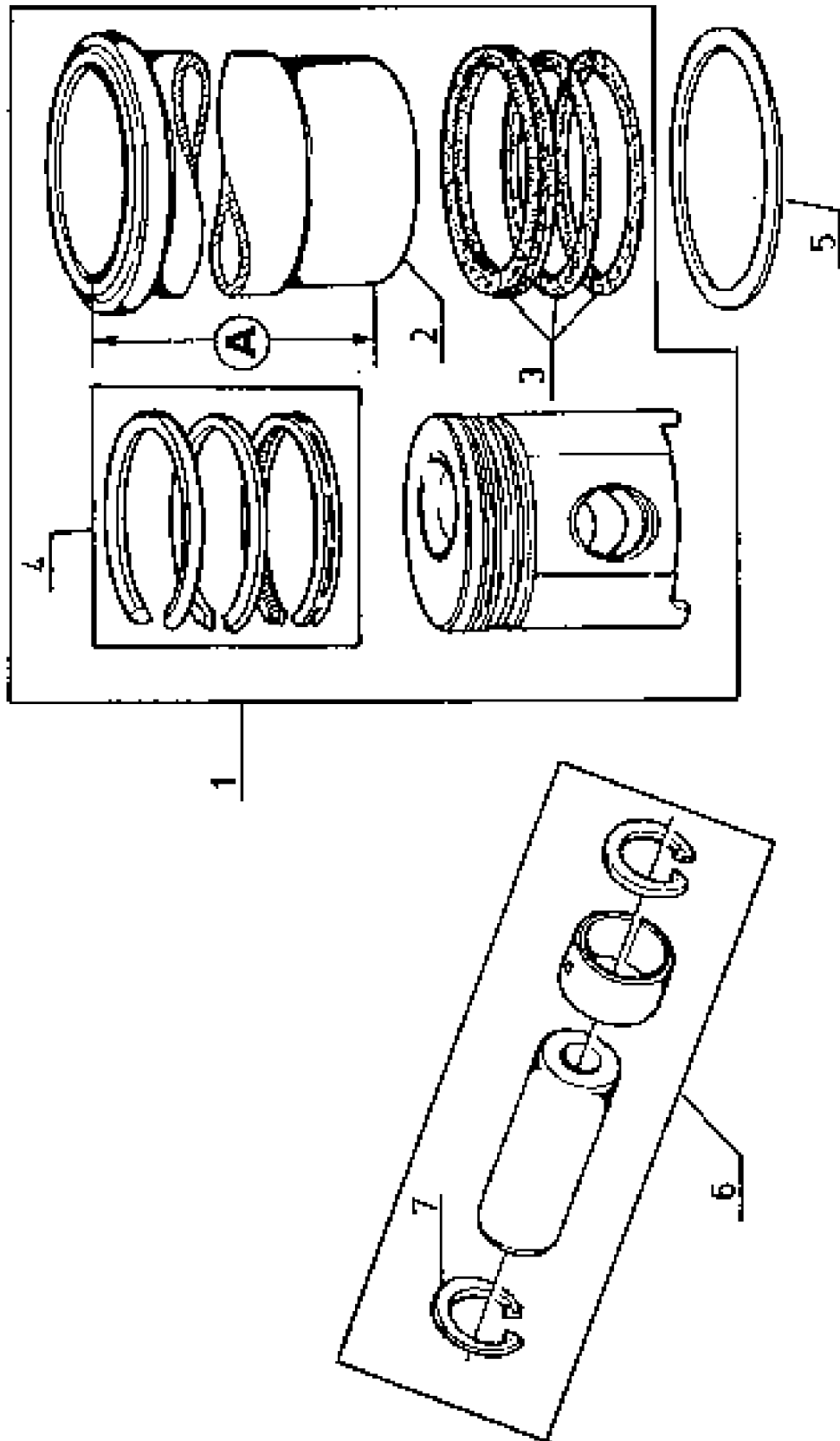

100 CYLINDER LINER, PISTON

Pos.	Part No.	Description	Dimension	Quantity	Conditions
1	60 0501 280 6	PISTON-LINER		4	1)
1	60 0501 407 0	PISTON-LINER		4	2)
1	00 1171 024 0	PISTON-LINER		1	3)
2	60 0501 280 7	PISTON-LINER		4	1)
2	FA-CONSIGN ES	Consignes - CS		4	2)
-		<i>Please order!</i> <i>60 0501 407 0 PISTON-LINER</i>		1,000	
3	60 0501 280 9	SEALING RING SET		4	
4	60 0501 281 0	SET OF PISTON RINGS		4	
5	60 0501 281 5	ADJUSTING DISC		4	4)
5	60 0501 281 6	ADJUSTING DISC		4	5)
6	60 0501 591 0	AXLE		4	6)
7	60 0501 281 4	INNER CIRCLIP		8	
1)	Homologationtype		+ 4032		
2)	Homologationtype		+ 4042		
3)	Homologationtype		+ 4042 Only 1 cubic capacity (1 cyl)		
4)	Remarks		ép.0,05mm		
5)	Remarks		ép.0,10mm		
6)	Remarks		DE.41mm		

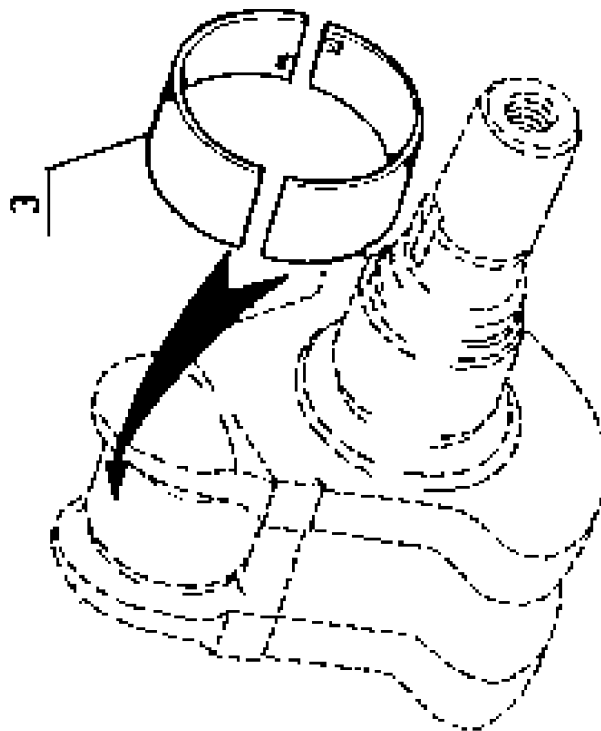
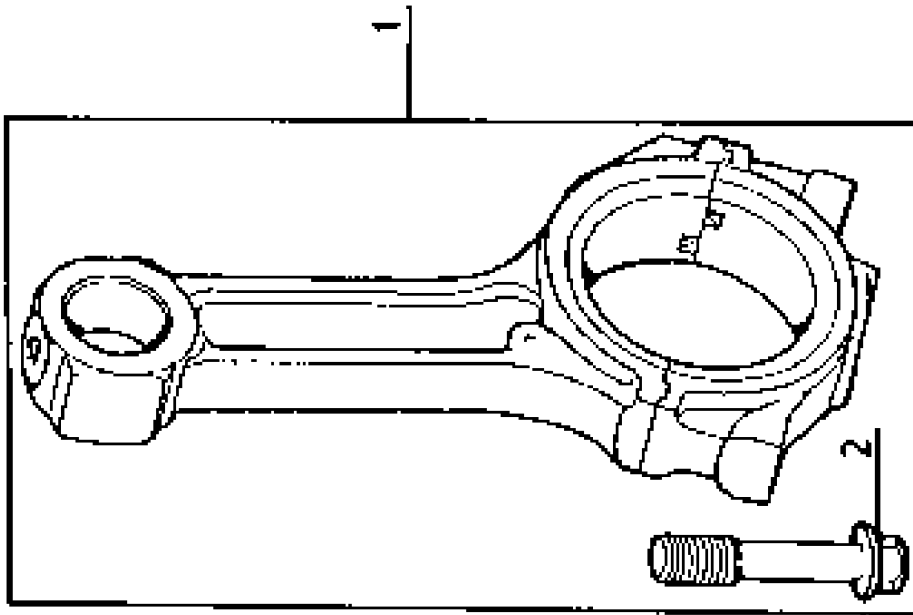

120 CONNECTING ROD, CONNECTING ROD BEARINGS

Pos.	Part No.	Description	Dimension	Quantity	Conditions
1	60 0501 281 9	CONNECTING ROD		4	1)
1	60 0501 281 8	ROD (ENGINE)		4	2)
2	60 0501 282 2	SCREW		8	1)
2	60 0501 282 9	SCREW		8	2)
3	60 0501 282 7	BEARING		4	1)
3	60 0501 282 5	BEARING		4	2)
3	60 0501 282 8	BEARING		4	3)
3	60 0501 282 6	BEARING		4	3)
<hr/>					
1)	Homologationtype		+ 4032		
<hr/>					
2)	Homologationtype		+ 4042		
<hr/>					
3)	Homologationtype		+ 4032		
			-0,254mm		
<hr/>					

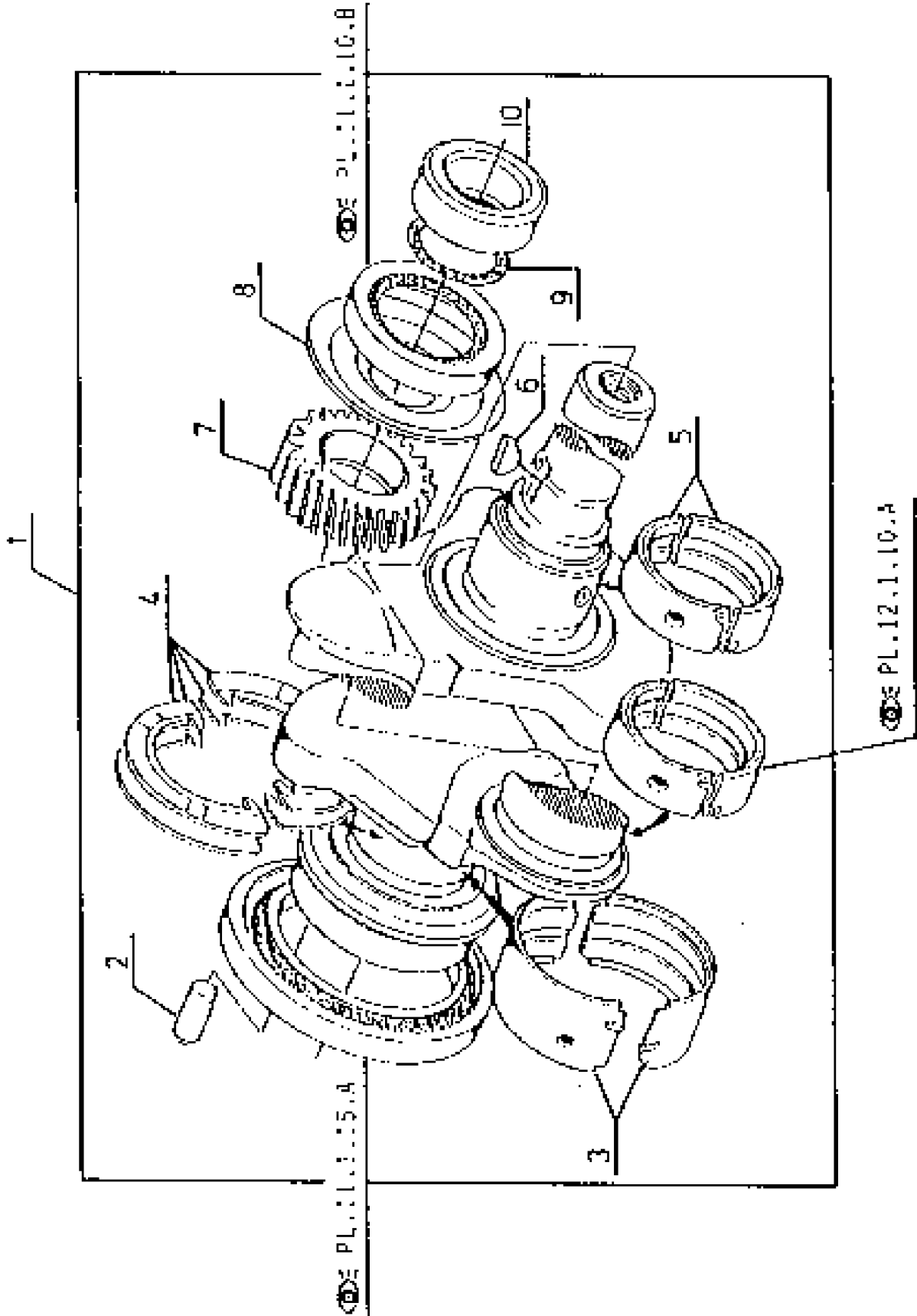

140 CRANKSHAFT

Pos.	Part No.	Description	Dimension	Quantity	Conditions
1	60 0501 404 1	CRANKSHAFT		1	1)
1	60 0501 317 3	CRANKSHAFT		1	2)
2	60 0501 317 4	CENTRING PIN		1	
3	60 0501 317 5	BEARING		1	
3	60 0501 317 6	BEARING		1	3)
4	60 0501 317 7	FLANGE		1	
4	60 0501 317 8	FLANGE		1	4)
5	60 0501 591 2	BEARING		4	
5	60 0501 591 3	BEARING		4	3)
6	60 0501 294 0	KEY		1	
7	60 0501 599 2	WHEEL		1	5)
8	60 0501 318 1	DEFLECTOR		1	
9	60 0501 318 3	O-RING		1	
10	60 0501 318 4	SLEEVE		1	
1)	Homologationtype		+ 4032		
2)	Homologationtype		+ 4042		
3)	Remarks		-0,254mm		
4)	Remarks		ép.+0,18		
5)	Remarks		24dts.		

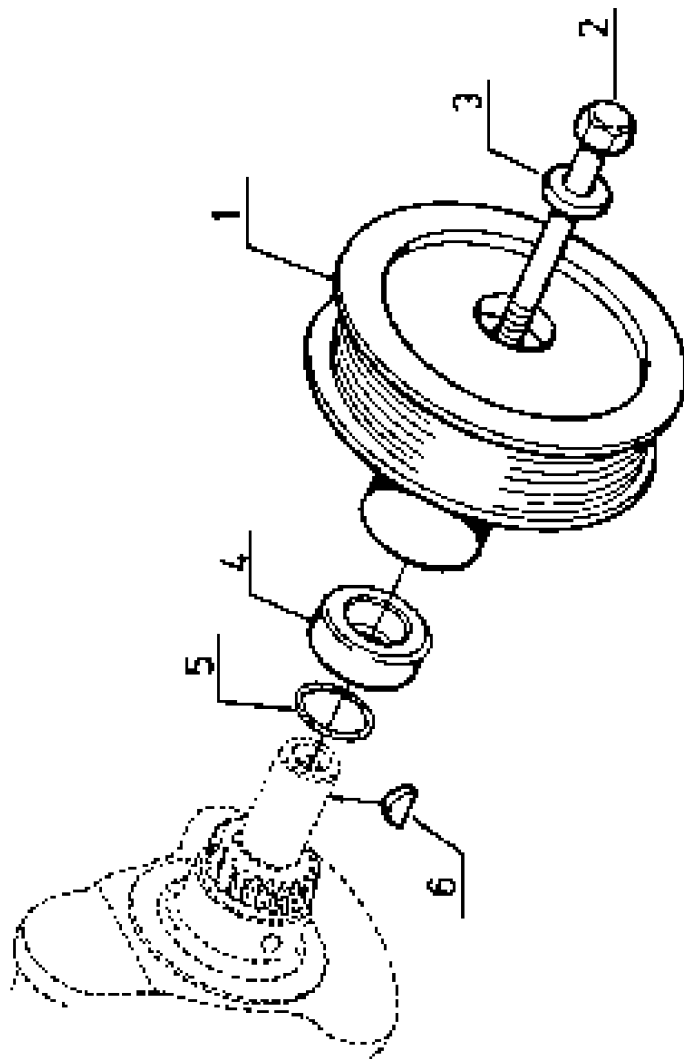

161 CRANKSHAFT PULLEY WHEEL 1)

Pos.	Part No.	Description	Dimension	Quantity	Conditions
1	77 0004 454 2	CRANKSHAFT PULLEY		1	
2	60 0501 340 6	SCREW		1	
3	77 0004 256 4	SPACER		1	
4	60 0501 318 4	SLEEVE		1	
5	60 0501 318 3	O-RING		1	
6	60 0501 340 5	KEY		1	
<hr/>					
1)	Equipment				
		OK0060			W/OUT FR LIFTING AND PTO



Suggest:

For more complete manuals. Please go to the home page.

<https://www.ebooklibonline.com>

If the above button click is invalid. Please download this document first, and then click the above link to download the complete manual.

Thank you so much for reading

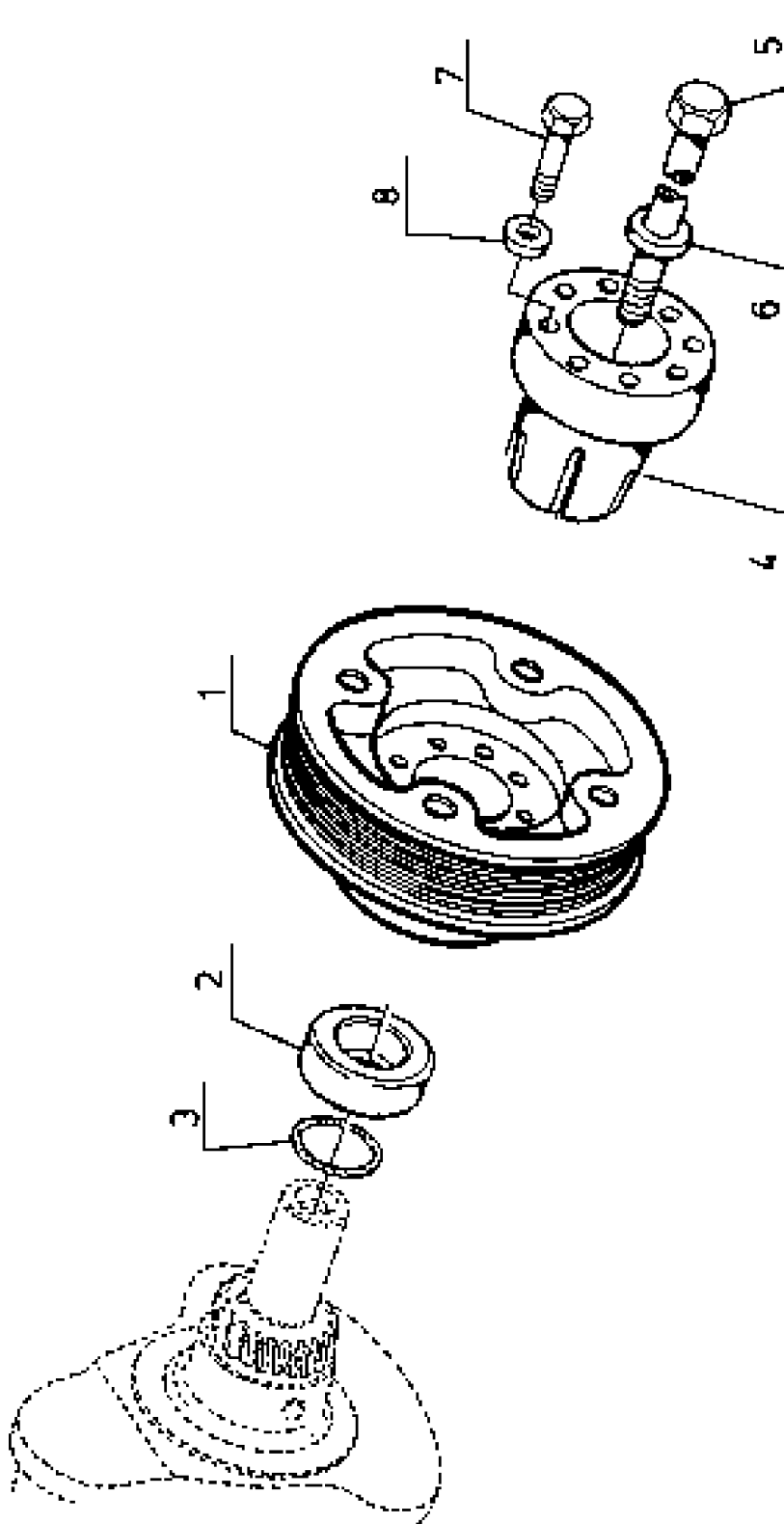

161 CRANKSHAFT PULLEY WHEEL 1)

Pos.	Part No.	Description	Dimension	Quantity	Conditions
1	77 0004 454 1	CRANKSHAFT PULLEY		1	
2	60 0501 318 4	SLEEVE		1	
3	60 0501 318 3	O-RING		1	
4	77 0004 256 3	HUB		1	
5	77 0004 256 5	SCREW		1	
6	77 0004 256 4	SPACER		1	
7	60 0501 278 7	SCREW		8	
8	60 0501 341 2	WASHER		8	

1) Equipment

	OK0061	FR PTO
machine no.	OK0063	FR LIFT AND PTO
machine no.	4032	up to CT32R0592
	4042	up to CT42R1435

<https://www.ebooklibonline.com>

Hello dear friend!

Thank you very much for reading.

Enter the link into your browser.

The full manual is available for immediate download.

<https://www.ebooklibonline.com>