

Section: ENGINE
CRANKCASE

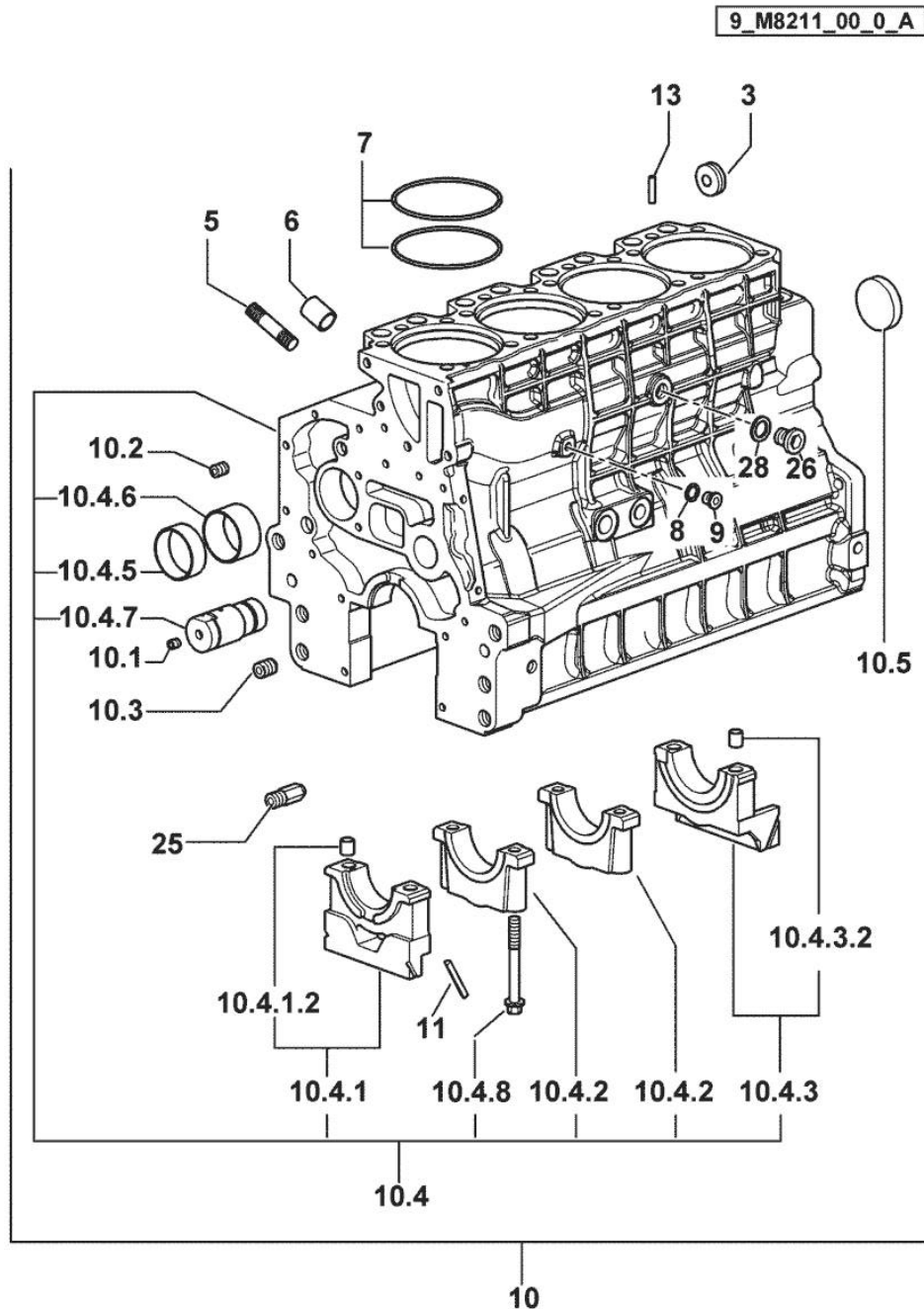

Fig.	P/n	QTY	Name
------	-----	-----	------

Notes:
 [XS-90(20")]

3	2.3199.312.2/10	1	plug
5	2.0439.273.7	8	stud bolt m 8
6	2.1559.188.2	4	bush 11.4 x 14 x16
7	2.1539.193.0	8	special oil seal 107.62x2.62
8	2.1560.010.0	1	gasket 14.2 x 20
9	2.3199.292.0	1	plug 1/4" gas
10	0.013.0489.4/30	1	crankcase
10.1	2.3130.001.1	10	plug 1/8" gas
10.2	2.3130.002.1	2	plug 1/4" gas
10.3	2.3130.003.1	6	plug 3/8" gas
10.4	0.000.0000.1		cannot be supplied
10.4.1	0.065.1112.7	1	support
10.4.1.2	2.1699.165.0	1	bush 12.3x15x16
10.4.2	0.065.1114.0/10	3	support
10.4.3	0.065.1116.3	1	support
10.4.3.2	2.1699.165.0	1	bush 12.3x15x16
10.4.5	0.065.1140.0	4	special bushing 59X55X20
10.4.6	0.065.1141.0	1	special bushing 59X55X30
10.4.7	0.066.1151.0	1	pin
10.4.8	0.065.1117.0	10	screw m 12 x 100
10.5	2.3179.012.0	1	plug 60
11	0.066.1152.0/10	4	gasket
13	2.1549.154.2	4	bush 4.8x5.8x16
25	0.013.4946.0/10	1	sprayer nozzle
26	2.3120.101.0	1	plug m 18 p.1.5
28	2.1560.014.0	1	washer 18.2 x 24

Section: ENGINE

TIMING CASE

Fig.	P/n	QTY	Name
------	-----	-----	------

Notes:
[XS-90(20")]

4	2.0432.009.7	1	stud bolt m 8 p.1.25 / p. 1 x 35
15	2.0432.003.7	1	stud bolt m 8 p.1.25 / p.1 x 20
16	2.0312.214.2	7	screw m 8 p.1.25 x 40
17	2.1480.014.1	15	washer 8
18	0.013.4981.0	1	guard
19	0.065.1150.0/30	1	gasket
20	2.1470.004.2	4	lock washer 8
21	2.1011.405.2	2	nut m 8 p.1
22	2.0312.208.2	8	screw m 8 p.1.25 x 25
23	2.1529.167.0	1	oil seal

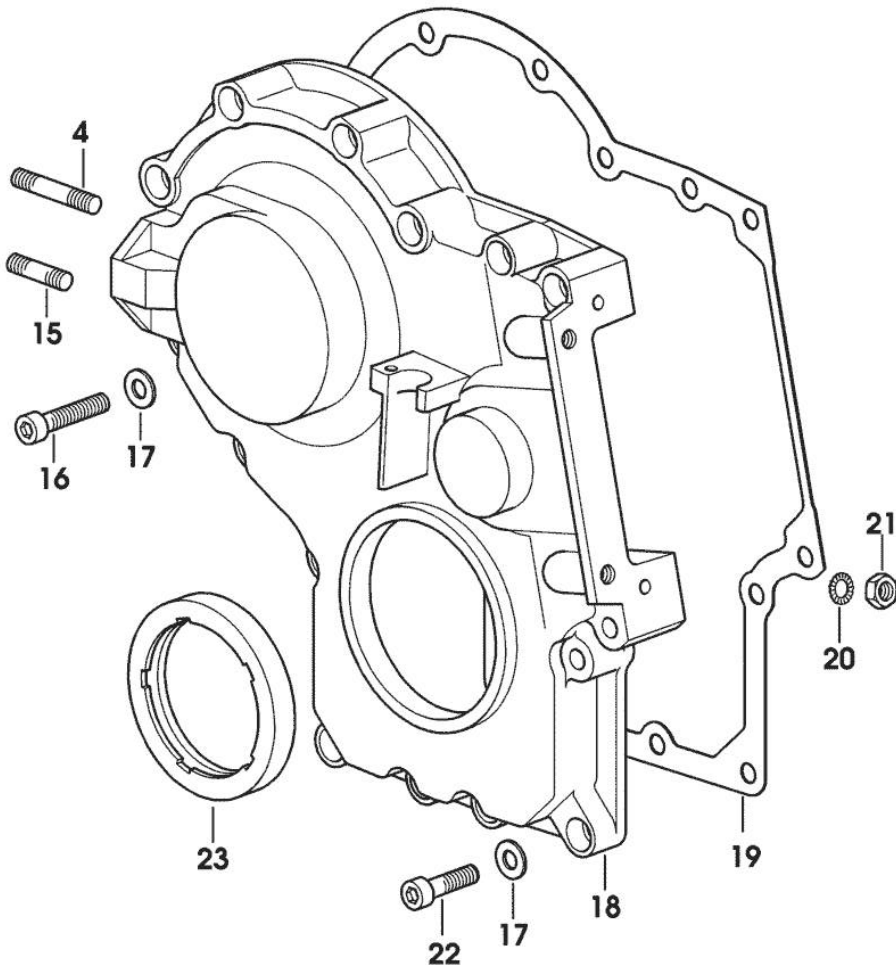

9_M8211_00_0_B

Section: ENGINE
CASING COVER

Fig.	P/n	QTY	Name
------	-----	-----	------

Notes:
 [XS-90(20")]

30	0.065.1152.0	1	gasket
31	0.013.6374.2	1	cover
32	0.013.6368.0/10	4	stud bolt m 8 p.1 / = mm 46.5
34	2.1310.004.2	8	flat washer 8.4x17
35	2.1011.405.2	4	nut m 8 p.1

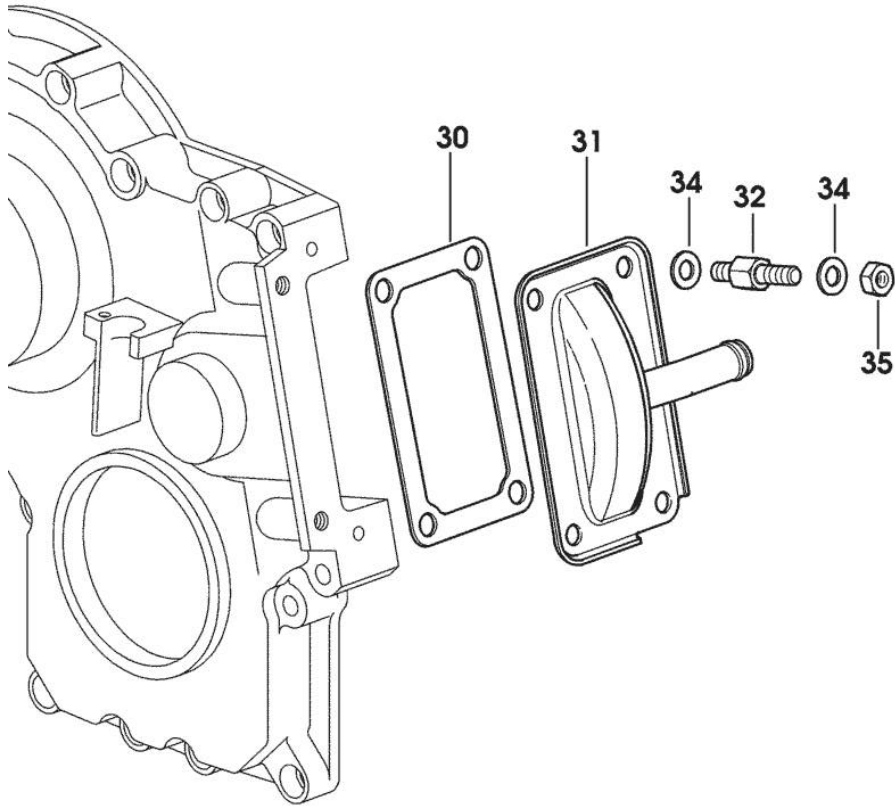

9_N1411_01_0_0

<https://www.ebooklibonline.com>

Hello dear friend!

Thank you very much for reading.

Enter the link into your browser.

The full manual is available for immediate download.

<https://www.ebooklibonline.com>

Section: ENGINE
GUARD PLATE

Fig.	P/n	QTY	Name
------	-----	-----	------

Notes:
 [XS-90(20")]

1	0.007.1262.3/50	1	guard
2	0.007.1271.0/10	1	small column m 8 p.1.25 / L = mm 60
3	0.007.1272.0/10	2	small column m 8 p.1.25 / L = mm 50
5	2.1310.004.2	3	flat washer 8.4x17
7	2.0112.203.2	3	screw m 8 p.1.25 x 12

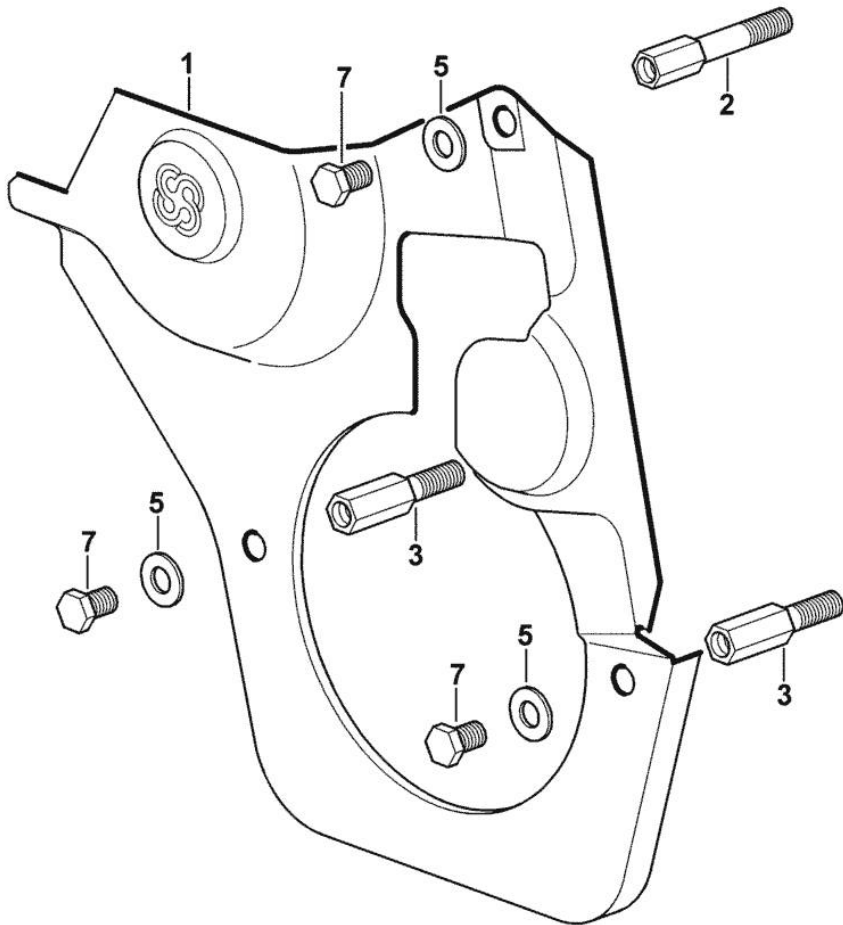

MONOBLOC ENGINE-GEARBOX CONNECTING FLANGE

Fig.	P/n	QTY	Name
------	-----	-----	------

Notes:
[XS-90(20")]

1	0.007.1882.0/50	1	flange
2	2.0112.511.2	8	screw m 14 p.2 x 30
3	2.1651.912.0	2	cylindrical plug 12x28
4	2.1651.917.0	1	cylindrical plug 12x40
5	2.0432.257.7	1	stud bolt m 12 p.1.75 - 1.25 x 30
6	2.0439.250.7	1	stud bolt m 12 / m 10 x 30
7	0.011.9294.0/10	1	bush

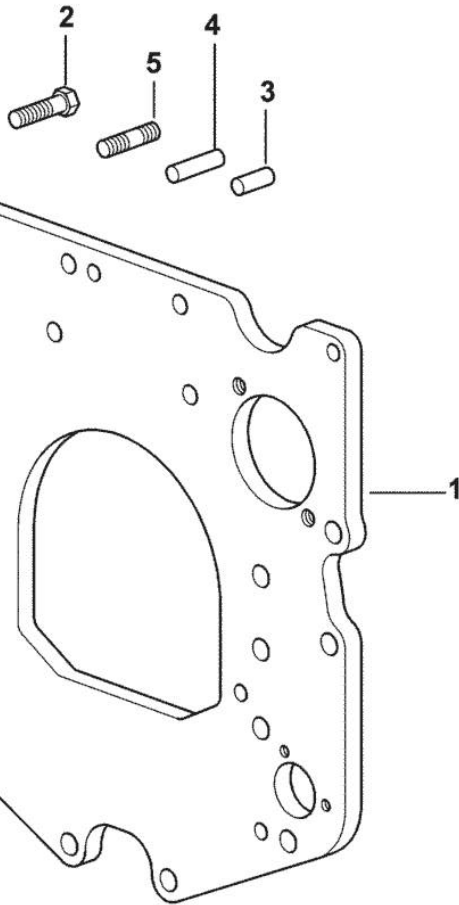

9_38611_01_0_0

PLUG

Fig.	P/n	QTY	Name
------	-----	-----	------

Notes:
[XS-90(20")]

1	2.3130.003.1	1	plug 3/8" gas
---	--------------	---	---------------

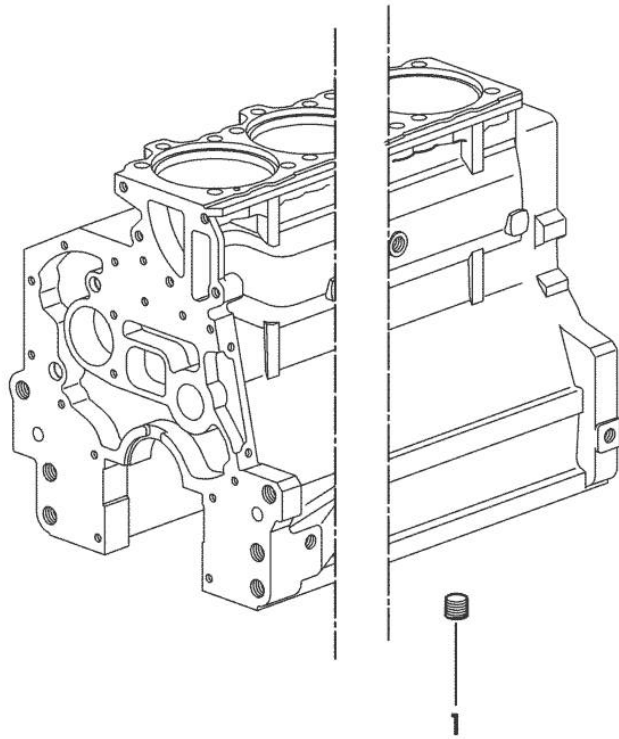

9_34311_06_0_0

Section: ENGINE

CRANKSHAFT

9_33212_00_0_0

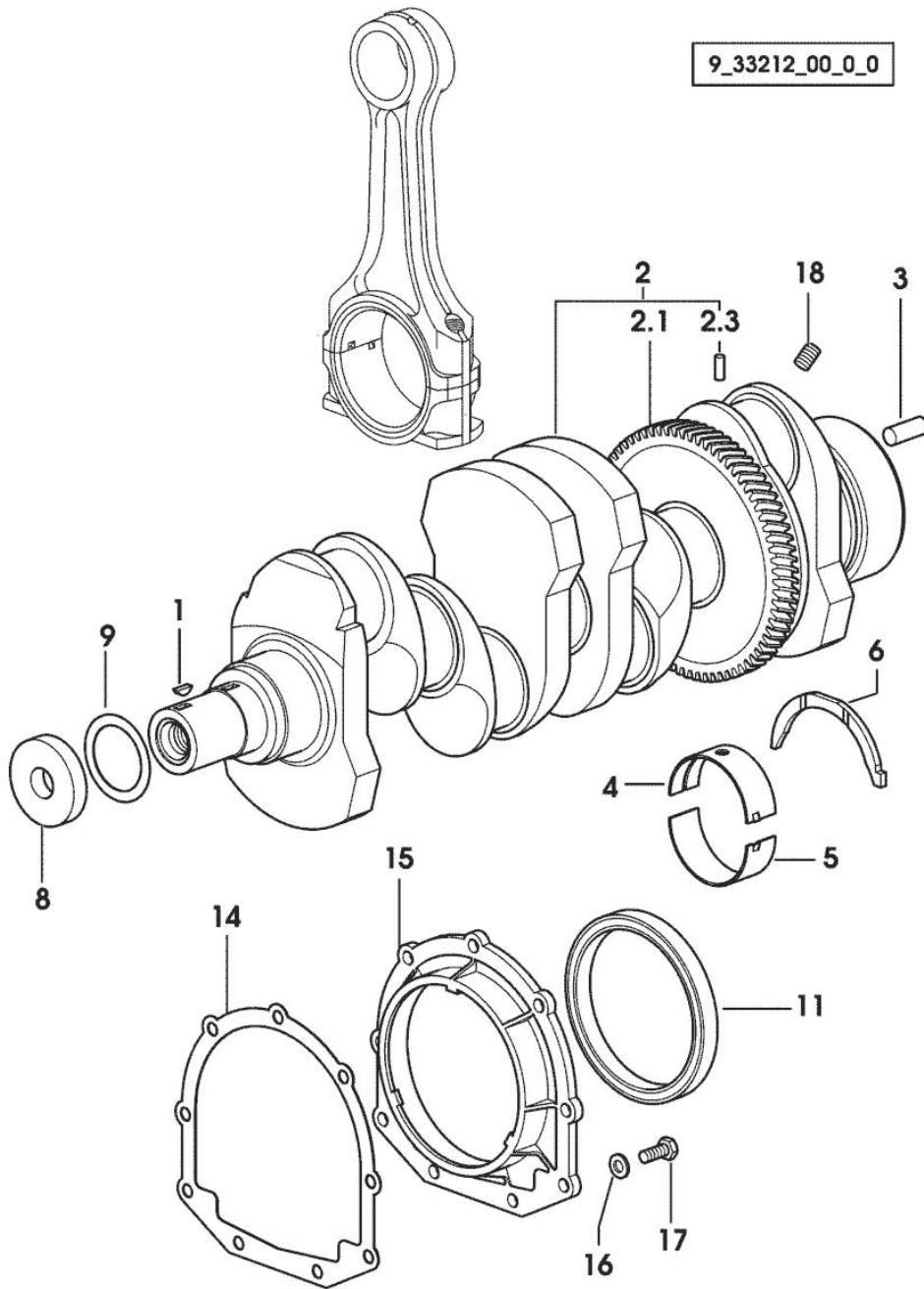

Fig.	P/n	QTY	Name
------	-----	-----	------

Notes:
[XS-90(20")]

1	2.1720.006.0	1	key 4x6.5
2	0.086.1210.3/30	1	crankshaft
2.1	0.065.1211.0/10	1	crown wheel
2.3	2.1630.608.0	1	pin 6x16
3	2.1651.915.0	1	pin 12x35
4	0.065.1215.0	5	main half bushing STANDARD
4	0.065.1215.7		main half bushing - mm 0.25
4	0.065.1215.8		main half bushing - mm 0.50
5	0.065.1216.0	5	main half bushing
5	0.065.1216.7		main half bushing - mm 0.25
5	0.065.1216.8		main half bushing - mm 0.50
6	0.065.1218.0	4	shim STANDARD
6	0.065.1218.7		shim + mm 0.10
6	0.065.1218.8		shim + mm 0.15
8	2.1599.524.7	1	washer 21x60x12
9	2.1589.189.0	2	shoulder ring mm 1.00
11	2.1529.073.0	1	special oil seal 110x130x13
14	0.065.1254.0/20	1	gasket
15	0.007.1711.0/10	1	cover
16	2.1475.002.2	9	conical washer 8
17	2.0112.207.2	9	screw m 8 p 1.25 x 20
18	2.3130.001.1	4	plug 1/8" gas

Section: ENGINE

CYLINDER - PISTON - CONNECTING ROD

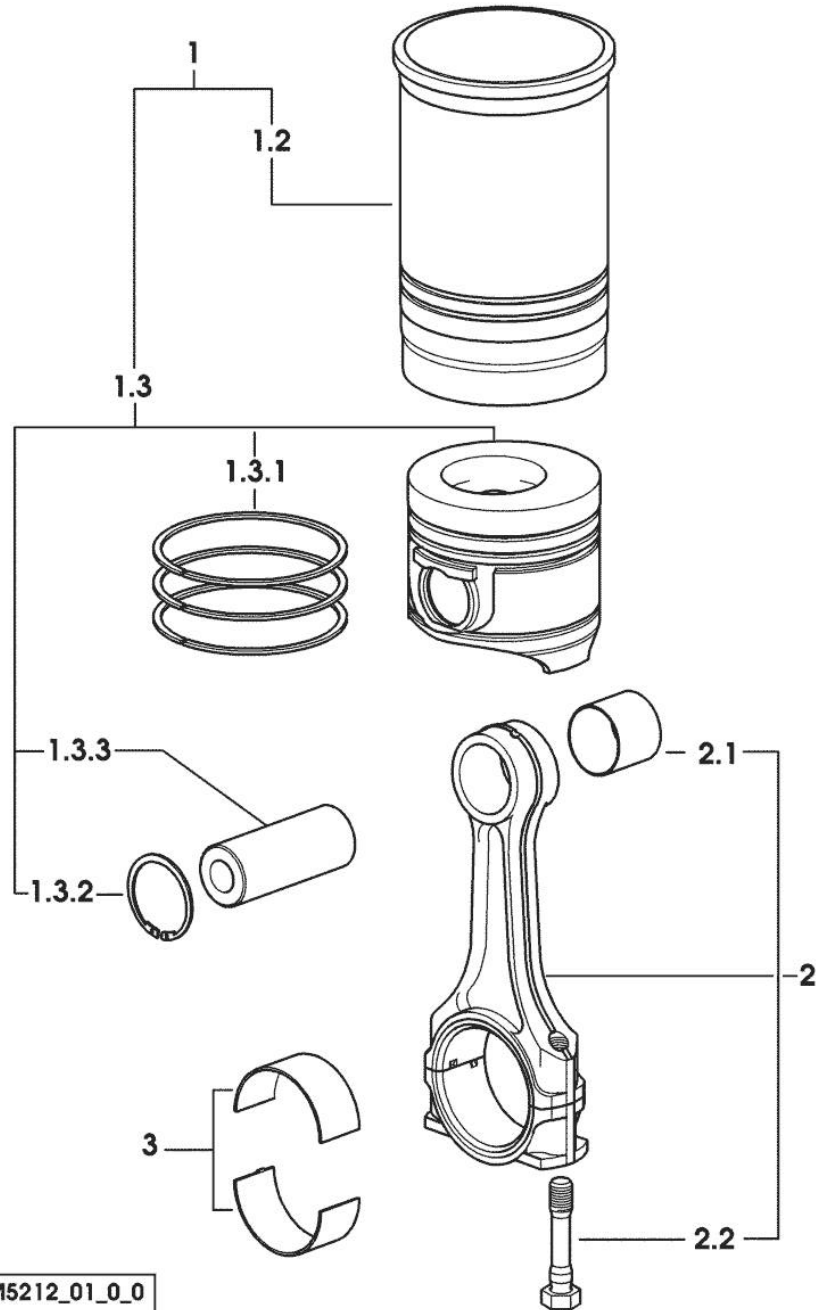

Fig.	P/n	QTY	Name
------	-----	-----	------

Notes:
[XS-90(20")]

1	0.099.0065.A	4	cyl. piston assembly "A" - CLASS A
1	0.099.0065.B	4	cyl. piston assembly "B" - CLASS B
1.2	0.A12.2675.0	1	engine cylinder "A" - CLASS A
1.2	0.B12.2675.0	1	engine cylinder "B" - CLASS B
1.3	0.099.0060.A	1	complete piston "A" - CLASS A
1.3	0.099.0060.B	1	complete piston "B" - CLASS B
1.3.1	0.081.0090.6/10	1	piston ring set
1.3.2	2.1411.014.1	2	circlip 35
1.3.3	0.078.1236.0	1	piston pin Ø 18 / Ø 35 / L = mm 86
2	0.078.1220.3/30	4	engine connecting rod
2.1	2.1559.114.0/10	1	special bushing
2.2	2.0399.213.0	2	screw m 12 p.1.25x61.5
3	0.065.1225.0	8	con.rod half bushing STANDARD - A = 28.75 -> 29.00
3	0.065.1225.7	8	con.rod half bushing - mm 0.25
3	0.065.1225.8	8	con.rod half bushing - mm 0.50

Section: ENGINE

CRANKSHAFT PULLEY

Fig.	P/n	QTY	Name
------	-----	-----	------

Notes:
[XS-90(20")]

1	0.013.6349.0/10	1	pulley
2	0.011.3515.0/20	1	hub Z = 48
3	0.065.1256.0	2	ring 45x52
4	2.1579.865.0	1	spacer 45.2x51.8x10
5	2.0439.195.7	1	stud bolt m 20 p.1.5x80
6	2.1019.094.7	1	nut m 20 p.1.5
7	2.0112.320.2	6	screw m 10 p.1.5 x 55
8	2.1470.006.2	6	lock washer 10

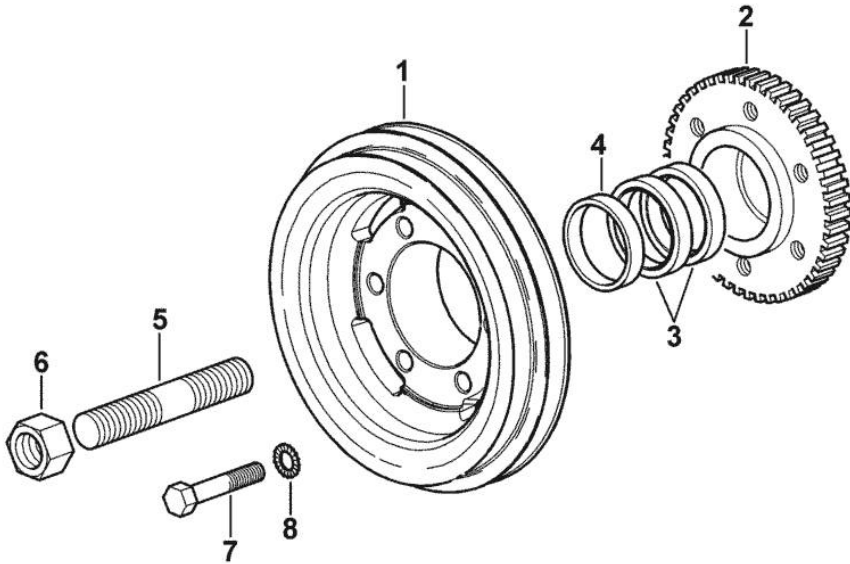

9_N1412_03_0_0

Section: ENGINE

ENGINE FLYWHEEL

Fig.	P/n	QTY	Name
------	-----	-----	------

Notes:
[XS-90(20")]

50	0.255.2525.0/10	1	flange
51	0.076.1247.3/20	1	flywheel
51.2	0.065.1242.0	1	crown wheel Z = 123
52	2.0139.022.2	6	screw m 12 p.1.25x55

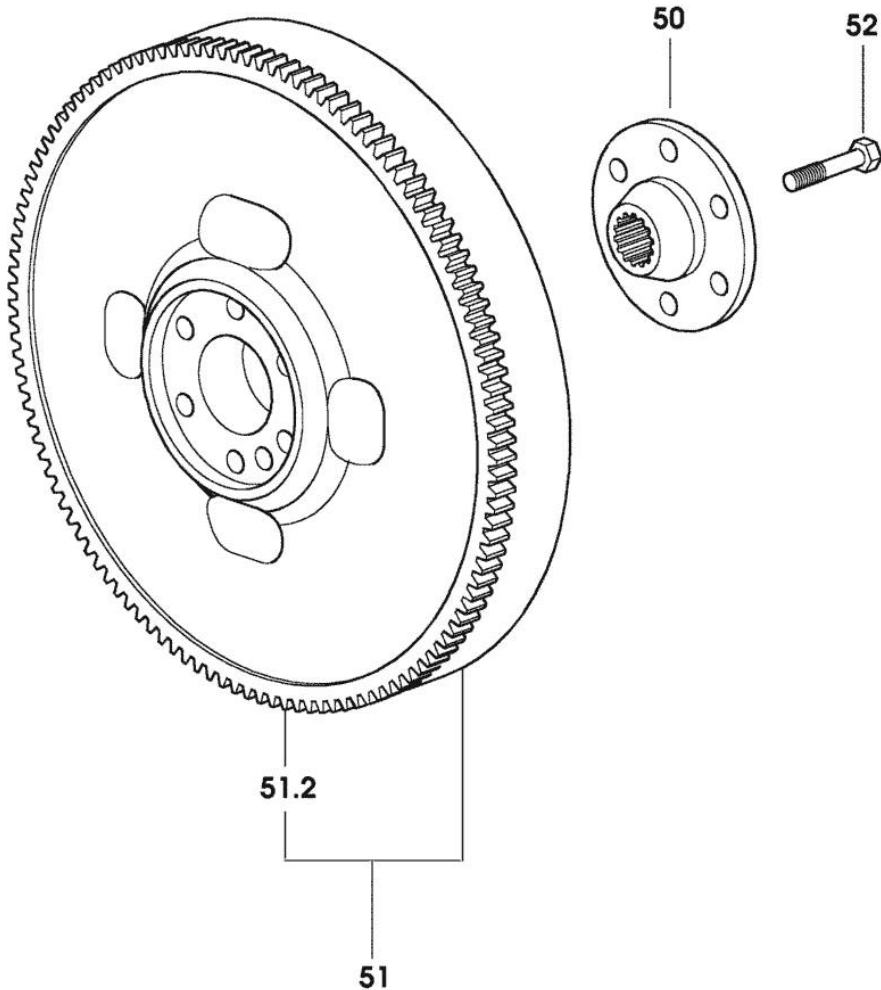

9_33212_07_0_0

Section: ENGINE
COUNTERWEIGHTS

Fig.	P/n	QTY	Name
------	-----	-----	------

Notes:
 [XS-90(20")]

25	2.1589.139.0	1	shoulder ring mm 0.3
26	2.1589.140.0	3	shoulder ring mm 0.1
29	2.1579.628.0	3	spacer 16.5x26x0.1
33	2.1579.629.0	6	spacer 12.5x26x0.1
34	2.1589.048.0	1	shoulder ring 16.5x26x0.3
35	2.1589.049.0	1	shoulder ring 12.5x26x0.3
40	0.086.1233.3/30	1	mass sx/lh/li
40.2	2.1559.115.0	2	special bushing 26x30x30
40.3	0.000.0000.1		cannot be supplied
40.4	2.1651.302.0	1	roll pin 4x6
41	0.065.1233.3/30	1	mass dx/rh/re
41.2	2.1559.115.0	2	special bushing 26x30x30
41.3	0.000.0000.1		cannot be supplied
41.99	0.000.0000.1		cannot be supplied
41.99.4	2.1651.302.0	1	roll pin 4x6
41.99.5	2.1410.018.7	1	circlip 45
42	0.000.0000.1		cannot be supplied
42.1	0.086.1231.0/10	1	box
42.2	2.3130.001.1	4	plug 1/8" gas
43	2.1631.717.0	2	roll pin 8 x 40
44	2.1579.626.0	2	spacer 13.2x16x11
45	2.0139.028.2	4	screw m 12
46	2.1699.191.0	1	bush 7x10x16
47	0.000.0000.1		cannot be supplied
47.1	0.065.1234.0/10	1	shaft
47.2	2.3130.001.1	1	plug 1/8" gas
48	2.1589.185.0	4	shoulder ring 26.1x34x1

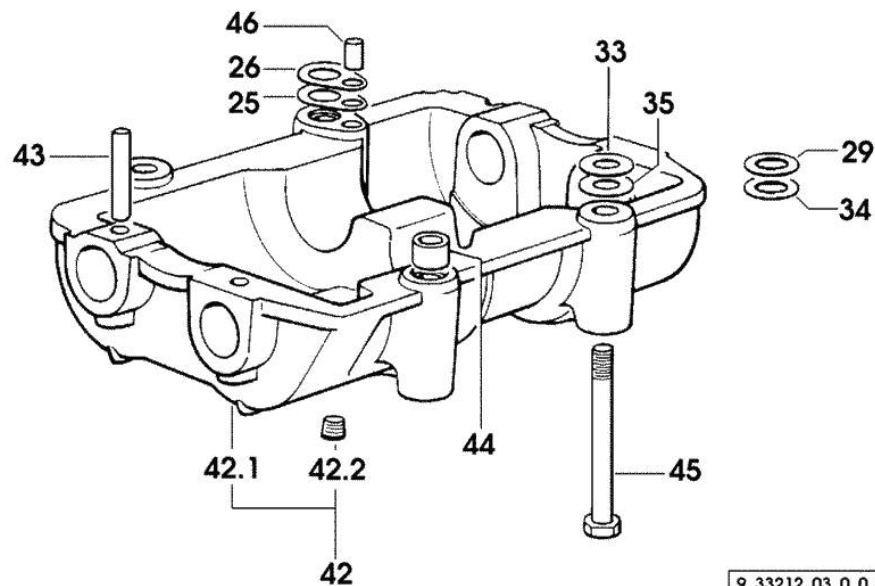
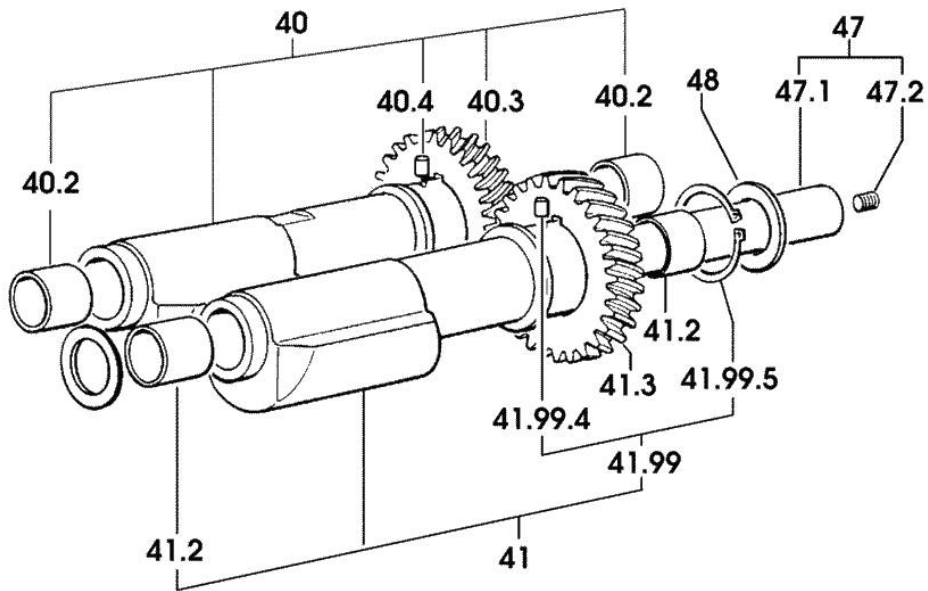

9_33212_03_0_0

Section: ENGINE

CAMSHAFT

Fig.	P/n	QTY	Name
------	-----	-----	------

Notes:
[XS-90(20")]

1	0.065.1331.2	8	rod
2	0.012.6558.3/10	1	camshaft
2.2	0.065.1324.0/10	1	gear Z = 32
3	0.065.1330.0	8	tappets
4	2.1559.398.0	1	bushing 10.5x13x12
5	0.013.5017.0	1	gear z=58
6	0.065.1350.0	1	small disc
7	2.0132.207.2	4	screw m 10 p.1 x 25
8	2.1410.016.1	1	circlip 40
9	0.065.1352.0	1	shim
10	0.065.1351.0	2	shoulder ring
11	0.065.1323.0/30	1	gear Z = 29
12	0.007.1177.3/20		gear z = 57 - WITH RED IDENTIFICATION STAMP
12.2	2.1559.185.0/10	1	bushing gear z = 57 - WITH YELLOW IDENTIFICATION STAMP
13	0.007.1178.3/20		gear z = 57 - WITH YELLOW IDENTIFICATION STAMP
13.2	2.1559.185.0/10	1	bushing gear z = 57 - WITH GREEN IDENTIFICATION STAMP
14	0.007.1179.3/20		gear z = 57 - WITH GREEN IDENTIFICATION STAMP
14.2	2.1559.185.0/10	1	bushing
15	2.0312.205.2	2	screw
16	2.1480.014.1	2	washer 8
17	0.065.1353.0	1	small plate

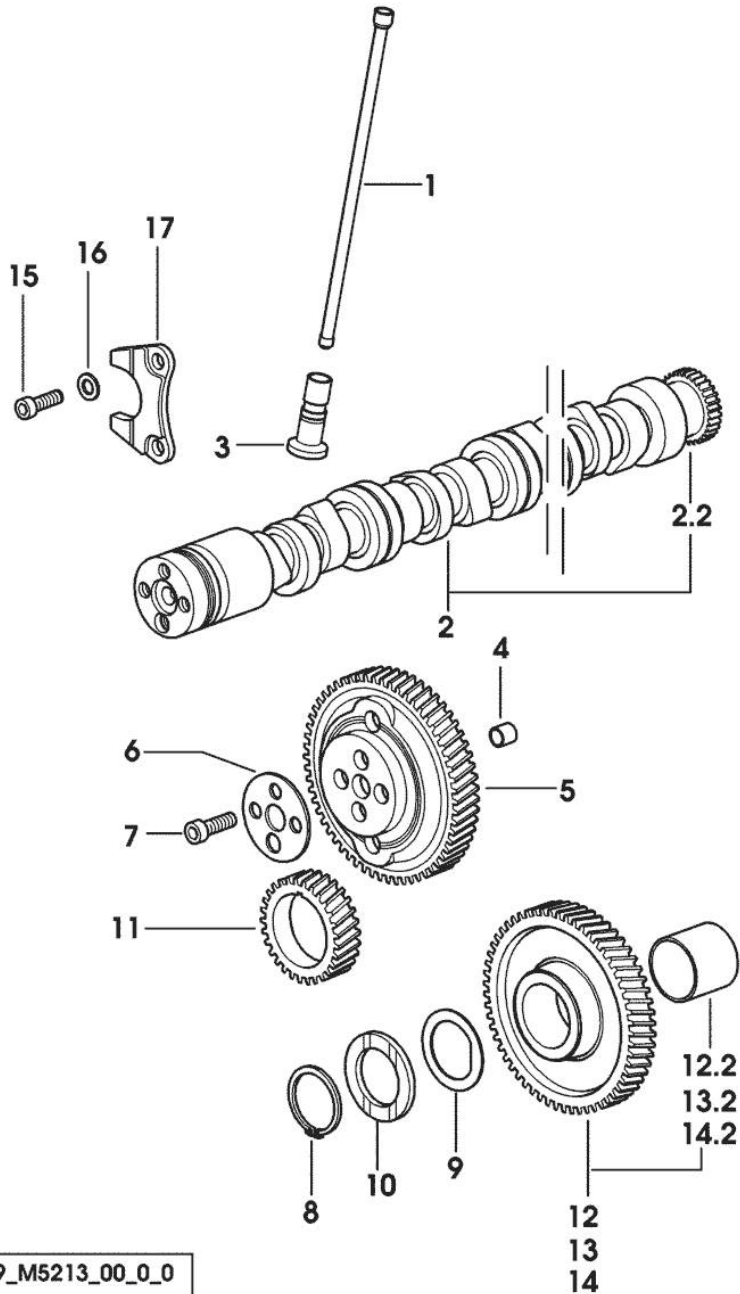

9_M5213_00_0_0

Section: ENGINE
CYLINDER HEAD

Fig.	P/n	QTY	Name
------	-----	-----	------

Notes:
[XS-90(20")]

1	2.0399.288.2/10	4	screw m 8x36x46
2	2.1539.151.0	4	special oil seal 9.19 x 2.62
3	0.007.1139.0/10	4	small cap
4	0.065.1450.0/30	1	tappet gasket
7	2.1011.421.2	8	nut m 10 p.1.25
9	0.000.0000.1		cannot be supplied
9.1	0.066.1431.0	1	pin
9.2	0.021.1434.0	2	screw
9.10	0.000.0000.1		cannot be supplied
9.10.3	2.1011.405.2	2	nut m 8 p.1
9.10.4	0.066.1432.3	2	rocker arm
9.10.4.2	2.1559.021.0/40	1	bushing 15x19x22
9.10.5	2.1410.055.7	2	circlip 19
9.10.6	0.000.0000.1		cannot be supplied
9.10.6.2	0.066.1430.0/10	1	support
9.10.7	2.1599.432.0	2	shoulder ring
16	2.1532.507.0	4	oil seal 17x3.53
17	0.012.2673.0	16	screw m 14 p.2x141
18	0.000.0000.1		cannot be supplied
18.1	0.013.0412.3/60	1	engine head
18.1.2	0.078.1426.0	1	valve seat
18.1.3	0.066.1427.0	1	valve seat
18.1.4	0.007.1779.0/20	2	valve guide
18.1.5	0.012.9984.0/20	1	bush
18.1.6	2.3170.012.1	2	expansion plug 30
18.2	0.010.6022.0	1	exhaust valve mm 39.1 / Ø mm 9
18.3	0.010.6017.0	1	inlet valve mm 43.63 / Ø mm 9
18.4	0.066.1425.0	2	cup
18.5	0.074.1423.0	4	conical valve cotter
18.6	2.4019.287.0	2	spring
18.7	2.1519.117.0	2	special oil seal
18.8	2.0432.161.7	1	stud bolt m 10 p.1.5 / p.1.25 x 40
18.9	2.0432.163.7	2	stud bolt m 10 p.1.5 / p.1.25 x 45
20	2.0432.011.7	4	stud bolt m 8 p.1.25 / p.1 x 40
21	2.0432.005.7	4	stud bolt m 8 p.1.5 / p.1 x 25
24	0.013.1887.0		gasket
25	0.013.1888.0	3	gasket
26	0.013.1889.0		gasket

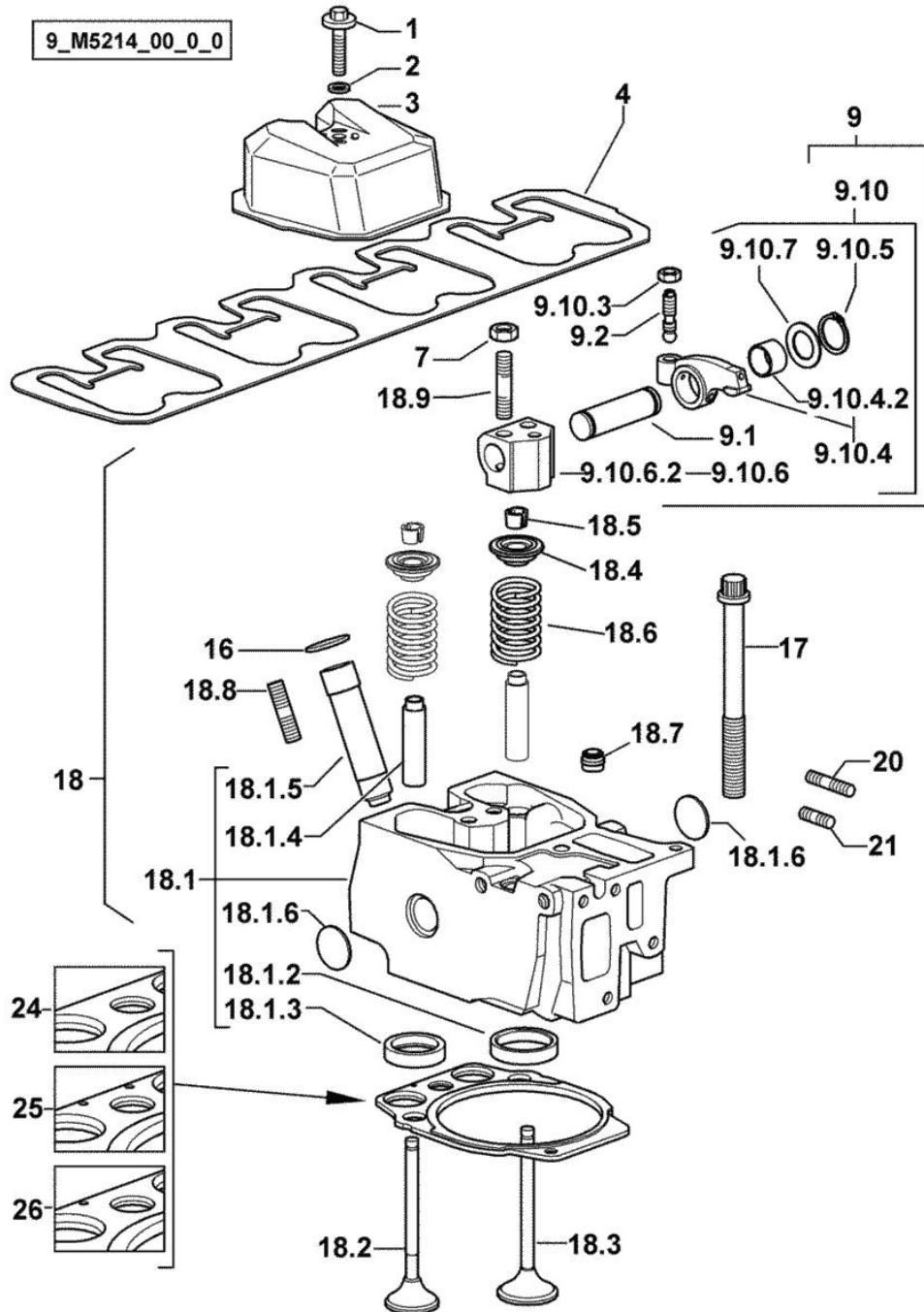



Suggest:

For more complete manuals. Please go to the home page.

<https://www.ebooklibonline.com>

If the above button click is invalid. Please download this document first, and then click the above link to download the complete manual.

Thank you so much for reading

Section: ENGINE

OIL PAN

Fig.	P/n	QTY	Name
------	-----	-----	------

Notes:
[XS-90(20")]

1	0.010.0910.0/10	1	oil sump
2	0.065.1550.0/10	1	gasket
3	2.0112.239.2	2	screw m 8 p.1.25 x 150
4	2.0112.226.2	7	screw m 8 p.1.25 x 85
5	2.0112.215.2	17	screw m 8 p.1.25 x 40
6	2.1470.004.2	27	lock washer 8
7	2.3199.001.2	3	plug 1/2" gas
8	2.1560.054.0	3	gasket 21 x 26
9	0.008.9960.0	1	tube
10	0.008.9959.3/10	1	tube
11	2.0112.209.2	1	screw m 8 p 1.25 x 25
12	2.1579.766.2	1	spacer 8.5x16x10

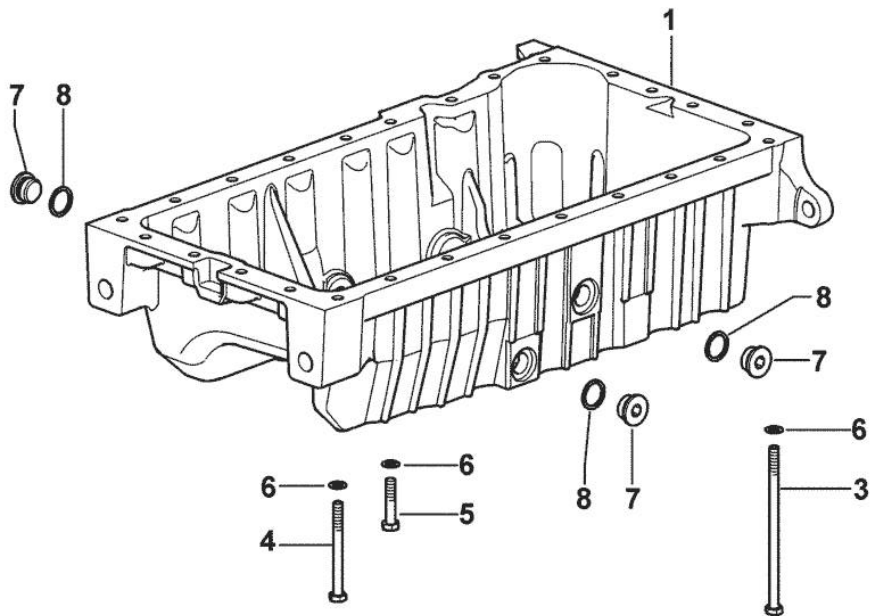
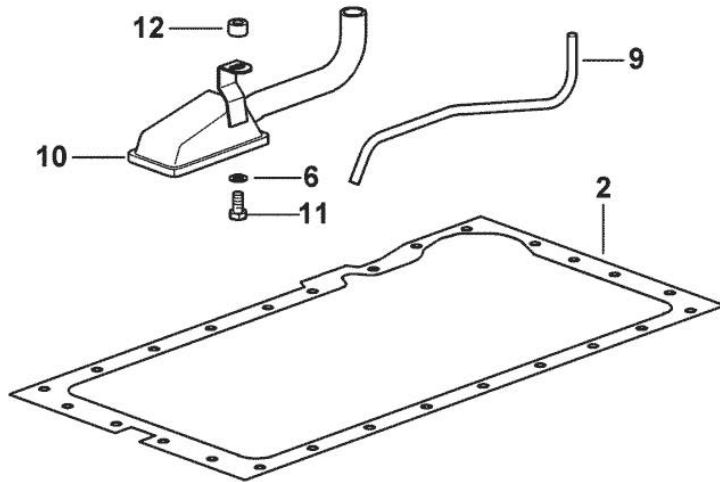

9_38715_01_0_0

Section: ENGINE

ENGINE OIL FILTER

Fig.	P/n	QTY	Name
------	-----	-----	------

Notes:
[XS-90(20")]

10	2.4419.340.0	1	oil filter element
----	--------------	---	--------------------

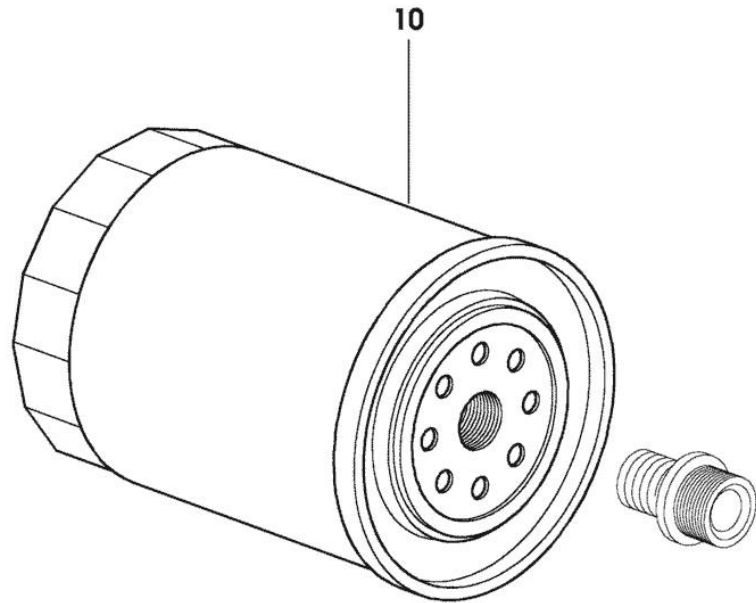

9_34415_04_0_0

<https://www.ebooklibonline.com>

Hello dear friend!

Thank you very much for reading.

Enter the link into your browser.

The full manual is available for immediate download.

<https://www.ebooklibonline.com>