

Section: ENGINE

ENGINE BEARING

Fig.	P/n	QTY	Name
------	-----	-----	------

Notes:
[XN-707]

2	2.1539.047.0	1	special oil seal 26.7x1.78
3	2.3199.405.2	1	plug m 28 p.1.5
5	2.0432.003.7	9	stud bolt m 8 p.1.25 / p.1 x 20
6	2.1559.188.2	3	bush 11.4 x 14 x16
7	2.1519.096.0/20	9	special oil seal 107.67x1.78 2683 <= X XN-706 1067 <= X XN-707
7	2.1539.193.0	6	special oil seal 107.62x2.62 => 2684 X XN-706 => 1068 X XN-707
8	2.1560.010.0	1	gasket 14.2 x 20
9	0.049.1152.0	1	cock 1026 <- X XN-706 1033 <- X XN-707
9	2.3199.292.0	1	plug 1/4" gas -> 1027 X XN-706 -> 1034 X XN-707
10	0.070.1110.6/20	1	crankcase
10.1	2.3130.001.1	9	plug 1/8" gas
10.2	2.3130.002.1	2	plug 1/4" gas
10.3	2.3130.003.1	2	plug 3/8" gas
10.4	0.000.0000.1		cannot be supplied
10.4.1	0.065.1112.7	1	support
10.4.1.2	2.1699.165.0	1	bush 12.3x15x16
10.4.2	0.065.1114.0/10	2	support
10.4.3	0.065.1116.3	1	support
10.4.3.2	2.1699.165.0	1	bush 12.3x15x16
10.4.5	0.065.1140.0	3	special bushing 59X55X20
10.4.6	0.065.1141.0	1	special bushing 59X55X30
10.4.7	0.066.1151.0	1	pin
10.4.8	0.065.1117.0	8	screw m 12 x 100
10.5	2.3179.012.0	1	plug 60
11	0.066.1152.0/10	4	gasket
14	2.1549.154.2	3	bush 4.8x5.8x16
24	2.3120.101.0	1	plug m 18 p.1.5
26	2.1560.014.0	1	washer 18.2 x 24

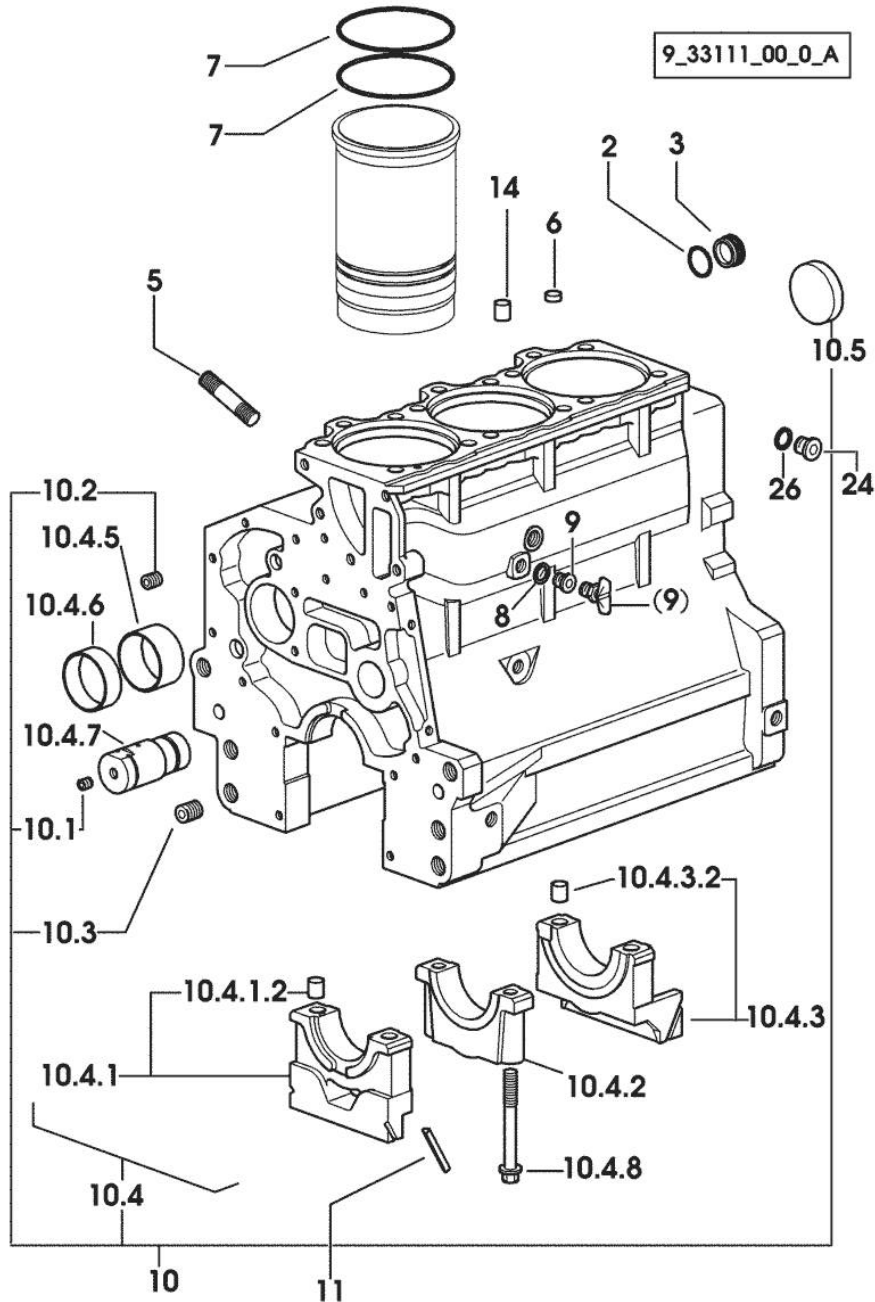

9_33111_00_0_B

XN-707

Ref: 01.00.6

Section: ENGINE

TIMING CASE

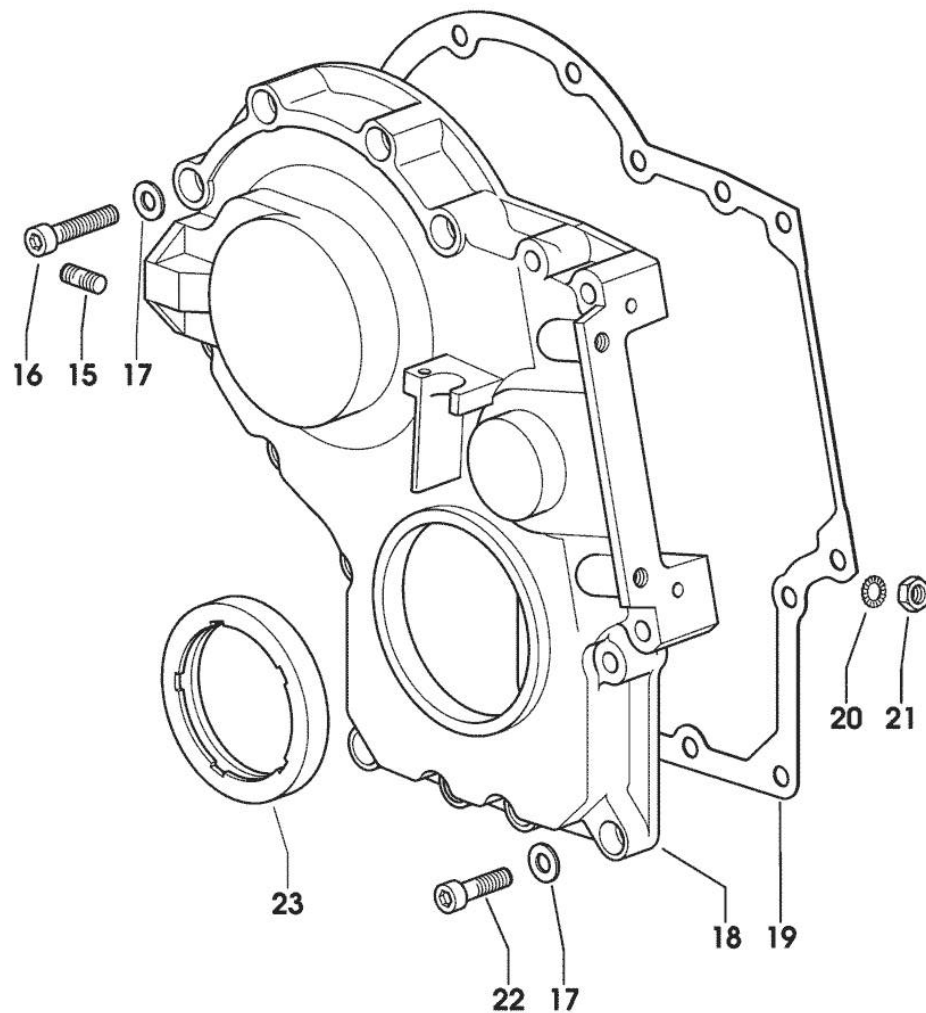

Fig.	P/n	QTY	Name
------	-----	-----	------

Notes:
[XN-707]

15	2.0432.003.7	2	stud bolt m 8 p.1.25 / p.1 x 20
16	2.0312.214.2	7	screw m 8 p.1.25 x 40
17	2.1480.014.1	15	washer 8
18	0.013.4981.0	1	guard -> 1056 X XN-706 -> 1064 X XN-707
18	0.065.1132.0/50	1	guard 1055 <- X XN-706 1063 <- X XN-707
19	0.065.1150.0/30	1	gasket
20	2.1470.004.2	4	lock washer 8
21	2.1011.405.2	2	nut m 8 p.1
22	2.0312.208.2	8	screw m 8 p.1.25 x 25
23	2.1529.141.0	1	special oil seal

Section: ENGINE
CASING COVER

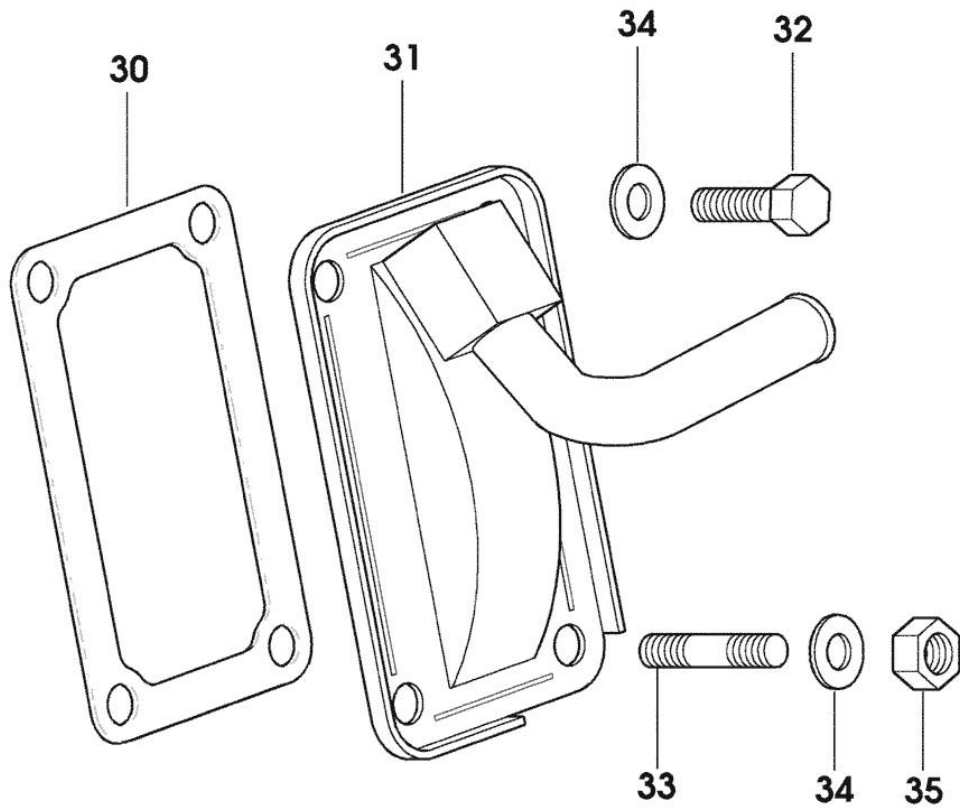

Fig.	P/n	QTY	Name
------	-----	-----	------

Notes:
[XN-707]

30	0.065.1152.0	1	gasket
31	0.010.7368.2/10	1	cover
32	2.0112.205.2	2	screw m 8 p.1.25 x 16
33	2.0432.005.7	2	stud bolt m 8 p.1.5 / p.1 x 25
34	2.1310.004.2	4	flat washer 8.4x17
35	2.1011.405.2	2	nut m 8 p.1

9_38811_01_0_0

<https://www.ebooklibonline.com>

Hello dear friend!

Thank you very much for reading.

Enter the link into your browser.

The full manual is available for immediate download.

<https://www.ebooklibonline.com>

GUARD PLATE

Fig.	P/n	QTY	Name
------	-----	-----	------

Notes:
[XN-707]

1	0.007.1262.3/50	1	guard
2	0.007.1271.0/10	1	small column m 8 p.1.25 / L = mm 60
3	0.007.1272.0/10	2	small column m 8 p.1.25 / L = mm 50
5	2.1310.004.2	3	flat washer 8.4x17
7	2.0112.203.2	3	screw m 8 p.1.25 x 12

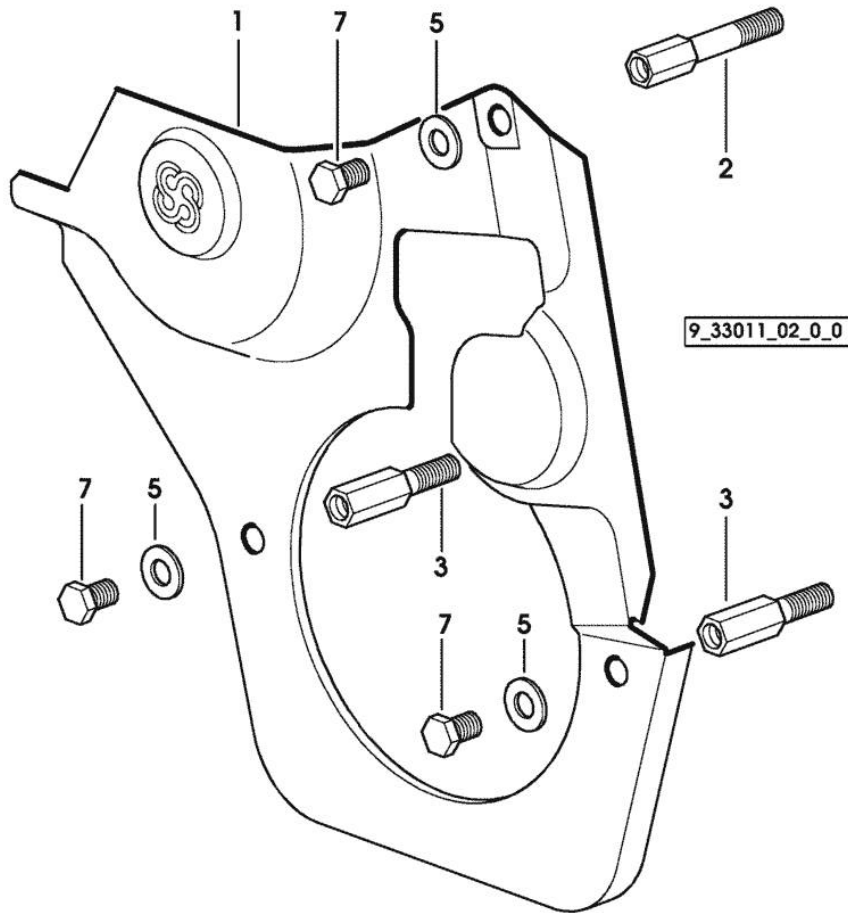

MONOBLOC ENGINE-GEARBOX CONNECTING FLANGE

Fig.	P/n	QTY	Name
------	-----	-----	------

Notes:
[XN-707]

1	0.007.1882.0/50	1	flange
2	2.0112.511.2	8	screw m 14 p.2 x 30
3	2.1651.912.0	2	cylindrical plug 12x28
4	2.1651.917.0	1	cylindrical plug 12x40
5	2.0432.255.7	2	stud bolt m 12 p.1.75-1.25x25 1062 <- X XN-706 1076 <- X XN-707 1101 <- X XN-708 1034 <- X XN-709
5	2.0432.257.7	1	stud bolt m 12 p.1.75 - 1.25 x 30 -> 1063 X XN-706 -> 1077 X XN-707 -> 1102 X XN-708 -> 1035 X XN-709
6	2.0439.250.7	1	stud bolt m 12 / m 10 x 30 -> 1063 X XN-706 -> 1077 X XN-707 -> 1102 X XN-708 -> 1035 X XN-709
7	0.011.9294.0/10	1	bush -> 1063 X XN-706 -> 1077 X XN-707 -> 1102 X XN-708 -> 1035 X XN-709

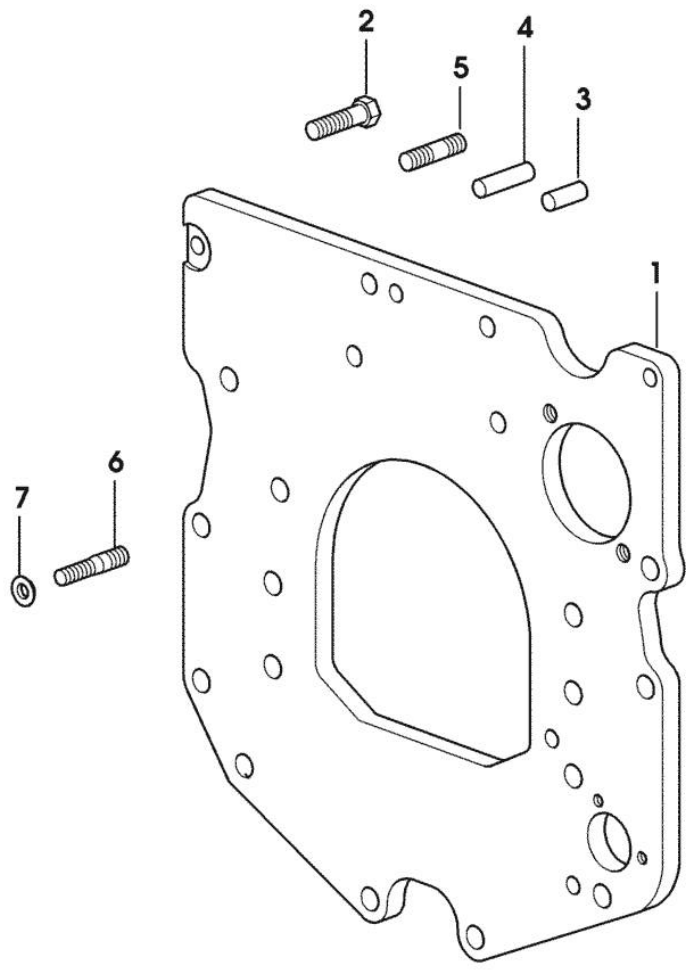

9_38611_01_0_0

Section: ENGINE
CRANKSHAFT

9_34812_00_0_0

Fig.	P/n	QTY	Name
------	-----	-----	------

Notes:
[XN-707]

4	2.3130.001.1	3	plug 1/8" gas
6	2.1720.006.0	2	key 4x6.5
7	0.007.1554.0/20	1	crankshaft
8	0.065.1215.0	4	main half bushing STANDARD
8	0.065.1215.7		main half bushing - mm 0.25
8	0.065.1215.8		main half bushing - mm 0.50
9	0.065.1216.0	4	main half bushing
9	0.065.1216.7		main half bushing - mm 0.25
9	0.065.1216.8		main half bushing - mm 0.50
10	0.065.1218.0	4	shim STANDARD
10	0.065.1218.7		shim + mm 0.10
10	0.065.1218.8		shim + mm 0.15
15	0.065.1254.0/20	1	gasket
16	0.007.1711.0/10	1	cover
17	2.1475.002.2	9	conical washer 8
18	2.0112.207.2	9	screw m 8 p 1.25 x 20
19	2.1529.073.0	1	special oil seal 110x130x13
20	2.1651.915.0	1	pin 12x35
22	2.1599.524.7	1	washer 21x60x12

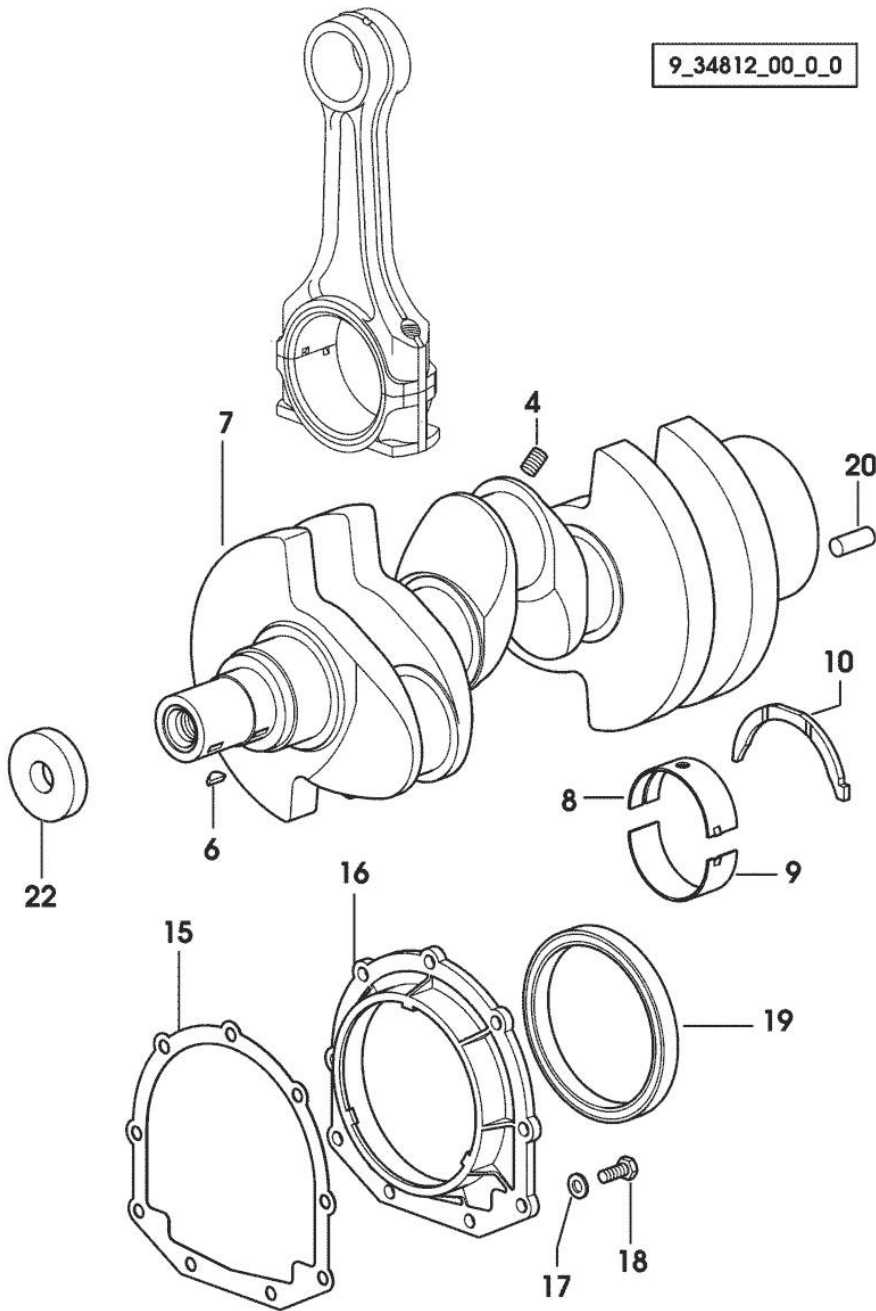

CYLINDER - PISTON - CONNECTING ROD

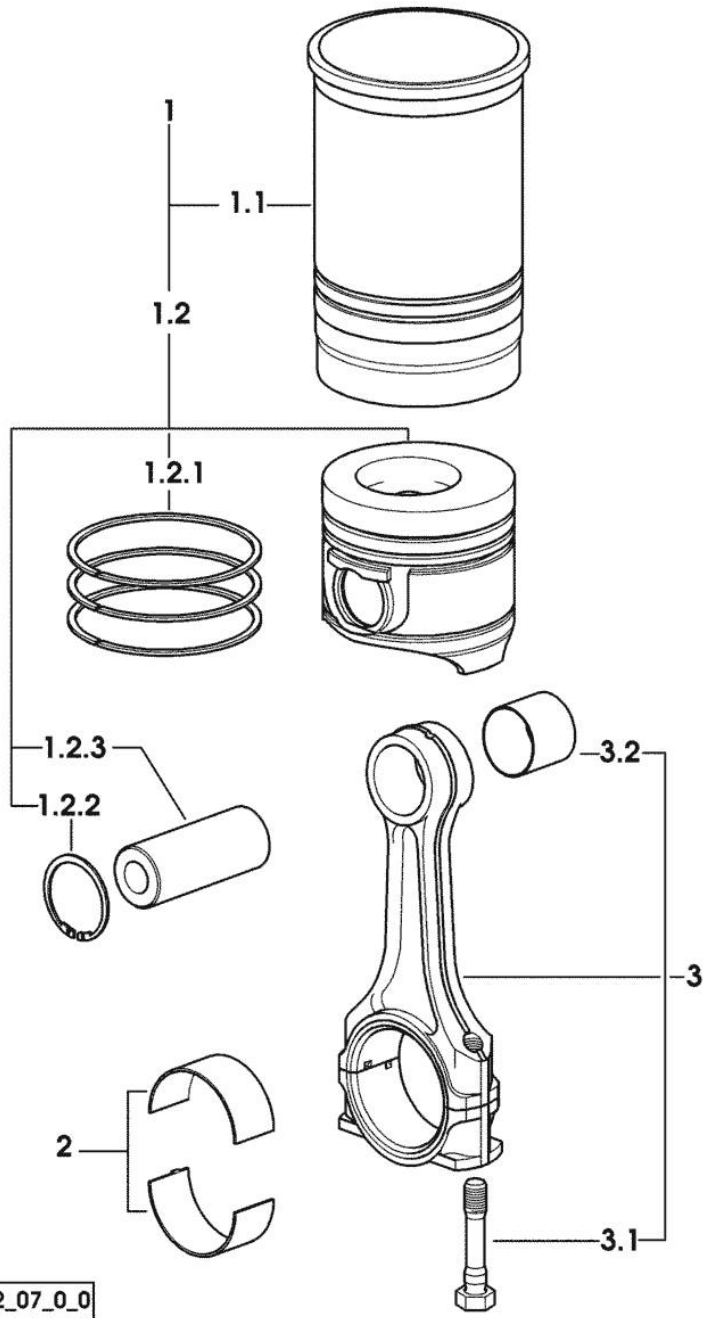

Fig.	P/n	QTY	Name
------	-----	-----	------

Notes:
[XN-707]

1	0.388.0065.6	3	cyl. piston assembly 1067 <= X XN-707
1	0.388.0065.A	3	cyl. piston assembly "A" => 1068 X XN-707 - CLASS A
1	0.388.0065.B	3	cyl. piston assembly "B" => 1068 X XN-707 - CLASS B
1.1	0.011.0183.0/20	1	engine cylinder
1.1	0.011.0582.0	1	engine cylinder 1067 <= X XN-707
1.1	0.A12.2675.0	1	engine cylinder "A" => 1729 X XN-707 - CLASS A
1.1	0.B12.2675.0	1	engine cylinder "B" => 1729 X XN-707 - CLASS B
1.2	0.381.0060.6/10	1	complete piston 1728 <= X XN-707
1.2	0.381.0060.A	1	complete piston "A" => 1729 X XN-707 - CLASS A
1.2	0.381.0060.B	1	complete piston "B" => 1729 X XN-707 - CLASS B
1.2.1	0.338.0052.6/20	1	piston ring set
1.2.2	2.1411.014.1	2	circlip 35
1.2.3	0.078.1236.0	1	piston pin Ø 18 / Ø 35 / L = mm 86
2	0.065.1225.0	6	con.rod half bushing STANDARD - A = 28.75 -> 29.00
2	0.065.1225.7	6	con.rod half bushing - mm 0.25
2	0.065.1225.8	6	con.rod half bushing - mm 0.50
3	0.078.1220.3/30	3	engine connecting rod
3.1	2.0399.213.0	2	screw m 12 p.1.25x61.5
3.2	2.1559.114.0/10	1	special bushing

9_38612_07_0_0

CRANKSHAFT PULLEY

Fig.	P/n	QTY	Name
------	-----	-----	------

Notes:
[XN-707]

3	0.007.1457.0/30	1	pulley
5	0.085.1248.0/10	1	hub
6	2.0399.144.7/10	1	screw m 20 p.1.5x51
8	2.1720.006.0	1	key 4x6.5

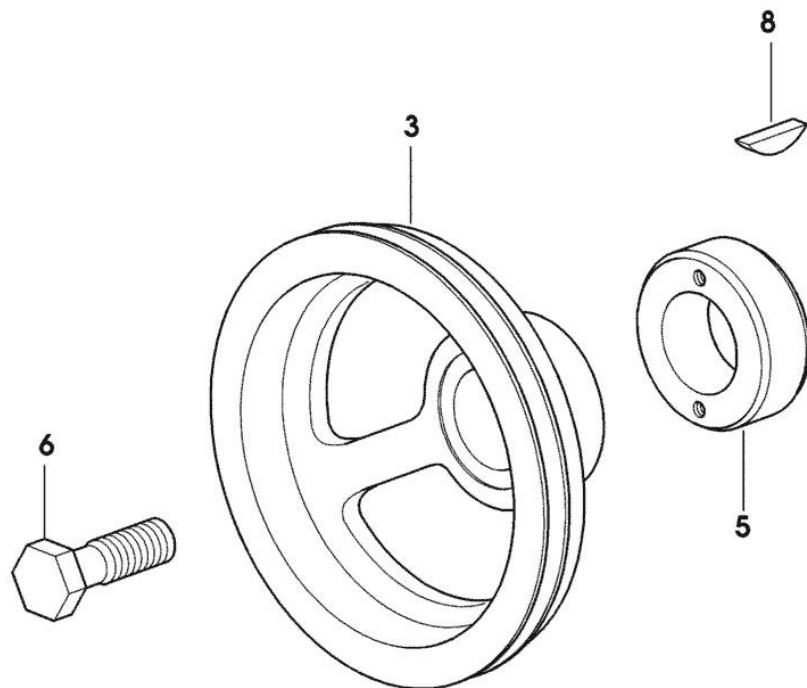

9_33312_02_0_0

ENGINE SHAFT - FRONT P.T.O. PULLEYS

Fig.	P/n	QTY	Name
------	-----	-----	------

Notes:
[XN-707]

1	0.010.4910.0	1	pulley
2	0.011.3515.0/10	1	hub Z = 48
3	0.065.1256.0	2	ring 45x52
4	2.1579.865.0	1	spacer 45.2x51.8x10
5	2.0439.195.7	1	stud bolt m 20 p.1.5x80
6	2.1019.094.7	1	nut m 20 p.1.5

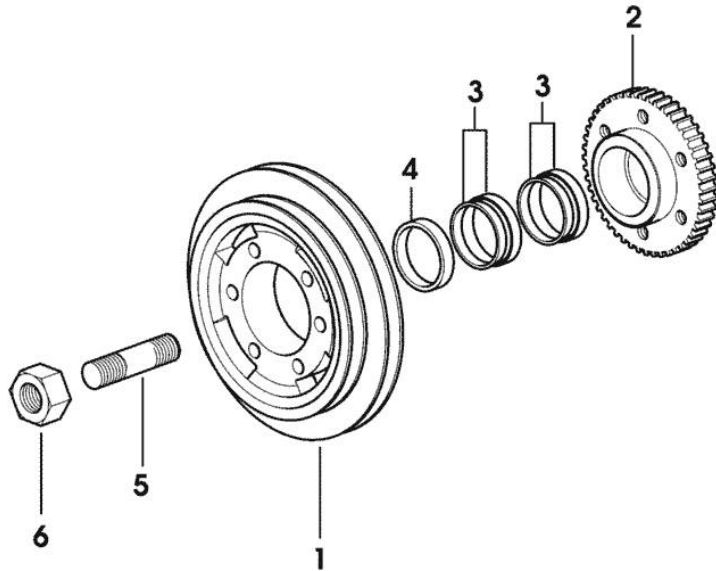

9_38912_08_0_0

PULSE WHEEL

Fig.	P/n	QTY	Name
------	-----	-----	------

Notes:
[XN-707]

1	0.011.3531.0	1	gear Z = 48
---	--------------	---	-------------

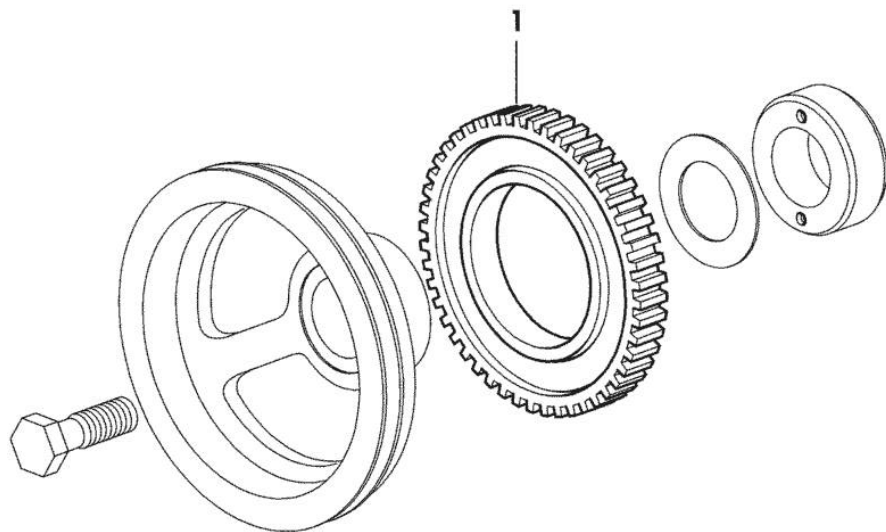

9_36812_05_0_0

FLYWHEEL

Fig.	P/n	QTY	Name
------	-----	-----	------

Notes:
[XN-707]

1	0.007.1883.3/10	1	flywheel
1.2	0.069.1242.0	1	crown wheel Z = 121
2	0.255.2525.0/10	1	flange
3	2.0139.022.2	6	screw m 12 p.1.25x55

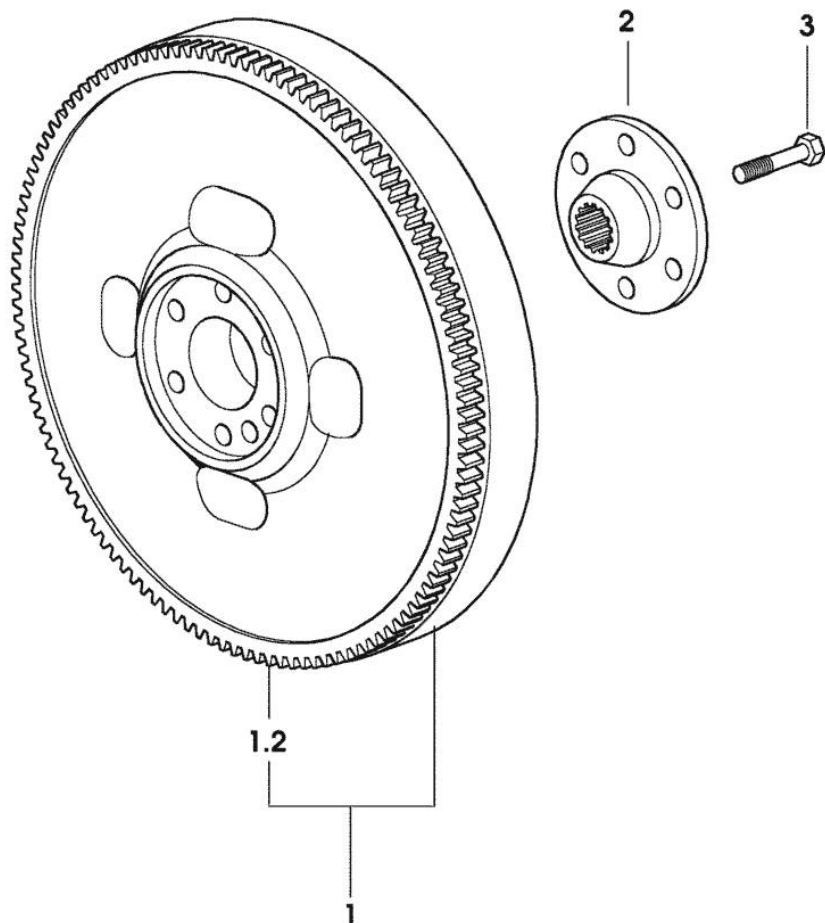

9_37212_08_0_0

FLYWHEEL

Fig.	P/n	QTY	Name
------	-----	-----	------

Notes:
[XN-707]

50	0.011.2162.3	1	flywheel
50.2	0.069.1242.0	1	crown wheel Z = 121
51	0.255.2525.0/10	1	flange
52	2.0139.022.2	6	screw m 12 p.1.25x55

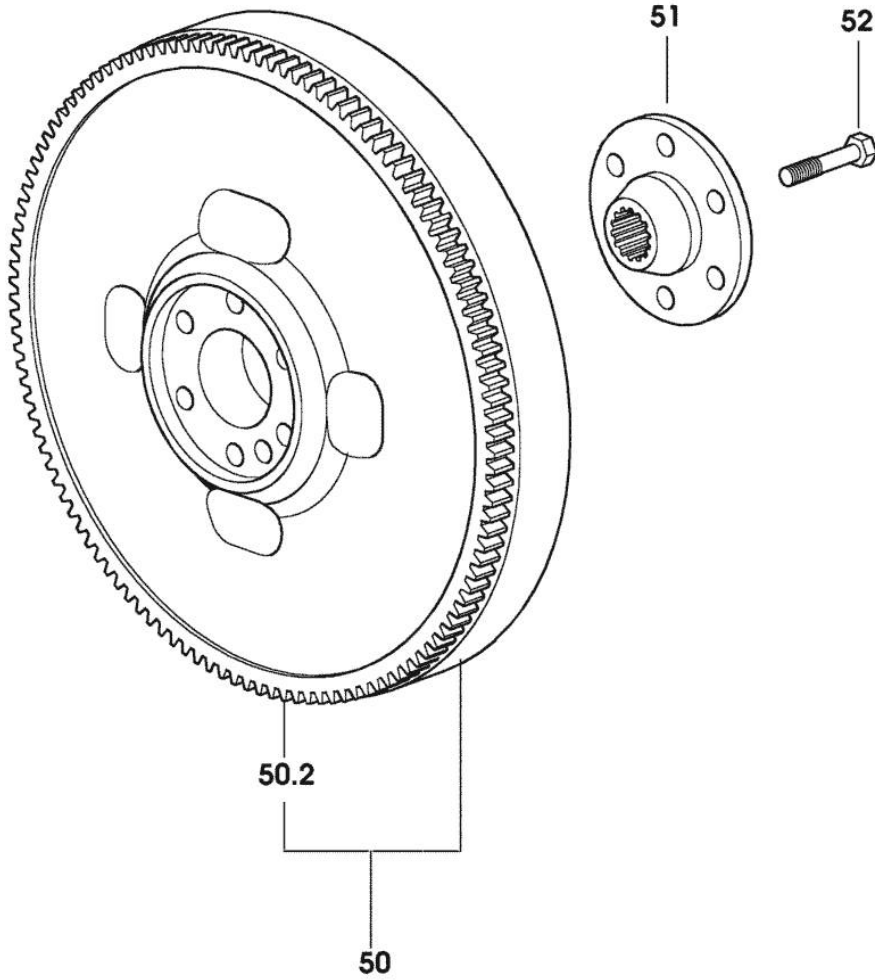

9_37412_01_0_0

Section: ENGINE

CAMSHAFT

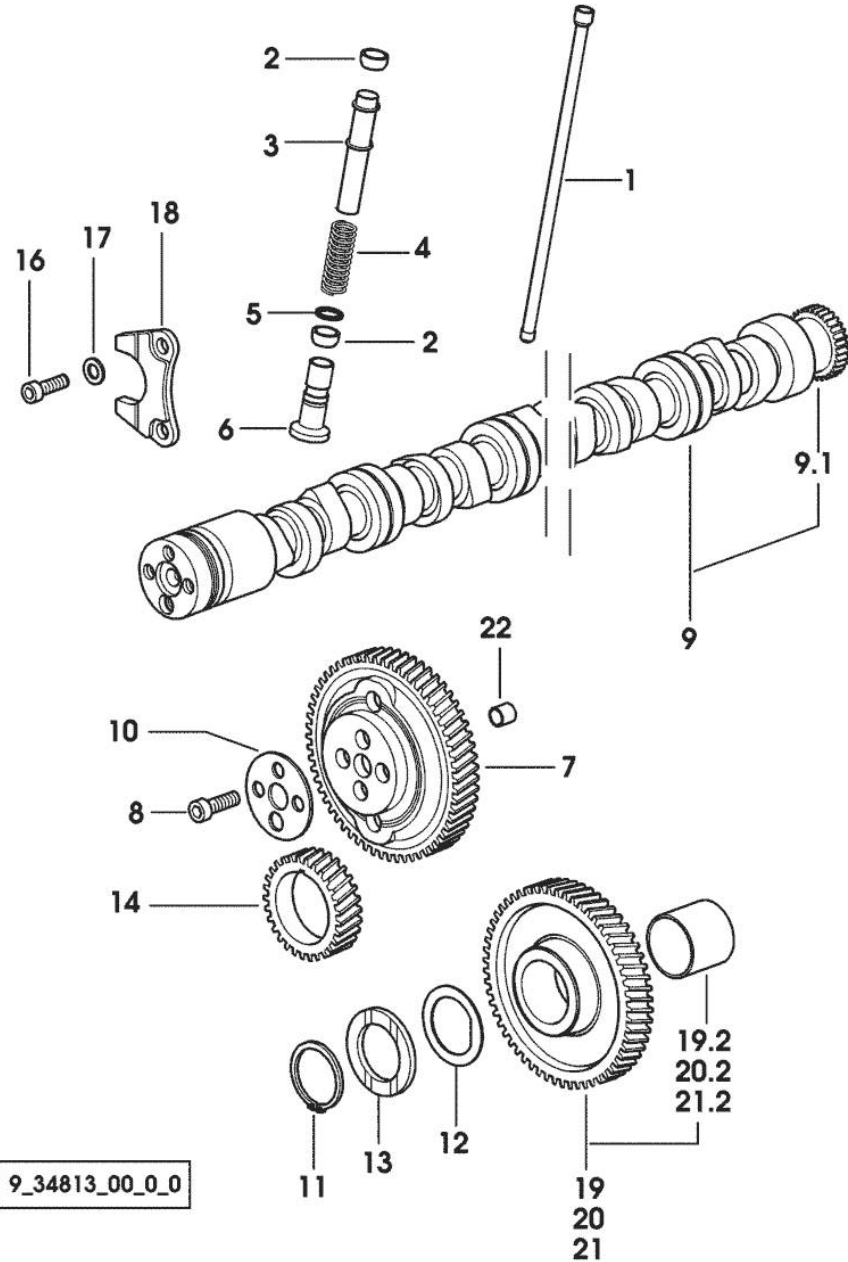

Fig.	P/n	QTY	Name
------	-----	-----	------

Notes:
[XN-707]

1	0.065.1331.2	6	rod
2	2.1569.114.0/10	12	gasket 14x18.5x8
3	0.065.1332.0	6	sleeve
4	2.4019.300.1/10	6	spring 18.5x52x2
5	2.1599.437.0	6	shoulder ring
6	0.065.1330.0	6	tappets
7	0.065.1354.0/20	1	gear z=58
8	2.0132.207.2	4	screw m 10 p.1 x 25
9	0.070.1310.3/40	1	camshaft
9.1	0.065.1324.0/10	1	gear Z = 32
10	0.065.1350.0	1	small disc
11	2.1410.016.1	1	circlip 40
12	0.065.1352.0	1	shim
13	0.065.1351.0	2	shoulder ring
14	0.065.1323.0/30	1	gear Z = 29
16	2.0312.205.2	2	screw
17	2.1480.014.1	2	washer 8
18	0.065.1353.0	1	small plate
19	0.007.1177.3/20		gear z = 57 - WITH RED IDENTIFICATION STAMP
19.2	2.1559.185.0/10	1	bushing gear z = 57
20	0.007.1178.3/20		- WITH YELLOW IDENTIFICATION STAMP
20.2	2.1559.185.0/10	1	bushing
21	0.007.1179.3/20	1	gear z = 57 - WITH GREEN IDENTIFICATION STAMP
21.2	2.1559.185.0/10	1	bushing
22	2.1559.398.0	1	bushing 10.5x13x12 -> 1048 X XN-706 -> 1051 X XN-707



Suggest:

For more complete manuals. Please go to the home page.

<https://www.ebooklibonline.com>

If the above button click is invalid. Please download this document first, and then click the above link to download the complete manual.

Thank you so much for reading

Section: ENGINE

CAMSHAFT

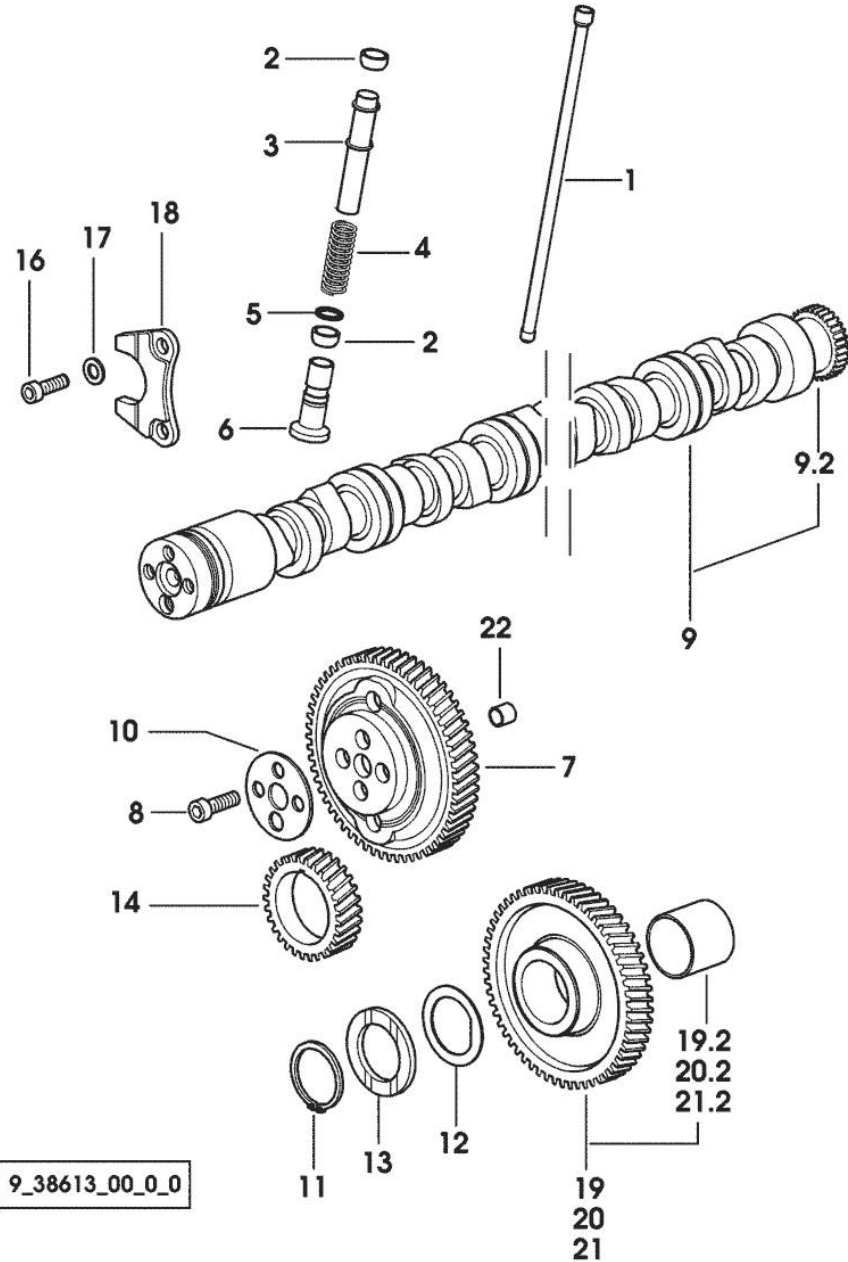

9_38613_00_0_0

Fig.	P/n	QTY	Name
------	-----	-----	------

Notes:
[XN-707]

1	0.065.1331.2	6	rod
2	2.1569.114.0/10	12	gasket 14x18.5x8
3	0.065.1332.0	6	sleeve
4	2.4019.300.1/10	6	spring 18.5x52x2
5	2.1599.437.0	6	shoulder ring
6	0.065.1330.0	6	tappets
7	0.065.1354.0/20	1	gear z=58
8	2.0132.207.2	4	screw m 10 p.1 x 25
9	0.009.7456.3/10	1	camshaft
9.2	0.065.1324.0/10	1	gear Z = 32
10	0.065.1350.0	1	small disc
11	2.1410.016.1	1	circlip 40
12	0.065.1352.0	1	shim
13	0.065.1351.0	2	shoulder ring
14	0.065.1323.0/30	1	gear Z = 29
16	2.0312.205.2	2	screw
17	2.1480.014.1	2	washer 8
18	0.065.1353.0	1	small plate
19	0.007.1177.3/20		gear z = 57 - WITH RED IDENTIFICATION STAMP
19.2	2.1559.185.0/10	1	bushing
20	0.007.1178.3/20		gear z = 57 - WITH YELLOW IDENTIFICATION STAMP
20.2	2.1559.185.0/10	1	bushing
21	0.007.1179.3/20	1	gear z = 57 - WITH GREEN IDENTIFICATION STAMP
21.2	2.1559.185.0/10	1	bushing
22	2.1559.398.0	1	bushing 10.5x13x12 -> 1048 X XN-706 -> 1051 X XN-707

Section: ENGINE
CYLINDER HEAD

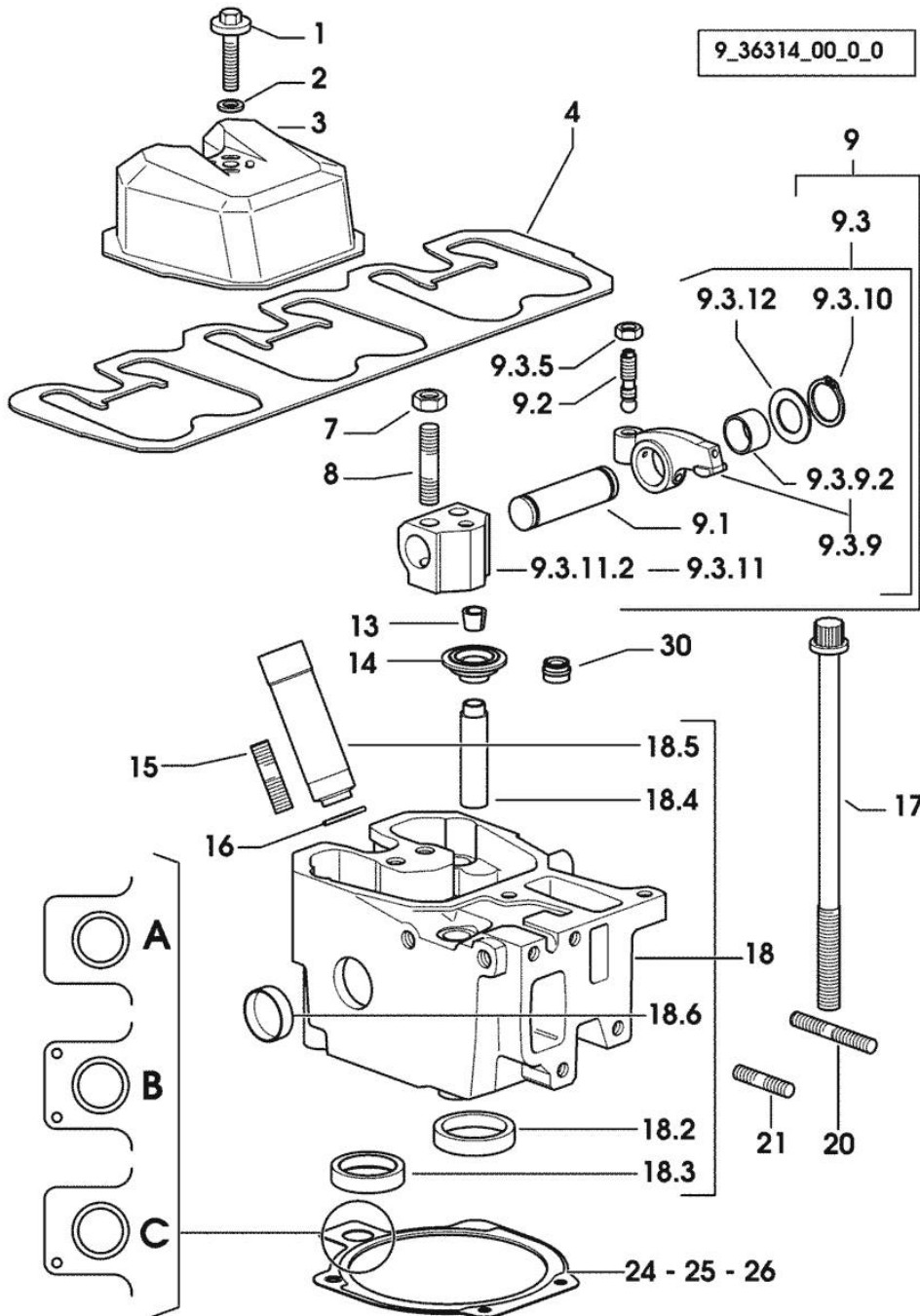

Fig.	P/n	QTY	Name
Notes: [XN-707]			
1	2.0399.130.2/10	3	screw m 8x36x44 1114 <- X XN-707
1	2.0399.288.2/10	3	screw m 8x36x46 -> 1115 X XN-707
2	2.1539.151.0	3	special oil seal 9.19 x 2.62 -> 1115 X XN-707
2	2.1569.170.0/10	3	gasket 8.2 x 14 1114 <- X XN-707
3	0.007.1139.0/10	3	small cap
4	0.069.1450.0/30	1	tappet gasket
7	2.1011.421.2	6	nut m 10 p.1.25
8	2.0432.163.7	6	stud bolt m 10 p.1.5 / p.1.25 x 45
9	0.000.0000.1		cannot be supplied
9.1	0.066.1431.0	1	pin
9.2	0.021.1434.0	2	screw
9.3	0.000.0000.1		cannot be supplied
9.3.5	2.1011.405.2	2	nut m 8 p.1
9.3.9	0.066.1432.3	2	rocker arm
9.3.9.2	2.1559.021.0/40	1	bushing 15x19x22
9.3.10	2.1410.055.7	2	circlip 19
9.3.11	0.000.0000.1		cannot be supplied
9.3.11.2	0.066.1430.0/10	1	support
9.3.12	2.1599.432.0	2	shoulder ring
13	0.074.1423.0	12	conical valve cotter
14	0.066.1425.0	6	cup
15	2.0432.161.7	3	stud bolt m 10 p.1.5 / p.1.25 x 40
16	2.1530.051.0	3	oil seal 20.22x3.53 -> 1041 X XN-707
16	2.1530.056.0	3	oil seal 21.82 x 3.53 1040 <- X XN-707
17	0.012.2673.0	12	screw m 14 p.2x141 -> 1096 X XN-707
17	0.066.1443.0/10	12	screw 1095 <- X XN-707
18	0.007.1360.3/60	3	head
18.2	0.078.1426.0	1	valve seat
18.3	0.066.1427.0	1	valve seat
18.4	0.007.1779.0/10	2	valve guide
18.5	0.010.6041.0	1	bush
18.6	2.3170.012.1	2	expansion plug 30
20	2.0432.011.7	3	stud bolt m 8 p.1.25 / p.1 x 40

<https://www.ebooklibonline.com>

Hello dear friend!

Thank you very much for reading.

Enter the link into your browser.

The full manual is available for immediate download.

<https://www.ebooklibonline.com>