

**REAR AXLE - MOUNTINGS SX/LH/LI - DX/RH/RE**

Fig.	P/n	QTY	Name
------	-----	-----	------

**Notes:**

[XM 100 T4i HI-LEVEL]

1	2.0422.435.7	8	stud bolt m 12 x 200
2	2.1475.004.7	24	washer 13 x 24
3	2.1011.107.2	14	nut m 12 p.1.75
4	2.0112.444.2	10	screw m 12 p.1.75x180
5	2.0422.434.7	6	stud bolt m 12 p.1.75x190

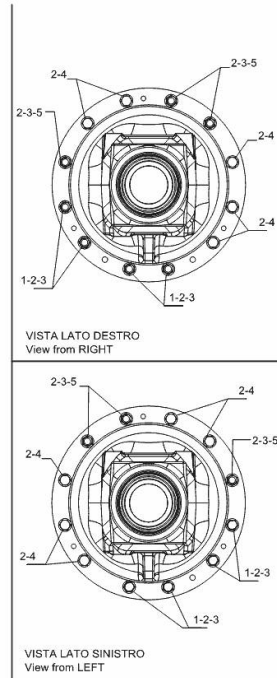
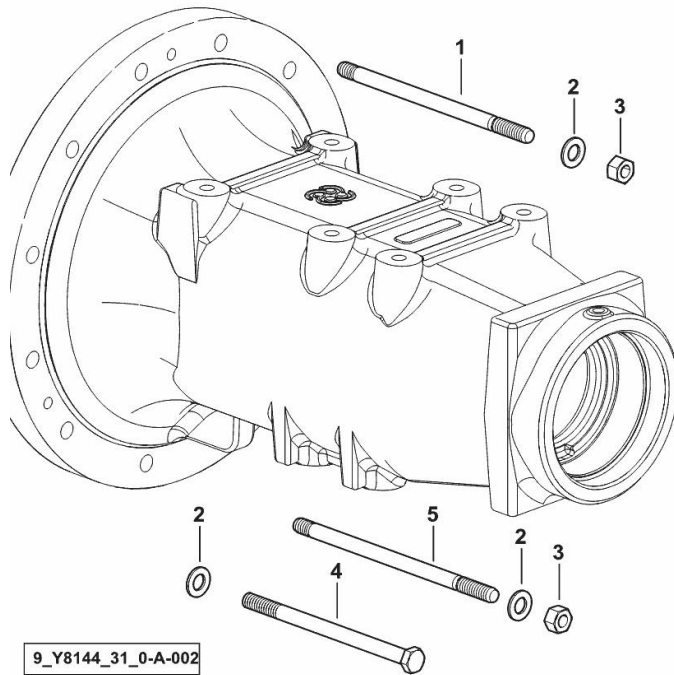

**4-PLANET PINION DIFFERENTIAL**

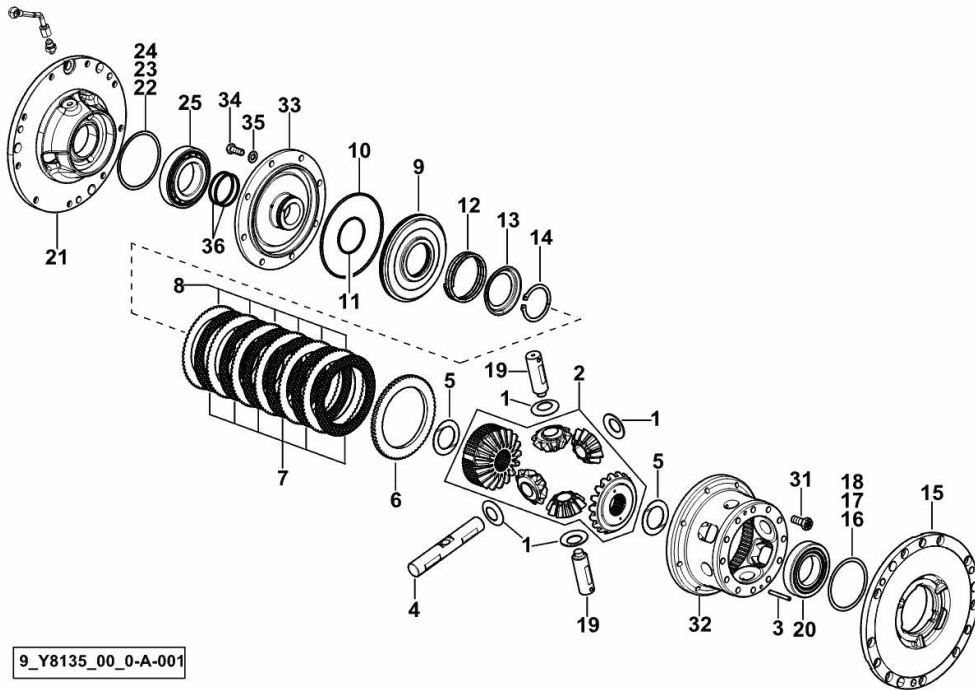

9\_Y8135\_00\_0-A-001

Fig.	P/n	QTY	Name
------	-----	-----	------

Notes:

[XM 100 T4i HI-LEVEL]

1	0.157.3550.0	4	shoulder ring
2	0.011.7161.3	1	crown wheel
3	2.1631.519.0	2	roll pin 6x50
4	0.010.0614.0/10	1	pin
5	2.1599.427.0/10	2	shoulder ring 42x64x0.3
6	0.008.5908.0	1	spacer
7	0.010.5034.2	6	disc mm 2.50
8	0.010.0711.0	6	disc mm 1.75
9	0.010.4853.0/10	1	piston
10	2.1539.094.0	1	special oil seal 151.99x3.53
11	0.005.8281.0	1	oil seal 61.6x2.62
12	0.008.4346.2	1	spring
13	0.008.4344.0	1	cup
14	2.1410.024.1	1	circlip Ø 60 mm
15	0.015.2833.0/20	1	flange sx/lh/li
16	2.1580.319.0	5	shim 86x98x0.5
17	2.1580.320.0	2	shim 86x98x0.2
18	2.1580.321.0	2	shim 86x98x0.05
19	0.010.0613.0	2	pin
20	2.2520.012.0	1	roller bearing iso 55 kb 02
21	0.015.6692.0/10	1	flange
22	2.1580.305.0	2	shim 97x108x0.2
23	2.1580.306.0	2	shim 97x108x0.5
24	2.1580.312.0	2	shim 97x108x0.05
25	2.2520.013.0	1	roller bearing iso 60 kb 02
31	2.0129.028.2	12	screw m 12 p.1.25x30
32	0.010.0549.0/20	1	differential carrier
33	0.008.5909.3/30	1	cover
34	2.0112.309.2	8	screw m 10 p.1.5 x 25
35	2.1475.003.2	8	washer 10
36	0.164.3646.0	2	piston ring

Fig.	P/n	QTY	Name
------	-----	-----	------

Notes:  
 [XM 100 T4i HI-LEVEL]

2	2.1599.543.0	1	spacer 86x98x5
---	--------------	---	----------------

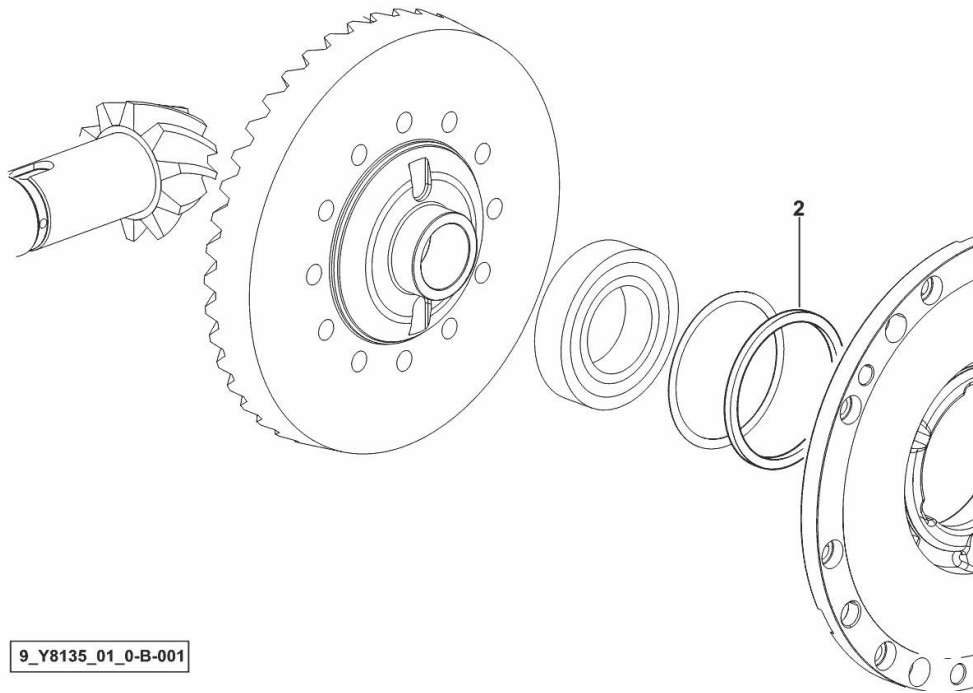

**<https://www.ebooklibonline.com>**

Hello dear friend!

Thank you very much for reading.

Enter the link into your browser.

The full manual is available for immediate download.

**<https://www.ebooklibonline.com>**

**REAR REDUCTION GEARS AND AXLE SHAFTS SX/LH/LI - DX/RH/RE**

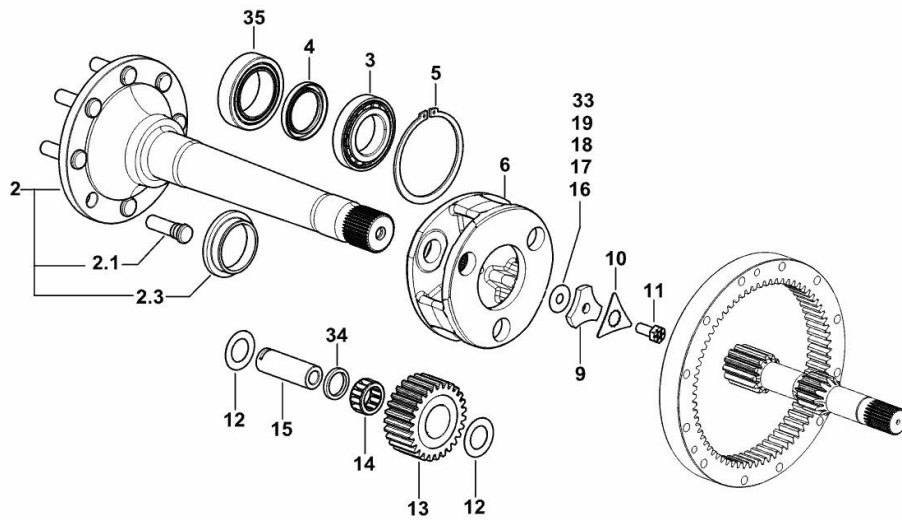

9\_J1547\_30\_0-B-001

Fig.	P/n	QTY	Name
<b>Notes:</b>			
[XM 100 T4i HI-LEVEL]			
2	0.015.3262.3/10	2	half-shaft
2.1	0.148.4737.0/20	8	small column m 20x68
2.3	0.008.4226.0/10	1	spacer
3	2.2520.013.0	2	roller bearing iso 60 kb 02
4	2.1510.331.0	2	oil seal 60x85x10
5	2.1410.045.1	2	circlip 125
6	0.008.5581.0/10	2	differential carrier
9	0.255.4745.0/10	2	spacer
10	0.008.5605.0	2	washer
11	2.0139.041.1	2	screw m 14 p.1.5 x 33
12	2.1589.170.0	12	shoulder ring 35x58x1
13	0.008.5582.0	6	planet gear
14	2.2999.197.0	6	roller cage
15	0.445.4725.0	6	pin
16	2.1589.106.0	6	shoulder ring 14.5 x 41 x 1.0
17	2.1589.107.0	2	shoulder ring 14.5 x 41 x 0.5
18	2.1589.108.0	2	shoulder ring 14.5 x 41 x 0.2
19	2.1589.109.0	2	shoulder ring 14.5 x 41 x 0.1
33	2.1589.246.0	2	shoulder ring 14.5 x 41 x 0.15
34	2.1549.138.0	6	spacer
35	2.2999.227.0	2	special bearing 70x110x31

**HALF AXLES**

Fig.	P/n	QTY	Name
------	-----	-----	------

**Notes:**

[XM 100 T4i HI-LEVEL]

1	0.015.3705.0/10	1	half-shaft sx/lh/li
2	0.015.3703.0	1	half-shaft dx/rh/re

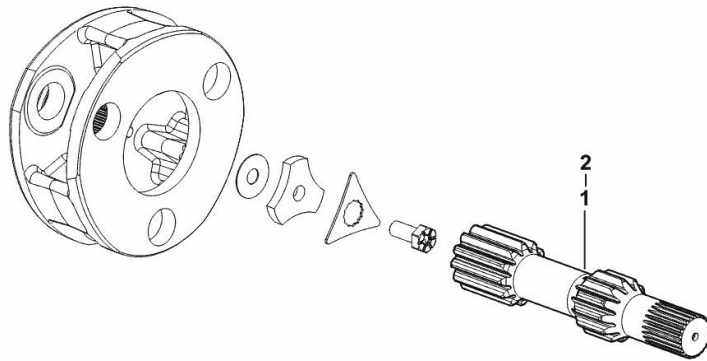

9\_J1547\_31\_0-A-001

**REAR WHEEL HUB COVER**

Fig.	P/n	QTY	Name
------	-----	-----	------

**Notes:**

[XM 100 T4i HI-LEVEL]

1	0.019.4336.3	2	small cover SX/LH/LI - DX/RH/RE
2	0.019.5747.3	2	bracket
3	2.1310.002.2	4	flat washer 6.4x12.5
4	2.0112.005.2	4	screw m 6 p.1 x 16

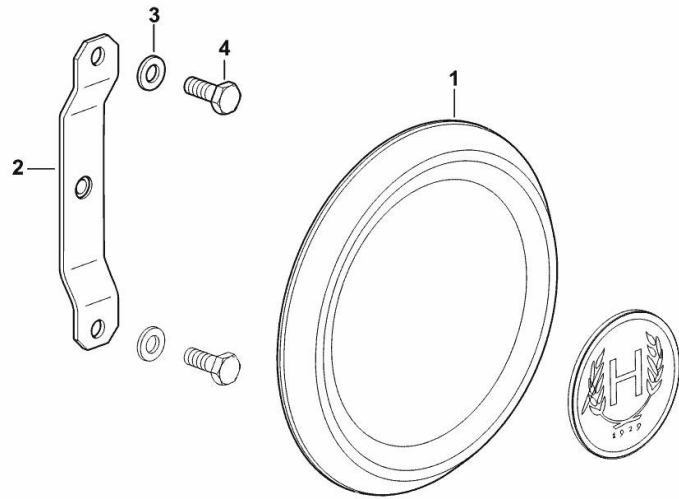

9\_Y7147\_35\_0-B-001

**REAR BRAKES WITH 0.55 mm WEAR ADJUSTMENT**

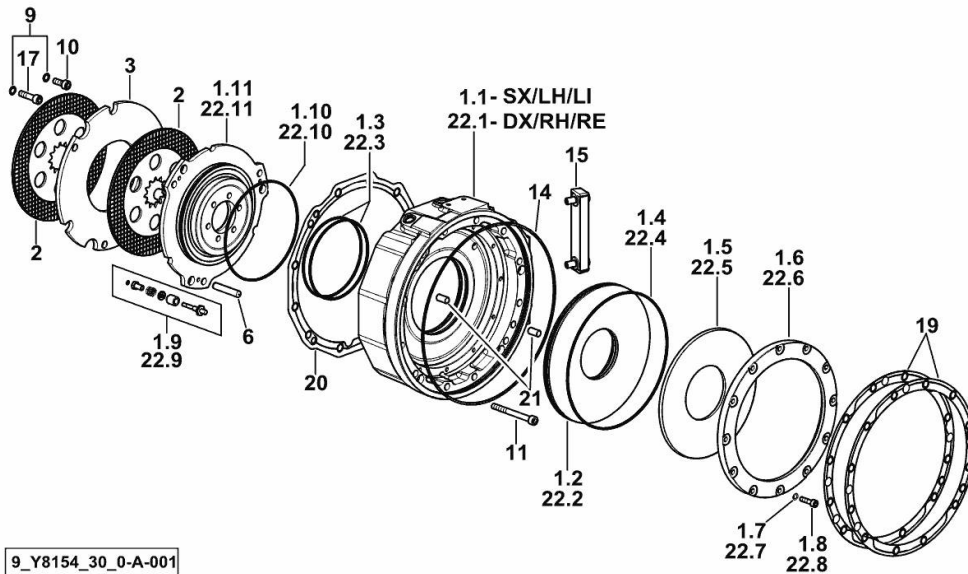

9\_Y8154\_30\_0-A-001

Fig.	P/n	QTY	Name
<b>Notes:</b>			
[XM 100 T4i HI-LEVEL]			
1.1	0.021.2415.0/20	1	flange SX/LH/LI
1.2	0.018.9211.0	1	piston
1.3	2.1532.253.0	2	oil seal 148.82x3.53
1.4	2.1532.308.0	1	oil seal 253.59x3.53
1.5	2.1499.244.0	1	spring 250x105
1.6	0.015.2815.0/10	1	ring
1.7	2.1480.014.2	12	washer 8
1.8	2.0314.210.2	12	screw m 8 x 30
1.9	0.018.7891.4	3	device
1.10	2.1532.279.0	1	oil seal 183.74x3.53
1.11	0.015.2798.0/30	1	piston
2	0.016.3140.2	4	brake disc D=243
3	0.015.2805.0/20	2	spacer
6	2.1655.617.0	6	pin 12x65
9	2.1480.015.2	18	washer 10
10	2.0312.308.2	16	screw m 10 p.1.5 x 25
11	2.0312.326.2	8	screw m 10 p.1.5x100
14	2.1539.518.0	2	special oil seal 343x3.53
15	0.015.8160.0	1	level indicator
17	2.0312.314.2	2	screw m 10 p.1.5 x 40
19	0.017.1697.0/10	4	gasket
20	0.017.2401.0	2	gasket
21	2.1655.608.0	4	pin 12 x 24
22.1	0.019.6746.0/20	1	flange DX/RH/RE
22.2	0.018.9211.0	1	piston
22.3	2.1532.253.0	2	oil seal 148.82x3.53
22.4	2.1532.308.0	1	oil seal 253.59x3.53
22.5	2.1499.244.0	1	spring 250x105
22.6	0.015.2815.0/10	1	ring
22.7	2.1480.014.2	12	washer 8
22.8	2.0313.210.7	12	screw m 8 x 30
22.8	2.0314.210.2	12	screw m 8 x 30
22.9	0.018.7891.4	3	device
22.10	2.1532.279.0	1	oil seal 183.74x3.53
22.11	0.015.2798.0/30	1	piston

**PLUG**

Fig.	P/n	QTY	Name
------	-----	-----	------

Notes:  
[XM 100 T4i HI-LEVEL]

1	2.3121.005.2	2	plug m 16 p.1.5
---	--------------	---	-----------------

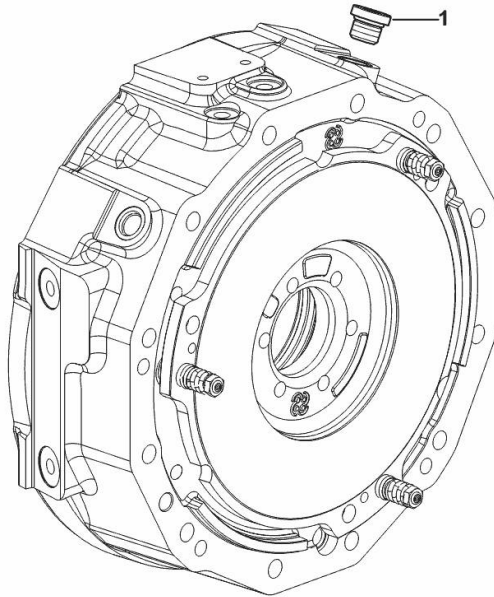

9\_L8066\_32\_0-A-001

**FRONT SUPPORT**

Fig.	P/n	QTY	Name
------	-----	-----	------

**Notes:**

- FOR TYPES WITHOUT FRONT PTO AND FRONT LIFT [XM 100 T4i HI-LEVEL]

1	0.018.9333.0/10	1	front support
2	2.0113.629.2	4	screw m 16 p.2x100
3	2.1475.206.7	8	washer 17x32
5	2.0443.426.7	4	stud bolt m 16 p.1.5x110
6	2.1012.309.7	4	nut m 16 p.1.5
7	0.019.0152.0	2	shim mm 0.1
8	0.019.0154.0	6	shim mm 0.2
9	2.2680.047.0	2	ring 17x22x23
11	0.019.0178.2	1	gasket
12	2.0112.213.2	2	screw m 8 p.1.25 x 35
13	2.1470.004.2	2	lock washer 8
14	2.3199.360.0	12	plug m 14 p.2
15	2.3199.361.0	8	plug m 18 p.2.5
16	2.1312.004.2	2	washer 8x24x2

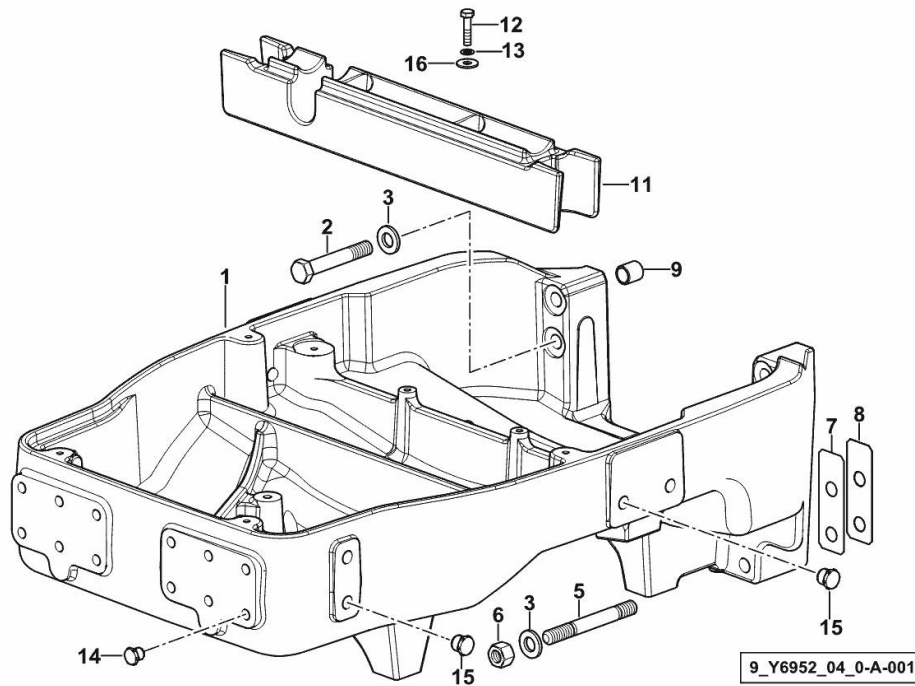



**Suggest:**

**For more complete manuals. Please go to the home page.**

**<https://www.ebooklibonline.com>**

**If the above button click is invalid. Please download this document first, and then click the above link to download the complete manual.**

**Thank you so much for reading**

**FRONT SUPPORT**

Fig.	P/n	QTY	Name
------	-----	-----	------

**Notes:**

- FOR TYPES W/ OR W/ PROVISION FOR FRONT LIFT/FRONT PTO [XM 100 T4i HI-LEVEL]

1	0.018.9315.0/20	1	front support
2	2.0113.629.2	4	screw m 16 p.2x100
3	2.1475.206.7	8	washer 17x32
5	2.0443.426.7	4	stud bolt m 16 p.1.5x110
6	2.1012.309.7	4	nut m 16 p.1.5
7	0.019.0152.0	2	shim mm 0.1
8	0.019.0154.0	6	shim mm 0.2
9	2.2680.047.0	2	ring 17x22x23
10	2.1579.820.2	4	spacer 13x25x30
11	0.018.9833.2	1	gasket
12	2.0112.213.2	2	screw m 8 p.1.25 x 35
13	2.1470.004.2	2	lock washer 8
14	2.3199.360.0	12	plug m 14 p.2
15	2.3199.361.0	8	plug m 18 p.2.5
16	2.1312.004.2	2	washer 8x24x2
17	0.020.2981.0	1	dust guard sx/lh/li
18	0.020.2982.0	1	dust guard dx/rh/re

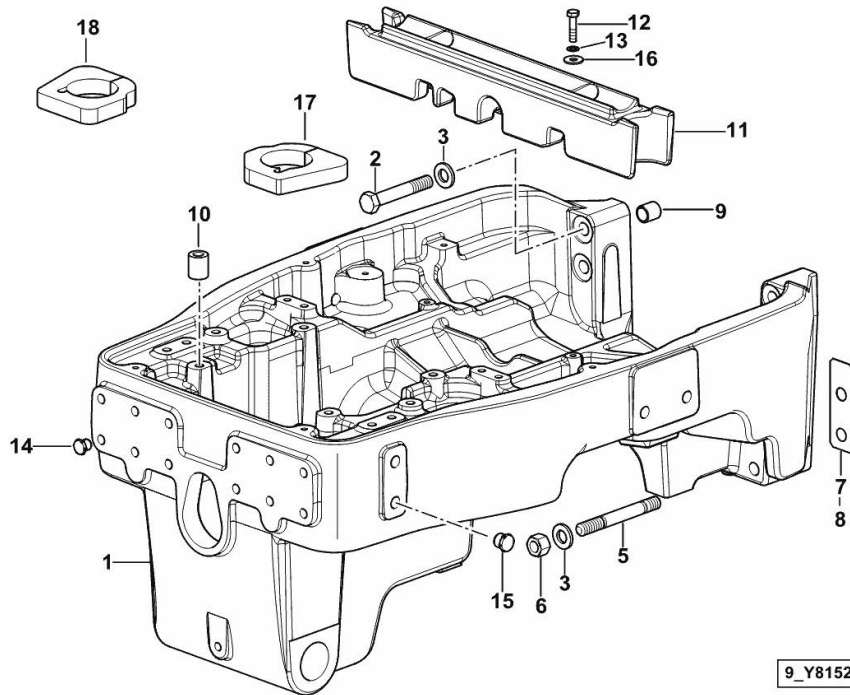

**FRONT CARRIER WITH SUSPENSION**

Fig.	P/n	QTY	Name
------	-----	-----	------

**Notes:**

- FOR TYPES W/ OR W/ PROVISION FOR FRONT LIFT/FRONT PTO [XM 100 T4i HI-LEVEL]

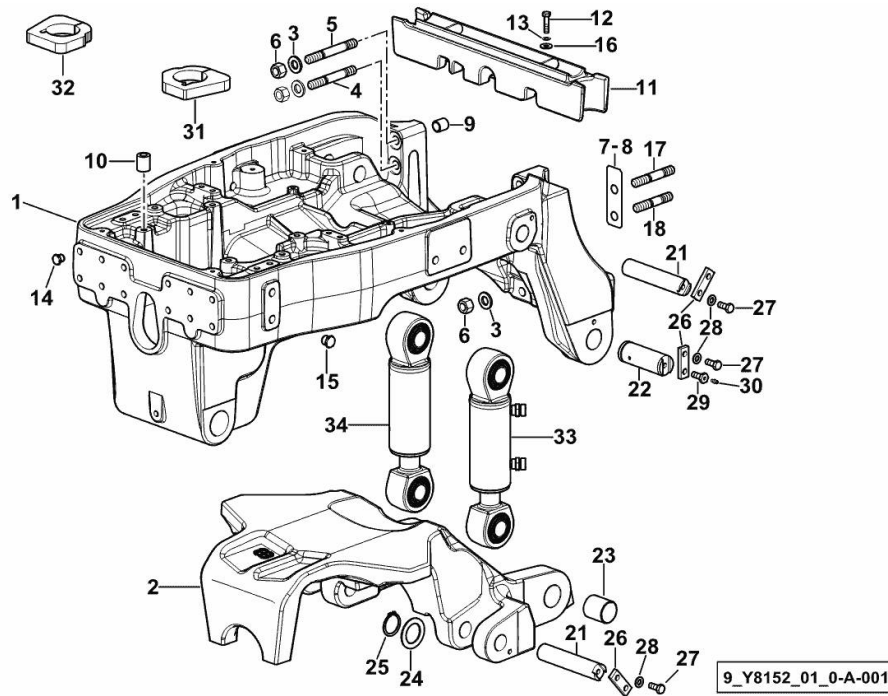

1	0.018.9317.0/20	1	front support
2	0.018.9302.0/10	1	support
3	2.1475.206.7	8	washer 17x32
4	2.0443.423.7	2	stud bolt m 16 p.1.5x90
5	2.0443.425.7	2	stud bolt m 16 p.1.5 x 100
6	2.1012.309.7	8	nut m 16 p.1.5
7	0.019.0152.0	2	shim mm 0.1
8	0.019.0154.0	6	shim mm 0.2
9	2.2680.047.0	2	ring 17x22x23
10	2.1579.820.2	4	spacer 13x25x30
11	0.018.9833.2	1	gasket
12	2.0112.213.2	2	screw m 8 p.1.25 x 35
13	2.1470.004.2	2	lock washer 8
14	2.3199.360.0	12	plug m 14 p.2
15	2.3199.361.0	8	plug m 18 p.2.5
16	2.1312.004.2	2	washer 8x24x2
17	2.0443.420.7	2	stud bolt m 16 p.1.5 x 75
18	2.0443.418.7	2	stud bolt m 16 p.1.5 x 65
21	0.015.3715.0/10	4	pin
22	04438671	2	pin
23	04424134/20	2	bushing
24	04438682	2	ring
25	2.1410.016.7	2	circlip 40x1.75
26	04422768	6	small plate
27	2.0112.309.2	10	screw m 10 p.1.5 x 25
28	2.1310.006.2	10	flat washer 10.5x21
29	04450386/20	2	screw m 10 x 25
30	2.3820.101.2	2	grease gun m 6 p.1 x 5
31	0.020.2981.0	1	dust guard sx/lh/li
32	0.020.2982.0	1	dust guard dx/rh/re
33	2.3749.015.0	1	jack sx/lh/li - Ognibene ☞ 2.3749.015.0
34	2.3749.016.0	1	jack dx/rh/re - Ognibene ☞ 2.3749.016.0

**<https://www.ebooklibonline.com>**

Hello dear friend!

Thank you very much for reading.

Enter the link into your browser.

The full manual is available for immediate download.

**<https://www.ebooklibonline.com>**