

Section: B0 - ENGINE

CRANKCASE

| Fig. | P/n | QTY | Name |
|------|-----|-----|------|
|------|-----|-----|------|

Notes:

[XF-75 -> 6001]

| | | | |
|------------|-----------------|----|------------------------------|
| 3 | 2.3199.312.2/20 | 1 | plug m 35x1.5x9.5 |
| 5 | 2.0439.273.7 | 8 | stud bolt m 8 |
| 6 | 2.1559.188.2 | 4 | bush 11.4 x 14 x16 |
| 7 | 2.1539.259.0 | 8 | special oil seal 107.62x2.62 |
| 8 | 2.1560.010.0 | 1 | gasket 14.2 x 20 |
| 9 | 2.3199.292.0 | 1 | plug 1/4" gas |
| 11 | 0.066.1152.0/10 | 4 | gasket |
| 13 | 2.1549.154.2 | 4 | bush 4.8x5.8x16 |
| 14 | 0.015.2988.4/10 | 1 | crankcase |
| 14.1 | 2.3130.001.1 | 10 | plug 1/8" gas |
| 14.2 | 2.3130.002.1 | 2 | plug 1/4" gas |
| 14.3 | 2.3130.003.1 | 6 | plug 3/8" gas |
| 14.4.1.1.1 | 0.065.1112.7/10 | 1 | support |
| 14.4.1.2 | 2.1699.165.0 | 1 | bush 12.3x15x16 |
| 14.4.2 | 0.065.1114.0/10 | 3 | support |
| 14.4.3 | 0.065.1116.3 | 1 | support |
| 14.4.3.2 | 2.1699.165.0 | 1 | bush 12.3x15x16 |
| 14.4.5 | 0.065.1117.0 | 10 | screw m 12 x 100 |
| 14.5 | 2.3179.012.0 | 1 | plug 60 |
| 14.6 | 0.065.1140.0 | 4 | special bushing 59X55X20 |
| 14.7 | 0.065.1141.0 | 1 | special bushing 59X55X30 |
| 14.8 | 0.014.1340.0/10 | 1 | pin mm 85 |
| 25 | 0.013.4946.0/10 | 1 | sprayer nozzle |
| 26 | 2.3120.101.0 | 1 | plug m 18 p.1.5 |
| 28 | 2.1560.014.0 | 1 | washer 18.2 x 24 |

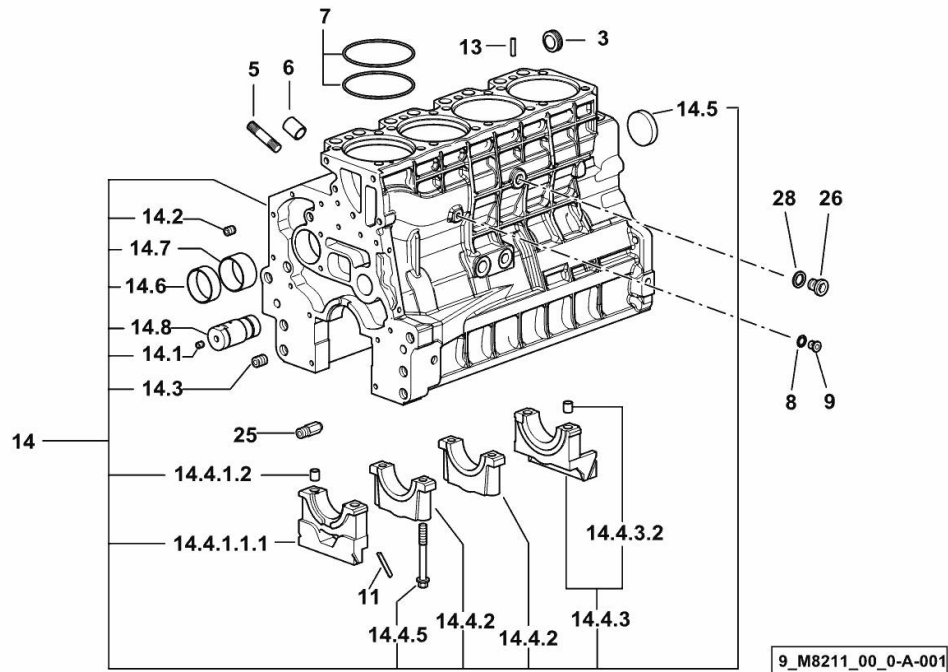

Section: B0 - ENGINE

CRANKCASE

| Fig. | P/n | QTY | Name |
|------|-----|-----|------|
|------|-----|-----|------|

Notes:

- EXPORT U.S.A. [XF-75 -> 6001]



9_O1011_00_0-A-001

| | | | |
|------------|-----------------|----|------------------------------|
| 3 | 2.3199.312.2/20 | 1 | plug m 35x1.5x9.5 |
| 5 | 2.0439.279.7 | 8 | stud bolt m 8 p.1 x 25 |
| 6 | 2.1559.188.2 | 4 | bush 11.4 x 14 x16 |
| 7 | 2.1539.259.0 | 8 | special oil seal 107.62x2.62 |
| 8 | 2.1560.010.0 | 1 | gasket 14.2 x 20 |
| 9 | 2.3199.292.0 | 1 | plug 1/4" gas |
| 10 | 0.014.9655.4/30 | 1 | crankcase |
| 10.1 | 2.3130.001.1 | 14 | plug 1/8" gas |
| 10.2 | 2.3130.002.1 | 4 | plug 1/4" gas |
| 10.3 | 2.3130.003.1 | 6 | plug 3/8" gas |
| 10.4.1.1.1 | 0.065.1112.7/10 | 1 | support |
| 10.4.1.2 | 2.1699.165.0 | 1 | bush 12.3x15x16 |
| 10.4.2 | 0.065.1114.0/10 | 3 | support |
| 10.4.3 | 0.065.1116.3 | 1 | support |
| 10.4.3.2 | 2.1699.165.0 | 1 | bush 12.3x15x16 |
| 10.4.8 | 0.065.1117.0 | 10 | screw m 12 x 100 |
| 10.5 | 2.3179.012.0 | 1 | plug 60 |
| 10.6 | 0.065.1140.0 | 4 | special bushing 59X55X20 |
| 10.7 | 0.065.1141.0 | 1 | special bushing 59X55X30 |
| 10.8 | 0.014.1340.0/10 | 1 | pin mm 85 |
| 11 | 0.066.1152.0/10 | 4 | gasket |
| 13 | 2.1549.154.2 | 4 | bush 4.8x5.8x16 |
| 25 | 0.013.4946.0/10 | 1 | sprayer nozzle |
| 26 | 2.3120.101.0 | 1 | plug m 18 p.1.5 |
| 28 | 2.1560.014.0 | 1 | washer 18.2 x 24 |

Section: B0 - ENGINE

MONOBLOC ENGINE-GEARBOX CONNECTING FLANGE

| Fig. | P/n | QTY | Name |
|------|-----|-----|------|
|------|-----|-----|------|

Notes:

[XF-75 -> 6001]

| | | | |
|---|-----------------|---|-----------------------------------|
| 1 | 0.007.7752.0/30 | 1 | flange |
| 2 | 2.0112.511.2 | 8 | screw m 14 p.2 x 30 |
| 3 | 2.1651.912.0 | 2 | cylindrical plug 12x28 |
| 4 | 2.1651.917.0 | 1 | cylindrical plug 12x40 |
| 5 | 2.0432.257.7 | 1 | stud bolt m 12 p.1.75 - 1.25 x 30 |
| 6 | 2.0439.250.7 | 1 | stud bolt m 12 / m 10 x 30 |
| 7 | 0.011.9294.0/10 | 1 | bush |

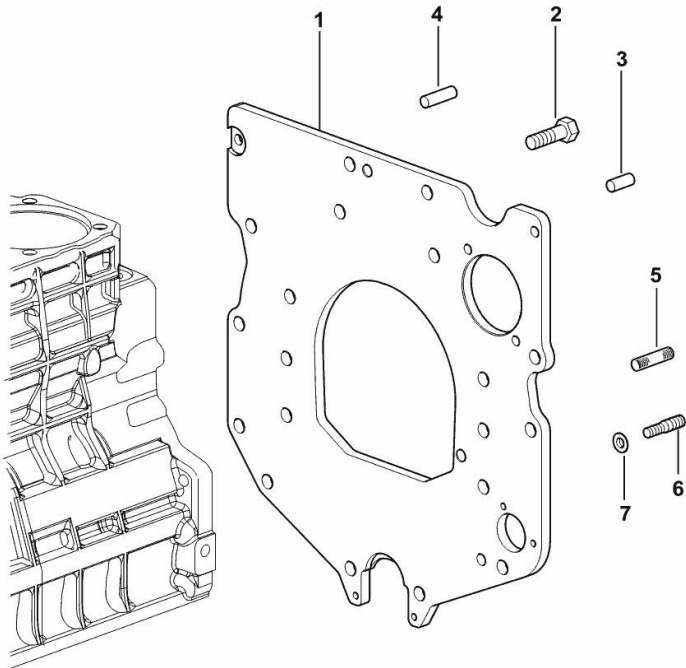

9_37311_01_0-A-001

<https://www.ebooklibonline.com>

Hello dear friend!

Thank you very much for reading.

Enter the link into your browser.

The full manual is available for immediate download.

<https://www.ebooklibonline.com>

SIDE PLUG FOR CYLINDER BLOCK

| Fig. | P/n | QTY | Name |
|------|-----|-----|------|
|------|-----|-----|------|

Notes:

[XF-75 -> 6001]

| | | | |
|----|--------------|---|------------------|
| 22 | 2.1560.017.0 | 1 | gasket 22.2 x 27 |
| 23 | 2.3120.002.4 | 1 | plug m 22 x 1.5 |

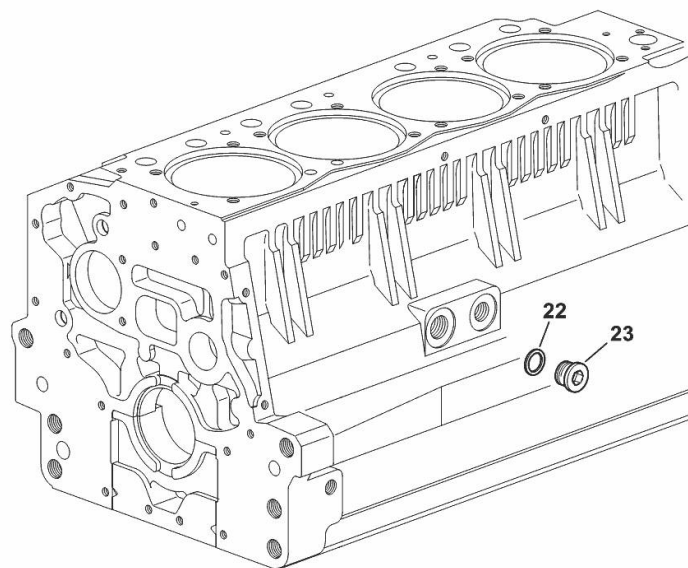

9_33211_07_0-A-001

FITTING FOR ENGINE OIL PRESSURE SWITCH

| Fig. | P/n | QTY | Name |
|------|-----|-----|------|
|------|-----|-----|------|

Notes:

[XF-75 -> 6001]

| | | | |
|---|--------------|---|-------------------------|
| 1 | 2.3249.014.2 | 1 | pipe fitting m 12 p.1.5 |
| 2 | 2.1560.008.0 | 3 | gasket 12.2 x 18 |
| 3 | 2.3335.052.2 | 1 | pipe union m 12 p.1.5 |

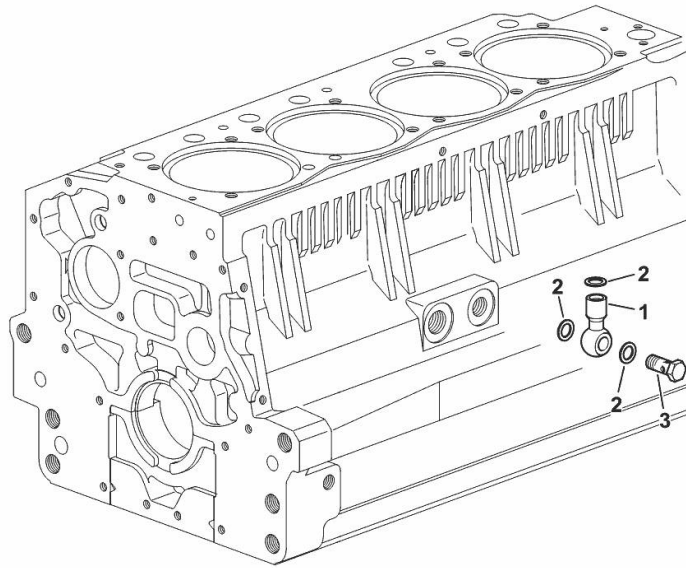

9_32315_07_0-A-001

PLUG

| Fig. | P/n | QTY | Name |
|------|-----|-----|------|
|------|-----|-----|------|

Notes:
[XF-75 -> 6001]

| | | | |
|---|--------------|---|---------------|
| 1 | 2.3130.003.1 | 1 | plug 3/8" gas |
|---|--------------|---|---------------|

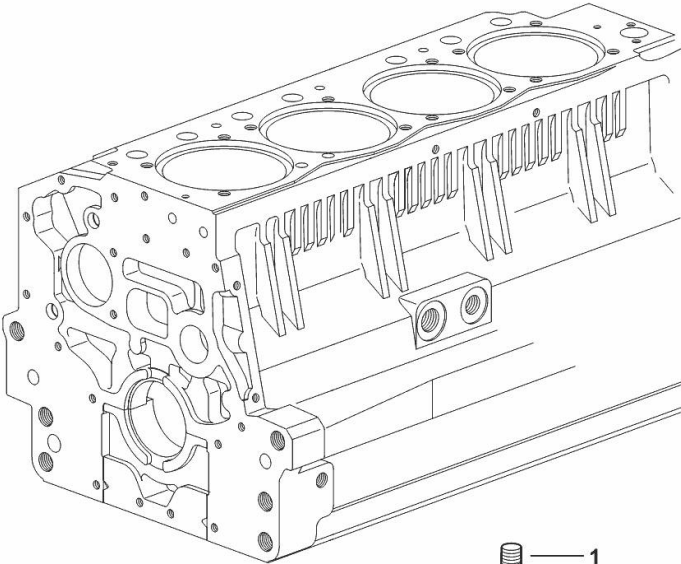

1

9_34311_06_0-A-001

FITTING FOR ENGINE OIL PRESSURE SWITCH

| Fig. | P/n | QTY | Name |
|------|-----|-----|------|
|------|-----|-----|------|

Notes:

[XF-75 -> 6001]

| | | | |
|-----|-----------------|---|--------------------------------|
| 100 | 2.3339.353.2/20 | 1 | pipe fitting 12 p.1.5-18 p.1.5 |
| 101 | 2.1560.014.0 | 1 | washer 18.2 x 24 |

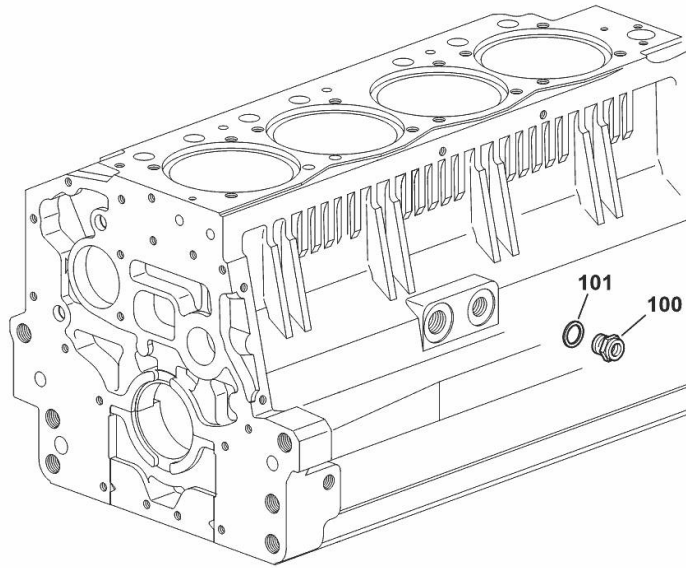

9_33215_12_0-A-001

Section: B0 - ENGINE

CRANKSHAFT PULLEY

| Fig. | P/n | QTY | Name |
|------|-----|-----|------|
|------|-----|-----|------|

Notes:

[XF-75 -> 6001]

| | | | |
|---|-----------------|---|-------------------------|
| 1 | 0.013.6349.0/10 | 1 | pulley |
| 2 | 0.011.3515.0/20 | 1 | hub Z = 48 |
| 3 | 0.065.1256.0 | 2 | ring 45x52 |
| 4 | 2.1579.865.0 | 1 | spacer 45.2x51.8x10 |
| 5 | 2.0439.195.7 | 1 | stud bolt m 20 p.1.5x80 |
| 6 | 2.1019.094.7 | 1 | nut m 20 p.1.5 |
| 7 | 2.0112.320.2 | 6 | screw m 10 p.1.5 x 55 |
| 8 | 2.1470.006.2 | 6 | lock washer 10 |

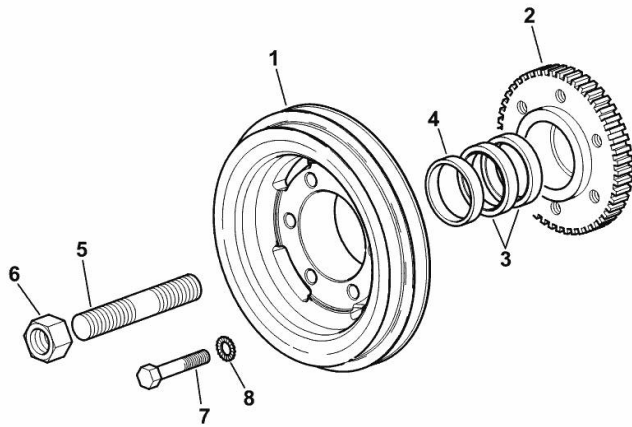

9_N1412_03_0-A-001

COOLANT PUMP AND ALTERNATOR DRIVEBELT

| Fig. | P/n | QTY | Name |
|------|-----|-----|------|
|------|-----|-----|------|

Notes:

[XF-75 -> 6001]

| | | | |
|---|--------------|---|----------------------|
| 1 | 2.4119.177.0 | 1 | belt AV 12.7x1285 mm |
|---|--------------|---|----------------------|

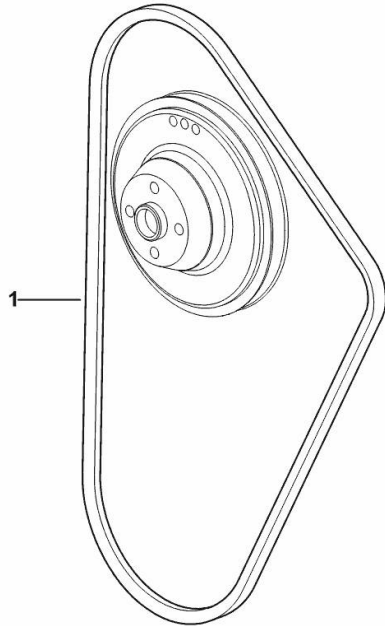

9_N4817_02_0-A-001

COOLANT PUMP AND ALTERNATOR DRIVEBELT

| Fig. | P/n | QTY | Name |
|------|-----|-----|------|
|------|-----|-----|------|

Notes:

- FOR MODELS WITH COMPRESSOR [XF-75 -> 6001] 6014 <-

| | | | |
|---|-----------------|---|----------------------|
| 1 | 2.4119.149.0/10 | 1 | belt AV 13x1262 mm |
| 2 | 2.4119.143.0 | 1 | belt AV 12.7x1225 mm |

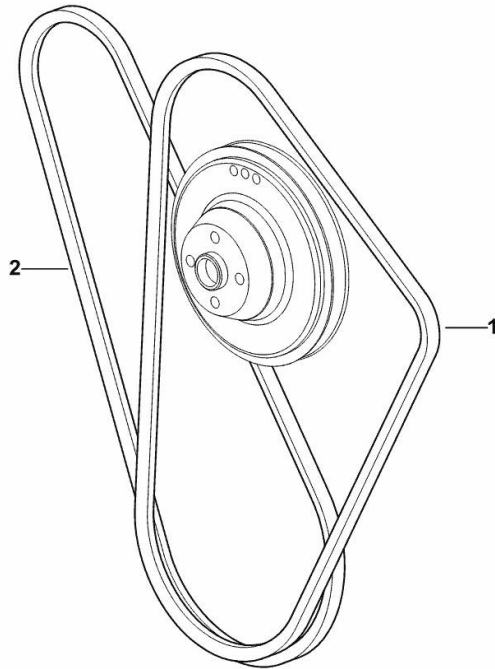

9_N1417_04_0-A-001

COOLANT PUMP AND ALTERNATOR DRIVEBELT

| Fig. | P/n | QTY | Name |
|------|-----|-----|------|
|------|-----|-----|------|

Notes:

- FOR MODELS WITH COMPRESSOR [XF-75 -> 6001] -> 6016

| | | | |
|---|--------------|---|----------------------|
| 1 | 2.4119.177.0 | 1 | belt AV 12.7x1285 mm |
| 2 | 2.4119.143.0 | 1 | belt AV 12.7x1225 mm |

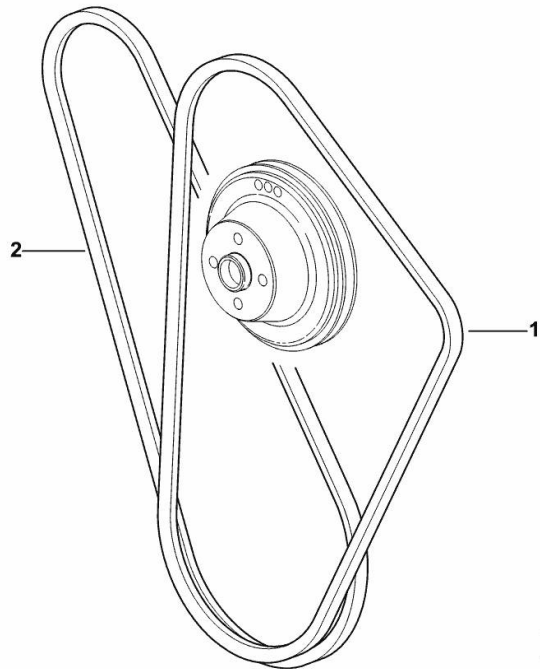

9_N4917_04_0-A-001

Section: B0 - ENGINE

CRANKSHAFT

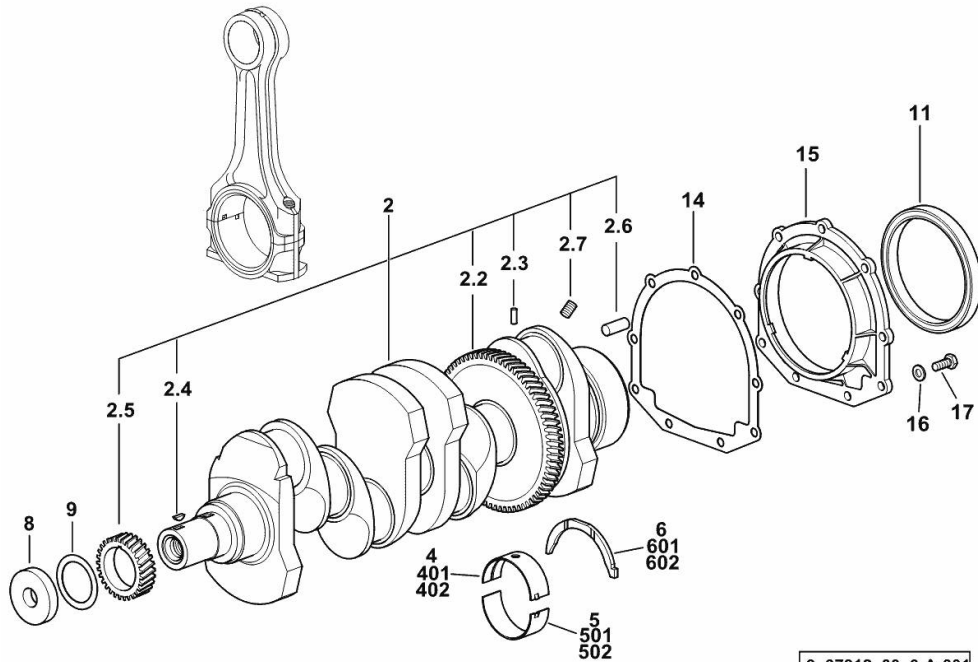

9_37312_00_0-A-001

| Fig. | P/n | QTY | Name |
|------|-----|-----|------|
|------|-----|-----|------|

Notes:

[XF-75 -> 6001]

| | | | |
|-----|-----------------|---|-----------------------------|
| 2 | 0.086.1210.3/40 | 1 | crankshaft |
| 2.2 | 0.065.1211.0/10 | 1 | crown wheel |
| 2.3 | 2.1630.608.0 | 1 | pin 6x16 |
| 2.4 | 2.1720.006.0 | 1 | key 4x6.5 |
| 2.5 | 0.065.1323.0/30 | 1 | gear Z = 29 |
| 2.6 | 2.1651.915.0 | 1 | pin 12x35 |
| 2.7 | 2.3130.001.1 | 4 | plug 1/8" gas |
| 4 | 0.065.1215.0/10 | 5 | main half bushing STANDARD |
| 5 | 0.065.1216.0/10 | 5 | main half bushing STANDARD |
| 6 | 0.065.1218.0 | 4 | shim STANDARD |
| 8 | 2.1599.524.7 | 1 | washer 21x60x12 |
| 9 | 2.1589.189.0 | 2 | shoulder ring mm 1.00 |
| 11 | 2.1529.073.0 | 1 | special oil seal 110x130x13 |
| 14 | 0.065.1254.0/20 | 1 | gasket |
| 15 | 0.007.1711.0/10 | 1 | cover |
| 16 | 2.1475.002.2 | 9 | conical washer 8 |
| 17 | 2.0112.207.2 | 9 | screw m 8 p 1.25 x 20 |
| 401 | 0.065.1215.7 | | main half bushing - mm 0.25 |
| 402 | 0.065.1215.8 | | main half bushing - mm 0.50 |
| 501 | 0.065.1216.7 | | main half bushing - mm 0.25 |
| 502 | 0.065.1216.8 | | main half bushing - mm 0.50 |
| 601 | 0.065.1218.7 | | shim + mm 0.10 |
| 602 | 0.065.1218.8 | | shim + mm 0.15 |

Section: B0 - ENGINE
ENGINE FLYWHEEL

| Fig. | P/n | QTY | Name |
|------|-----|-----|------|
|------|-----|-----|------|

Notes:
 [XF-75 -> 6001]

| | | | |
|------|-----------------|---|----------------------|
| 50 | 0.255.2525.0/10 | 1 | flange |
| 51 | 0.076.1247.3/30 | 1 | flywheel |
| 51.2 | 0.065.1242.0 | 1 | crown wheel Z = 123 |
| 52 | 2.0139.022.2 | 6 | screw m 12 p.1.25x55 |

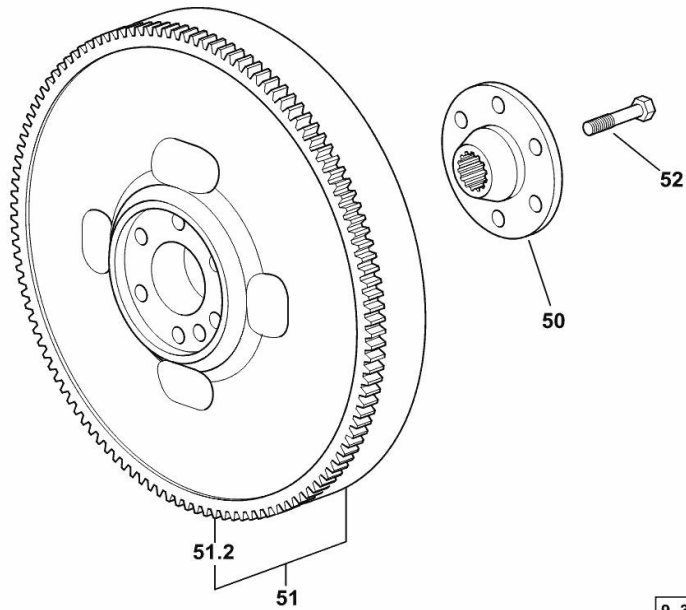

9_33212_07_0-A-001



Suggest:

For more complete manuals. Please go to the home page.

<https://www.ebooklibonline.com>

If the above button click is invalid. Please download this document first, and then click the above link to download the complete manual.

Thank you so much for reading

Section: B0 - ENGINE
COUNTERWEIGHTS

| Fig. | P/n | QTY | Name |
|------|-----|-----|------|
|------|-----|-----|------|

Notes:
 [XF-75 -> 6001]

| | | | |
|-----------|-----------------|---|---------------------------|
| 25 | 2.1589.139.0 | 1 | shoulder ring mm 0.3 |
| 26 | 2.1589.140.0 | 3 | shoulder ring mm 0.1 |
| 29 | 2.1579.628.0 | 3 | spacer 16.5x26x0.1 |
| 33 | 2.1579.629.0 | 6 | spacer 12.5x26x0.1 |
| 34 | 2.1589.048.0 | 1 | shoulder ring 16.5x26x0.3 |
| 35 | 2.1589.049.0 | 1 | shoulder ring 12.5x26x0.3 |
| 38.1.1 | 0.086.1231.0/10 | 1 | box |
| 38.1.2 | 2.3130.001.1 | 4 | plug 1/8" gas |
| 38.2 | 0.086.1233.3/30 | 1 | mass sx/lh/li |
| 38.2.2 | 2.1559.115.0 | 2 | special bushing 26x30x30 |
| 38.2.99.4 | 2.1651.302.0 | 1 | roll pin 4x6 |
| 38.3 | 0.065.1233.3/30 | 1 | mass dx/rh/re |
| 38.3.2 | 2.1559.115.0 | 2 | special bushing 26x30x30 |
| 38.3.99.4 | 2.1651.302.0 | 1 | roll pin 4x6 |
| 38.3.99.5 | 2.1410.018.7 | 1 | circlip 45 |
| 38.4.1 | 0.065.1234.0/10 | 1 | shaft |
| 38.4.2 | 2.3130.001.1 | 1 | plug 1/8" gas |
| 38.5 | 2.1631.717.0 | 2 | roll pin 8 x 40 |
| 38.6 | 2.1589.185.0 | 4 | shoulder ring 26.1x34x1 |
| 38.7 | 2.0522.212.7 | 1 | screw m 8 p.1.25 x 30 |
| 44 | 2.1579.626.0 | 2 | spacer 13.2x16x11 |
| 45 | 2.0139.028.2 | 4 | screw m 12 |
| 46 | 2.1699.191.0 | 1 | bush 7x10x16 |

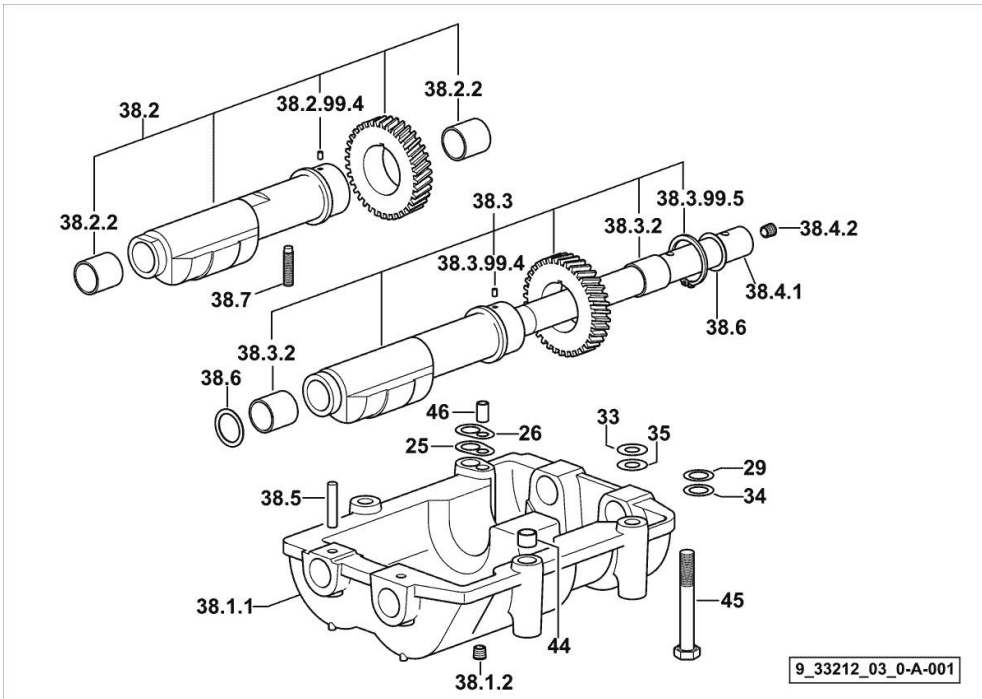

CYLINDER - PISTON - CONNECTING ROD

| Fig. | P/n | QTY | Name |
|------|-----|-----|------|
|------|-----|-----|------|

Notes:

[XF-75 -> 6001]

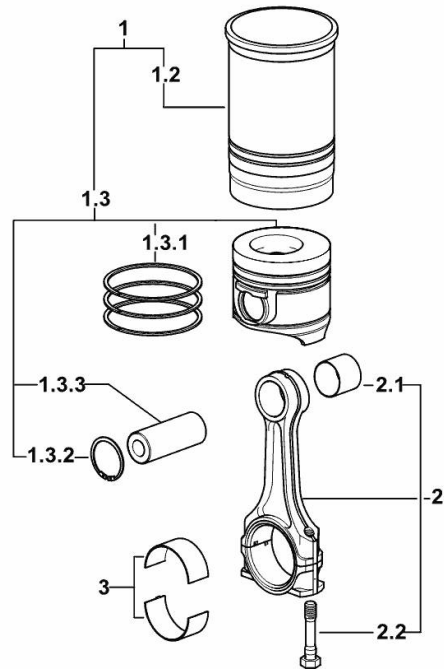

| | | | |
|-------|-----------------|---|--|
| 1 | 0.082.0065.A | 4 | cyl. piston assembly "A" - CLASS A |
| 1 | 0.082.0065.B | 4 | cyl. piston assembly "B" - CLASS B |
| 1.2 | 0.A12.2675.0 | 1 | engine cylinder "A" - CLASS A |
| 1.2 | 0.B12.2675.0 | 1 | engine cylinder "B" - CLASS B |
| 1.3 | 0.082.0060.A | 1 | complete piston "A" - CLASS A |
| 1.3 | 0.082.0060.B | 1 | complete piston "B" - CLASS B |
| 1.3.1 | 0.086.0052.6/10 | 1 | piston ring set |
| 1.3.2 | 2.1411.014.1 | 2 | circlip 35 |
| 1.3.3 | 0.078.1236.0 | 1 | piston pin Ø 18 / Ø 35 / L = mm 86 |
| 2 | 0.078.1220.3/30 | 4 | engine connecting rod |
| 2.1 | 2.1559.114.0/10 | 1 | special bushing |
| 2.2 | 2.0399.213.0 | 2 | screw m 12 p.1.25x61.5 |
| 3 | 0.065.1225.0 | 8 | con.rod half bushing STANDARD - A = 28.75 -> 29.00 |
| 3 | 0.065.1225.7 | 8 | con.rod half bushing - mm 0.25 |
| 3 | 0.065.1225.8 | 8 | con.rod half bushing - mm 0.50 |

9_M8212_01_M-A-001

<https://www.ebooklibonline.com>

Hello dear friend!

Thank you very much for reading.

Enter the link into your browser.

The full manual is available for immediate download.

<https://www.ebooklibonline.com>