

LIGHT ENGINE 75 kW

Fig.	P/n	QTY	Name
-------------	------------	------------	-------------

Notes:

- NOT FOR EUROPEAN MARKET [XB 105.4 T4i -> ZKDCG90200TH20001]

1	I6.K8005.00.0	-	engine 75 kW ON ORDERING PLEASE ENGINE NO. REQUIRED
---	---------------	---	---

9_MOT4CYL_00_0

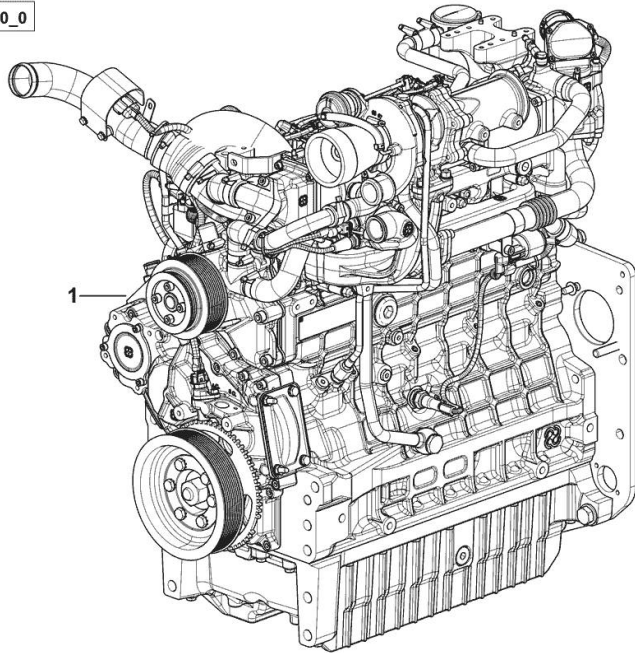

CRANKCASE

Fig.	P/n	QTY	Name
------	-----	-----	------

Notes:

[XB 105.4 T4i -> ZKDCG90200TH20001]

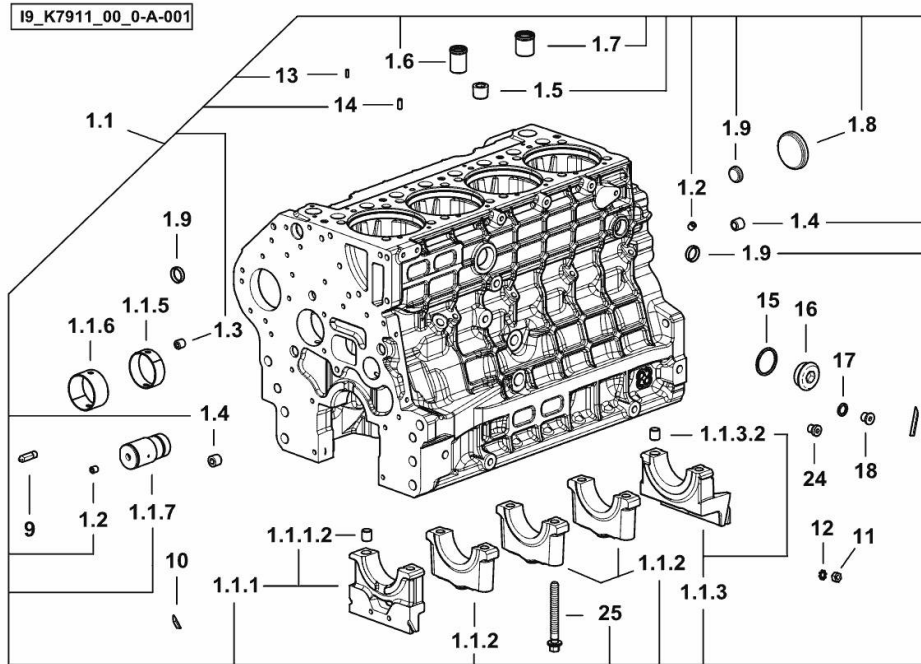

1.1	0.020.4332.3/20	1	crankcase
1.1.1	0.019.5106.3	1	support
1.1.1.2	2.1699.165.0	1	bush 12.3x15x16
1.1.2	0.019.5107.7	3	support
1.1.3	0.019.5108.3	1	support
1.1.3.2	2.1699.165.0	1	bush 12.3x15x16
1.1.5	0.065.1140.0	4	special bushing 59X55X20
1.1.6	0.065.1141.0	1	special bushing 59X55X30
1.1.7	0.019.4412.0	1	pin
1.2	2.3130.001.7	15	plug
1.3	2.3130.002.7	2	plug 1/4" gas
1.4	2.3130.003.7	4	plug 3/8" gas
1.5	2.3130.005.7	3	plug
1.6	0.019.4146.0	1	tube
1.7	0.019.6173.0	1	tube
1.8	2.3179.012.0	1	plug 60
1.9	2.3171.010.4	5	plug 25
9	0.019.4415.0/10	1	tube
10	0.066.1152.0/10	4	gasket
11	2.1011.405.2	2	nut m 8 p.1
12	2.1470.004.2	4	lock washer 8
13	2.1651.305.0	4	pin 4 x 12
14	2.1651.507.0	4	pin 6 x 16
15	2.1560.027.0	1	copper gasket 38.3x44
16	2.3139.031.2	1	plug
17	2.1560.010.0	1	gasket 14.2 x 20
18	2.3199.292.0	1	plug 1/4" gas
24	2.3139.024.2	1	plug m 12 p.1.5 (-> 20001)
25	2.0399.367.7	10	screw

CYLINDER LINER O-RING

Fig.	P/n	QTY	Name
------	-----	-----	------

Notes:

[XB 105.4 T4i -> ZKDCG90200TH20001]

16	2.1539.259.0	8	special oil seal 107.62x2.62
----	--------------	---	------------------------------

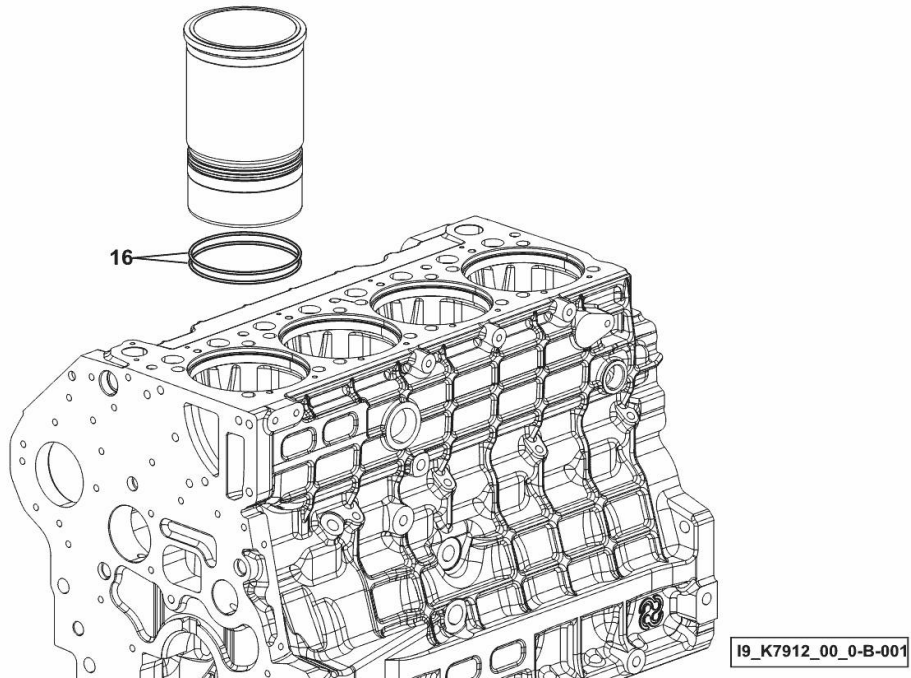

<https://www.ebooklibonline.com>

Hello dear friend!

Thank you very much for reading.

Enter the link into your browser.

The full manual is available for immediate download.

<https://www.ebooklibonline.com>

SIDE PLUG FOR CYLINDER BLOCK

Fig.	P/n	QTY	Name
------	-----	-----	------

Notes:

- FOR TYPES WITH TRAILER AIR BRAKING [XB 105.4 T4i -> ZKDCG90200TH20001]

12	2.1560.018.0	1	gasket 22.2 x 29
13	2.3120.102.0	1	plug

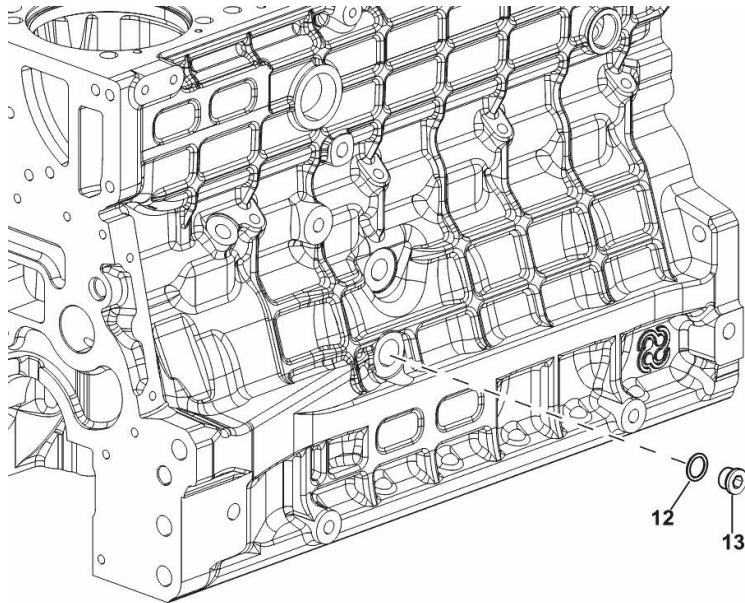

9_K8015_03_0-B-001

MONOBLOC ENGINE-GEARBOX CONNECTING FLANGE

Fig.	P/n	QTY	Name
------	-----	-----	------

Notes:

[XB 105.4 T4i -> ZKDCG90200TH20001]

1	2.1475.005.2	2	washer 14
2	2.0112.524.2	2	screw m 14 p.2 x 75
3	2.0112.624.2	2	screw m 16 p.2 x 75
4	2.1475.006.2	2	spring washer 16
6	2.0439.250.7	1	stud bolt m 12 / m 10 x 30
7	0.011.9294.0/10	1	bush
25	0.019.1488.0	1	flange
26	2.0112.511.2	8	screw m 14 p.2 x 30
27	2.1651.912.0	2	cylindrical plug 12x28
28	2.1651.917.0	1	cylindrical plug 12x40
29	2.0432.257.7	1	stud bolt m 12 p.1.75 - 1.25 x 30

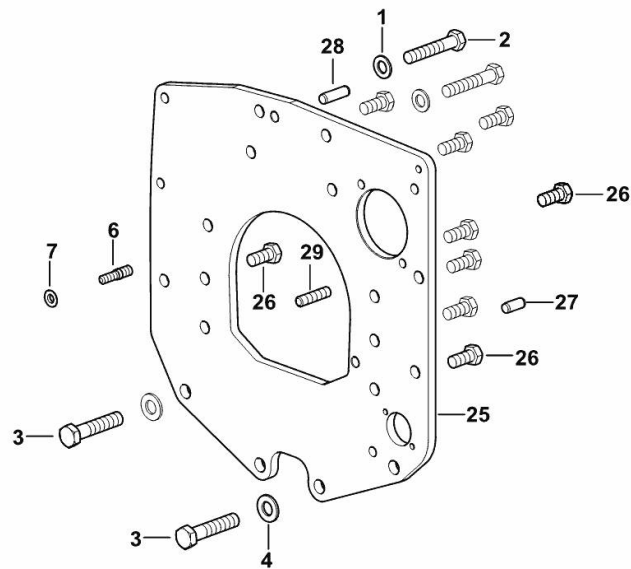

[9_K7411_01_0-A-001]

ENGINE FLYWHEEL

Fig.	P/n	QTY	Name
------	-----	-----	------

Notes:

[XB 105.4 T4i -> ZKDCG90200TH20001]

1	0.019.2098.3	1	flywheel
1.2	0.065.1242.0	1	crown wheel Z = 123
2	0.255.2525.0/10	1	flange
3	2.0399.371.0	6	screw

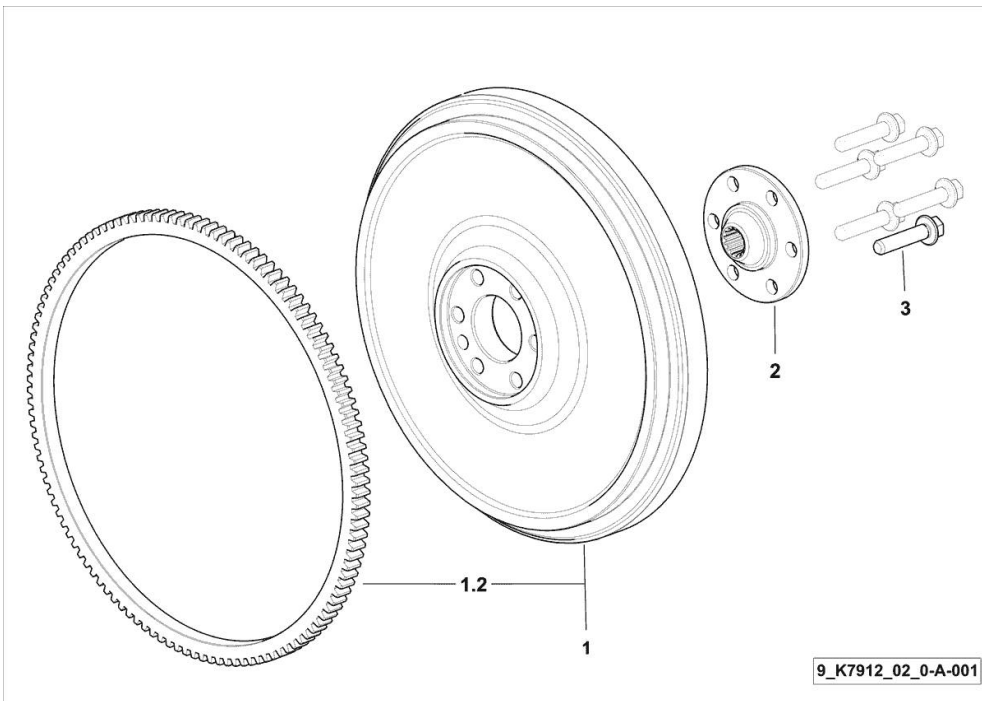

CRANKSHAFT PULLEY

Fig.	P/n	QTY	Name
------	-----	-----	------

Notes:

[XB 105.4 T4i -> ZKDCG90200TH20001]

1	0.019.9925.0	1	pulley
2	0.019.6668.0	1	flange
3	0.065.1256.0	2	ring 45x52
4	2.1579.865.0	1	spacer 45.2x51.8x10
5	2.0439.195.7	1	stud bolt m 20 p.1.5x80
6	2.1019.094.7	1	nut m 20 p.1.5
7	2.0112.320.2	6	screw m 10 p.1.5 x 55
8	2.1470.006.2	6	lock washer 10
9	2.1720.006.0	1	key 4x6.5
10	0.019.6413.0	1	gear wheel
11	2.1651.505.0	1	cylindrical plug 6x12

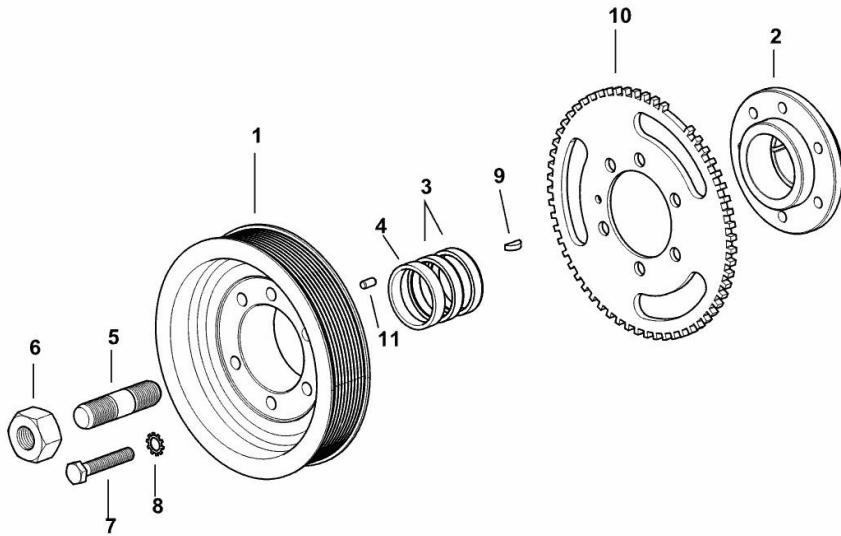

19_K7812_01_0-A-001

BELT AND TENSIONER

Fig.	P/n	QTY	Name
-------------	------------	------------	-------------

Notes:

- WITH MANUAL AIR CONDITIONING [XB 105.4 T4i -> ZKDCG90200TH20001]

1	2.4119.218.0/10	1	belt PK 10 L=2017
3	0.019.9869.4/10	3	pulley guide
4	2.0312.214.2	5	screw m 8 p.1.25 x 40
5	0.020.4604.0	1	support
7	2.0399.380.2	1	screw
8	2.0399.379.2	1	small column
9	2.1480.015.2	1	washer 10
10	2.1480.014.2	5	washer 8
11	2.1310.004.2	2	flat washer 8.4x17
13	2.0112.209.2	2	screw m 8 p 1.25 x 25

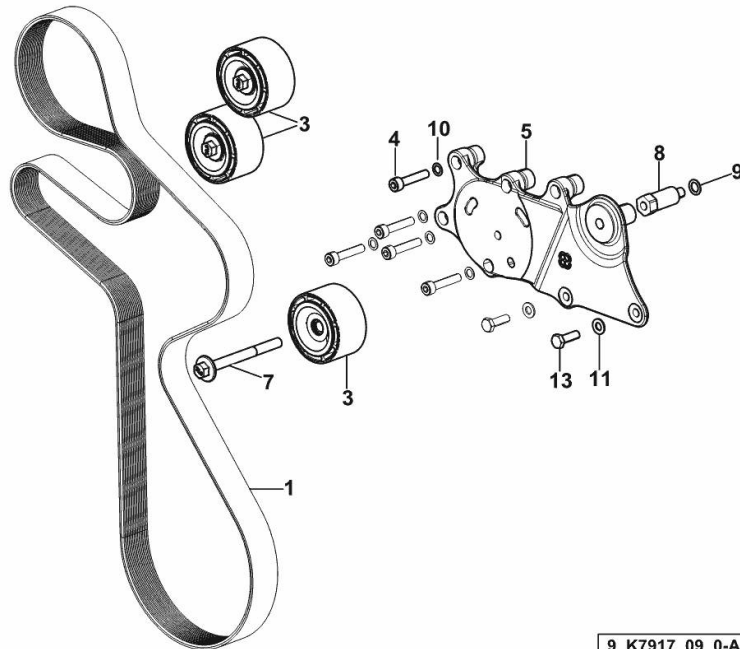

9_K7917_09_0-A-002

BELT AND TENSIONER

Fig.	P/n	QTY	Name
-------------	------------	------------	-------------

Notes:

WITHOUT AIR-CONDITIONING [XB 105.4 T4i -> ZKDCG90200TH20001]

1	2.4119.219.0	1	belt PK 10 L=1498
3	0.019.9869.4/10	2	pulley guide
4	2.0312.214.2	5	screw m 8 p.1.25 x 40
5	0.020.4604.0	1	support
7	2.0399.380.2	1	screw
8	2.0399.379.2	1	small column
9	2.1480.015.2	1	washer 10
10	2.1480.014.2	5	washer 8
11	2.1310.004.2	2	flat washer 8.4x17
13	2.0112.209.2	2	screw m 8 p 1.25 x 25

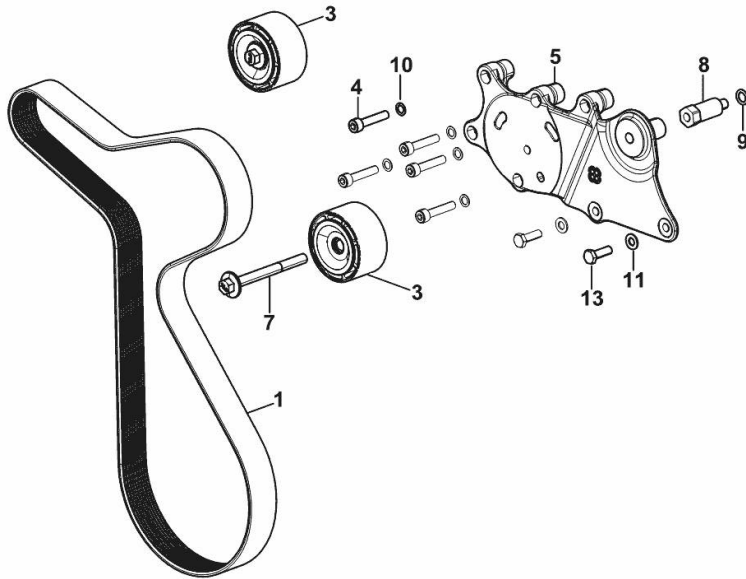

9_K7917_10_0-A-002

TENSION ROLLER

Fig.	P/n	QTY	Name
------	-----	-----	------

Notes:

[XB 105.4 T4i -> ZKDCG90200TH20001]

1	0.019.9867.4	1	tensioner
2	2.1310.006.2	1	flat washer 10.5x21
3	2.0314.322.2	1	screw

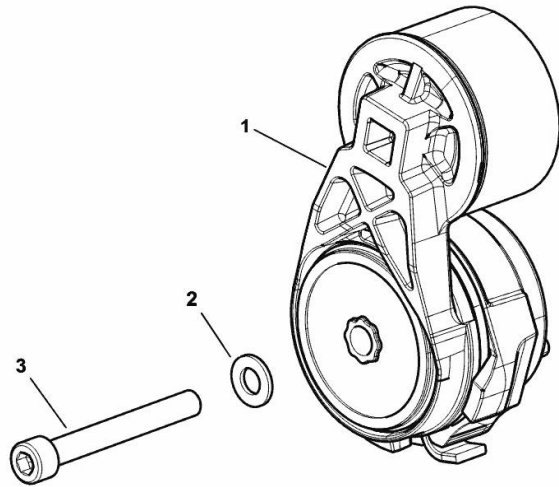

9_IB117_10_0-A-001

CRANKSHAFT

Fig.	P/n	QTY	Name
------	-----	-----	------

Notes:

[XB 105.4 T4i -> ZKDCG90200TH20001]

1	0.019.2251.3/10	1	crankshaft
1.2	0.065.1211.0/10	1	crown wheel
1.3	2.1630.608.0	1	pin 6x16
1.4	2.1651.915.0	1	pin 12x35
1.5	0.007.0855.0/10	1	gear
7	0.019.5456.0	5	main half bushing STANDARD
8	0.019.5455.0	5	main half bushing STANDARD
9	2.1599.524.7	1	washer 21x60x12
10	0.065.1218.0	4	shim STANDARD
11	2.1529.073.0	1	special oil seal 110x130x13
12	0.065.1254.0/20	1	gasket
13	0.007.0851.0/10	1	cover
14	2.1475.002.2	9	conical washer 8
15	2.0112.207.2	7	screw m 8 p 1.25 x 20
20	2.0432.003.7	2	stud bolt m 8 p.1.25 / p.1 x 20
21	2.1011.405.2	2	nut m 8 p.1
1001	0.065.1218.7		shim + mm 0.10
1002	0.065.1218.8		shim + mm 0.15

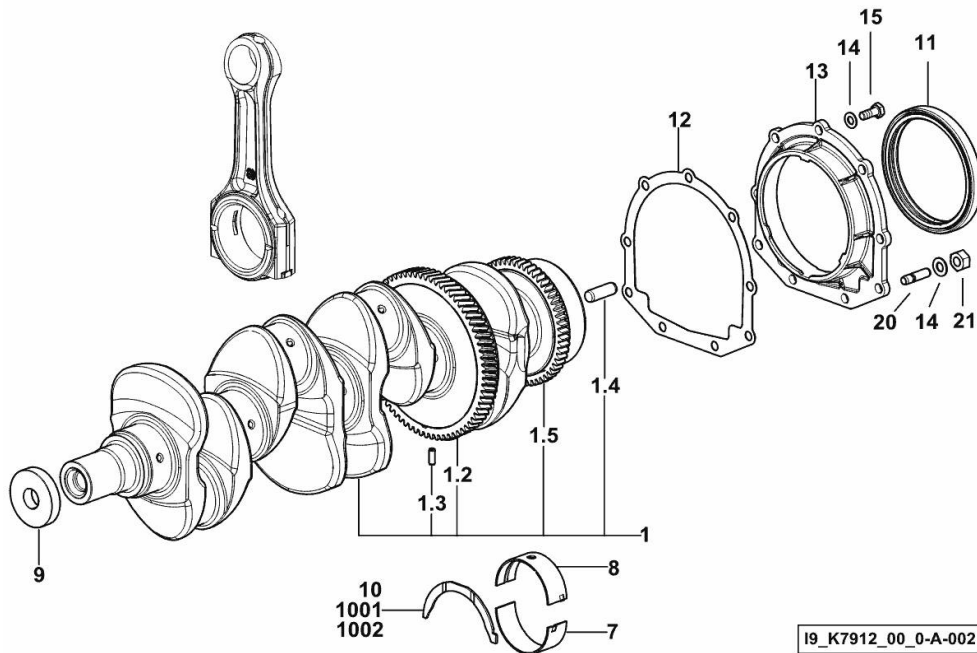

I9_K7912_00_0-A-002

CRANKSHAFT GEAR

Fig.	P/n	QTY	Name
------	-----	-----	------

Notes:

[XB 105.4 T4i -> ZKDCG90200TH20001]

1	0.019.4145.0	1	gear z = 33
2	2.1720.006.0	1	key 4x6.5

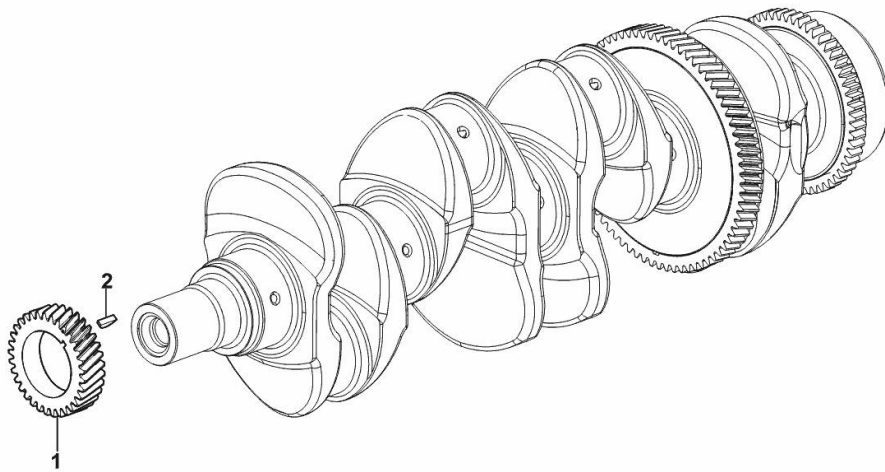

19_K7913_00_0-D-001

COUNTERWEIGHTS

Fig.	P/n	QTY	Name
------	-----	-----	------

Notes:

[XB 105.4 T4i -> ZKDCG90200TH20001]

25	2.1589.139.0	1	shoulder ring mm 0.3
26	2.1589.140.0	3	shoulder ring mm 0.1
29	2.1579.628.0	3	spacer 16.5x26x0.1
33	2.1579.629.0	6	spacer 12.5x26x0.1
34	2.1589.048.0	1	shoulder ring 16.5x26x0.3
35	2.1589.049.0	1	shoulder ring 12.5x26x0.3
38.1.1	0.086.1231.0/10	1	box
38.1.2	2.3130.001.1	4	plug 1/8" gas
38.2	0.086.1233.3/30	1	mass sx/lh/li
38.2.2	2.1559.115.0	2	special bushing 26x30x30
38.2.4	2.1651.302.0	1	roll pin 4x6
38.3	0.065.1233.3/30	1	mass dx/rh/re
38.3.2	2.1559.115.0	2	special bushing 26x30x30
38.3.4	2.1651.302.0	1	roll pin 4x6
38.3.5	2.1410.018.1	1	circlip 45
38.4.1	0.065.1234.0/10	1	shaft
38.4.2	2.3130.001.1	1	plug 1/8" gas
38.5	2.1631.717.0	2	roll pin 8 x 40
38.6	2.1589.185.0	4	shoulder ring 26.1x34x1
38.7	2.0522.212.7	1	screw m 8 p.1.25 x 30
44	2.1579.626.0	2	spacer 13.2x16x11
45	2.0139.028.2	4	screw m 12
46	2.1699.191.0	1	bush 7x10x16

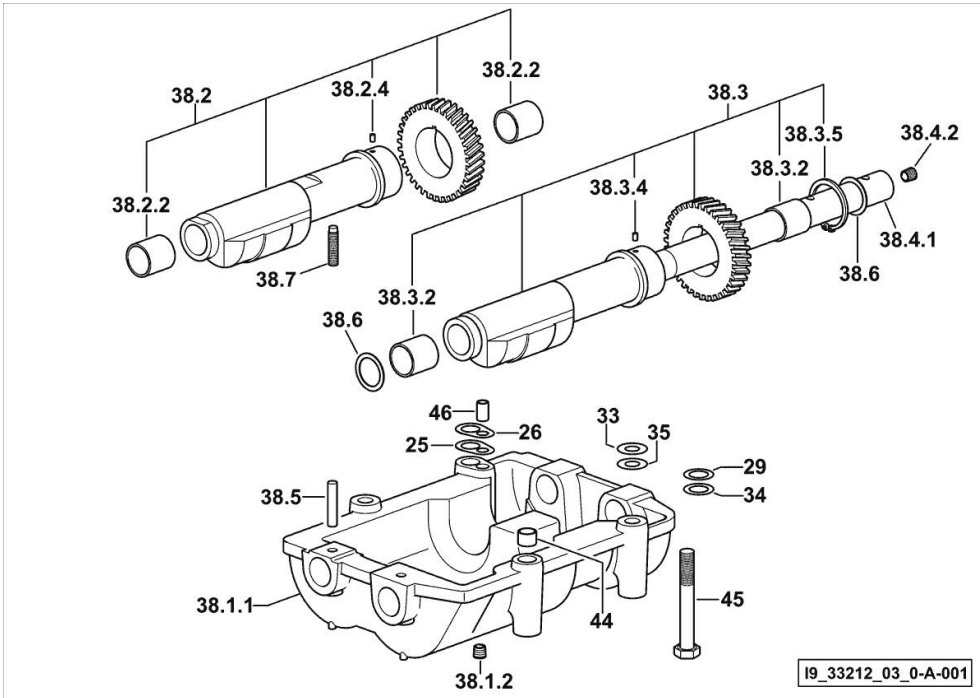

CYLINDER - PISTON - CONNECTING ROD

Fig.	P/n	QTY	Name
------	-----	-----	------

Notes:

[XB 105.4 T4i -> ZKDCG90200TH20001]

2	0.019.2226.3/10	4	engine connecting rod
2.1	2.0399.365.0	2	screw m 10 p.1.25x61.5
2.3	2.1559.532.0	1	special bushing 34.60x39.130x36.65
3	0.019.4180.0/10	4	piston
4	0.019.4717.0/30	4	engine cylinder
5	0.019.5453.0	4	con.rod half bushing STANDARD - A = 29.85 -> 30.10
6	0.019.5454.0	4	con.rod half bushing STANDARD - A = 29.85 -> 30.10
17	0.019.4187.0	4	piston pin
18	0.019.4188.0	8	circlip 35
19	0.019.4199.6	4	piston ring set
22	2.0399.365.0	8	screw m 10 p.1.25x61.5
500	0.K77.0065.6	4	cyl. piston assembly
600	0.K77.0060.6	4	complete piston

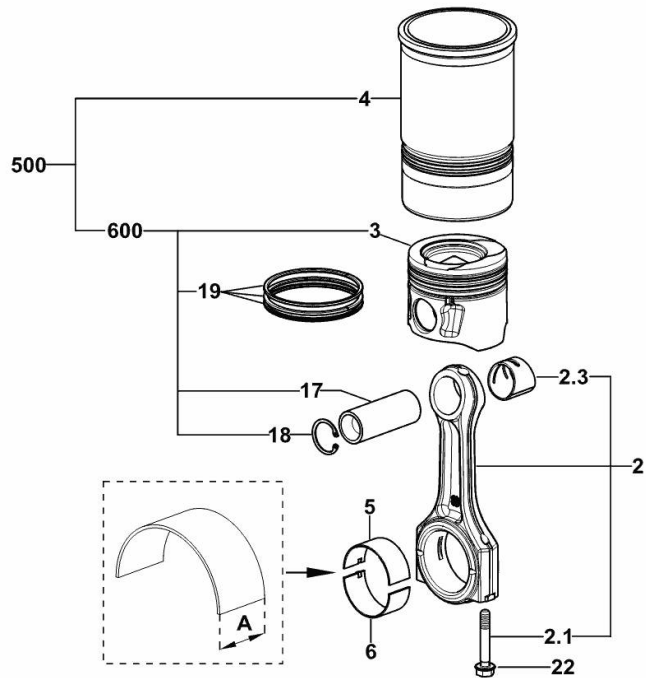

19_K7912_00_0-C-001

CAMSHAFT

Fig.	P/n	QTY	Name
------	-----	-----	------

Notes:

[XB 105.4 T4i -> ZKDCG90200TH20001]

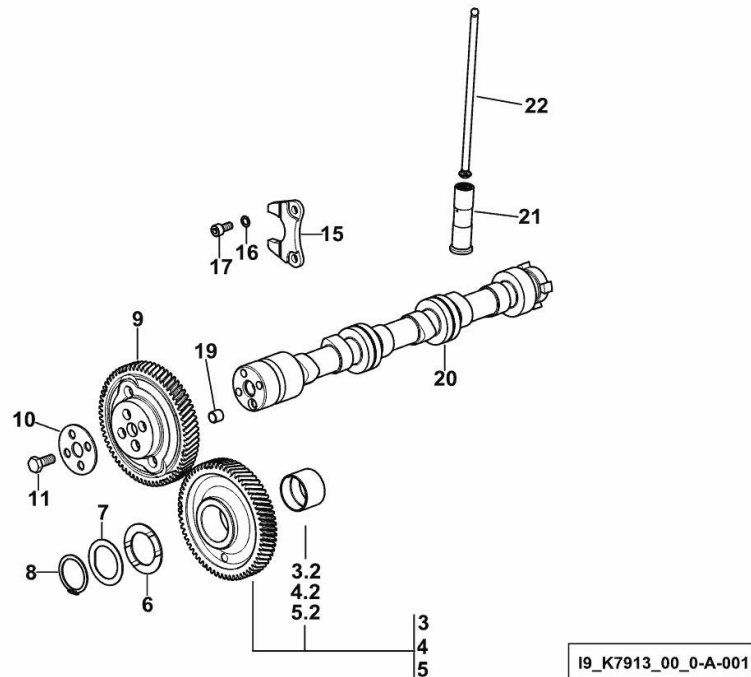

3	0.019.4874.3	0.4	gear Z=64 - WITH RED IDENTIFICATION STAMP
3.2	2.1559.185.0/10	1	bushing
4	0.019.4875.3	0.3	gear Z=64 - WITH GREEN IDENTIFICATION STAMP
4.2	2.1559.185.0/10	1	bushing
5	0.019.4876.3	0.3	gear Z=64 - WITH YELLOW IDENTIFICATION STAMP
5.2	2.1559.185.0/10	1	bushing
6	0.018.2233.0	2	shoulder ring
7	0.065.1352.0	1	shim
8	2.1410.016.1	1	circlip 40
9	0.019.4147.0	1	gear z=66
10	0.065.1350.0	1	small disc
11	2.0132.207.2	4	screw m 10 p.1 x 25
15	0.065.1353.0	1	small plate
16	2.1480.014.1	2	washer 8
17	2.0312.205.2	2	screw
19	2.1559.398.0	1	bushing 10.5x13x12
20	0.019.2505.0/10	1	camshaft
21	0.019.5378.3	8	tappets
22	0.019.1069.2	8	rod



Suggest:

For more complete manuals. Please go to the home page.

<https://www.ebooklibonline.com>

If the above button click is invalid. Please download this document first, and then click the above link to download the complete manual.

Thank you so much for reading

TIMING CASE

Fig.	P/n	QTY	Name
------	-----	-----	------

Notes:

[XB 105.4 T4i -> ZKDCG90200TH20001]

2	0.019.2123.0/10	1	gasket
3	0.019.2122.0/20	1	cover
4	2.1480.014.2	17	washer 8
6	2.0312.214.2	9	screw m 8 p.1.25 x 40
7	2.0312.208.2	8	screw m 8 p.1.25 x 25
8	2.1529.167.0	1	oil seal
19	0.020.0875.0	1	cover
20	2.1539.097.0	1	special oil seal 75.87 x 2.62
21	2.1480.012.2	3	washer 6, d128
22	2.0312.102.2	3	screw m 6 p.1 x 12

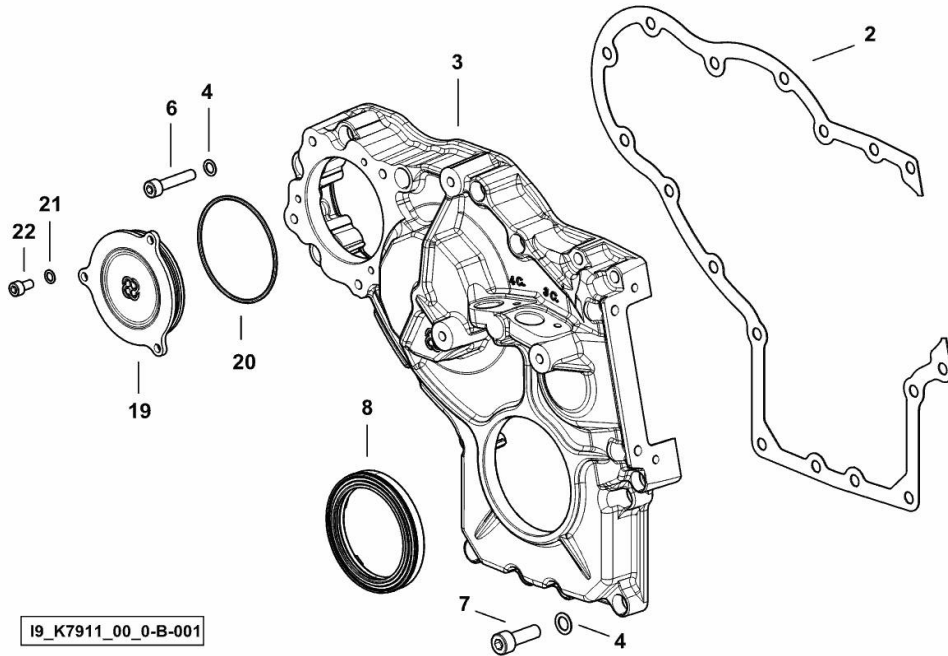

19_K7911_00_0-B-001

CASING COVER

Fig.	P/n	QTY	Name
------	-----	-----	------

Notes:

[XB 105.4 T4i -> ZKDCG90200TH20001]

30	0.065.1152.0	1	gasket
31	0.065.1151.0	1	cover
32	2.0112.205.2	2	screw m 8 p.1.25 x 16
34	2.0432.005.7	2	stud bolt m 8 p.1.5 / p.1 x 25
35	2.1310.004.2	4	flat washer 8.4x17
36	2.1470.004.2	4	lock washer 8
37	2.1011.105.2	2	nut m 8 p.1.25

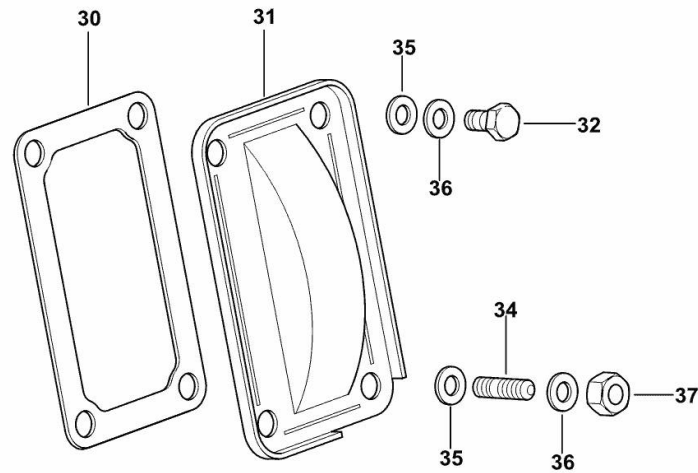

19_M7611_04_0-A-00

<https://www.ebooklibonline.com>

Hello dear friend!

Thank you very much for reading.

Enter the link into your browser.

The full manual is available for immediate download.

<https://www.ebooklibonline.com>