

**4WD - FRONT DIFFERENTIAL LOCK- STANDARD SEALING**

<b>Fig.</b>	<b>P/n</b>	<b>QTY</b>	<b>Name</b>
-------------	------------	------------	-------------

**Notes:**

[XB 100 T ->1001]

1	2.1529.149.0	1	special oil seal 55 x 80 x 12.5
2	2.1549.459.0	1	spacer 35x55x19

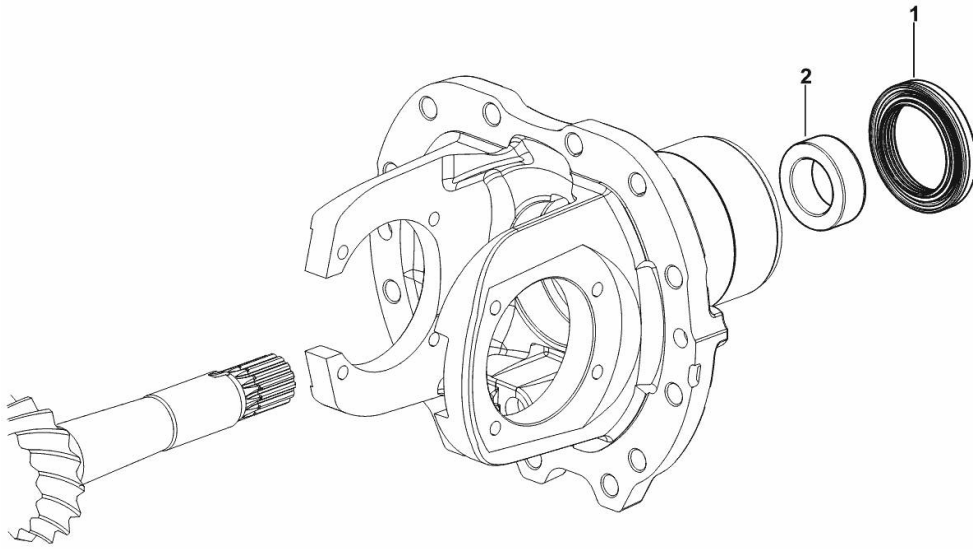

9\_Y6946\_01\_0-B-001

**4WD - FRONT DIFFERENTIAL**

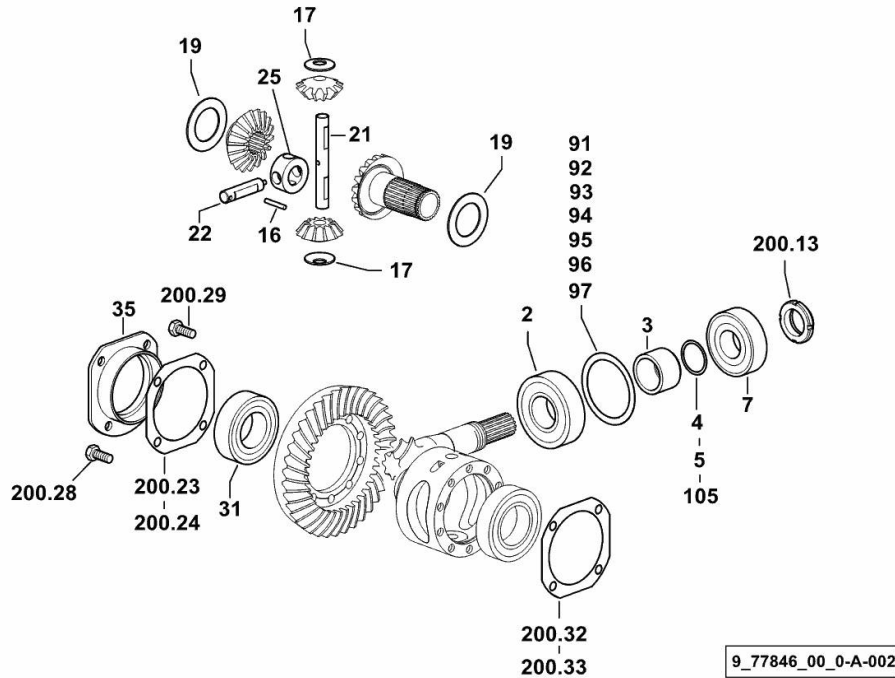

Fig.	P/n	QTY	Name
<b>Notes:</b>			
[XB 100 T ->1001]			
2	2.2560.006.0	1	roller bearing 40 x 90 x 25.25
3	0.010.1045.0	1	spacer mm 37
4	2.1580.101.0	2	shim 36 x 43 x 0.2
5	2.1580.102.0	3	shim 36 x 43 x 0.5
7	2.2560.005.0	1	roller bearing 35 x 80 x 22.75
16	2.1631.418.0	2	pin 5 x 45
17	0.255.4629.0	4	shoulder ring 15.5x36x2
19	2.1599.431.0	2	shoulder ring 42x66x2
21	0.013.6067.0	1	pin
22	0.013.6068.0	2	pin
25	0.013.6070.0	1	ring
31	2.2540.005.0	1	roller bearing 45 x 85 x 24.75
35	0.255.4652.0/20	1	flange
91	2.1589.356.0	1	shoulder ring 73x89.5x0.6
92	2.1589.357.0	0.3	shoulder ring 73x89.5x0.7
93	2.1589.358.0	0.3	shoulder ring 73x89.5x0.8
94	2.1589.359.0	0.3	shoulder ring 73x89.5x0.9
95	2.1589.360.0	0.3	shoulder ring 73x89.5x1.65
96	2.1589.361.0	0.3	shoulder ring 73x89.5x1.75
97	2.1589.362.0	0.3	shoulder ring 73x89.5x1.85
105	2.1580.109.0	2	shim 36x43x0.15
200.13	2.1214.108.7	1	ring nut m 35 p.1.5 SX
200.23	0.445.4656.0/10	2	shim 92x127x0.2
200.24	0.445.4655.0/10	2	shim 92x127x0.5
200.28	2.0132.207.2	8	screw m 10 p.1 x 25
200.29	2.0139.025.1	10	screw m 10 p.1.25 x 25
200.32	0.146.4653.0/10	4	shim 96x127x0.2
200.33	0.146.4654.0/10	4	shim 96x127x0.5

**4WD - FRONT DIFFERENTIAL**

Fig.	P/n	QTY	Name
------	-----	-----	------

**Notes:**  
[XB 100 T ->1001]

15	0.013.6062.0/40	1	differential carrier ( -> 1001 )
20	0.013.6076.3/20	1	crown wheel ( -> 1001 ) 4 PLANET PINIONS
22	2.2520.011.0	1	roller bearing 50x90x21.75
26	0.467.4650.0/30	1	flange
36	0.255.4615.0/40	1	flange
37	0.255.4617.0	1	sleeve
52	0.255.4618.0/10	1	sleeve
53	0.255.4619.0/10	1	spacer ( -> 1001 )
54	2.1599.317.0/10	2	shim 38 x 44.50 x 2 ( -> 1001 )
55	2.1580.130.0	4	shim 38.5 x 44.50 x 0.5
56	2.1580.131.0	4	shim 38.5 x 44.50 x 0.2
57	2.1412.014.7	1	circlip 38x2.5 ( -> 1001 )
58	2.2810.006.0	17	ball 3/8"
59	2.0139.002.1	10	screw m 10 p.1.25 x 20
84	0.007.2705.2/10	1	lever
85	0.467.4657.0/10	1	fork
87	0.467.4659.0/10	1	ferrule
88	0.467.4660.0	2	shoe
89	2.4019.397.2	1	spring
90	2.4049.184.2	1	spring 12.4x18x2.8x56
91	0.272.4651.0	2	spacer
92	2.1530.043.0	1	oil seal 17.13x2.62
93	0.007.6282.0/30	1	piston
94	2.1011.103.2	1	nut m 6 p.1
95	2.1310.002.2	1	flat washer 6.4x12.5
96	2.1530.062.0	1	oil seal 23.81 x 2.62
97	2.1630.511.0	1	roll pin 5x24
98	2.1671.103.2	1	pin 6x18
99	2.1690.205.2	1	split pin 2x12
100	2.3510.003.2	1	fork m 6
101	0.009.7877.0/10	1	small plate
103	2.1470.002.2	2	lock washer 6
104	2.0112.005.2	2	screw m 6 p.1 x 16
105	2.1659.523.0	4	pin 10 x 16

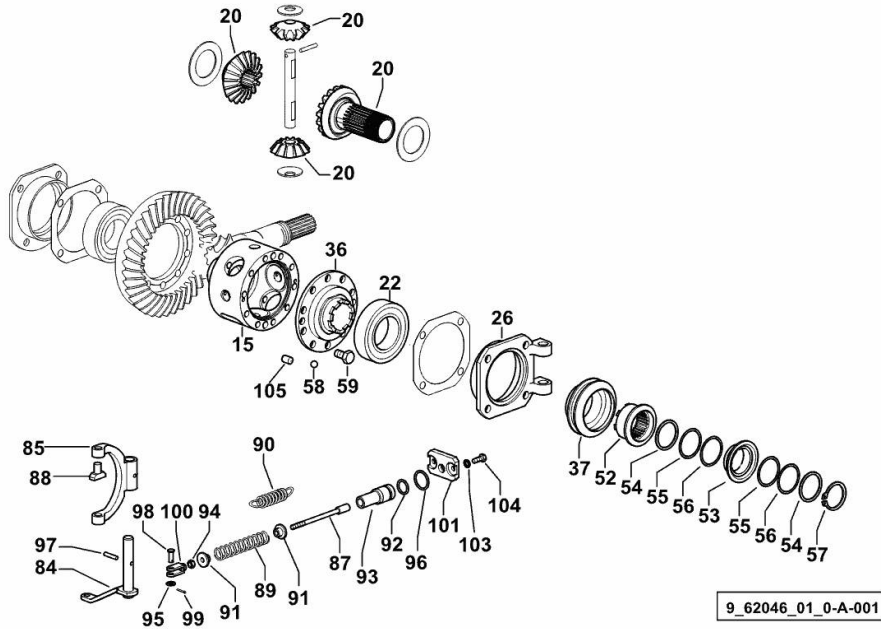

**<https://www.ebooklibonline.com>**

Hello dear friend!

Thank you very much for reading.

Enter the link into your browser.

The full manual is available for immediate download.

**<https://www.ebooklibonline.com>**

**4WD - TRANSMISSION SHAFT**

Fig.	P/n	QTY	Name
------	-----	-----	------

**Notes:**

[XB 100 T ->1001]

1	0.011.0842.2	1	transmission shaft mm 849
2	2.1631.718.0	2	roll pin 8 x 45
4	0.255.2617.0/10	2	sleeve
6	2.1499.528.1	2	circlip 30
7	2.1411.025.1	2	circlip 62
8	2.2999.008.0	1	special bearing 30x62x23.8
9	0.014.3398.0/10	1	transmission shaft mm 642
10	0.010.7164.2/70	1	shield
11	2.1470.004.2	2	lock washer 8
12	2.1011.408.2	2	nut m 14 p.1.5
13	2.0112.209.2	2	screw m 8 p 1.25 x 25
14	2.1475.005.2	2	washer 14
15	2.1579.987.2	2	spacer 8.5x16x8

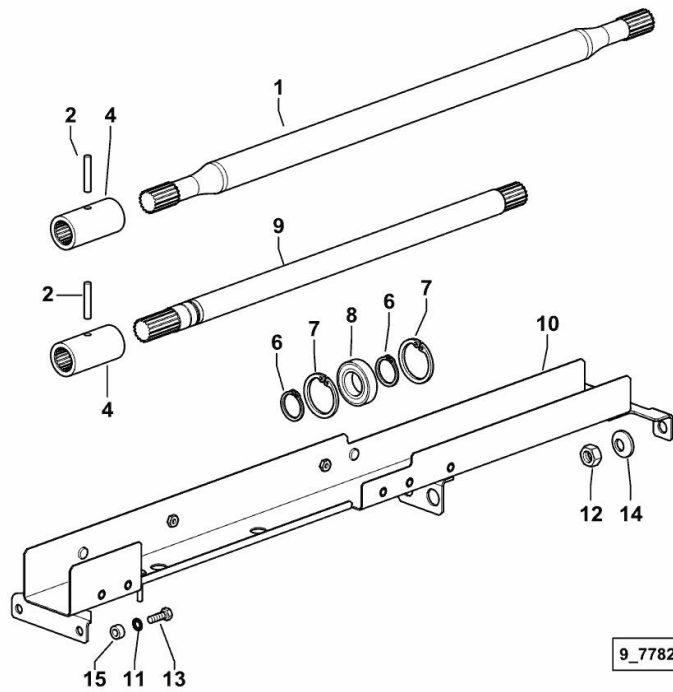

**4WD - TRANSMISSION SHAFT - WITH STANDARD SEALS**

<b>Fig.</b>	<b>P/n</b>	<b>QTY</b>	<b>Name</b>
-------------	------------	------------	-------------

**Notes:**  
[XB 100 T ->1001]

1	0.014.3406.0	1	bushing
---	--------------	---	---------

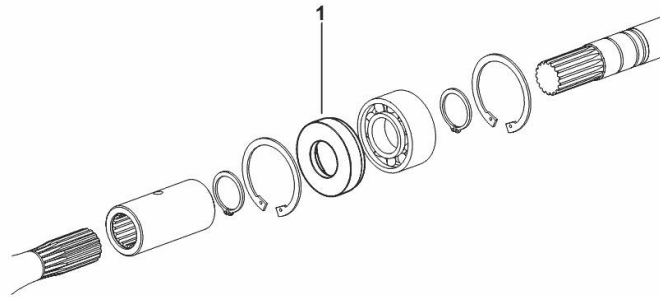

9\_B7826\_02\_0-A-001

Section: F0 - FRONT AXLE  
**STEERING CYLINDER - 4WD**

Fig.	P/n	QTY	Name
------	-----	-----	------

**Notes:**

[XB 100 T ->1001] 1001 <-

1	0.010.6110.4/20	2	cylinder ☞ 0.010.6110.4/20
2	0.016.1031.2	2	piston pin
3	2.1579.739.0	8	spacer 21x25x10
4	0.270.6351.0	8	rubber ring
5	2.3820.105.2	2	grease gun m 10 p.1 x 7
6	2.0112.207.2	2	screw m 8 p 1.25 x 20
7	2.1470.004.2	2	lock washer 8
8	2.3821.303.2	2	grease gun m 10 p.1
50	0.016.1025.0	2	piston pin
51	2.0399.050.2	2	screw m 10 p.1 x 30
52	2.1011.406.2	2	nut m 10 p.1
56	0.011.0400.2/10	1	guard sx/lh/li
57	0.011.0402.2/10	1	guard dx/rh/re
58	2.1310.006.2	2	flat washer 10.5x21
59	2.0112.307.2	2	screw m 10 p.1.5 x 20
60	2.1310.004.2	2	flat washer 8.4x17
61	2.0112.205.2	2	screw m 8 p.1.25 x 16
62	0.010.6309.2/20	1	guard

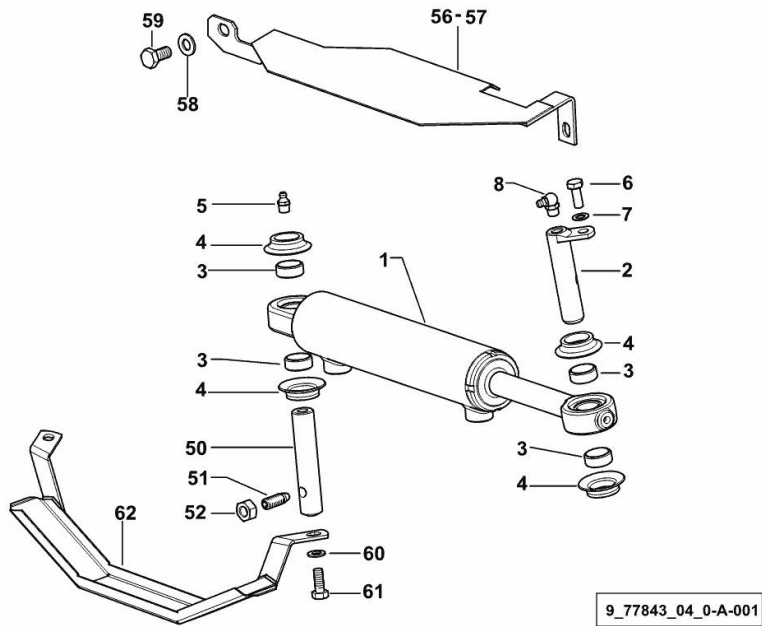

Section: F0 - FRONT AXLE  
**STEERING CYLINDER - 4WD**

Fig.	P/n	QTY	Name
------	-----	-----	------

Notes:  
 [XB 100 T ->1001]

1	0.010.6110.4/30	2	cylinder ☞ 0.010.6110.4/30
2	0.016.1031.2	2	piston pin
3	2.1579.739.0	8	spacer 21x25x10
4	0.270.6351.0	8	rubber ring
6	2.0119.326.2/10	2	screw m 8 p 1.25 x 20
7	2.1470.004.2	2	lock washer 8
8	2.3821.303.2	4	grease gun m 10 p.1
50	0.016.1025.0/10	2	piston pin
51	2.0399.378.2/10	2	screw m 10 p.1x35
52	2.1011.406.2	2	nut m 10 p.1
56	0.011.0400.2/10	1	guard sx/lh/li
57	0.011.0402.2/10	1	guard dx/rh/re
58	2.1310.006.2	2	flat washer 10.5x21
59	2.0112.307.2	2	screw m 10 p.1.5 x 20
60	2.1310.004.2	2	flat washer 8.4x17
61	2.0112.205.2	2	screw m 8 p.1.25 x 16
62	0.010.6309.2/20	1	guard
65	2.1430.013.7	2	circlip 15

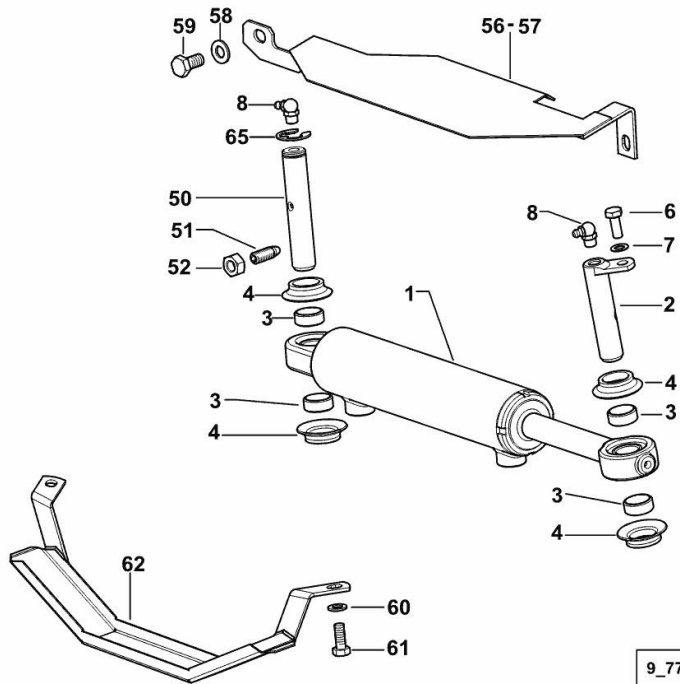

9\_77843\_04\_0-A-002

**CYLINDER PARTS**

Fig.	P/n	QTY	Name
1	0.010.6110.4/20	1	cylinder
2	2.1421.019.1	1	circlip
3	0.176.6372.0	1	ring nut
4	0.463.6355.1	1	self-locking nut m 16 p.1.5
5	2.1423.026.1	4	shoulder ring
6	0.176.6371.0	2	cap
7	0.000.0000.1		cannot be supplied
8	0.176.6377.1	1	piston mm 48
9	0.176.6375.0	1	special bushing
10	0.009.4734.2	1	seal ring kit

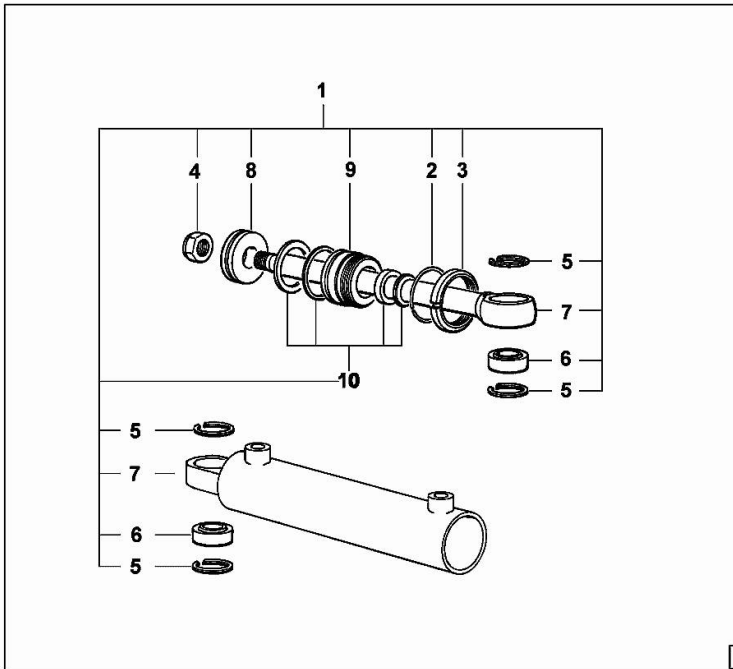

010\_6110\_4\_20

**CYLINDER PARTS**

Fig.	P/n	QTY	Name
1	0.010.6110.4/30	1	cylinder
2	2.1421.019.1	1	circlip
3	0.176.6372.0	1	ring nut
4	0.463.6355.1	1	self-locking nut m 16 p.1.5
5	2.1423.026.1	4	shoulder ring
6	0.176.6371.0	2	cap
7	0.000.0000.1		cannot be supplied
8	0.176.6377.1	1	piston mm 48
9	0.176.6375.0	1	special bushing
10	0.009.4734.2	1	seal ring kit

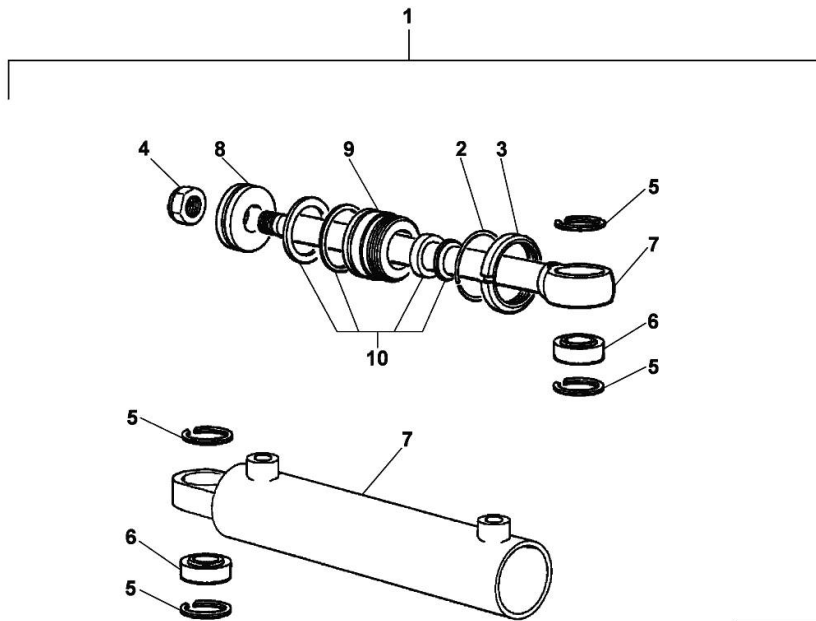

0.010.6110.4/30



**Suggest:**

**For more complete manuals. Please go to the home page.**

**<https://www.ebooklibonline.com>**

**If the above button click is invalid. Please download this document first, and then click the above link to download the complete manual.**

**Thank you so much for reading**

**4 WD - FRONT REDUCTION UNIT AND HALFSHAFTS**

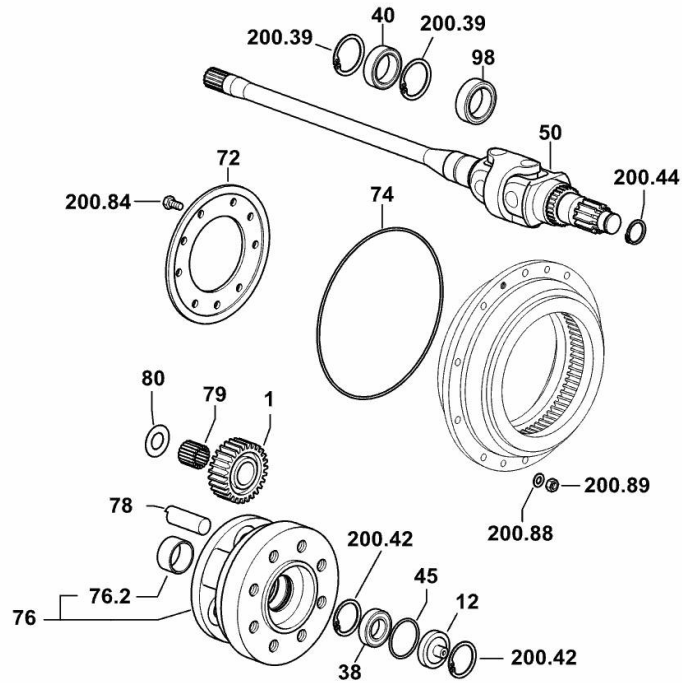

9\_77846\_00\_0-B-002

Fig.	P/n	QTY	Name
<b>Notes:</b>			
[XB 100 T ->1001]			
1	0.255.4644.0/20	6	planet gear z=27
12	0.275.4653.0	2	small cover
38	2.2030.007.0	2	ball bearing 30x55x13
40	2.2999.415.0	1	special bearing 43.8 x 62 x 17
45	2.1530.134.0	2	oil seal 53.98x3.53
50	0.010.5413.4/20	2	half-shaft ( -> 1001 ) ☞ 0.010.5413.4/20
72	0.275.4650.0/10	2	flange
74	2.1530.308.0	2	oil seal 253.6x3.53
76	0.275.4642.3/40	2	spider
76.2	2.1559.067.0	1	special bushing 44.1x50.1x25
78	0.198.4643.0	6	pin
79	2.2999.002.0	6	roller cage 25x35x30
80	2.1599.871.0	12	slewing ring 25x48x1
98	2.1529.112.0	2	special oil seal 45 x 65 x 18.5
200.39	2.1411.025.1	4	circlip 62
200.42	2.1411.022.1	4	circlip 55
200.44	2.1499.528.1	2	circlip 30
200.84	2.0139.002.1	18	screw m 10 p.1.25 x 20
200.88	2.1475.203.7	20	washer 10.5
200.89	2.1012.421.7	20	nut m 10 p.1.25

**4WD - FRONT REDUCTION UNIT FOR TYPES WITH BRAKES**

<b>Fig.</b>	<b>P/n</b>	<b>QTY</b>	<b>Name</b>
-------------	------------	------------	-------------

**Notes:**

[XB 100 T ->1001]

76	0.011.0665.3	2	crown wheel
----	--------------	---	-------------

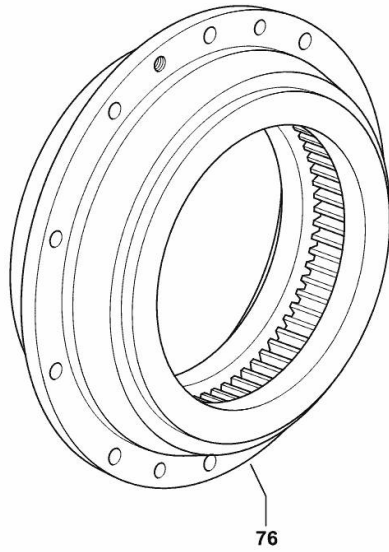

9\_77843\_02\_0-B-001

**<https://www.ebooklibonline.com>**

Hello dear friend!

Thank you very much for reading.

Enter the link into your browser.

The full manual is available for immediate download.

**<https://www.ebooklibonline.com>**