

CRANKCASE

Fig.	P/n	QTY	Name
------	-----	-----	------

Notes:

[XA 80 TRADITION -> 30001]

19_K7711_00_0-A-001

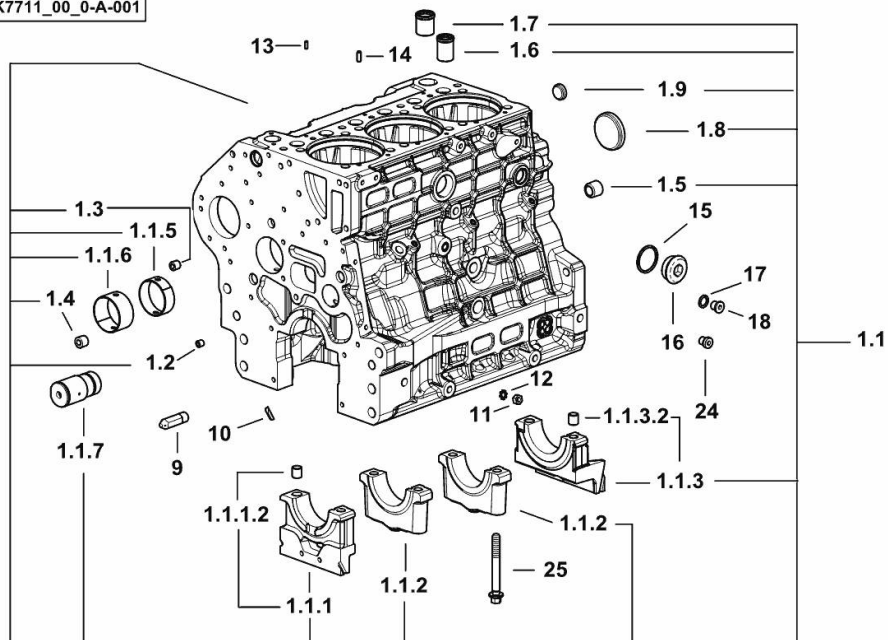

1.1	0.020.4331.3/20	1	crankcase
1.1.1	0.019.5106.3	1	support
1.1.1.2	2.1699.165.0	1	bush 12.3x15x16
1.1.2	0.019.5107.7	2	support
1.1.3	0.019.5108.3	1	support
1.1.3.2	2.1699.165.0	1	bush 12.3x15x16
1.1.5	0.065.1140.0	3	special bushing 59X55X20
1.1.6	0.065.1141.0	1	special bushing 59X55X30
1.1.7	0.019.4412.0	1	pin
1.2	2.3130.001.7	12	plug
1.3	2.3130.002.7	2	plug 1/4" gas
1.4	2.3130.003.7	4	plug 3/8" gas
1.5	2.3130.005.7	3	plug
1.6	0.019.4146.0	1	tube
1.7	0.019.6173.0	1	tube
1.8	2.3179.012.0	1	plug 60
1.9	2.3171.010.4	5	plug 25
9	0.019.4415.0/10	1	tube
10	0.066.1152.0/10	4	gasket
11	2.1011.405.2	2	nut m 8 p.1
12	2.1470.004.2	4	lock washer 8
13	2.1651.305.0	3	pin 4 x 12
14	2.1651.507.0	3	pin 6 x 16
15	2.1560.027.0	1	copper gasket 38.3x44
16	2.3139.031.2	1	plug
17	2.1560.010.0	1	gasket 14.2 x 20
18	2.3199.292.0	1	plug 1/4" gas
24	2.3139.024.2	1	plug m 12 p.1.5 (-> 30001)
25	2.0399.367.7	8	screw

MONOBLOC ENGINE-GEARBOX CONNECTING FLANGE

Fig.	P/n	QTY	Name
------	-----	-----	------

Notes:

[XA 80 TRADITION -> 30001]

1	0.007.7752.0/30	1	flange
2	2.0112.511.2	8	screw m 14 p.2 x 30
3	2.1651.912.0	2	cylindrical plug 12x28
4	2.1651.917.0	1	cylindrical plug 12x40
5	2.0432.257.7	1	stud bolt m 12 p.1.75 - 1.25 x 30
6	2.0439.250.7	1	stud bolt m 12 / m 10 x 30
7	0.011.9294.0/10	1	bush

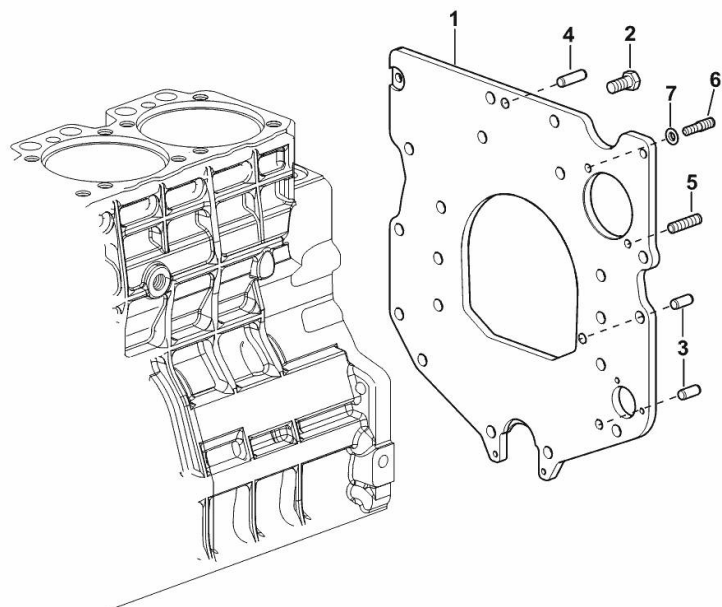

19_N8911_01_0-A-001

FITTING FOR ENGINE OIL PRESSURE SWITCH

Fig.	P/n	QTY	Name
------	-----	-----	------

Notes:

[XA 80 TRADITION -> 30001]

1	2.3120.101.0	1	plug m 18 p.1.5
2	2.1560.014.0	1	washer 18.2 x 24
3	2.3249.697.2	1	pipe union
4	2.1560.008.0	3	gasket 12.2 x 18
5	2.3249.014.2	1	pipe fitting m 12 p.1.5

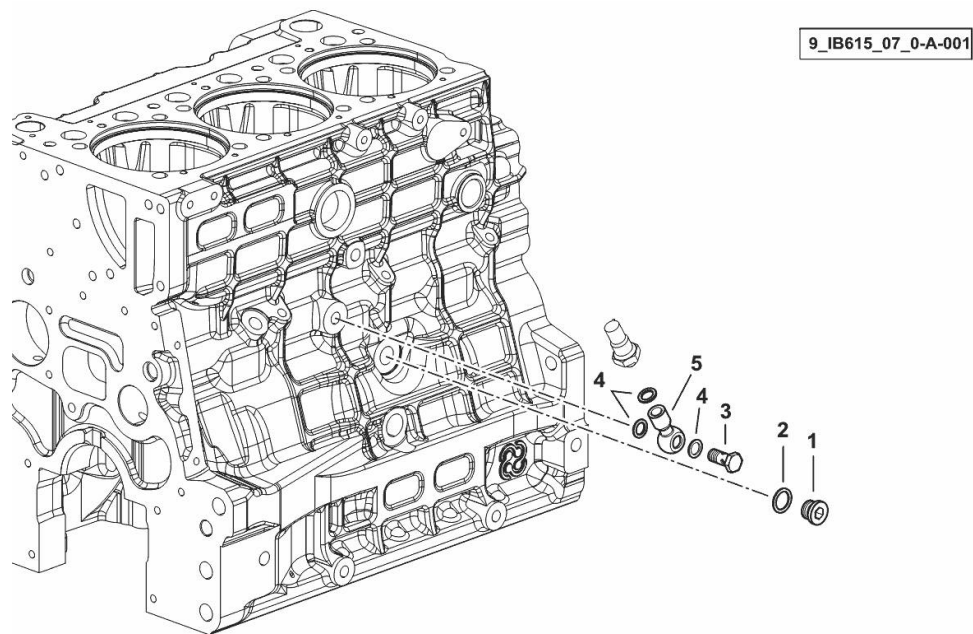

<https://www.ebooklibonline.com>

Hello dear friend!

Thank you very much for reading.

Enter the link into your browser.

The full manual is available for immediate download.

<https://www.ebooklibonline.com>

CYLINDER LINER O-RING

Fig.	P/n	QTY	Name
------	-----	-----	------

Notes:

[XA 80 TRADITION -> 30001]

16	2.1539.259.0	6	special oil seal 107.62x2.62
----	--------------	---	------------------------------

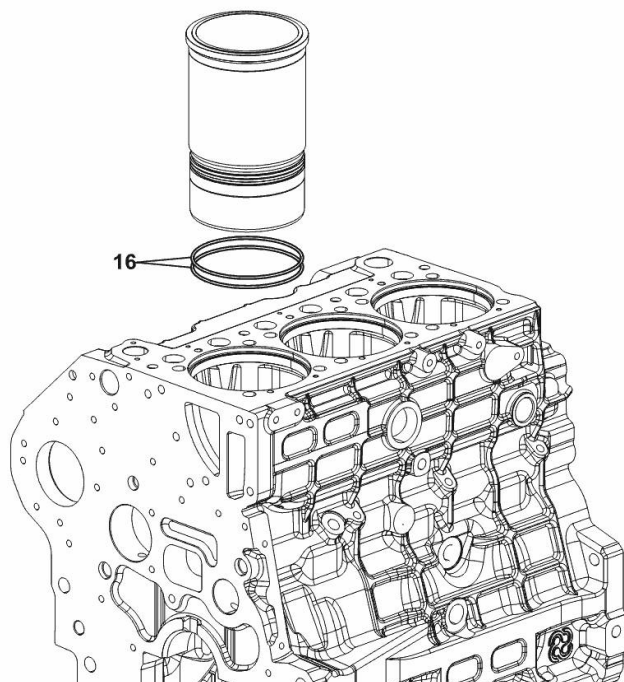

19_K7712_00_0-B-001

SIDE PLUG FOR CYLINDER BLOCK

Fig.	P/n	QTY	Name
------	-----	-----	------

Notes:

[XA 80 TRADITION -> 30001]

12	2.1560.018.0	1	gasket 22.2 x 29
13	2.3120.102.0	1	plug

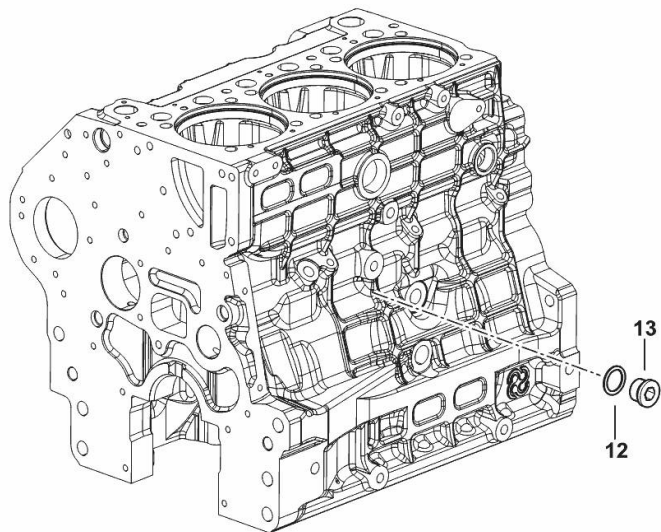

19_K7815_03_0-B-001

CRANKSHAFT

Fig.	P/n	QTY	Name
------	-----	-----	------

Notes:
 [XA 80 TRADITION -> 30001]

1	0.019.2255.3/20	1	crankshaft
1.2	0.007.0855.0/10	1	gear
1.3	2.1651.915.0	1	pin 12x35
7	0.019.5455.0	4	main half bushing STANDARD
8	0.019.5456.0	4	main half bushing STANDARD
9	2.1599.524.7	1	washer 21x60x12
10	0.065.1218.0	4	shim STANDARD
11	2.1529.073.0	1	special oil seal 110x130x13
12	0.065.1254.0/20	1	gasket
13	0.007.0851.0/10	1	cover
14	2.1475.002.7	9	washer 8.4
15	2.0112.207.2	7	screw m 8 p 1.25 x 20
20	2.0432.003.7	2	stud bolt m 8 p.1.25 / p.1 x 20
21	2.1011.405.2	2	nut m 8 p.1
1001	0.065.1218.7		shim + mm 0.10
1002	0.065.1218.8		shim + mm 0.15

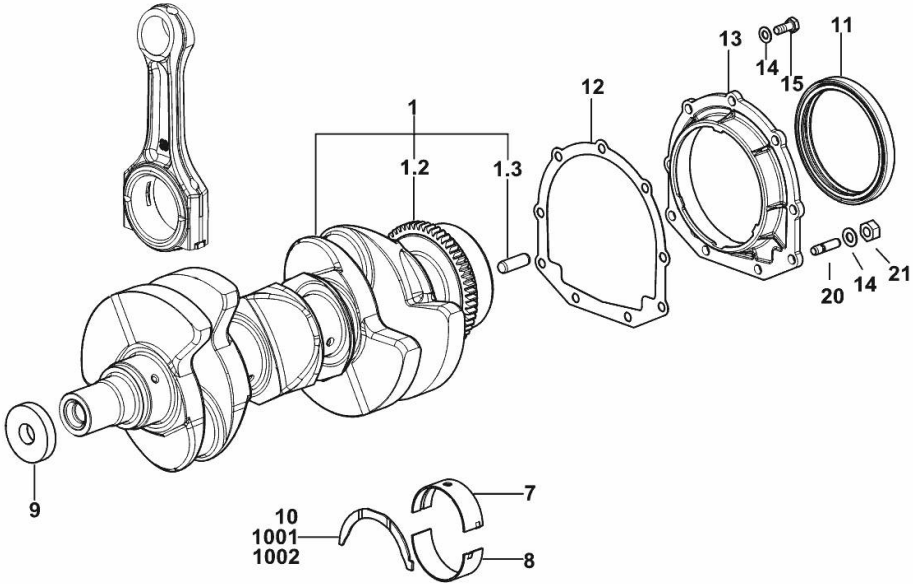

I9_K7712_00_0-A-001

CRANKSHAFT GEAR

Fig.	P/n	QTY	Name
------	-----	-----	------

Notes:

[XA 80 TRADITION -> 30001]

1	0.019.4145.0	1	gear z = 33
2	2.1720.006.0	1	key 4x6.5

I9_K7713_00_0-D-001

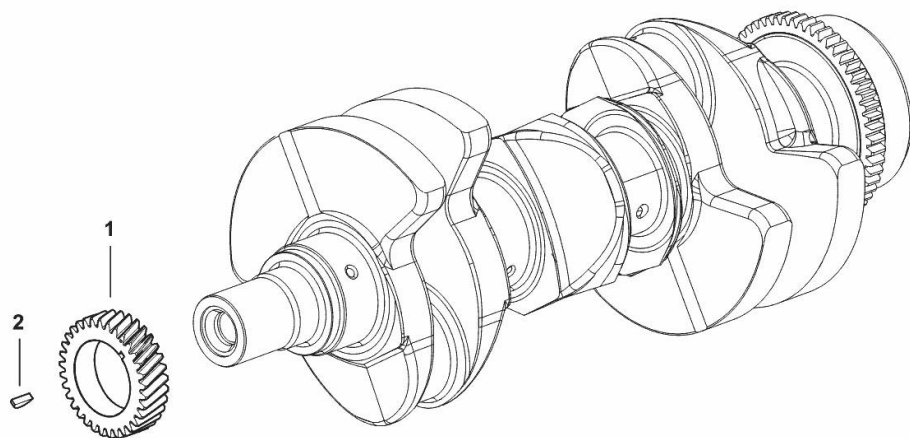

CRANKSHAFT PULLEY

Fig.	P/n	QTY	Name
------	-----	-----	------

Notes:
 [XA 80 TRADITION -> 30001]

1	0.019.9925.0	1	pulley
2	0.019.6668.0	1	flange
3	0.065.1256.0	2	ring 45x52
4	2.1579.865.0	1	spacer 45.2x51.8x10
5	2.0439.195.7	1	stud bolt m 20 p.1.5x80
6	2.1019.094.7	1	nut m 20 p.1.5
7	2.0112.320.2	6	screw m 10 p.1.5 x 55
8	2.1470.006.2	6	lock washer 10
9	2.1720.006.0	1	key 4x6.5
10	0.019.6413.0	1	gear wheel
11	2.1651.505.0	1	cylindrical plug 6x12

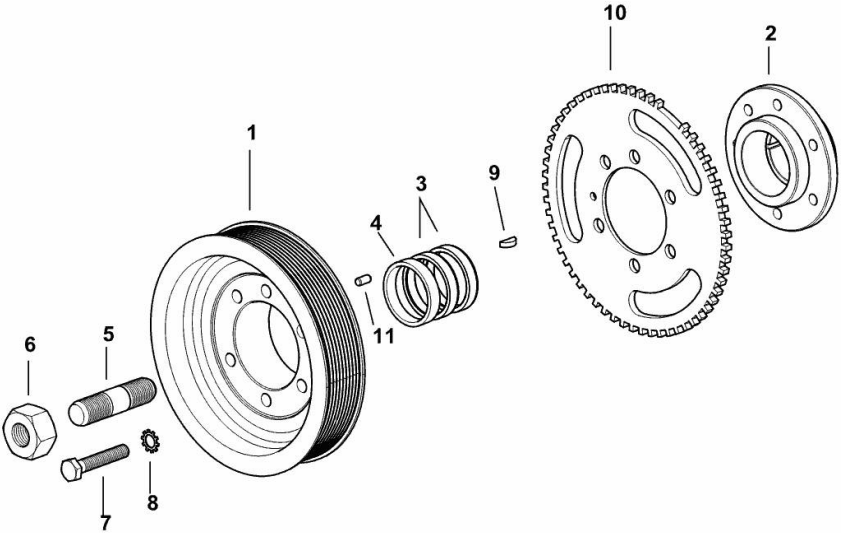

19_K7812_01_0-A-001

ENGINE FLYWHEEL

Fig.	P/n	QTY	Name
------	-----	-----	------

Notes:
[XA 80 TRADITION -> 30001]

1	0.007.1617.3/30	1	flywheel
1.2	0.069.1242.0	1	crown wheel Z = 121
2	2.0399.395.7	6	screw
3	2.2041.008.0	1	ball bearing 20x47x14

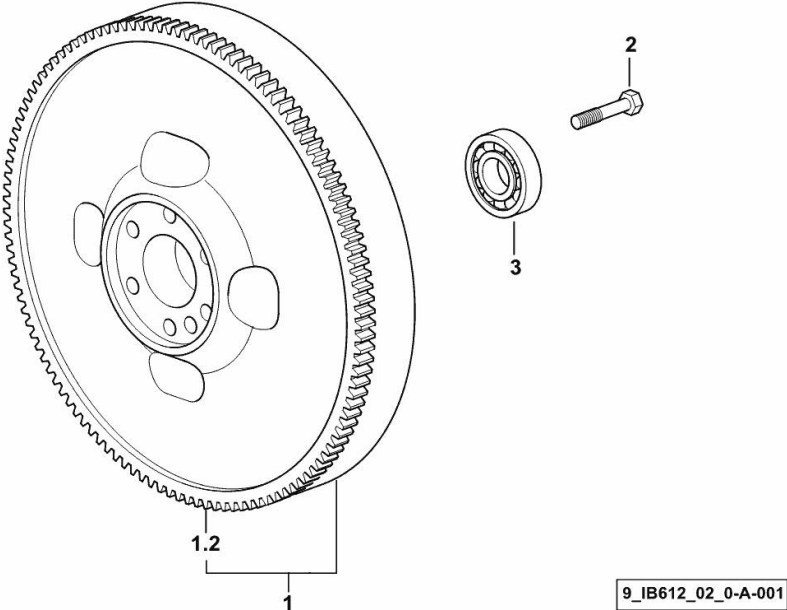



Suggest:

For more complete manuals. Please go to the home page.

<https://www.ebooklibonline.com>

If the above button click is invalid. Please download this document first, and then click the above link to download the complete manual.

Thank you so much for reading

BELT AND TENSIONER

Fig.	P/n	QTY	Name
------	-----	-----	------

Notes:
 - FOR TRACTORS WITH AIR CONDITIONING [XA 80 TRADITION -> 30001]

1	2.4119.218.0/10	1	belt PK 10 L=2017
2	0.021.4446.4	1	tensioner
3	0.019.9869.4/10	3	pulley guide
4	2.0312.214.2	5	screw m 8 p.1.25 x 40
5	0.019.8853.0/10	1	support
7	2.0399.380.2	1	screw
8	2.0399.379.2	1	small column
9	2.1480.015.2	1	washer 10
10	2.1480.014.2	5	washer 8
11	2.1310.004.2	2	flat washer 8.4x17
12	2.0314.322.2	1	screw
13	2.0112.209.2	2	screw m 8 p 1.25 x 25
14	2.1310.006.2	1	flat washer 10.5x21

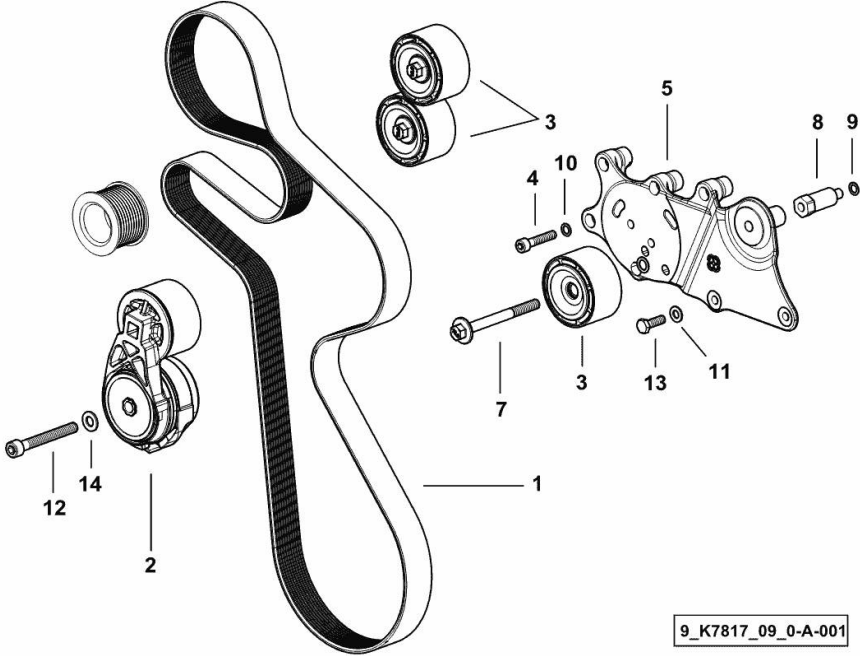

9_K7817_09_0-A-001

BELT AND TENSIONER

Fig.	P/n	QTY	Name
------	-----	-----	------

Notes:
 - FOR TRACTORS WITH AIR CONDITIONING [XA 80 TRADITION -> 30001]

1	2.4119.218.0/10	1	belt PK 10 L=2017
3	0.019.9869.4/10	3	pulley guide
4	2.0312.214.2	5	screw m 8 p.1.25 x 40
5	0.019.8853.0/10	1	support
7	2.0399.380.2	1	screw
8	2.0399.379.2	1	small column
9	2.1480.015.2	1	washer 10
10	2.1480.014.2	5	washer 8
11	2.1310.004.2	2	flat washer 8.4x17
13	2.0112.209.2	2	screw m 8 p 1.25 x 25

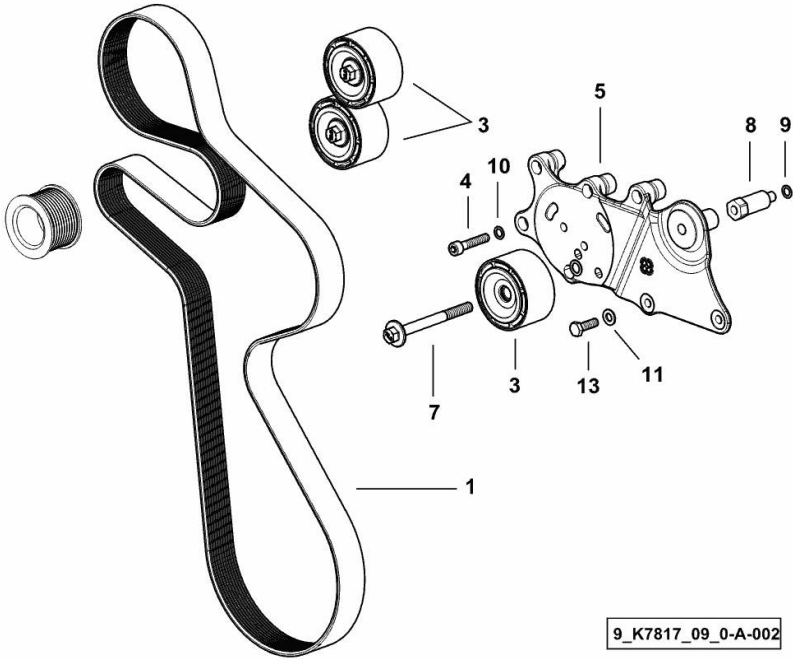

9_K7817_09_0-A-002

<https://www.ebooklibonline.com>

Hello dear friend!

Thank you very much for reading.

Enter the link into your browser.

The full manual is available for immediate download.

<https://www.ebooklibonline.com>