

Section: ENGINE
CRANKCASE

Fig.	P/n	QTY	Name
------	-----	-----	------

Notes:
 [PRINCE 435 H.D. ->1001]

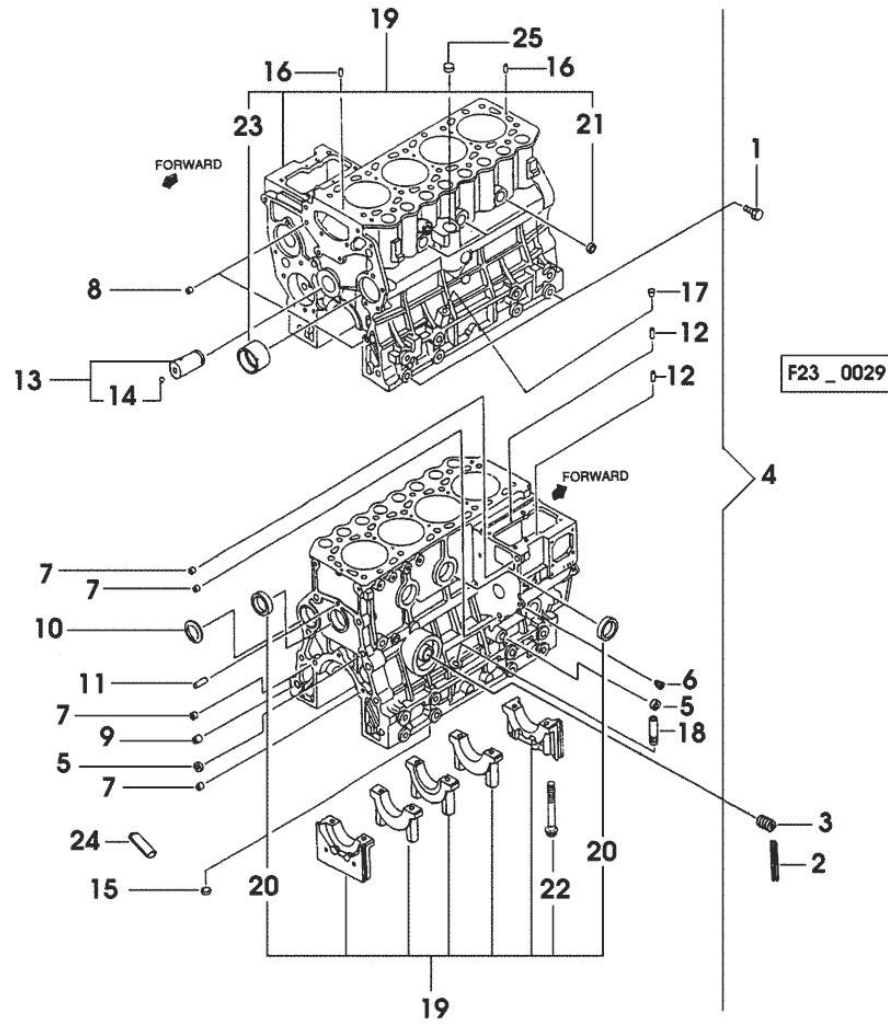

1	0.010.2648.1	4	screw
2	0.010.2651.2	4	gasket
3	0.010.2650.2	1	pipe fitting
4	0.010.2653.2	1	crankcase
			- X 35HP
4	0.010.2654.0	1	crankcase
			- X 45HP
5	0.010.2649.1	3	special bushing
6	0.009.4545.1	1	plug
7	0.009.4524.2	4	special bushing
8	0.009.4525.1	2	special bushing
9	0.009.4525.2	1	special bushing
10	0.009.4524.1	1	expansion plug
11	0.009.4524.0	1	pin
12	0.009.4523.0	2	pin
13	0.010.2650.0	1	pin
14	0.010.2650.1	1	ball
15	0.010.2649.0	1	plug
			- X 35HP
16	0.010.2651.0	2	pin
17	0.010.2651.1	1	plug
18	0.009.4523.2	1	guide
19	0.000.0000.1		cannot be supplied
20	0.010.2652.1	3	special bushing
21	0.010.2652.2	3	special bushing
22	0.010.2653.0	10	screw
23	0.010.2653.1	1	special bushing
24	0.010.2654.1	4	tube
			- X 45HP
25	0.010.2648.2	1	plug

Section: ENGINE
CRANKCASE

Fig.	P/n	QTY	Name
------	-----	-----	------

Notes:
 [PRINCE 435 H.D. ->1001]

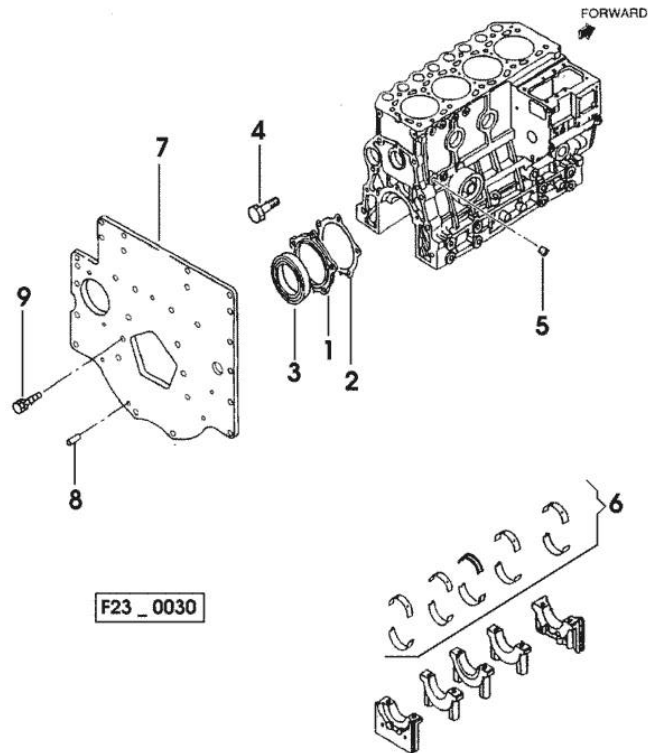

1	0.010.2654.2	1	flange
2	0.010.2655.0	1	gasket
3	0.010.2655.1	1	special oil seal
4	0.010.2655.2	5	screw
5	0.009.4530.0	1	plug - X 35HP
6	0.009.4531.0	1	main half bushing STANDARD - X 35HP
6	0.009.4531.1	1	main half bushing - mm 0.25 - X 35HP
6	0.009.4531.2	1	main half bushing - mm 0.50 - X 35HP
6	0.009.4532.0	1	main half bushing - mm 0.75 - X 35HP
6	0.010.2656.2	1	main half bushing STANDARD - X 45HP
6	0.010.2657.0	1	main half bushing - mm 0.25 - X 45HP
6	0.010.2657.1	1	main half bushing - mm 0.50 - X 45HP
6	0.010.2657.2	1	main half bushing - mm 0.75 - X 45HP
7	0.010.2656.0	1	flange
8	0.009.4532.2	1	pin
9	0.010.2656.1	6	screw

Section: ENGINE
TIMING CASE

Fig.	P/n	QTY	Name
------	-----	-----	------

Notes:
[PRINCE 435 H.D. ->1001]

1	0.010.2658.0	1	plate
2	0.010.2658.1	1	gasket
3	0.010.2639.1	10	screw
4	0.010.2658.2	1	flange
5	0.010.2659.0	1	gasket
6	0.010.2659.1	8	screw
7	0.010.2659.2	1	special oil seal
8	0.010.2660.0	1	flange
9	0.010.2660.1	1	gasket
10	0.009.4756.0	2	cover
11	0.010.2660.2	2	gasket
12	0.010.2661.0	1	screw
13	0.010.2661.1	2	nut
14	0.010.2661.2	1	screw
15	0.010.2662.0	2	screw
16	0.009.4539.2	2	spring washer
17	0.010.2662.1	1	cover
18	0.010.2662.2	4	screw
19	0.010.2663.0	4	washer

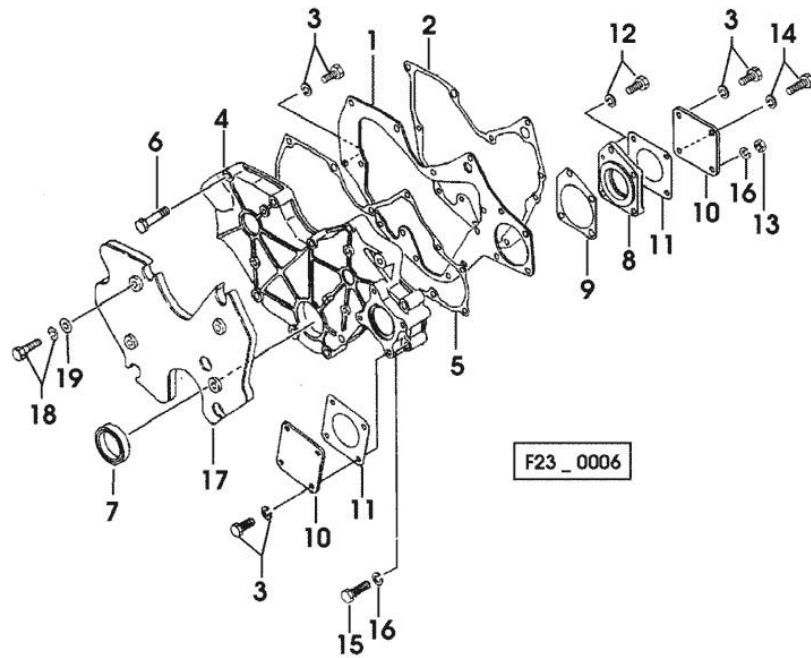

<https://www.ebooklibonline.com>

Hello dear friend!

Thank you very much for reading.

Enter the link into your browser.

The full manual is available for immediate download.

<https://www.ebooklibonline.com>

Section: ENGINE
CRANKSHAFT

Fig.	P/n	QTY	Name
------	-----	-----	------

Notes:
 [PRINCE 435 H.D. ->1001]

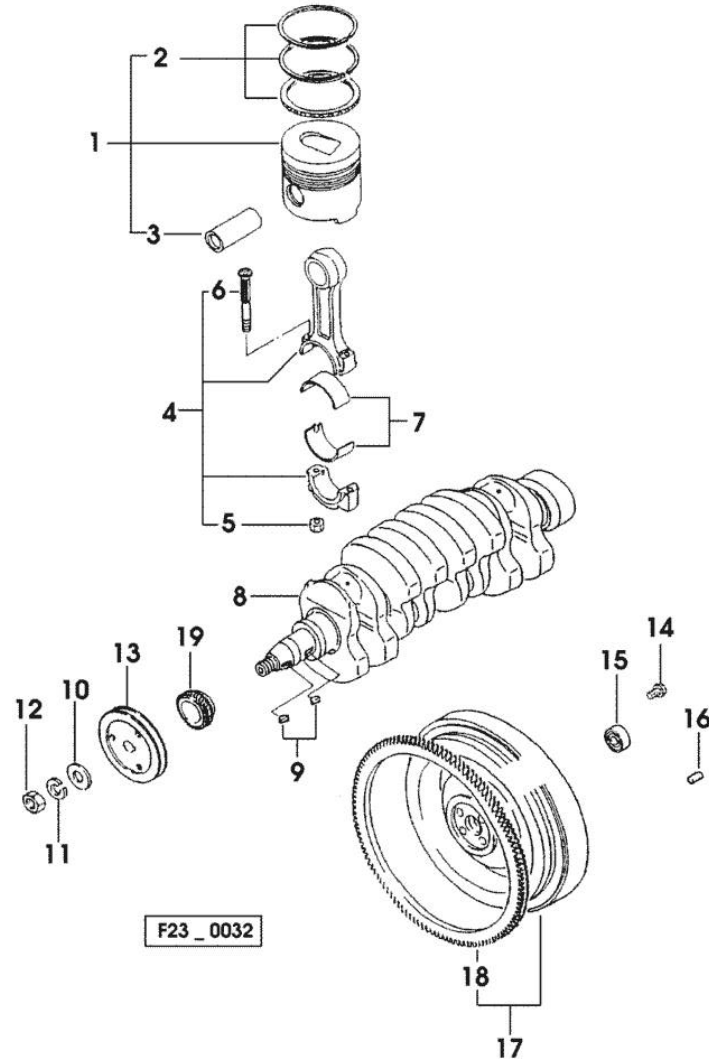

1	0.007.0060.6	4	complete piston STANDARD - X 35HP
1	0.007.0061.6	4	complete piston + mm 0.25 - X 35HP
1	0.007.0062.6	4	complete piston + mm 0.50 - X 35HP
1	0.009.0060.6	4	complete piston STANDARD - X 45HP
1	0.009.0061.6	4	complete piston + mm 0.25 - X 45HP
1	0.009.0062.6	4	complete piston + mm 0.50 - X 45HP
2	0.008.0052.6	4	piston ring set STANDARD
2	0.008.0053.6	4	piston ring set + mm 0.25
2	0.008.0054.6	4	piston ring set + mm 0.50
3	0.010.2668.0	4	piston pin
4	0.010.2671.2	4	engine connecting rod
5	0.009.4783.0	8	nut
6	0.010.2668.2	8	screw
7	0.009.4782.1	4	con.rod half bushing STANDARD
7	0.010.2669.0	4	con.rod half bushing - mm 0.25
7	0.010.2669.1	4	con.rod half bushing - mm 0.50
7	0.010.2669.2	4	con.rod half bushing - mm 0.75
8	0.010.2672.0	1	crankshaft
9	0.009.4555.1	2	key
10	0.009.4554.2	1	flat washer
11	0.009.4555.0	1	spring washer
12	0.009.4554.1	1	nut
13	0.010.2672.1	1	pulley - X 35HP
13	0.010.2672.2	1	pulley - X 45HP
14	0.009.4557.0	4	screw
15	0.009.4556.1	1	special bearing
16	0.009.4556.2	3	pin
17	0.010.2673.0	1	flywheel
18	0.010.2671.0	1	crown wheel Z=110
19	0.010.2671.1	1	gear

Section: ENGINE

CAMSHAFT

Fig.	P/n	QTY	Name
------	-----	-----	------

Notes:

[PRINCE 435 H.D. ->1001]

1	0.010.2674.1	1	gear Z = 56
2	0.010.2674.2	1	gear Z = 56
2	0.010.2675.0	1	gear Z = 56 - EXPORT U.S.A.
3	0.010.2675.1	1	gear Z = 39

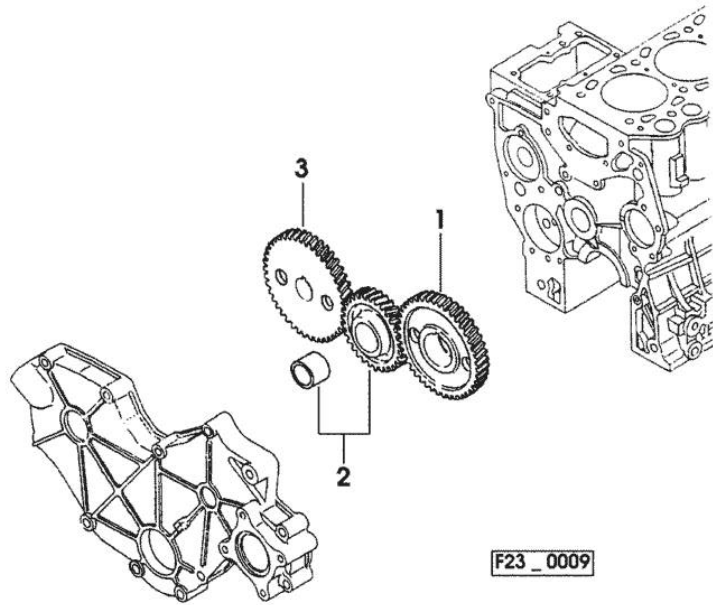

F23_0009

Section: ENGINE

CAMSHAFT

Fig.	P/n	QTY	Name
------	-----	-----	------

Notes:

[PRINCE 435 H.D. ->1001]

1	0.010.2647.1	1	cover
2	0.010.2647.2	1	gasket
3	0.010.2645.2	5	screw
4	0.009.4548.0	1	plug
5	0.010.2648.0	1	camshaft
6	0.009.4555.1	1	key
7	0.010.2646.1	1	small plate
8	0.010.2639.1	2	screw
9	0.009.4562.2	8	tappets
10	0.010.2646.2	8	rod
11	0.009.4781.2	1	tube
			- X 45HP
11	0.010.2647.0	1	tube
			- X 35HP
12	0.010.2206.0	1	clamp
			- X 45HP

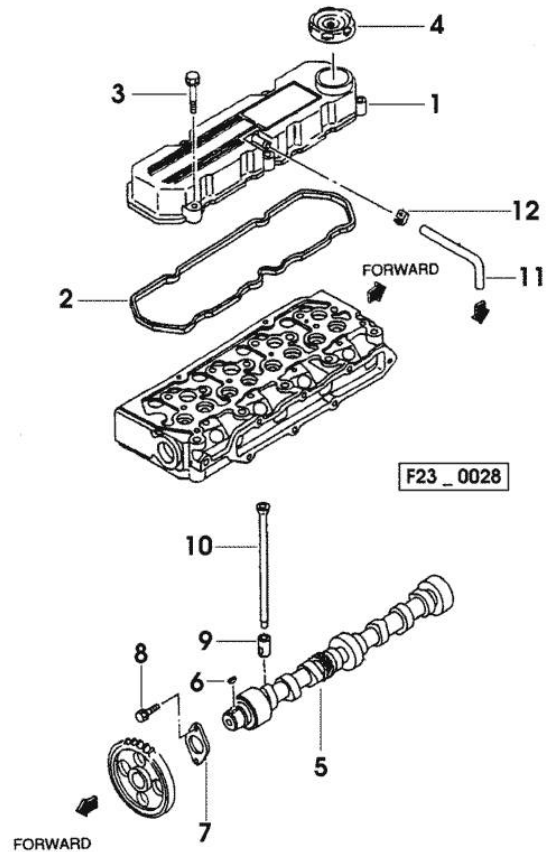

Section: ENGINE
CYLINDER HEAD

Fig.	P/n	QTY	Name
------	-----	-----	------

Notes:
[PRINCE 435 H.D. ->1001]

1	0.010.2637.2	4	inlet valve Ø mm 6.5
2	0.010.2638.0	4	exhaust valve Ø mm 6.5
3	0.010.2638.1	8	spring
4	0.010.2638.2	8	cup
5	0.009.4561.2	16	stop
6	0.009.4562.0	8	gasket
7	0.010.2639.0	8	cap
8	0.010.2639.1	1	screw
9	0.010.2644.0	1	camshaft
10	0.009.4567.0	1	special bearing
11	0.009.4566.0	1	washer
12	0.009.4567.2	1	stick
13	0.000.0000.1	1	cannot be supplied
14	0.010.2640.1	1	screw
15	0.009.4559.0	2	ring
16	0.010.2640.2	8	rocker arm
17	0.010.2641.0	8	nut
18	0.010.2641.2	8	screw
19	0.010.2642.0	1	support
20	0.010.2642.1	2	support
21	0.010.2644.1	1	shaft
22	0.010.2643.0	2	plug
23	0.010.2643.1	2	spring
24	0.010.2643.2	3	screw

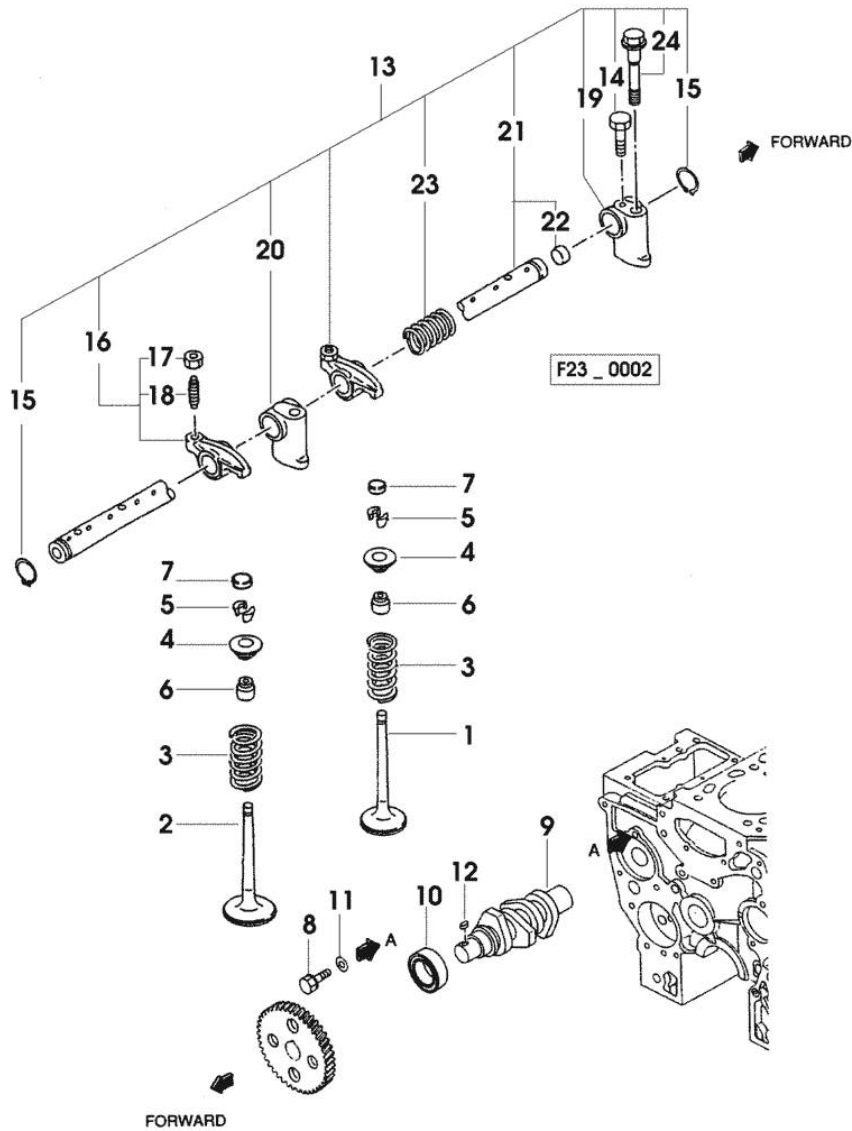

Section: ENGINE
CYLINDER HEAD

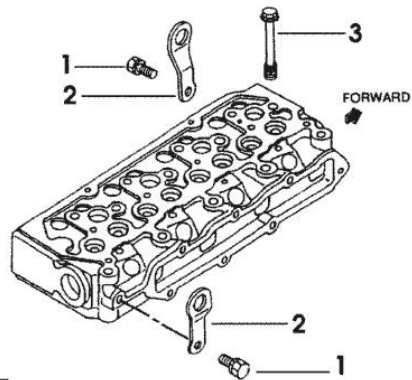
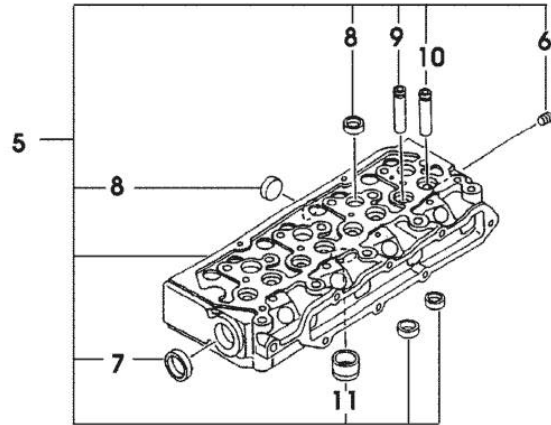

F23_0027

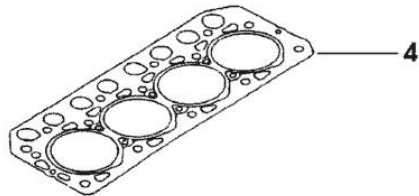

Fig.	P/n	QTY	Name
Notes:			
[PRINCE 435 H.D. ->1001]			
1	0.010.2633.0	2	screw
2	0.009.4541.2	2	bracket
3	0.010.2633.1	14	screw
4	0.010.2635.2	1	gasket
5	0.010.2636.0	1	engine head
6	0.009.4545.1	1	plug
7	0.010.2634.1	1	plug
8	0.010.2636.1	7	plug
9	0.010.2634.2	4	valve guide
10	0.010.2635.0	4	valve guide
11	0.010.2636.2	4	special bushing

Section: ENGINE
CYLINDER HEAD

Fig.	P/n	QTY	Name
------	-----	-----	------

Notes:

- EXPORT U.S.A. [PRINCE 435 H.D. ->1001]

1	0.010.2633.0	2	screw
2	0.009.4541.2	2	bracket
3	0.010.2633.1	14	screw
4	0.010.2635.2	1	gasket
5	0.010.2637.0	1	engine head
6	0.009.4545.1	1	plug
7	0.010.2634.1	1	plug
8	0.009.4527.0	7	plug
9	0.010.2634.2	4	valve guide
10	0.010.2635.0	4	valve guide
11	0.010.2637.1	4	special bushing

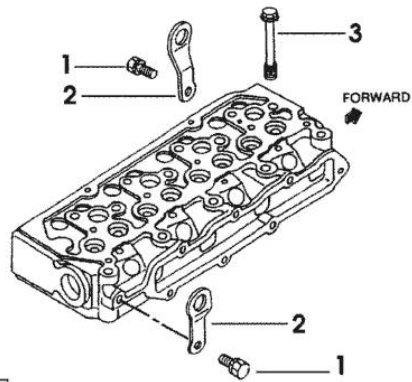
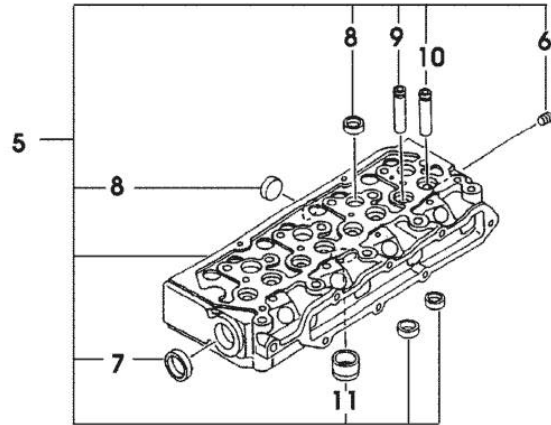

F23_0027

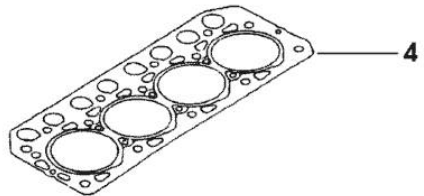



Suggest:

For more complete manuals. Please go to the home page.

<https://www.ebooklibonline.com>

If the above button click is invalid. Please download this document first, and then click the above link to download the complete manual.

Thank you so much for reading

OIL PAN

Fig.	P/n	QTY	Name
------	-----	-----	------

Notes:

[PRINCE 435 H.D. ->1001]

1	0.010.2665.2	1	oil sump
2	0.010.2663.2	1	gasket
3	0.010.2664.0	1	plug
4	0.010.2664.1	12	screw
5	0.010.2664.2	1	screw
6	0.010.2665.0	4	screw
7	0.010.2665.1	5	washer

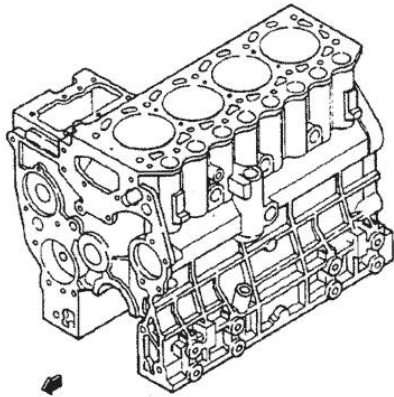

FORWARD

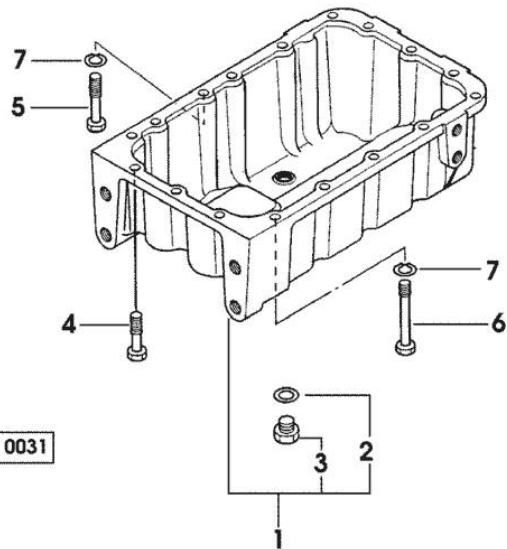

F23_0031

Section: ENGINE
LUBRICATION

Fig.	P/n	QTY	Name
------	-----	-----	------

Notes:
 [PRINCE 435 H.D. ->1001]

1	0.010.2685.2	1	tube
2	0.009.4634.0	1	self-locking nut
3	0.009.4634.1	1	gasket
4	0.010.2686.0	1	valve
5	0.010.2686.1	1	gasket
6	0.009.4794.1	1	oil filter element - X 25HP - 35HP
6	0.010.2687.0	1	oil filter element - X 45HP
7	0.010.2687.1	1	dipstick

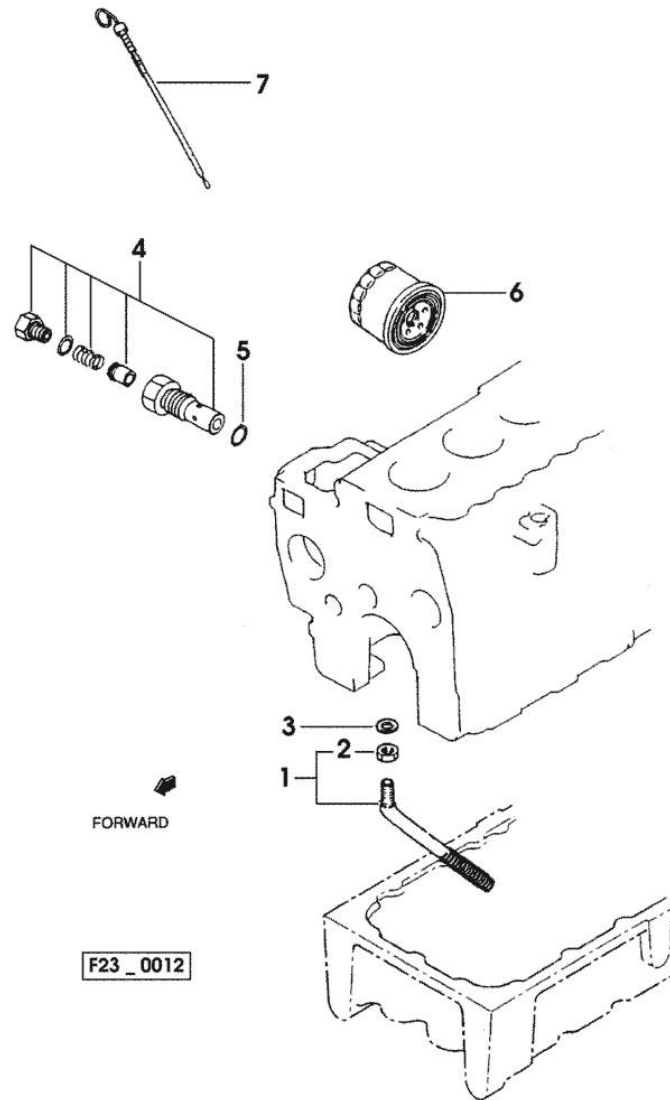

<https://www.ebooklibonline.com>

Hello dear friend!

Thank you very much for reading.

Enter the link into your browser.

The full manual is available for immediate download.

<https://www.ebooklibonline.com>