

Section: ENGINE

CRANKCASE

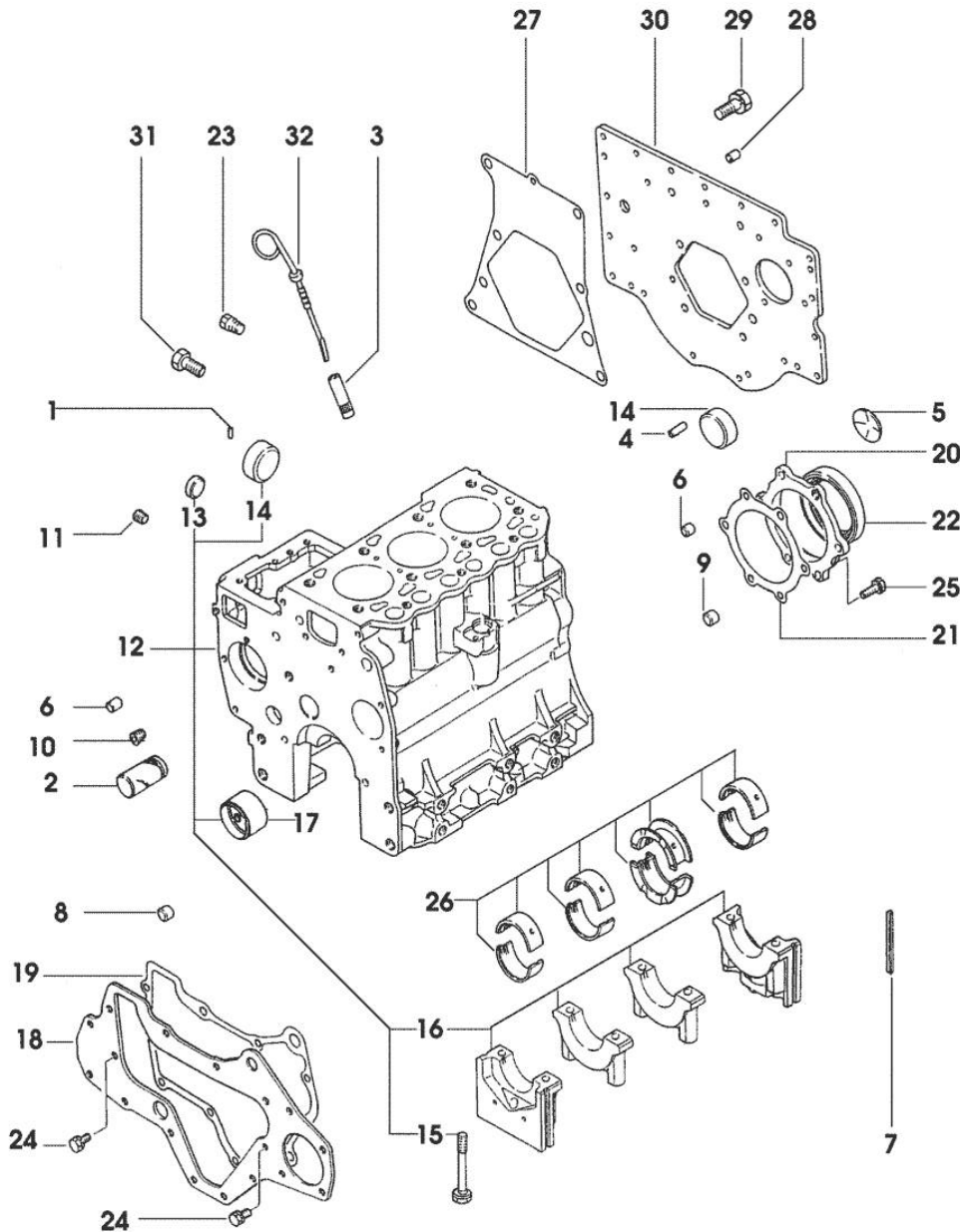

Fig.	P/n	QTY	Name
------	-----	-----	------

Notes:
[PRINCE 325 XV]

1	0.009.4523.0	2	pin
2	0.009.4523.1	1	shaft
3	0.009.4523.2	1	guide
4	0.009.4524.0	1	pin
5	0.009.4524.1	1	expansion plug
6	0.009.4524.2	2	special bushing
7	0.009.4525.0	4	gasket
8	0.009.4525.1	2	special bushing
9	0.009.4525.2	1	special bushing
10	0.009.4526.0	1	plug
11	0.009.4526.1	2	plug
12	0.009.4755.4	1	crankcase
13	0.009.4527.0	2	plug
14	0.009.4527.1	3	plug
15	0.009.4527.2	8	screw
16	0.000.0000.1		cannot be supplied
17	0.009.4528.0	1	special bushing
18	0.009.4528.1	1	plate
19	0.009.4528.2	1	gasket
20	0.009.4529.0	1	flange
21	0.009.4529.1	1	gasket
22	0.009.4529.2	1	special oil seal
23	0.009.4530.0	1	plug
24	0.009.4530.1	3	screw
25	0.009.4530.2	6	screw
26	0.009.4754.0	1	main half bushing STANDARD
26	0.009.4754.1	1	main half bushing - mm 0.25
26	0.009.4754.2	1	main half bushing - mm 0.50
26	0.009.4754.3	1	main half bushing - mm 0.75
27	0.009.4532.1	1	gasket
28	0.009.4532.2	1	pin
29	0.009.4533.0	6	screw
30	0.008.6506.0/40	1	plate
31	0.009.4533.1	4	screw
32	0.009.4533.2	1	level indicator

531 - 1

Section: ENGINE
TIMING CASE

Fig.	P/n	QTY	Name
------	-----	-----	------

Notes:
[PRINCE 325 XV]

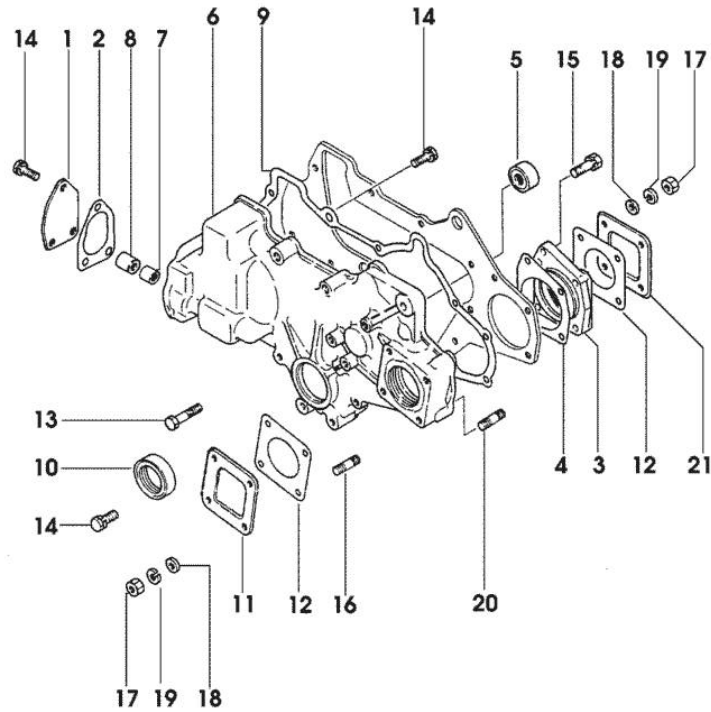

1	0.009.4534.0	1	cover
2	0.009.4534.1	1	gasket
3	0.009.4534.2	1	flange
4	0.009.4535.0	1	gasket
5	0.009.4535.1	1	plug
6	0.009.4535.2	1	distr. box
7	0.009.4536.0	1	special bearing
8	0.009.4536.1	1	special bearing
9	0.009.4536.2	1	gasket
10	0.009.4537.0	1	gasket
11	0.009.4537.1	1	cover
12	0.009.4537.2	2	gasket
13	0.009.4538.0	8	screw
14	0.009.4530.1	9	screw
15	0.009.4538.1	1	screw
16	0.009.4538.2	1	stud bolt
17	0.009.4539.0	4	nut
18	0.009.4539.1	4	flat washer
19	0.009.4539.2	4	spring washer
20	0.009.4540.0	3	stud bolt
21	0.009.4756.0	1	cover

531 - 2

Section: ENGINE
CRANKSHAFT

Fig.	P/n	QTY	Name
------	-----	-----	------

Notes:
 [PRINCE 325 XV]

1	0.361.0060.6	3	complete piston STANDARD
1	0.361.0061.6	3	complete piston + mm 0.25
1	0.361.0062.6	3	complete piston + mm 0.50
2	0.000.0000.1		cannot be supplied
3	0.361.0052.6	3	piston ring set STANDARD
3	0.361.0053.6	3	piston ring set + mm 0.25
3	0.361.0054.6	3	piston ring set + mm 0.50
4	0.009.4550.1	6	circlip
5	0.009.4550.4	3	engine connecting rod
6	0.009.4551.0	6	nut
7	0.009.4551.1	6	screw
8	0.000.0000.1		cannot be supplied
9	0.009.4551.2	3	con.rod half bushing STANDARD
9	0.009.4552.0	3	con.rod half bushing - mm 0.25
9	0.009.4552.1	3	con.rod half bushing - mm 0.50
9	0.009.4552.2	3	con.rod half bushing - mm 0.75
10	0.009.4553.0	3	special bushing
11	0.009.4756.1	1	crankshaft
12	0.009.4756.2	1	pulley
13	0.009.4554.0	1	gear
14	0.009.4554.1	1	nut
15	0.009.4554.2	1	flat washer
16	0.009.4555.0	1	spring washer
17	0.009.4555.1	2	key
18	0.009.4555.4	1	flywheel
19	0.009.4556.0	1	crown wheel
20	0.009.4556.1	1	special bearing
21	0.009.4556.2	3	pin
22	0.009.4557.0	5	screw

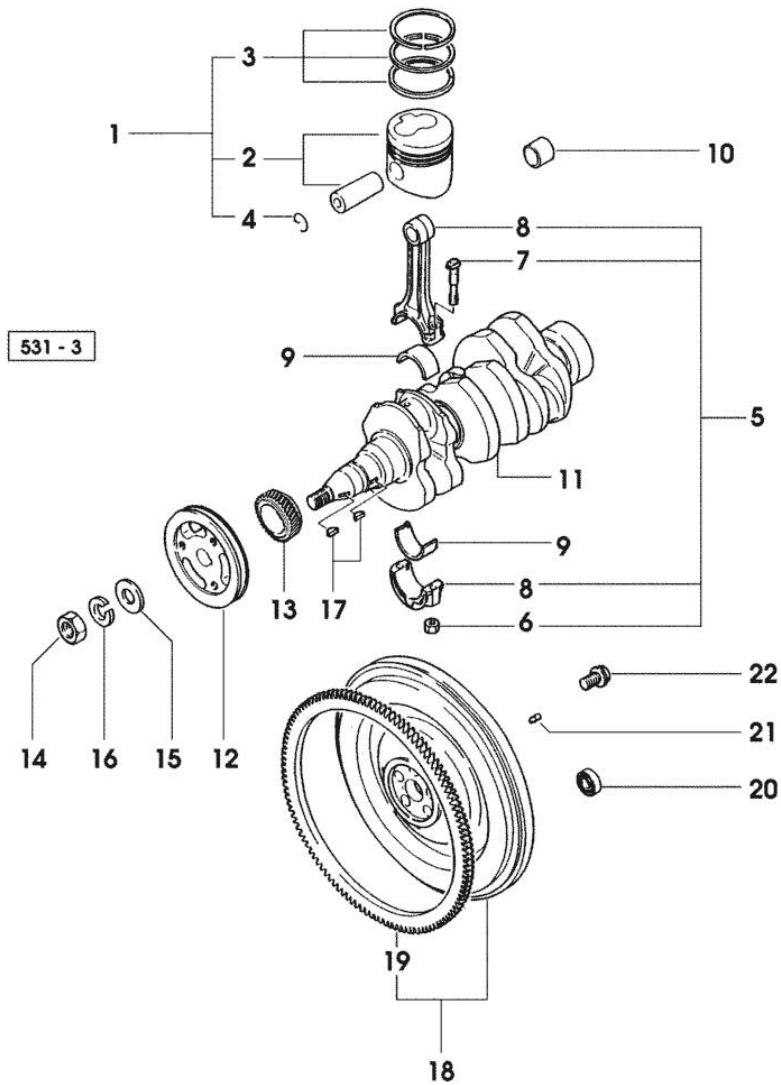

<https://www.ebooklibonline.com>

Hello dear friend!

Thank you very much for reading.

Enter the link into your browser.

The full manual is available for immediate download.

<https://www.ebooklibonline.com>

Section: ENGINE

CAMSHAFT

Fig.	P/n	QTY	Name
------	-----	-----	------

Notes:
[PRINCE 325 XV]

1	0.009.4757.0	1	shaft
2	0.009.4557.2	6	screw
3	0.009.4558.0	2	spring
4	0.009.4558.1	2	screw
5	0.009.4558.2	6	self-locking nut
6	0.009.4559.0	2	ring
7	0.009.4559.1	3	support
8	0.009.4559.2	6	rocker arm
9	0.009.4560.0	2	washer
10	0.009.4560.1	3	inlet valve Ø mm 6.5
11	0.009.4560.2	3	exhaust valve Ø mm 6.5
12	0.009.4561.0	6	spring
13	0.009.4561.1	6	cup
14	0.009.4561.2	12	stop
15	0.009.4562.0	6	gasket
16	0.009.4562.1	2	screw
17	0.009.4562.2	6	tappets
18	0.009.4563.0	6	rod
19	0.009.4563.1	1	screw
20	0.009.4563.2	2	washer
21	0.009.4757.1	1	camshaft
22	0.009.4564.1	1	gear
23	0.009.4555.1	1	key
24	0.009.4564.2	1	gear
25	0.009.4565.0	2	special bearing
26	0.008.6956.4	1	oil pump
27	0.009.4757.2	1	injection pump shaft
28	0.009.4566.0	1	washer
29	0.009.4566.1	1	gear
30	0.009.4566.2	1	gear
31	0.009.4567.0	1	special bearing
32	0.009.4567.1	1	screw
33	0.009.4567.2	1	stick

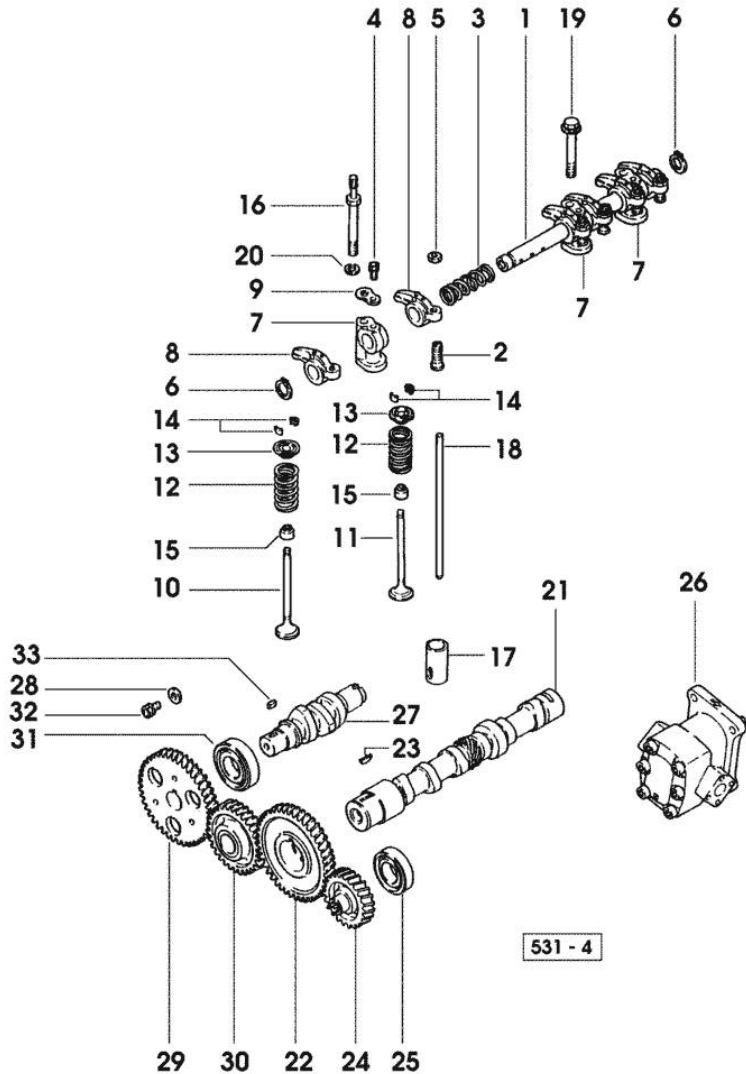

Section: ENGINE
CYLINDER HEAD

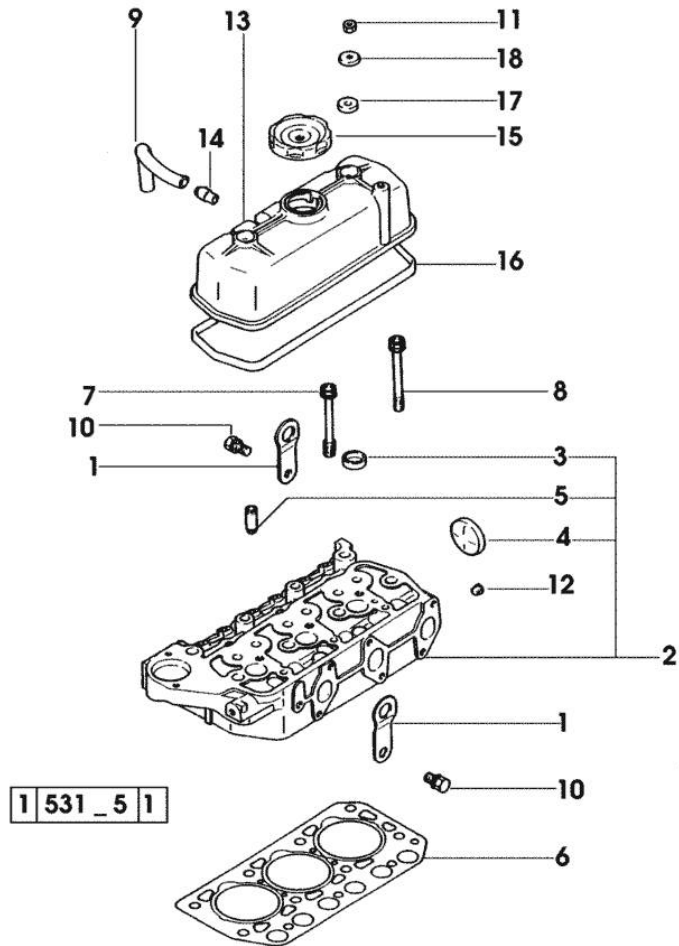

Fig.	P/n	QTY	Name
------	-----	-----	------

Notes:
[PRINCE 325 XV]

1	0.009.4541.2	2	bracket
2	0.009.4759.0	1	engine head
3	0.009.4527.0	3	plug
4	0.009.4527.1	1	plug
5	0.009.4542.1	6	valve guide
6	0.009.4758.0		head gasket mm 1.40
6	0.009.4758.1		head gasket mm 1.53
6	0.009.4758.2		head gasket mm 1.60
7	0.009.4543.2	3	screw
8	0.009.4759.1	8	screw
9	0.009.4547.2	1	tube
10	0.009.4544.2	2	screw
11	0.009.4539.0	2	nut
12	0.009.4545.1	1	plug
13	0.009.4759.4/10	1	complete cover
14	0.009.4546.0	1	tube
15	0.009.4548.0	1	plug
16	0.009.4760.0	1	gasket
17	0.009.4547.0	2	gasket
18	0.009.4547.1	2	washer

Section: ENGINE
LUBRICATION

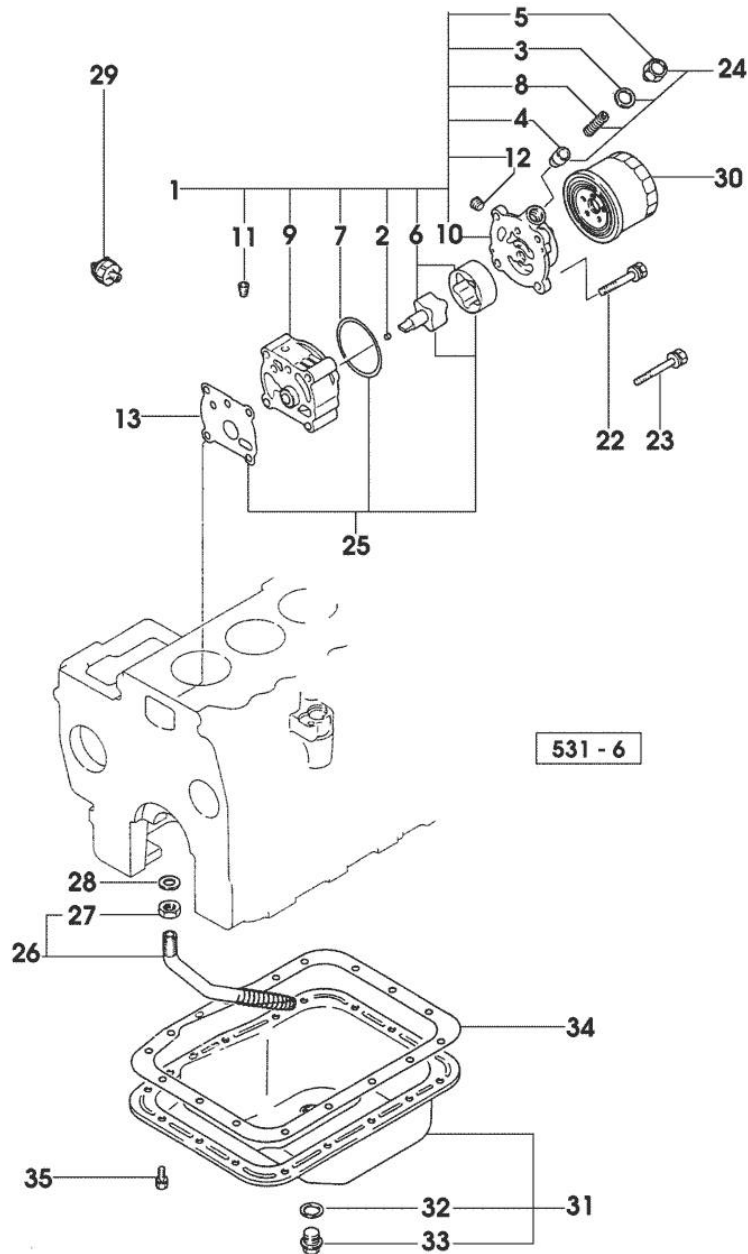

Fig.	P/n	QTY	Name
------	-----	-----	------

Notes:
[PRINCE 325 XV]

1	0.009.4626.4	1	oil pump
2	0.009.4626.0	2	pin
3	0.009.4540.1	1	gasket
4	0.009.4626.1	1	pin seat
5	0.009.4627.0	1	plug
6	0.009.4627.3	1	impeller
7	0.009.4760.1	1	special oil seal
8	0.009.4628.0	1	spring
9	0.000.0000.1		cannot be supplied
10	0.009.4628.2	1	cover
11	0.009.4545.1	1	plug
12	0.009.4526.0	1	plug
13	0.009.4629.1	1	gasket
22	0.009.4632.1	3	screw
23	0.009.4632.2	1	screw
24	0.009.4633.6	1	valve
25	0.009.4633.4	1	oil pump
26	0.009.4633.3	1	level indicator
27	0.009.4634.0	1	self-locking nut
28	0.009.4634.1	1	gasket
29	0.009.4634.2	1	switch
30	0.009.4794.1	1	oil filter element
31	0.009.4540.4	1	oil sump - X 35HP
31	0.009.4760.2	1	oil sump - X 25HP
32	0.009.4540.1	1	gasket
33	0.009.4541.0	1	plug
34	0.009.4541.1	1	gasket Ø mm 38 - X 35HP
34	0.009.4761.0	1	gasket - X 25HP
35	0.009.4530.1	17	screw - X 25HP

Section: ENGINE

FUEL SUPPLY SYSTEM

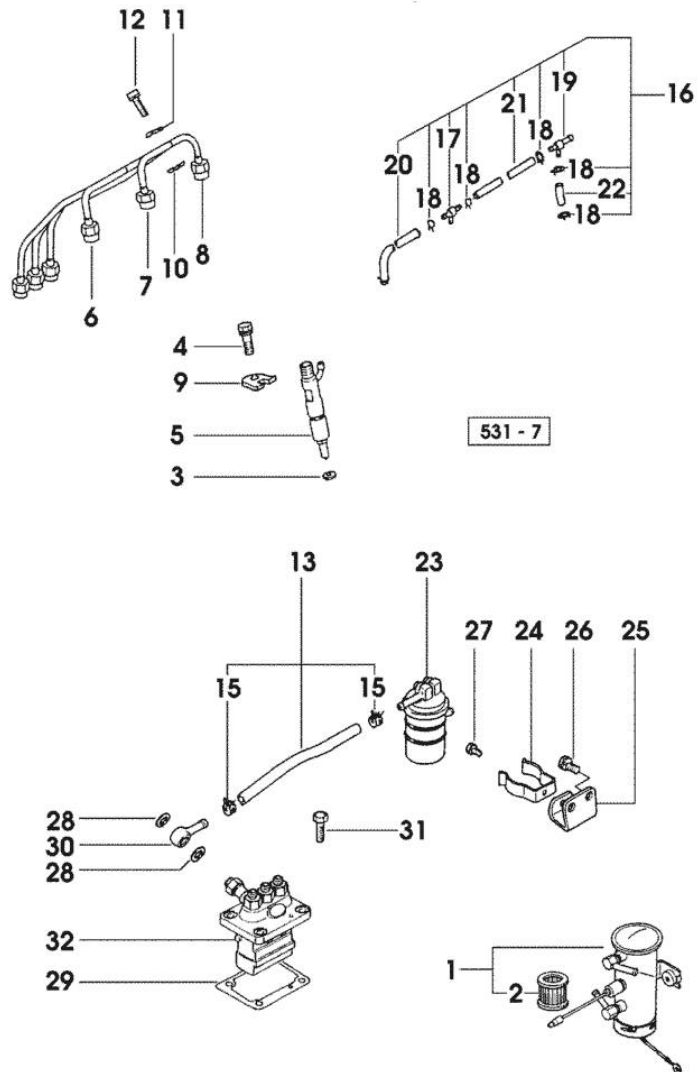

Notes:
[PRINCE 325 XV]

Fig.	P/n	QTY	Name
1	0.008.6957.4	1	feed pump ☞ 0.008.6957.4
2	0.009.4683.0	1	fuel filter element
3	0.009.4568.1	3	gasket
4	0.009.4568.2	3	screw
5	0.009.4770.4	4	injector assembly ☞ 01.00.79
6	0.009.4569.1	1	tube
7	0.009.4569.2	1	tube
8	0.009.4570.0	1	tube
9	0.009.4568.0	3	support
10	0.009.4570.2	2	clamp
11	0.009.4571.0	2	clamp
12	0.009.4571.1	2	screw
13	0.009.4761.2	1	tube
15	0.009.4572.1	2	clamp
16	0.009.4762.0	1	tube
17	0.009.4573.0	1	joint
18	0.009.4573.1	5	clamp
19	0.009.4573.2	1	joint
20	0.009.4574.0	1	rubber tube
21	0.009.4574.1	1	rubber tube
22	0.009.4574.2	2	rubber tube
23	0.009.4575.0	1	fuel filter element
24	0.009.4575.1	1	clamp
25	0.009.4575.2	1	support
26	0.009.4530.1	2	screw
27	0.009.4576.0	1	screw
28	0.009.4762.1	2	gasket
29	0.009.4763.0	1	shim mm 0.20
29	0.009.4763.1	1	shim mm 0.3
29	0.009.4763.2	1	shim mm 0.4
29	0.009.4764.0	1	shim mm 0.50
29	0.009.4764.1	1	shim mm 0.6
29	0.009.4764.2	1	shim mm 0.7
29	0.009.4765.0	1	shim mm 0.8
29	0.009.4765.1	1	shim mm 0.9
29	0.009.4765.2	1	shim mm 1.0
30	0.009.4774.1	1	pipe fitting
31	0.009.4580.0	4	screw
32	0.009.4766.4	1	injector pump

Section: ENGINE
FUEL SUPPLY SYSTEM

Fig.	P/n	QTY	Name
------	-----	-----	------

01.00.64

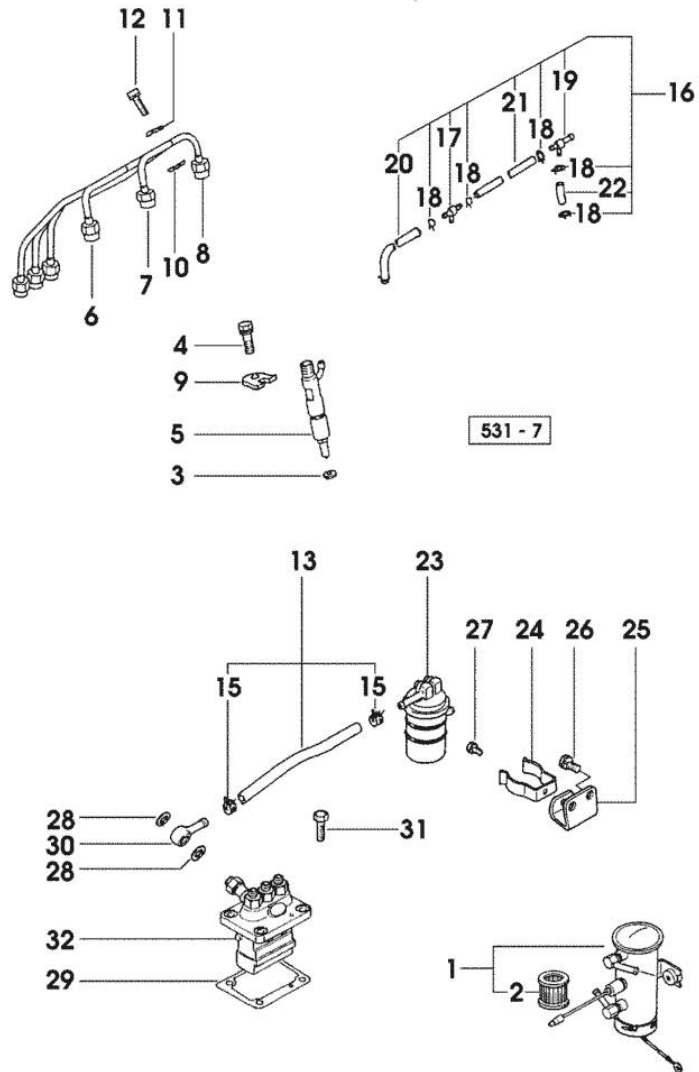

Section: ENGINE

INJECTION PUMP PARTS

Fig.	P/n	QTY	Name
------	-----	-----	------

Notes:
[PRINCE 325 XV]

1	0.009.4766.4	1	injector pump
2	0.009.4581.0	3	pipe fitting
3	0.009.4766.1	3	spring
4	0.009.4581.2	3	gasket
5	0.009.4767.0	3	valve
6	0.009.4582.1	3	pumping element
7	0.009.4582.2	3	sleeve
8	0.009.4583.0	3	valve seat
9	0.009.4583.1	3	spring
10	0.009.4583.2	3	tappets
11	0.009.4767.1	3	ratchet
12	0.009.4584.1	3	valve seat
13	0.009.4584.2	3	ring
14	0.009.4585.0	3	pin
15	0.009.4767.2	1	small plate
16	0.009.4585.2	2	small plate
17	0.009.4586.0	2	screw
18	0.009.4586.1	1	screw
19	0.009.4768.0	1	pipe fitting
20	0.009.4587.0	1	washer
21	0.009.4587.1	3	shim mm 0.60
21	0.009.4587.2	3	shim mm 0.20
21	0.009.4588.0	3	shim mm 0.30
21	0.009.4588.1	3	shim mm 0.40
21	0.009.4588.2	3	shim mm 0.5
21	0.009.4589.0	3	shim mm 0.25
21	0.009.4589.1	3	shim mm 0.35
21	0.009.4589.2	3	shim mm 0.45
21	0.009.4590.0	3	shim mm 0.55
21	0.009.4590.1	3	shim mm 0.65
22	0.009.4590.2	1	spring
23	0.009.4591.0	1	ring
24	0.009.4591.1	1	ring
25	0.009.4768.1	1	spring
26	0.009.4592.0	1	plate 6, d128
26	0.009.4592.1	1	plate 7
26	0.009.4592.2	1	plate 8
26	0.009.4593.0	1	plate 9
26	0.009.4593.1	1	plate 10
26	0.009.4593.2	1	plate 11
26	0.009.4594.0	1	plate 12

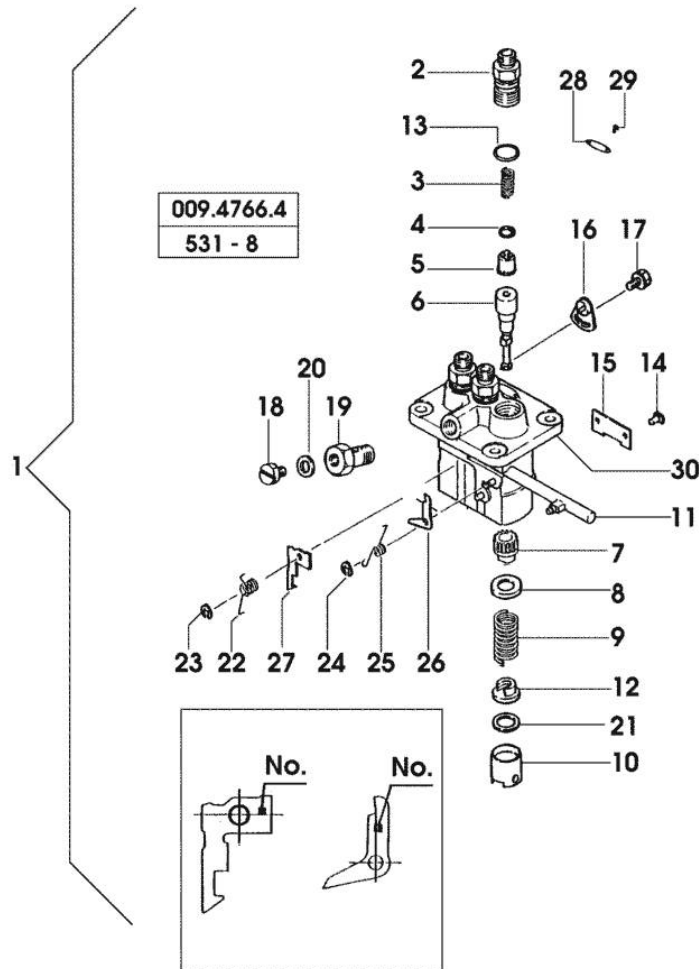



Suggest:

For more complete manuals. Please go to the home page.

<https://www.ebooklibonline.com>

If the above button click is invalid. Please download this document first, and then click the above link to download the complete manual.

Thank you so much for reading

Section: ENGINE

INJECTION PUMP PARTS

Fig.	P/n	QTY	Name
27	0.009.4594.1	1	plate 66
27	0.009.4594.2	1	plate 67
27	0.009.4595.0	1	plate 68
27	0.009.4595.1	1	plate 69
27	0.009.4595.2	1	plate 70
27	0.009.4596.0	1	plate 71
27	0.009.4596.1	1	plate 72
27	0.009.4596.2	1	plate 73
27	0.009.4597.0	1	plate 74
27	0.009.4597.1	1	plate 75
27	0.009.4597.2	1	plate 76
27	0.009.4768.2	1	plate 62
27	0.009.4769.0	1	plate 63
27	0.009.4769.1	1	plate 64
27	0.009.4769.2	1	plate 65
28	0.009.4769.3	1	plate
29	0.009.4599.2	2	rivet
30	0.000.0000.1		cannot be supplied

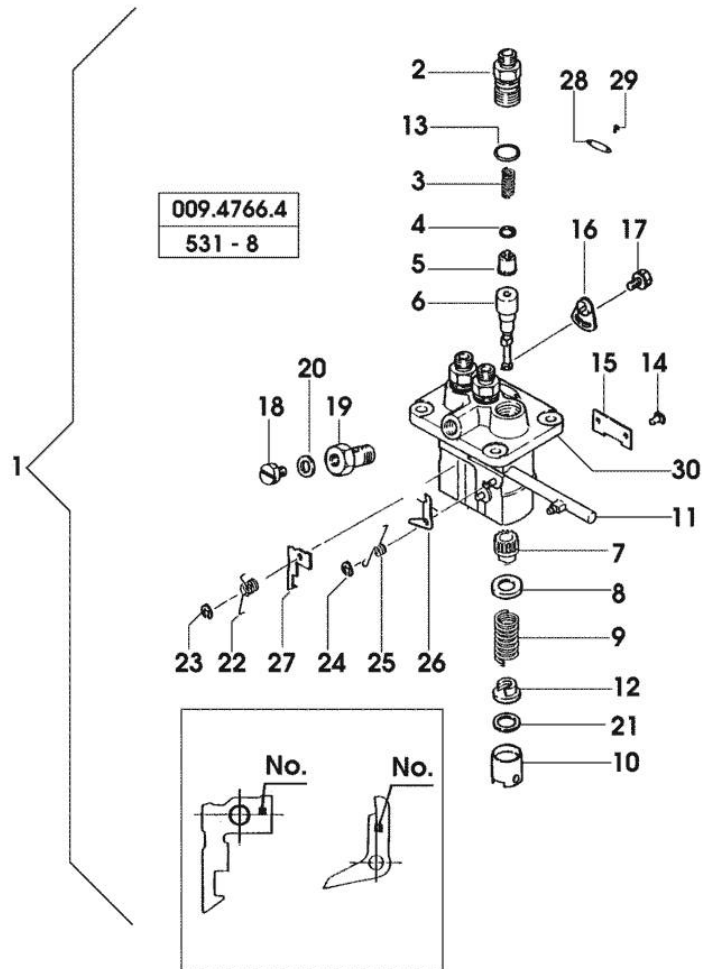

INJECTOR NOZZLE HOLDER COMPONENTS

Fig.	P/n	QTY	Name
------	-----	-----	------

Notes:
[PRINCE 325 XV]

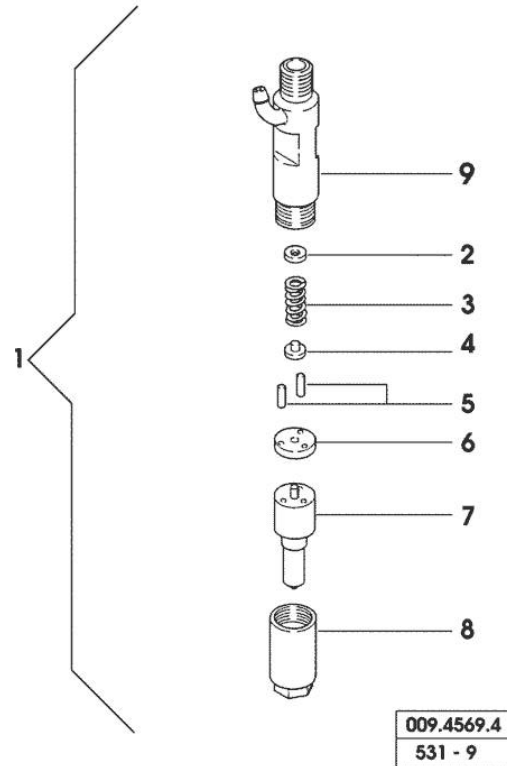

1	0.009.4770.4	1	injector assembly
2	0.009.4600.1		washer mm 1.00
2	0.009.4600.2		washer mm 1.05
2	0.009.4601.0		washer mm 1.10
2	0.009.4601.1		washer mm 1.15
2	0.009.4601.2		washer mm 1.20
2	0.009.4602.0		washer mm 1.25
2	0.009.4602.1		washer mm 1.30
2	0.009.4602.2		washer mm 1.35
2	0.009.4603.0		washer mm 1.40
2	0.009.4603.1		washer mm 1.45
2	0.009.4603.2		washer mm 1.50
2	0.009.4604.0		washer mm 1.55
2	0.009.4604.1		washer mm 1.60
2	0.009.4604.2		washer mm 1.65
2	0.009.4605.0		washer mm 1.70
2	0.009.4605.1		washer mm 1.75
2	0.009.4605.2		washer mm 1.80
2	0.009.4606.0		washer mm 1.85
2	0.009.4606.1		washer mm 1.90
2	0.009.4606.2		washer mm 1.95
2	0.009.4607.0		washer mm 2.00
2	0.009.4607.1		washer mm 2.05
2	0.009.4607.2		washer mm 2.10
2	0.009.4608.0		washer mm 2.15
2	0.009.4608.1		washer mm 1.275
2	0.009.4608.2		washer mm 1.325
2	0.009.4609.0		washer mm 1.375
2	0.009.4609.1		washer mm 1.425
2	0.009.4609.2		washer mm 1.475
2	0.009.4610.0		washer mm 1.525
2	0.009.4610.1		washer mm 1.575
2	0.009.4610.2		washer mm 1.625
2	0.009.4611.0		washer mm 1.675
2	0.009.4611.1		washer mm 1.725
2	0.009.4611.2		washer mm 1.775
2	0.009.4612.0		washer mm 0.95
3	0.009.4612.1	1	spring
4	0.009.4612.2	1	pin
5	0.009.4613.0	2	pin
6	0.009.4613.1	1	gasket

<https://www.ebooklibonline.com>

Hello dear friend!

Thank you very much for reading.

Enter the link into your browser.

The full manual is available for immediate download.

<https://www.ebooklibonline.com>