

ENGINE

Fig.	P/n	QTY	Name
------	-----	-----	------

Notes:

[PRINCE 45 -> 15001 4WD B]

101	6.N8700.01.0	1	new engine <=50 kw
-----	--------------	---	--------------------

☞ 6.N8700.01.0

☞ 6.N8700.01.0

☞ 6.N8700.01.0

☞ 6.N8700.01.0

☞ 6.N8700.01.0

☞ 6.N8700.01.0

☞ 6.N8700.01.0

☞ 6.N8700.01.0

☞ 6.N8700.01.0

☞ 6.N8700.01.0

☞ 6.N8700.01.0

☞ 6.N8700.01.0

☞ 6.N8700.01.0

☞ 6.N8700.01.0

☞ 6.N8700.01.0

☞ 6.N8700.01.0

☞ 6.N8700.01.0

☞ 6.N8700.01.0

☞ 6.N8700.01.0

☞ 6.N8700.01.0

☞ 6.N8700.01.0

☞ 6.N8700.01.0

☞ 6.N8700.01.0

☞ 6.N8700.01.0

☞ 6.N8700.01.0

☞ 6.N8700.01.0

☞ 6.N8700.01.0

☞ 6.N8700.01.0

☞ 6.N8700.01.0

☞ 6.N8700.01.0

☞ 6.N8700.01.0

☞ 6.N8700.01.0

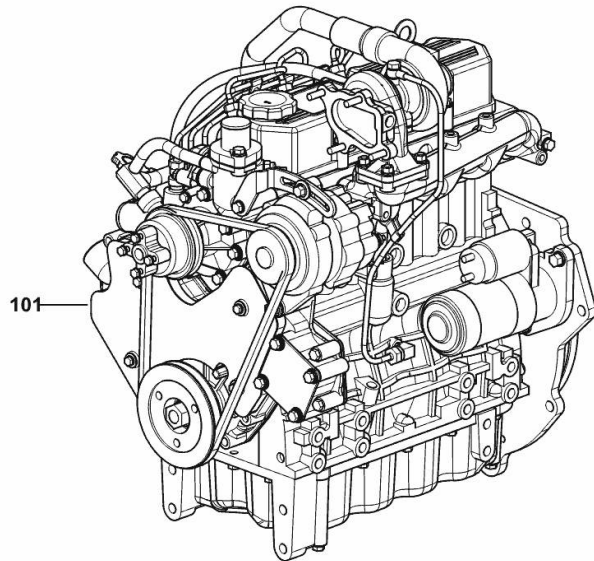

W9_A5281_02_0-B-001

Section: B0 - ENGINE
CYLINDER HEAD

Fig.	P/n	QTY	Name
1	0.010.3986.0	1	engine head
1.2	0.000.0000.1		cannot be supplied
1.2.1	0.010.2634.1	1	plug
1.2.2	0.010.2636.1	7	plug
1.2.3	0.000.0000.1		cannot be supplied
1.2.4	0.000.0000.1		cannot be supplied
1.2.5	0.010.2634.2	4	valve guide
1.2.6	0.010.2635.0	4	valve guide
1.2.7	0.000.0000.1		cannot be supplied
1.2.8	0.010.2636.2	4	special bushing
1.3	0.009.4545.1	1	plug
4	0.010.2633.1	14	screw
5	0.010.2635.2	1	gasket
6	0.009.4541.2	2	bracket
7	0.010.2633.0	2	screw

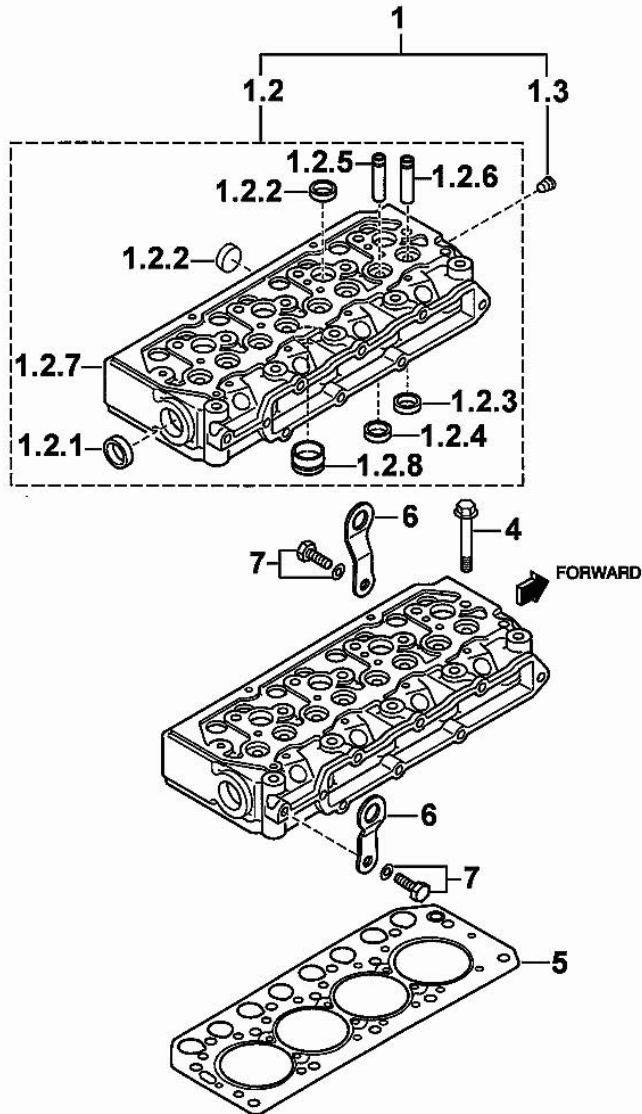

MIT_H36_002-A-001

01011-001E 45CV

Section: B0 - ENGINE
CYLINDER HEAD

Fig.	P/n	QTY	Name
1	0.010.2637.2	4	inlet valve Ø mm 6.5
2	0.010.2638.0	4	exhaust valve Ø mm 6.5
3	0.010.2638.1	8	spring
4	0.000.0000.1	8	cannot be supplied
5	0.009.4561.2	16	stop
6	0.009.4562.0	8	gasket
7	0.010.2639.0	8	cap
8	0.000.0000.1	1	cannot be supplied
8.1	0.010.2640.1	1	screw
8.2	0.009.4559.0	2	ring
8.3	0.010.3949.0	8	rocker arm
8.3.4	0.010.2641.0	8	nut
8.3.5	0.000.0000.1		cannot be supplied
8.3.6	0.010.3949.1	8	register
8.7	0.010.2644.1	1	shaft
8.7.8	0.010.2643.0	2	plug
8.7.9	0.000.0000.1		cannot be supplied
8.10	0.010.2642.0	1	support
8.11	0.010.2642.1	3	support
8.12	0.010.2643.1	3	spring
8.13	0.010.2643.2	4	screw
9	0.010.2644.0	1	camshaft
10	0.009.4567.0	1	special bearing
11	0.009.4566.0	1	washer
12	0.009.4567.2	1	stick
13	0.010.2639.1	1	screw

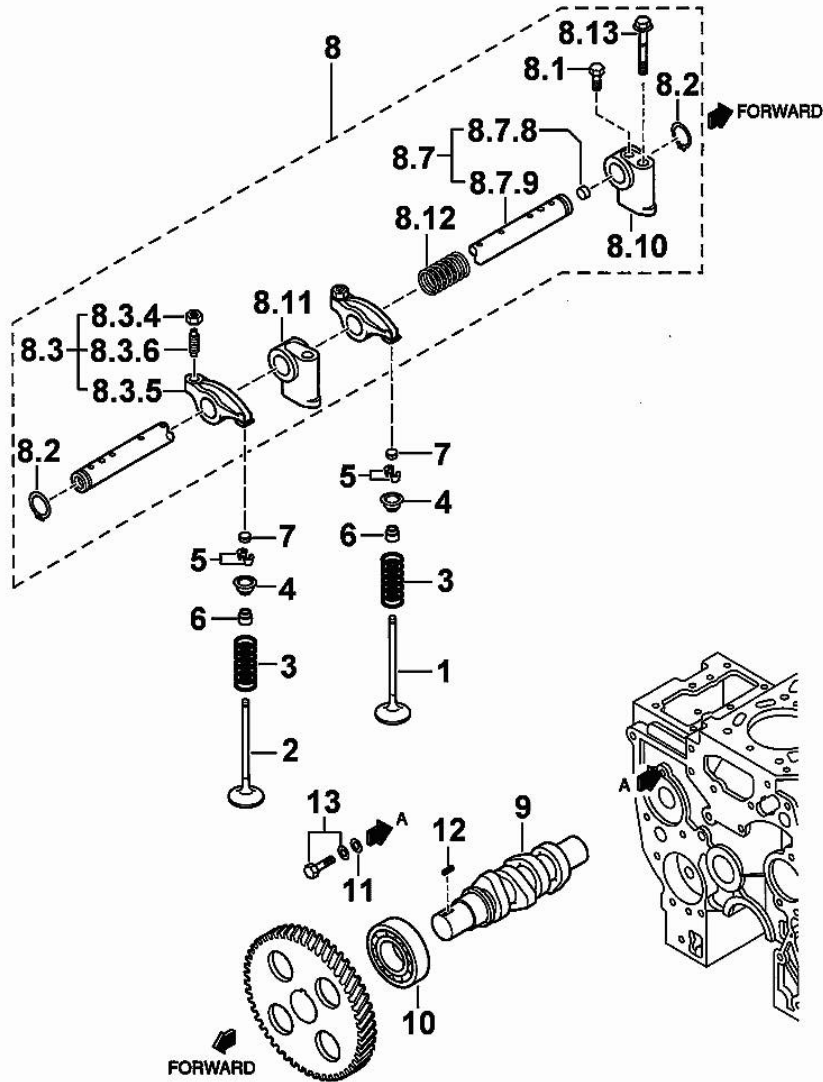

MIT_H36_004-A-001

01021-013E

<https://www.ebooklibonline.com>

Hello dear friend!

Thank you very much for reading.

Enter the link into your browser.

The full manual is available for immediate download.

<https://www.ebooklibonline.com>

Section: B0 - ENGINE
CYLINDER HEAD

Fig.	P/n	QTY	Name
1	0.010.2647.1	1	cover
1.1	0.000.0000.1		cannot be supplied
1.2	0.000.0000.1		cannot be supplied
2	0.010.2647.2	1	gasket
3	0.010.2645.2	5	screw
4	0.009.4548.0	1	plug
5	0.009.4781.2	1	tube
6	0.010.2206.0	1	clamp

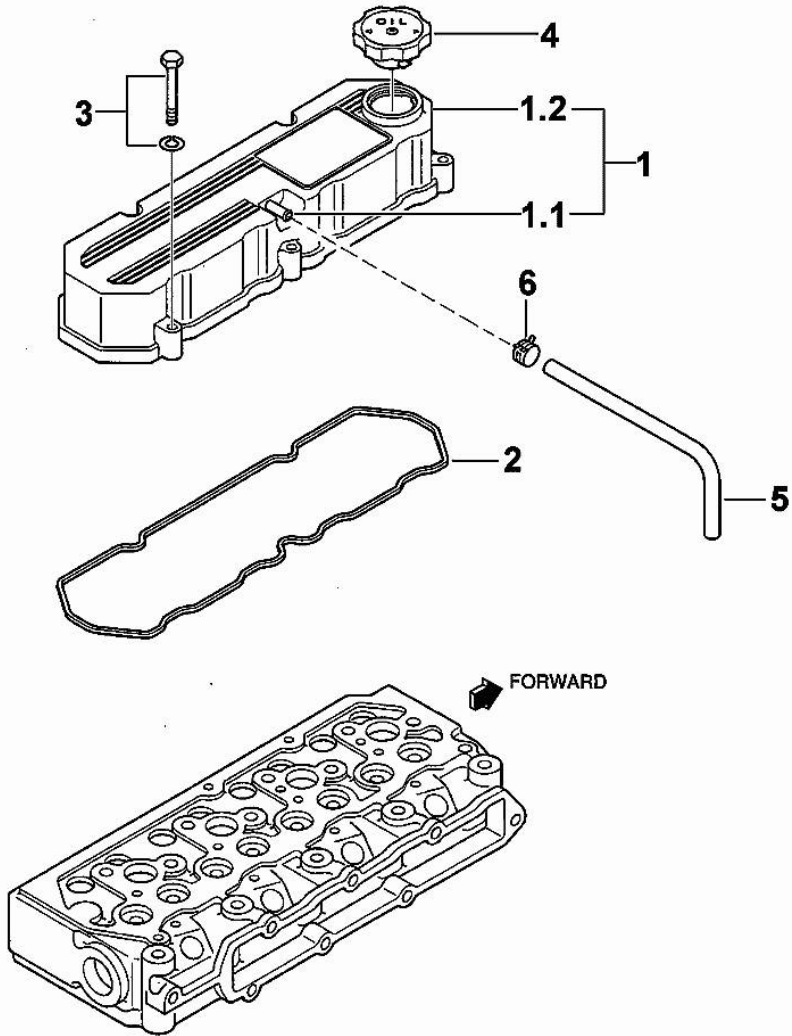

MIT_H36_006-A-001

01031-015E

CAMSHAFT

Fig.	P/n	QTY	Name
1	0.010.3949.2	1	camshaft
2	0.009.4555.1	1	key
3	0.010.3950.0	1	small plate
4	0.010.2639.1	2	screw
5	0.010.3950.1	8	tappets
6	0.010.2646.2	8	rod

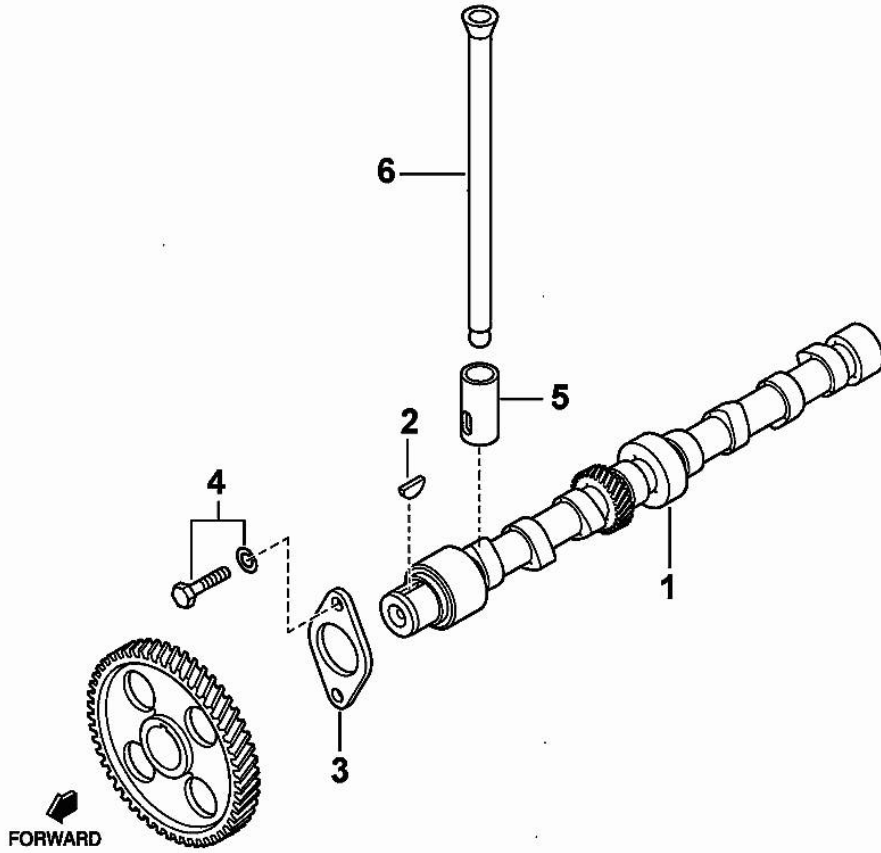

01031-016E

MIT_H36_007-A-001

CRANKCASE

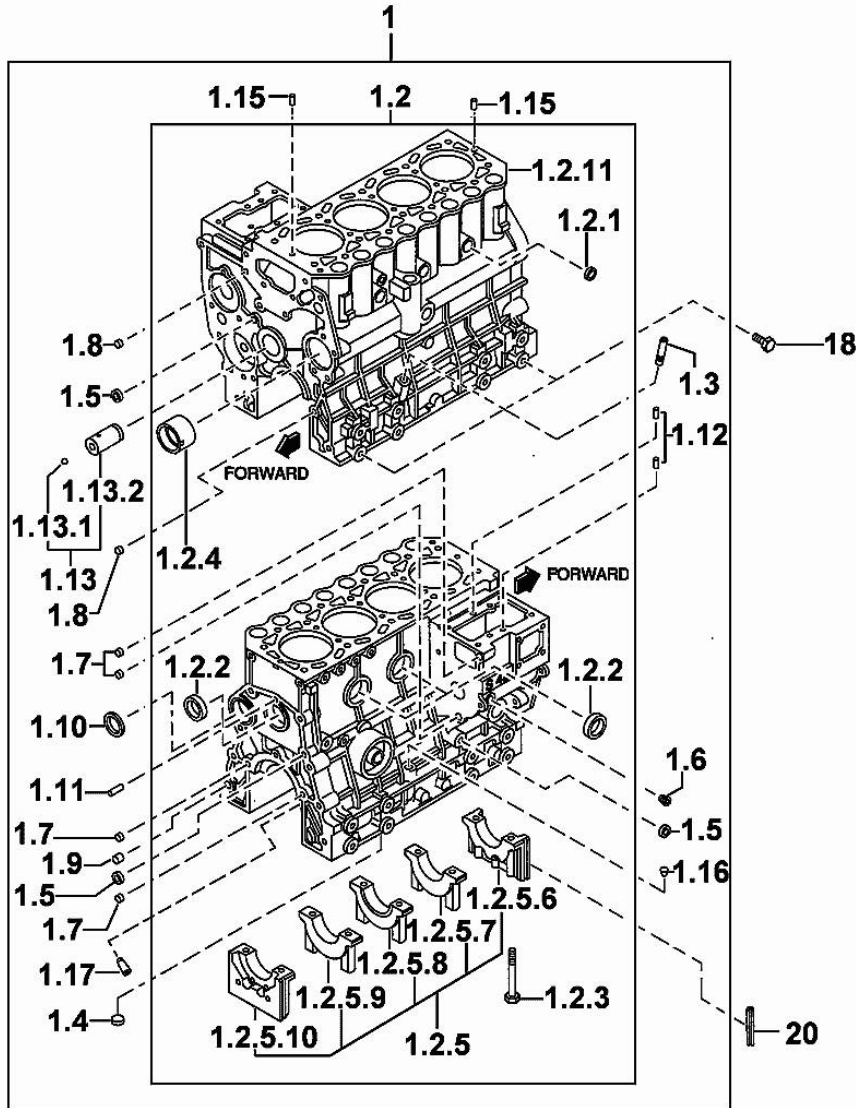

Fig.	P/n	QTY	Name
1	0.010.3961.1	1	crankcase
1.2	0.000.0000.1		cannot be supplied
1.2.1	0.010.2652.1	3	special bushing
1.2.2	0.010.2652.2	3	special bushing
1.2.3	0.010.2653.0	10	screw
1.2.4	0.010.2653.1	1	special bushing
1.2.5	0.000.0000.1		cannot be supplied
1.2.5.6	0.000.0000.1		cannot be supplied
1.2.5.7	0.000.0000.1		cannot be supplied
1.2.5.8	0.000.0000.1		cannot be supplied
1.2.5.9	0.000.0000.1		cannot be supplied
1.2.5.10	0.000.0000.1		cannot be supplied
1.2.11	0.000.0000.1		cannot be supplied
1.3	0.009.4523.2	1	guide
1.4	0.010.2649.0	1	plug
1.5	0.010.2649.1	3	special bushing
1.6	0.009.4545.1	1	plug
1.7	0.009.4524.2	4	special bushing
1.8	0.009.4525.1	2	special bushing
1.9	0.009.4525.2	1	special bushing
1.10	0.009.4524.1	1	expansion plug
1.11	0.010.3951.0	1	pin
1.12	0.009.4523.0	2	pin
1.13	0.010.2650.0	1	pin
1.13.1	0.010.2650.1	1	ball
1.13.2	0.000.0000.1		cannot be supplied
1.15	0.010.2651.0	2	pin
1.16	0.010.2651.1	1	plug
1.17	0.010.3961.2	4	sprayers
18	0.010.2648.1	4	screw
20	0.010.2651.2	4	gasket

MIT_H36_009-A-001

01041-019E 45CV

Section: B0 - ENGINE

MAIN BEARINGS

Fig.	P/n	QTY	Name
1	0.010.2656.2	1	main half bushing STANDARD
2	0.010.2657.0	1	main half bushing - mm 0.25
3	0.010.2657.1	1	main half bushing - mm 0.50
4	0.010.2657.2	1	main half bushing - mm 0.75

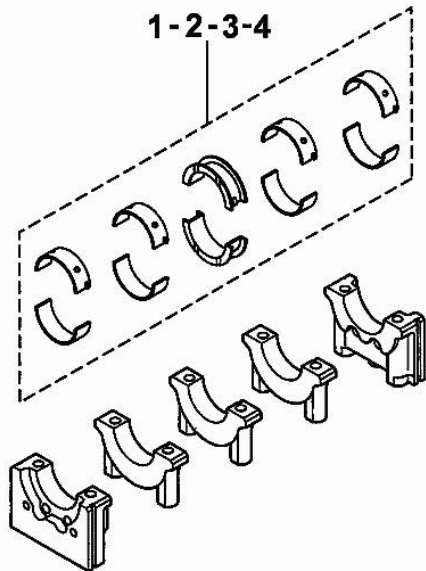
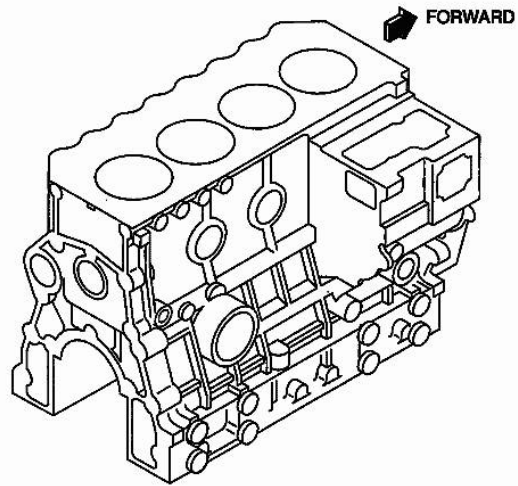

MIT_H36_012-A-001

0104B1-001E

TIMING CASE

Fig.	P/n	QTY	Name
1	0.010.2658.0	1	plate
2	0.010.2658.1	1	gasket
3	0.010.2639.1	10	screw
4	0.010.3951.1	1	flange
5	0.010.2659.0	1	gasket
6	0.010.2659.1	8	screw
7	0.009.4537.0	1	gasket
8	0.010.3951.2	1	plug
9	0.010.2660.0	1	flange
10	0.010.2660.1	1	gasket
11	0.009.4756.0	2	cover
12	0.010.3952.0	2	gasket
13	0.010.2661.0	1	screw
14	0.010.2661.1	2	nut
15	0.010.3952.1	1	screw
16	0.010.3952.2	2	screw
17	0.009.4539.2	2	spring washer
18	0.010.3953.0	1	cover
19	0.010.2662.2	4	screw
20	0.010.2663.0	4	washer

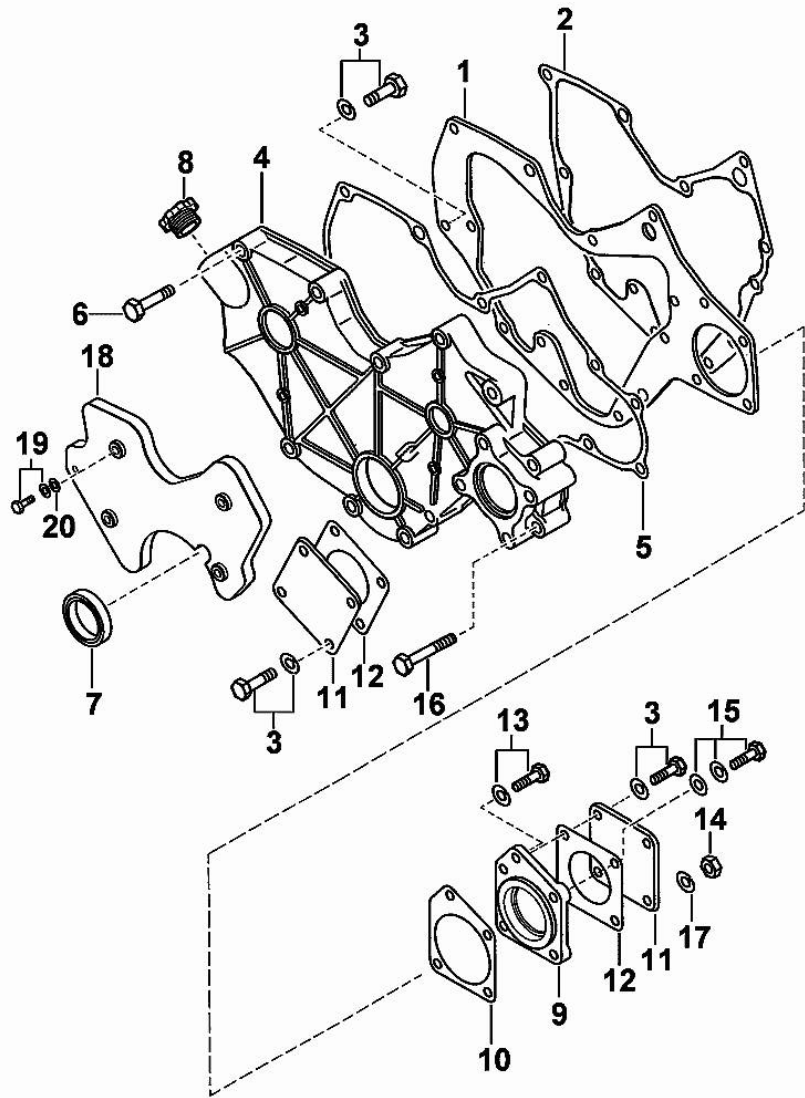

MIT_H36_013-A-001

01051-018

FLYWHEEL HOUSING

Fig.	P/n	QTY	Name
1	0.010.2654.2	1	flange
2	0.010.2655.0	1	gasket
3	0.010.2655.1	1	special oil seal
4	0.010.2655.2	5	screw
5	0.010.3953.1	1	flange
6	0.009.4532.2	1	pin
7	0.010.3953.2	10	screw

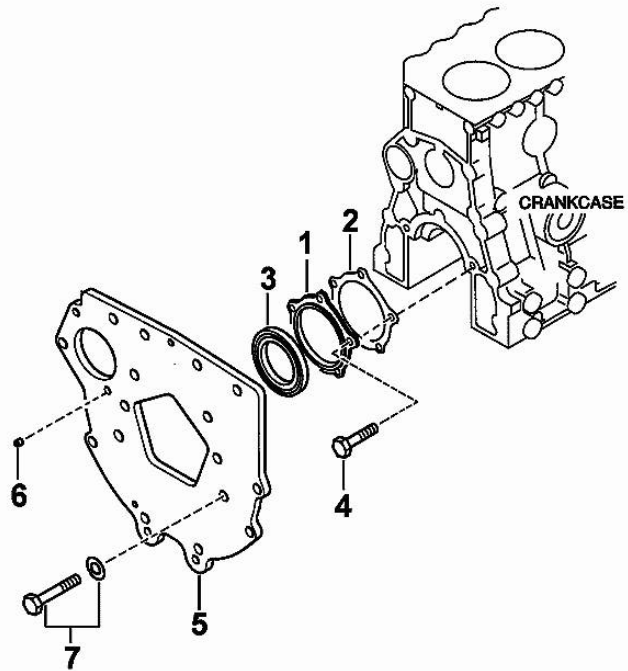

MIT_H36_014-A-001

01061-019E

OIL PAN

Fig.	P/n	QTY	Name
1	0.010.3954.0	1	oil sump
1.1	0.010.2664.0	1	plug
1.2	0.010.2663.2	1	gasket
1.3	0.000.0000.1		cannot be supplied
2	0.010.3954.1	12	screw
3	0.010.2664.2	1	screw
4	0.010.2665.0	4	screw
5	0.010.2665.1	5	washer
6	0.010.2687.1	1	dipstick

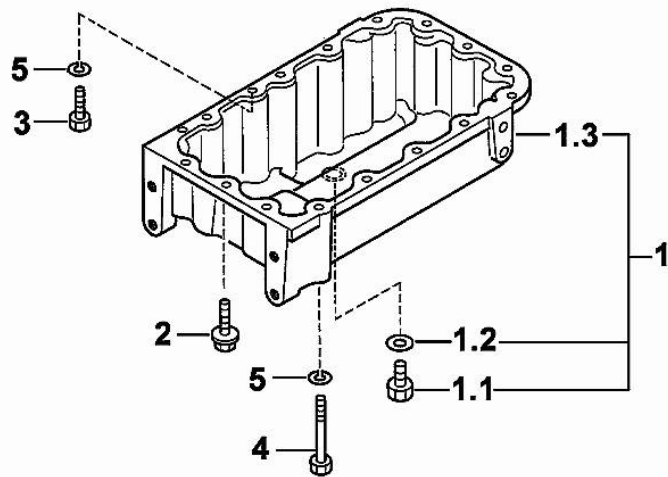
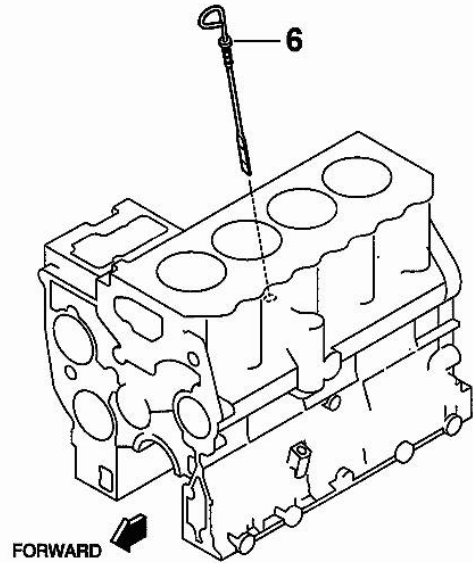

MIT_H36_015-A-001

01071-038E

PISTON - CONNECTING ROD

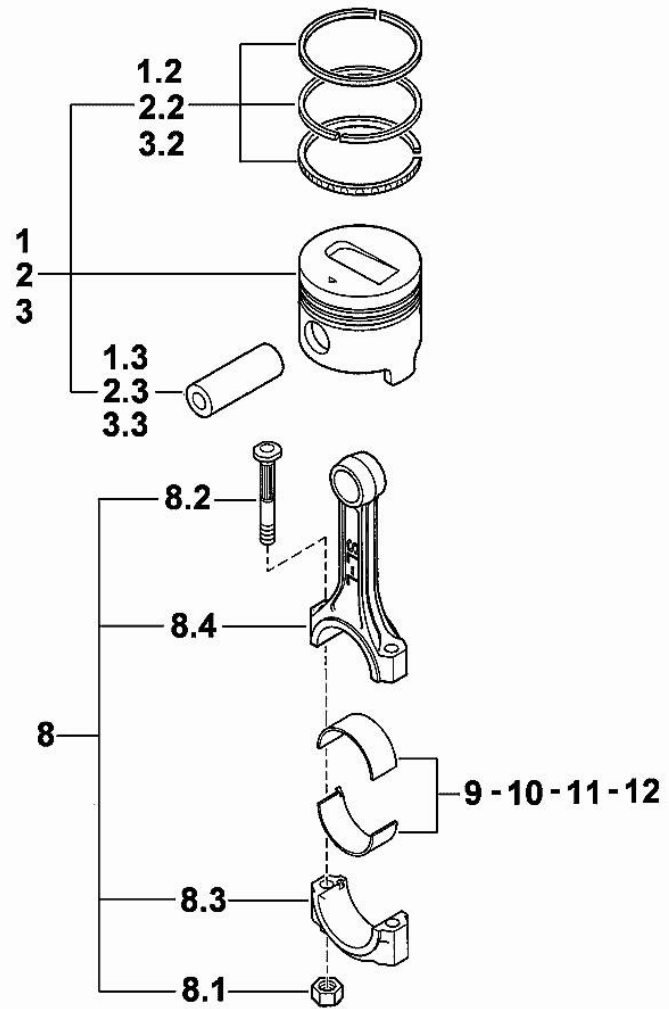

Fig.	P/n	QTY	Name
1	0.009.0060.6	4	complete piston STANDARD
1.2	0.008.0052.6	4	piston ring set STANDARD
1.3	0.010.2668.0	4	piston pin
2	0.009.0061.6	4	complete piston + mm 0.25
2.2	0.008.0053.6	4	piston ring set + mm 0.25
2.3	0.010.2668.0	4	piston pin
3	0.009.0062.6	4	complete piston + mm 0.50
3.2	0.008.0054.6	4	piston ring set + mm 0.50
3.3	0.010.2668.0	4	piston pin
8	0.010.2671.2	4	engine connecting rod
8.1	0.009.4783.0	8	nut
8.2	0.010.2668.2	8	screw
8.3	0.000.0000.1		cannot be supplied
8.4	0.000.0000.1		cannot be supplied
9	0.009.4782.1	4	con.rod half bushing STANDARD
10	0.010.2669.0	4	con.rod half bushing - mm 0.25
11	0.010.2669.1	4	con.rod half bushing - mm 0.50
12	0.010.2669.2	4	con.rod half bushing - mm 0.75

MIT_H36_017-A-001

0108A1-002 45CV

CRANKSHAFT - FLYWHEEL

Fig.	P/n	QTY	Name
1	0.010.2672.0	1	crankshaft
2	0.009.4555.1	2	key
3	0.009.4554.2	1	flat washer
4	0.009.4555.0	1	spring washer
5	0.009.4554.1	1	nut
6	0.010.2672.2	1	pulley
7	0.010.3954.2	1	flywheel
7.1	0.010.2671.0	1	crown wheel Z=110
7.2	0.000.0000.1		cannot be supplied
8	0.009.4557.0	4	screw
9	0.010.3955.0	1	gear Z = 28
10	0.009.4556.1	1	special bearing

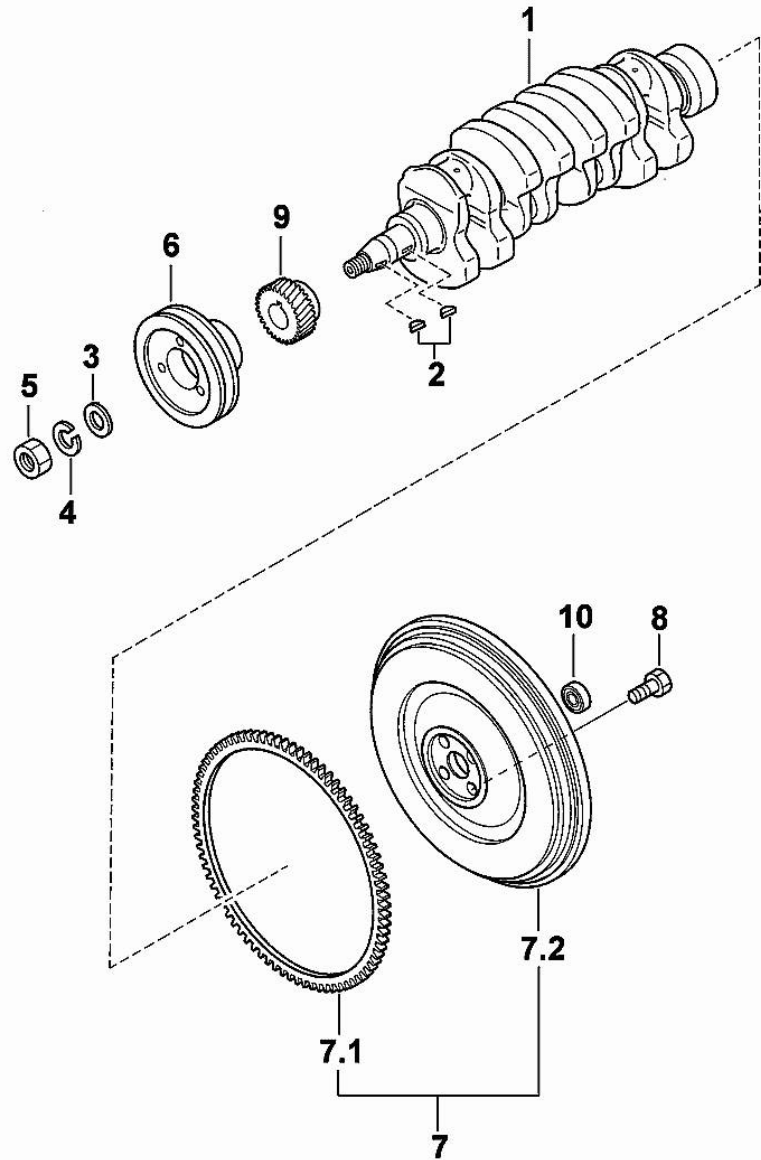

MIT_H36_019-A-001

0108B1-021

CAMSHAFT

Fig.	P/n	QTY	Name
1	0.010.3955.1	1	gear z=56
2	0.010.3955.2	1	gear z=56
3	0.010.3956.0	1	gear z=39
3.1	0.000.0000.1		cannot be supplied
3.2	0.000.0000.1		cannot be supplied

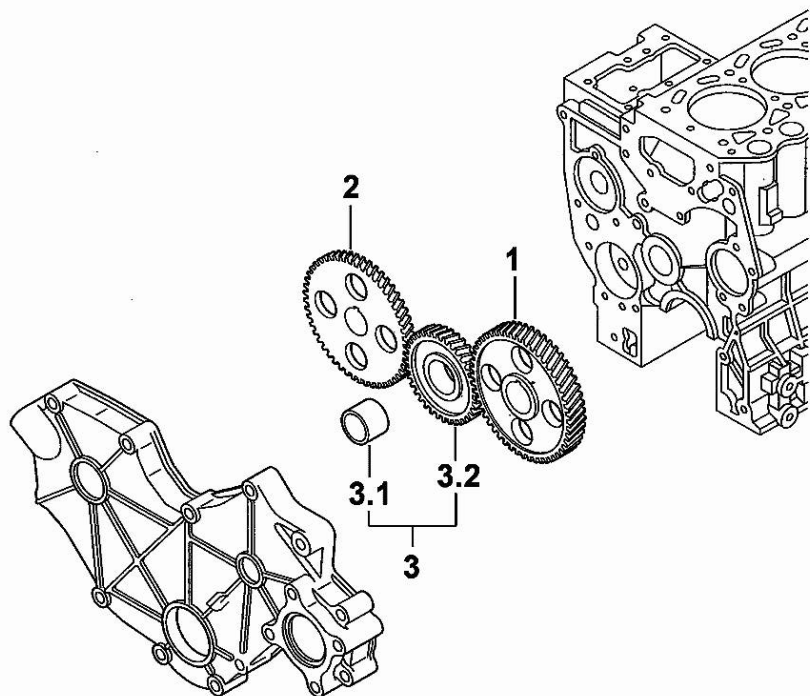

MIT_H36_021-A-001

01091-020E

INTAKE AND EXHAUST

Fig.	P/n	QTY	Name
1	0.010.2678.2	1	cover
2	0.010.2678.1	1	gasket
3	0.010.2676.2	1	gasket
4	0.010.2677.0	8	screw
5	0.010.2677.1	2	screw
6	0.010.3956.1	1	exhaust manifold
7	0.010.2680.1	1	gasket
8	0.010.3956.2	6	screw
9	0.010.3957.0	2	screw
10	0.010.2679.0	1	sleeve
11	0.010.3964.2	2	clamp
12	0.010.3965.0	1	small plate
13	0.010.2681.0	1	turbo charger
14	0.009.4796.1	3	stud bolt
15	0.009.4798.0	1	gasket
16	0.009.4799.2	3	nut
17	0.009.4842.0	3	flat washer
18	0.009.4842.1	4	stud bolt

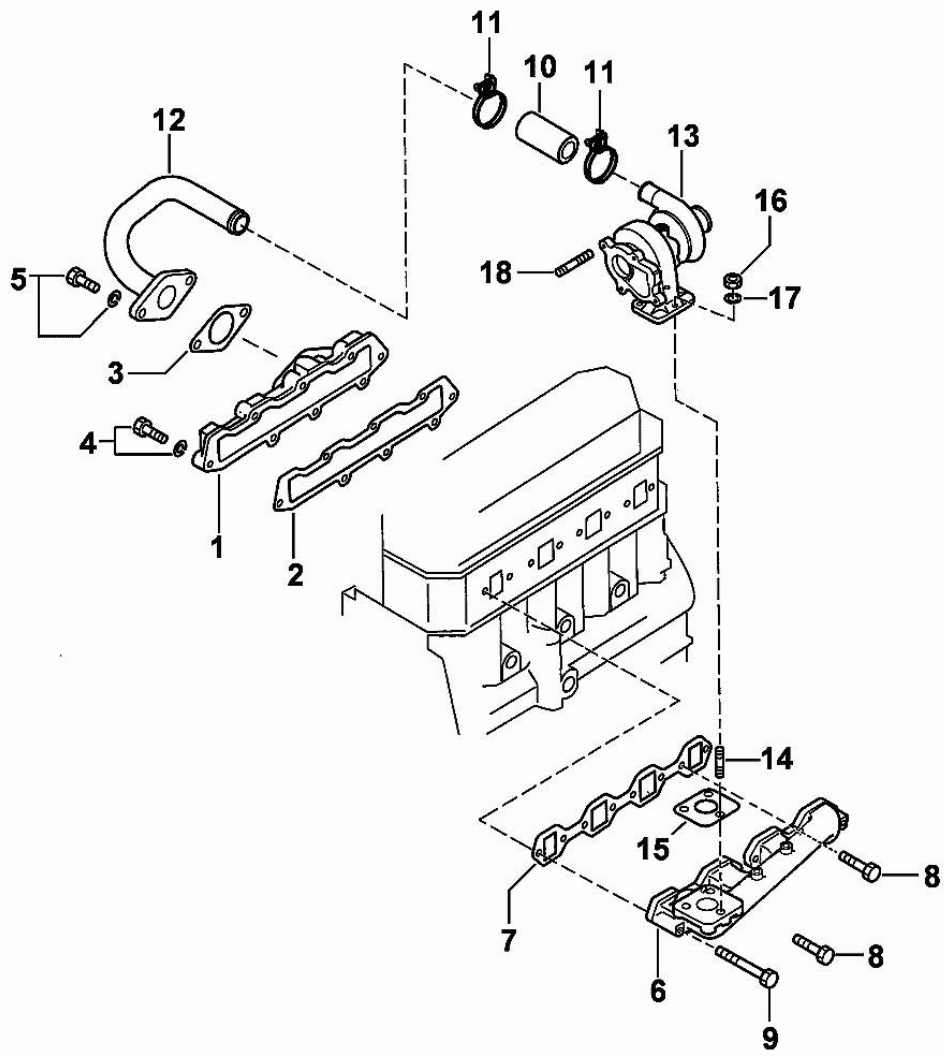

MIT_H36_023-A-001

02011-038E

OIL PUMP

Fig.	P/n	QTY	Name
1	0.010.2684.2	1	oil pump
1.1	0.010.2685.0	1	gasket
2	0.010.2685.1	3	screw

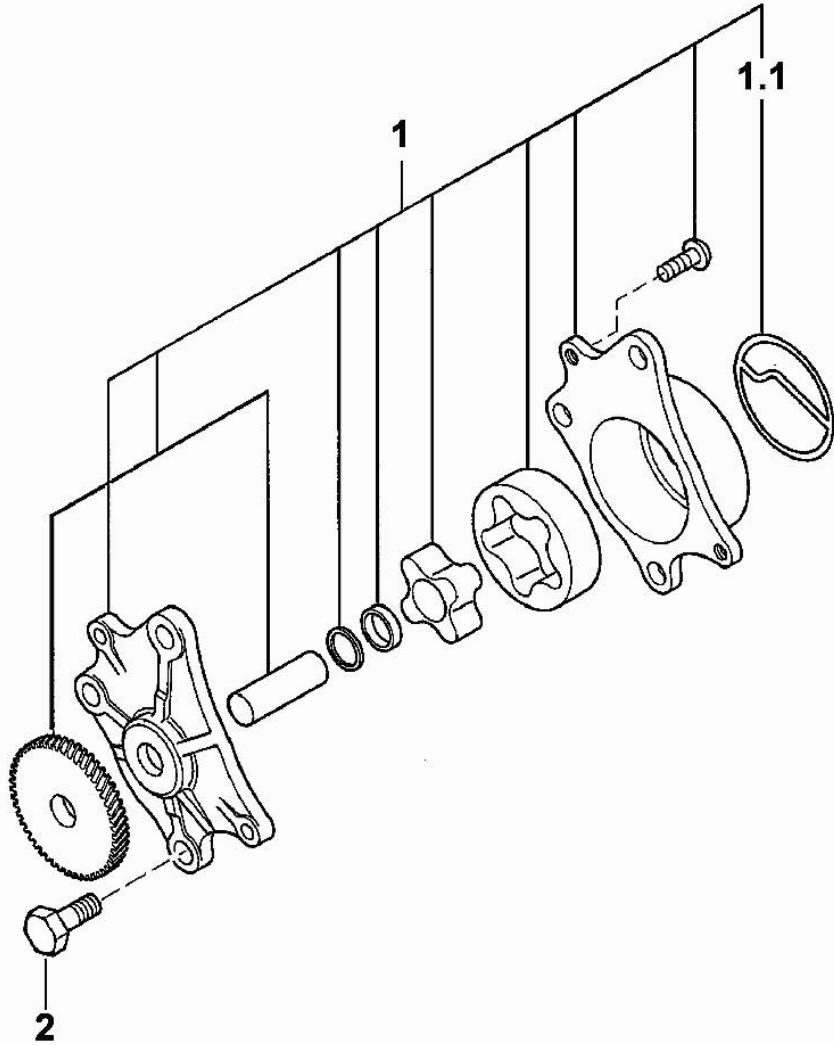

03011-001E

MIT_H36_025-A-001



Suggest:

For more complete manuals. Please go to the home page.

<https://www.ebooklibonline.com>

If the above button click is invalid. Please download this document first, and then click the above link to download the complete manual.

Thank you so much for reading

LUBRICATION

Fig.	P/n	QTY	Name
1	0.010.2685.2	1	tube
1.1	0.009.4634.0	1	self-locking nut
2	0.009.4634.1	1	gasket

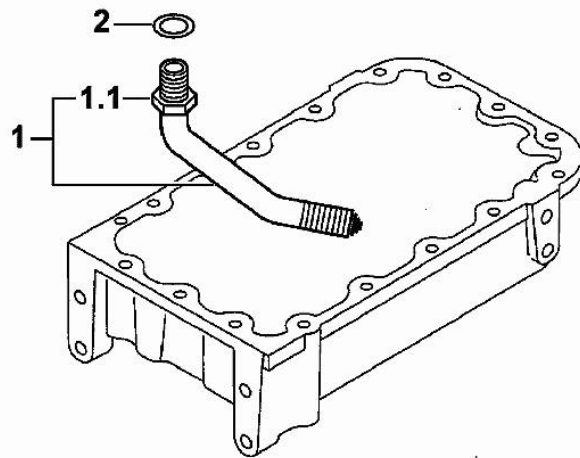
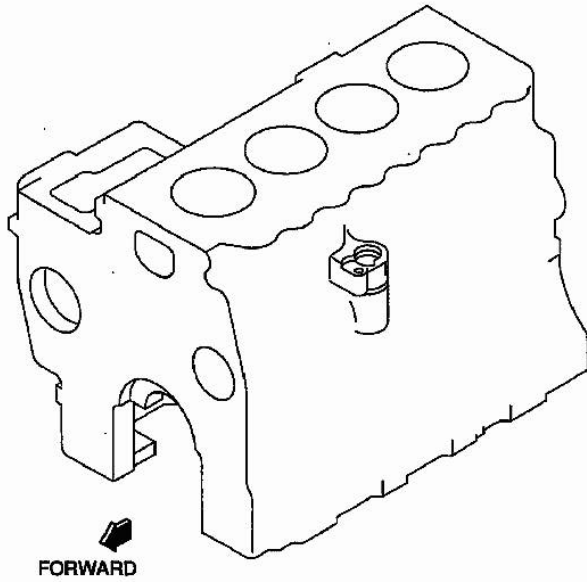

MIT_H36_026-A-001

03031-008E

OIL PIPES FOR TURBOCHARGER

Fig.	P/n	QTY	Name
1	0.010.3974.1	1	tube
2	0.010.2681.2	1	pipe fitting
3	0.009.4843.1	2	gasket
4	0.009.4843.0	1	pipe union
5	0.010.3974.2	1	tube
6	0.010.2224.0	1	gasket
7	0.010.2682.1	2	screw
8	0.009.4630.2	1	ring
9	0.010.2683.2	2	bracket
10	0.010.2684.0	1	screw
11	0.009.4624.0	1	nut
12	0.010.2684.1	1	washer

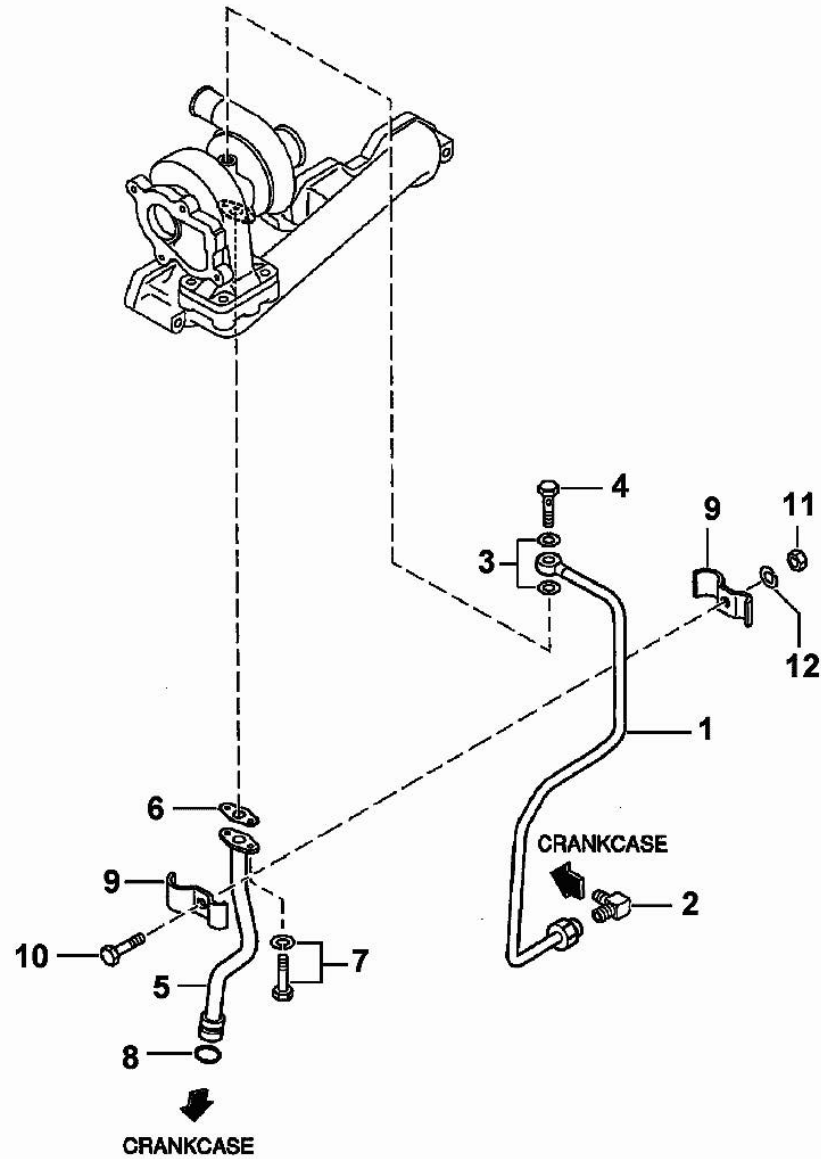

Q2041-002E 45CV

MIT_H36_027-A-001

<https://www.ebooklibonline.com>

Hello dear friend!

Thank you very much for reading.

Enter the link into your browser.

The full manual is available for immediate download.

<https://www.ebooklibonline.com>