

Section: ENGINE
CYLINDER HEAD

| Fig. | P/n | QTY | Name |
|------|-----|-----|------|
|------|-----|-----|------|

Notes:
[PRINCE 40]

| | | | |
|-------|--------------|----|--------------------|
| 1 | 0.010.3986.0 | 1 | engine head |
| 1.2 | 0.000.0000.1 | | cannot be supplied |
| 1.2.1 | 0.010.2634.1 | 1 | plug |
| 1.2.2 | 0.010.2636.1 | 7 | plug |
| 1.2.3 | 0.000.0000.1 | | cannot be supplied |
| 1.2.4 | 0.000.0000.1 | | cannot be supplied |
| 1.2.5 | 0.010.2634.2 | 4 | valve guide |
| 1.2.6 | 0.010.2635.0 | 4 | valve guide |
| 1.2.7 | 0.000.0000.1 | | cannot be supplied |
| 1.2.8 | 0.010.2636.2 | 4 | special bushing |
| 1.3 | 0.009.4545.1 | 1 | plug |
| 4 | 0.010.2633.1 | 14 | screw |
| 5 | 0.010.2635.2 | 1 | gasket |
| 6 | 0.009.4541.2 | 2 | bracket |
| 7 | 0.010.2633.0 | 2 | screw |

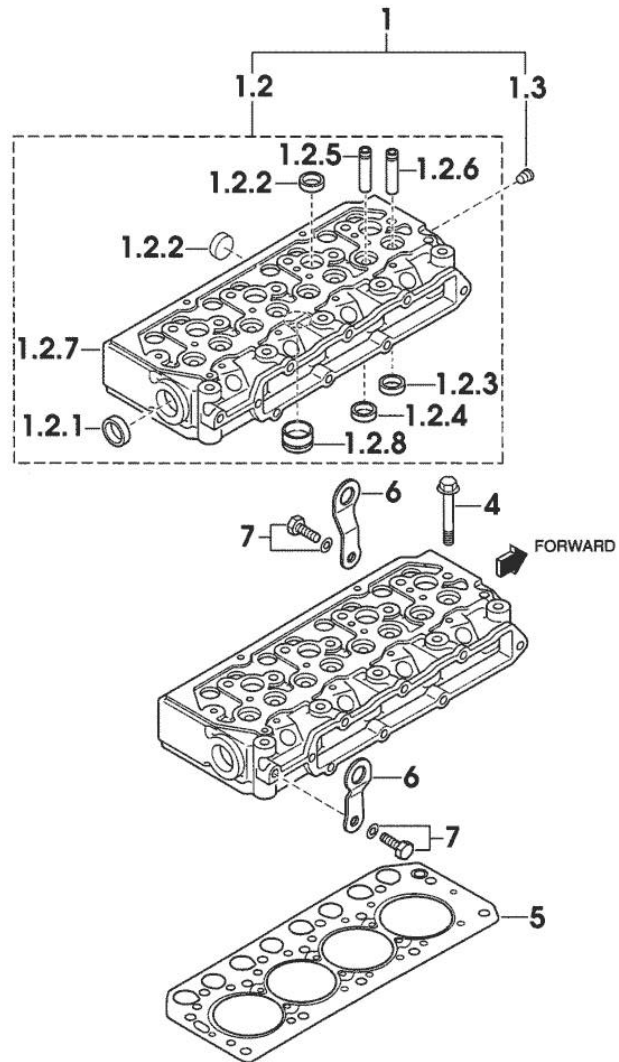

01011-001E 45CV

Section: ENGINE
CYLINDER HEAD

| Fig. | P/n | QTY | Name |
|------|-----|-----|------|
|------|-----|-----|------|

Notes:
[PRINCE 40]

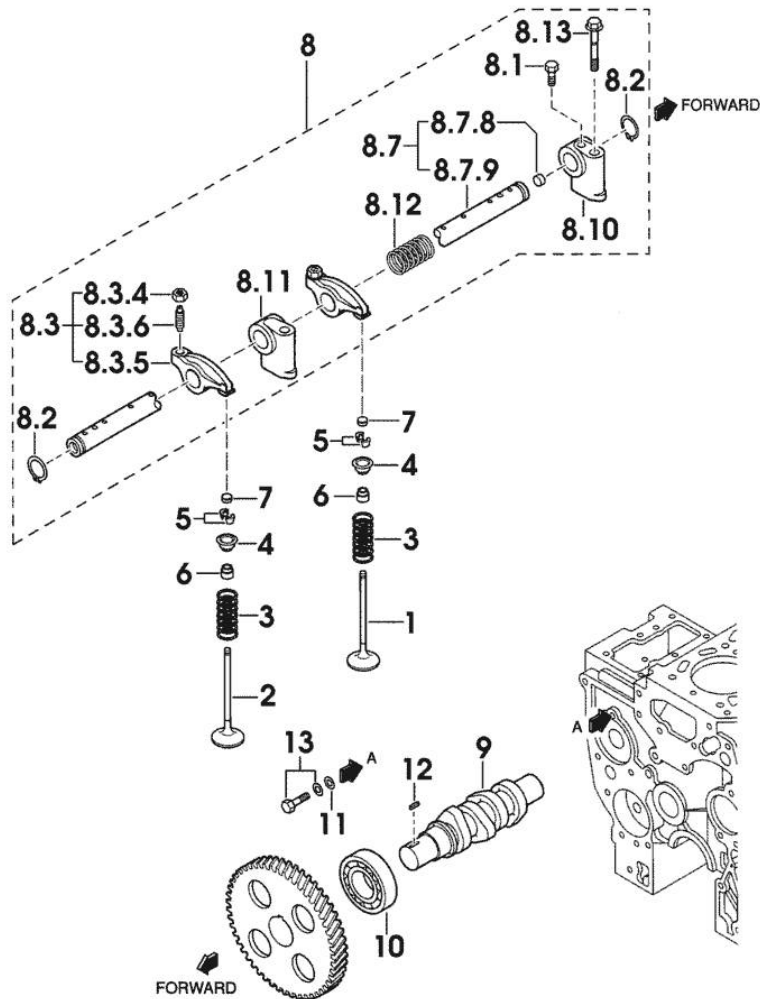

| | | | |
|-------|--------------|----|------------------------|
| 1 | 0.010.2637.2 | 4 | inlet valve Ø mm 6.5 |
| 2 | 0.010.2638.0 | 4 | exhaust valve Ø mm 6.5 |
| 3 | 0.010.2638.1 | 8 | spring |
| 4 | 0.010.3992.2 | 8 | cup |
| 5 | 0.009.4561.2 | 16 | stop |
| 6 | 0.009.4562.0 | 8 | gasket |
| 7 | 0.010.2639.0 | 8 | cap |
| 8 | 0.000.0000.1 | 1 | cannot be supplied |
| 8.1 | 0.010.2640.1 | 1 | screw |
| 8.2 | 0.009.4559.0 | 2 | ring |
| 8.3 | 0.010.3949.0 | 8 | rocker arm |
| 8.3.4 | 0.010.2641.0 | 8 | nut |
| 8.3.5 | 0.000.0000.1 | | cannot be supplied |
| 8.3.6 | 0.010.3949.1 | 8 | register |
| 8.7 | 0.010.2644.1 | 1 | shaft |
| 8.7.8 | 0.010.2643.0 | 2 | plug |
| 8.7.9 | 0.000.0000.1 | | cannot be supplied |
| 8.10 | 0.010.2642.0 | 1 | support |
| 8.11 | 0.010.2642.1 | 3 | support |
| 8.12 | 0.010.2643.1 | 3 | spring |
| 8.13 | 0.010.2643.2 | 4 | screw |
| 9 | 0.010.2644.0 | 1 | camshaft |
| 10 | 0.009.4567.0 | 1 | special bearing |
| 11 | 0.009.4566.0 | 1 | washer |
| 12 | 0.009.4567.2 | 1 | stick |
| 13 | 0.010.2639.1 | 1 | screw |

01021-013E

CYLINDER HEAD COVER

| Fig. | P/n | QTY | Name |
|------|-----|-----|------|
|------|-----|-----|------|

Notes:
[PRINCE 40]

| | | | |
|-----|--------------|---|--------------------|
| 1 | 0.010.2647.1 | 1 | cover |
| 1.1 | 0.000.0000.1 | | cannot be supplied |
| 1.2 | 0.000.0000.1 | | cannot be supplied |
| 2 | 0.010.2647.2 | 1 | gasket |
| 3 | 0.010.2645.2 | 5 | screw |
| 4 | 0.009.4548.0 | 1 | plug |
| 5 | 0.009.4781.2 | 1 | tube |
| 6 | 0.010.2206.0 | 1 | clamp |

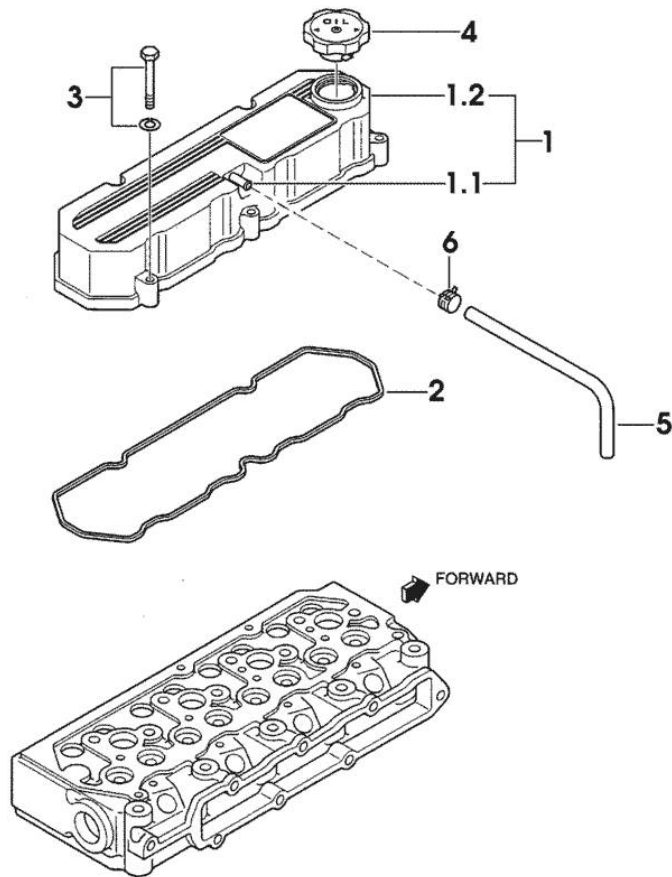

01031-015E

<https://www.ebooklibonline.com>

Hello dear friend!

Thank you very much for reading.

Enter the link into your browser.

The full manual is available for immediate download.

<https://www.ebooklibonline.com>

CAMSHAFT

| Fig. | P/n | QTY | Name |
|------|-----|-----|------|
|------|-----|-----|------|

Notes:
[PRINCE 40]

| | | | |
|---|--------------|---|-------------|
| 1 | 0.010.3949.2 | 1 | camshaft |
| 2 | 0.009.4555.1 | 1 | key |
| 3 | 0.010.3950.0 | 1 | small plate |
| 4 | 0.010.2639.1 | 2 | screw |
| 5 | 0.010.3950.1 | 8 | tappets |
| 6 | 0.010.2646.2 | 8 | rod |

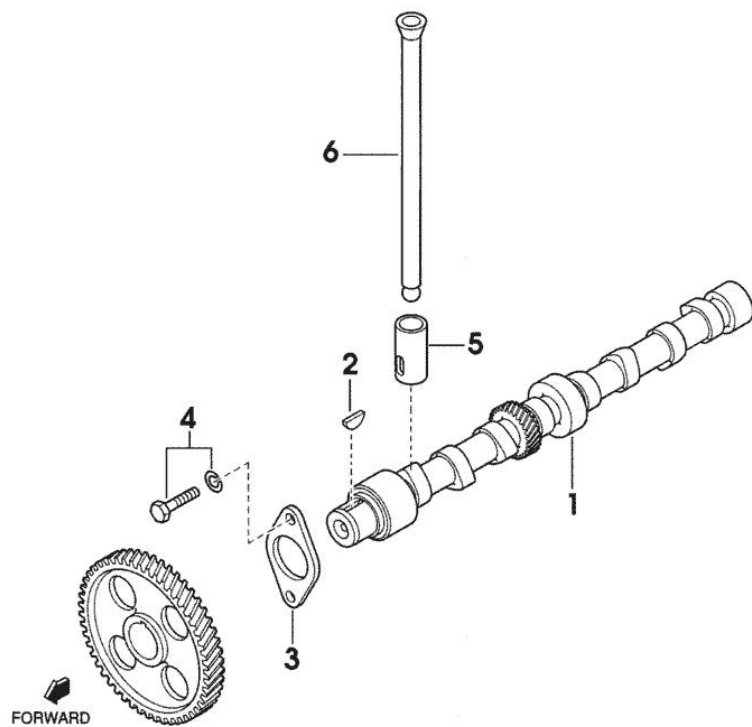

01031-016E

Section: ENGINE

CRANKCASE

| Fig. | P/n | QTY | Name |
|------|-----|-----|------|
|------|-----|-----|------|

Notes:
[PRINCE 40]

| | | | |
|----------|--------------|----|--------------------|
| 1 | 0.010.3961.1 | 1 | crankcase |
| 1.2 | 0.000.0000.1 | | cannot be supplied |
| 1.2.1 | 0.010.2652.1 | 3 | special bushing |
| 1.2.2 | 0.010.2652.2 | 3 | special bushing |
| 1.2.3 | 0.010.2653.0 | 10 | screw |
| 1.2.4 | 0.010.2653.1 | 1 | special bushing |
| 1.2.5 | 0.000.0000.1 | | cannot be supplied |
| 1.2.5.6 | 0.000.0000.1 | | cannot be supplied |
| 1.2.5.7 | 0.000.0000.1 | | cannot be supplied |
| 1.2.5.8 | 0.000.0000.1 | | cannot be supplied |
| 1.2.5.9 | 0.000.0000.1 | | cannot be supplied |
| 1.2.5.10 | 0.000.0000.1 | | cannot be supplied |
| 1.2.11 | 0.000.0000.1 | | cannot be supplied |
| 1.3 | 0.009.4523.2 | 1 | guide |
| 1.4 | 0.010.2649.0 | 1 | plug |
| 1.5 | 0.010.2649.1 | 3 | special bushing |
| 1.6 | 0.009.4545.1 | 1 | plug |
| 1.7 | 0.009.4524.2 | 4 | special bushing |
| 1.8 | 0.009.4525.1 | 2 | special bushing |
| 1.9 | 0.009.4525.2 | 1 | special bushing |
| 1.10 | 0.009.4524.1 | 1 | expansion plug |
| 1.11 | 0.010.3951.0 | 1 | pin |
| 1.12 | 0.009.4523.0 | 2 | pin |
| 1.13 | 0.010.2650.0 | 1 | pin |
| 1.13.1 | 0.010.2650.1 | 1 | ball |
| 1.13.2 | 0.000.0000.1 | | cannot be supplied |
| 1.15 | 0.010.2651.0 | 2 | pin |
| 1.16 | 0.010.2651.1 | 1 | plug |
| 1.17 | 0.010.3961.2 | 4 | sprayers |
| 18 | 0.010.2648.1 | 4 | screw |
| 20 | 0.010.2651.2 | 4 | gasket |

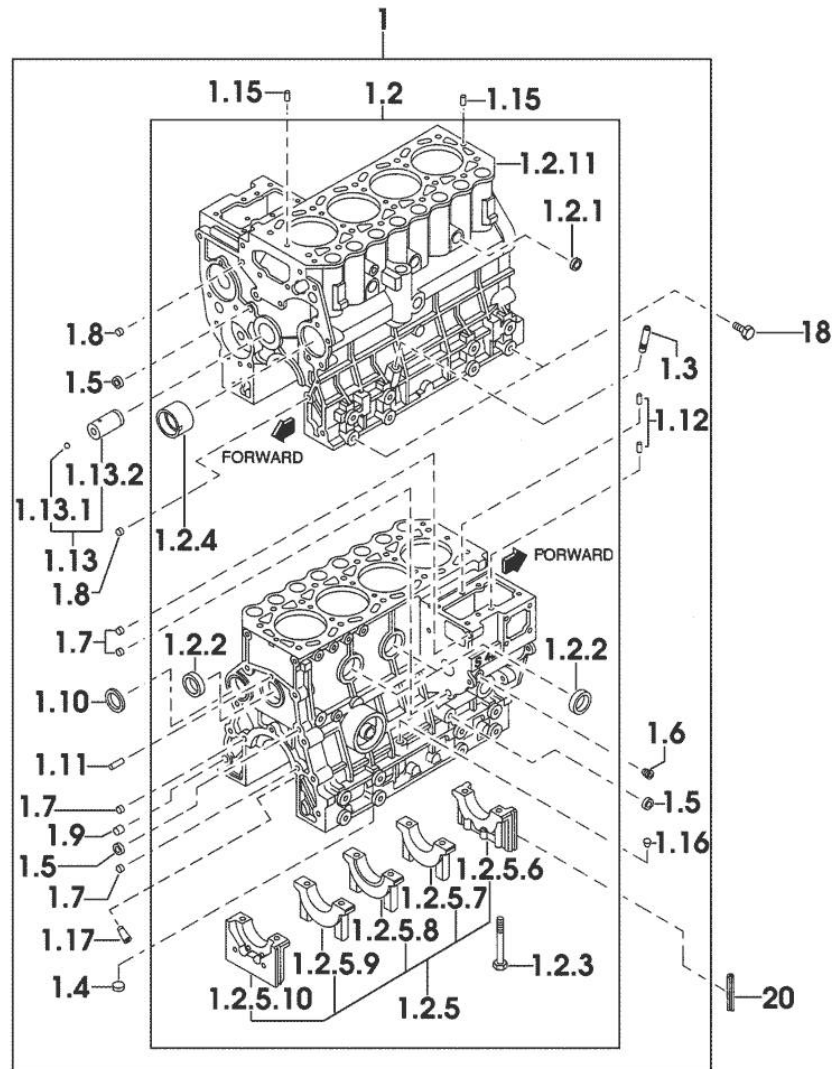

01041-019E 45CV

Section: ENGINE

MAIN BEARINGS

| Fig. | P/n | QTY | Name |
|------|-----|-----|------|
|------|-----|-----|------|

Notes:
[PRINCE 40]

| | | | |
|---|--------------|---|-----------------------------|
| 1 | 0.010.2656.2 | 1 | main half bushing STANDARD |
| 2 | 0.010.2657.0 | 1 | main half bushing - mm 0.25 |
| 3 | 0.010.2657.1 | 1 | main half bushing - mm 0.50 |
| 4 | 0.010.2657.2 | 1 | main half bushing - mm 0.75 |

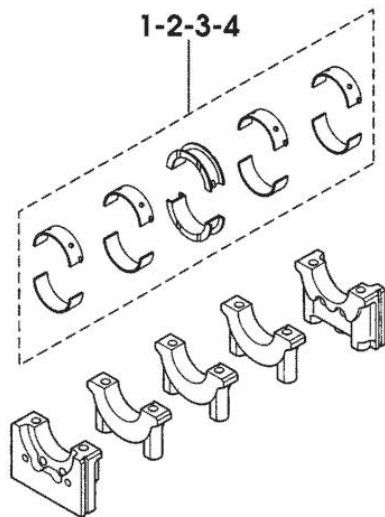
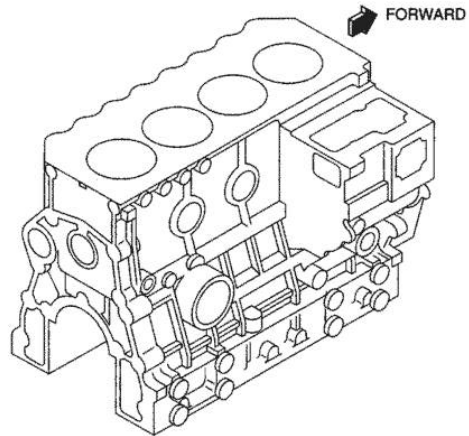

0104B1-001E

Section: ENGINE
TIMING CASE

| Fig. | P/n | QTY | Name |
|------|-----|-----|------|
|------|-----|-----|------|

Notes:
[PRINCE 40]

| | | | |
|----|--------------|----|---------------|
| 1 | 0.010.2658.0 | 1 | plate |
| 2 | 0.010.2658.1 | 1 | gasket |
| 3 | 0.010.2639.1 | 10 | screw |
| 4 | 0.010.3951.1 | 1 | flange |
| 5 | 0.010.2659.0 | 1 | gasket |
| 6 | 0.010.2659.1 | 8 | screw |
| 7 | 0.009.4537.0 | 1 | gasket |
| 8 | 0.010.3951.2 | 1 | plug |
| 9 | 0.010.2660.0 | 1 | flange |
| 10 | 0.010.2660.1 | 1 | gasket |
| 11 | 0.009.4756.0 | 2 | cover |
| 12 | 0.010.3952.0 | 2 | gasket |
| 13 | 0.010.2661.0 | 1 | screw |
| 14 | 0.010.2661.1 | 2 | nut |
| 15 | 0.010.3952.1 | 1 | screw |
| 16 | 0.010.3952.2 | 2 | screw |
| 17 | 0.009.4539.2 | 2 | spring washer |
| 18 | 0.010.3953.0 | 1 | cover |
| 19 | 0.010.2662.2 | 4 | screw |
| 20 | 0.010.2663.0 | 4 | washer |

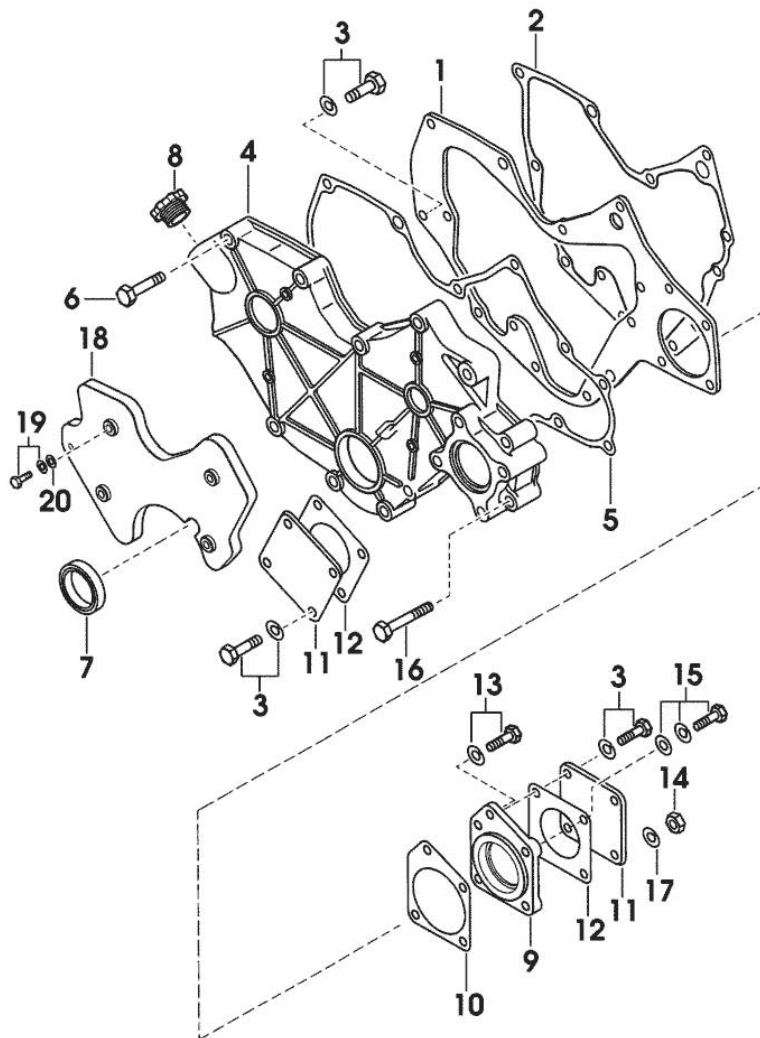

01051-018

Section: ENGINE

FLYWHEEL HOUSING

| Fig. | P/n | QTY | Name |
|------|-----|-----|------|
|------|-----|-----|------|

Notes:
[PRINCE 40]

| | | | |
|---|--------------|----|------------------|
| 1 | 0.010.2654.2 | 1 | flange |
| 2 | 0.010.2655.0 | 1 | gasket |
| 3 | 0.010.2655.1 | 1 | special oil seal |
| 4 | 0.010.2655.2 | 5 | screw |
| 5 | 0.010.3953.1 | 1 | flange |
| 6 | 0.009.4532.2 | 1 | pin |
| 7 | 0.010.3953.2 | 10 | screw |

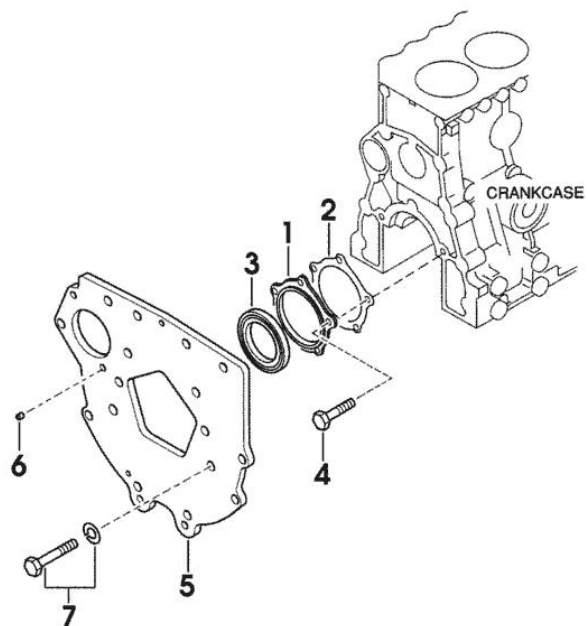

01061-019E

OIL PAN

| Fig. | P/n | QTY | Name |
|------|-----|-----|------|
|------|-----|-----|------|

Notes:
[PRINCE 40]

| | | | |
|-----|--------------|----|--------------------|
| 1 | 0.010.3954.0 | 1 | oil sump |
| 1.1 | 0.010.2664.0 | 1 | plug |
| 1.2 | 0.010.2663.2 | 1 | gasket |
| 1.3 | 0.000.0000.1 | | cannot be supplied |
| 2 | 0.010.3954.1 | 12 | screw |
| 3 | 0.010.2664.2 | 1 | screw |
| 4 | 0.010.2665.0 | 4 | screw |
| 5 | 0.010.2665.1 | 5 | washer |
| 6 | 0.010.2687.1 | 1 | dipstick |

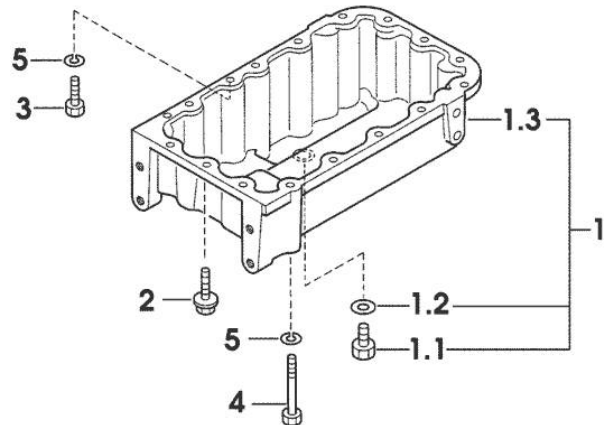
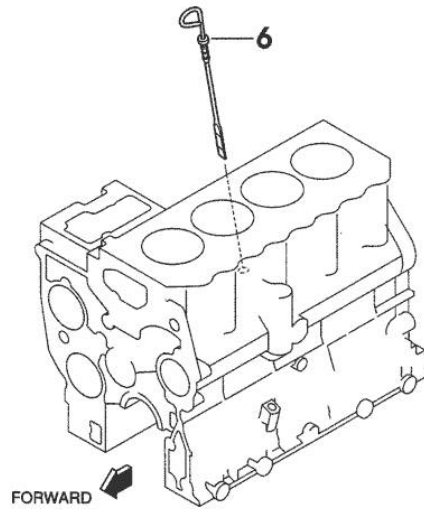

01071-038E



Suggest:

For more complete manuals. Please go to the home page.

<https://www.ebooklibonline.com>

If the above button click is invalid. Please download this document first, and then click the above link to download the complete manual.

Thank you so much for reading

PISTON - CONNECTING ROD

| Fig. | P/n | QTY | Name |
|------|-----|-----|------|
|------|-----|-----|------|

Notes:
[PRINCE 40]

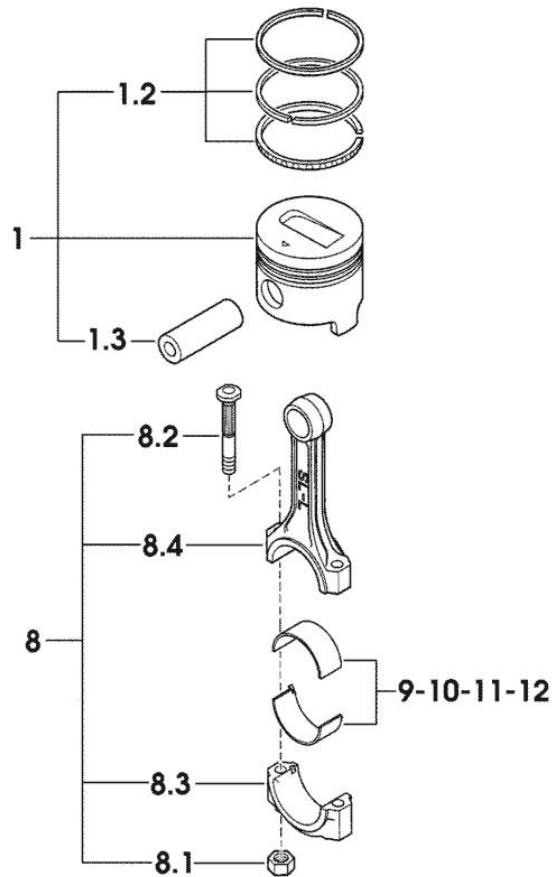

| | | | |
|-----|--------------|---|--------------------------------|
| 1 | 0.009.0060.6 | 4 | complete piston STANDARD |
| 1 | 0.009.0061.6 | 4 | complete piston + mm 0.25 |
| 1 | 0.009.0062.6 | 4 | complete piston + mm 0.50 |
| 1.2 | 0.008.0052.6 | 4 | piston ring set STANDARD |
| 1.2 | 0.008.0053.6 | 4 | piston ring set + mm 0.25 |
| 1.2 | 0.008.0054.6 | 4 | piston ring set + mm 0.50 |
| 1.3 | 0.010.2668.0 | 4 | piston pin |
| 8 | 0.010.2671.2 | 4 | engine connecting rod |
| 8.1 | 0.009.4783.0 | 8 | nut |
| 8.2 | 0.010.2668.2 | 8 | screw |
| 8.3 | 0.000.0000.1 | | cannot be supplied |
| 8.4 | 0.000.0000.1 | | cannot be supplied |
| 9 | 0.009.4782.1 | 4 | con.rod half bushing STANDARD |
| 10 | 0.010.2669.0 | 4 | con.rod half bushing - mm 0.25 |
| 11 | 0.010.2669.1 | 4 | con.rod half bushing - mm 0.50 |
| 12 | 0.010.2669.2 | 4 | con.rod half bushing - mm 0.75 |

0108A1-002 45CV

CRANKSHAFT - FLYWHEEL

| Fig. | P/n | QTY | Name |
|------|-----|-----|------|
|------|-----|-----|------|

Notes:
[PRINCE 40]

| | | | |
|-----|--------------|---|--------------------|
| 1 | 0.010.2672.0 | 1 | crankshaft |
| 2 | 0.009.4555.1 | 2 | key |
| 3 | 0.009.4554.2 | 1 | flat washer |
| 4 | 0.009.4555.0 | 1 | spring washer |
| 5 | 0.009.4554.1 | 1 | nut |
| 6 | 0.010.2672.2 | 1 | pulley |
| 7 | 0.010.3954.2 | 1 | flywheel |
| 7.1 | 0.010.2671.0 | 1 | crown wheel Z=110 |
| 7.2 | 0.000.0000.1 | 1 | cannot be supplied |
| 8 | 0.009.4557.0 | 4 | screw |
| 9 | 0.010.3955.0 | 1 | gear Z = 28 |
| 10 | 0.009.4556.1 | 1 | special bearing |

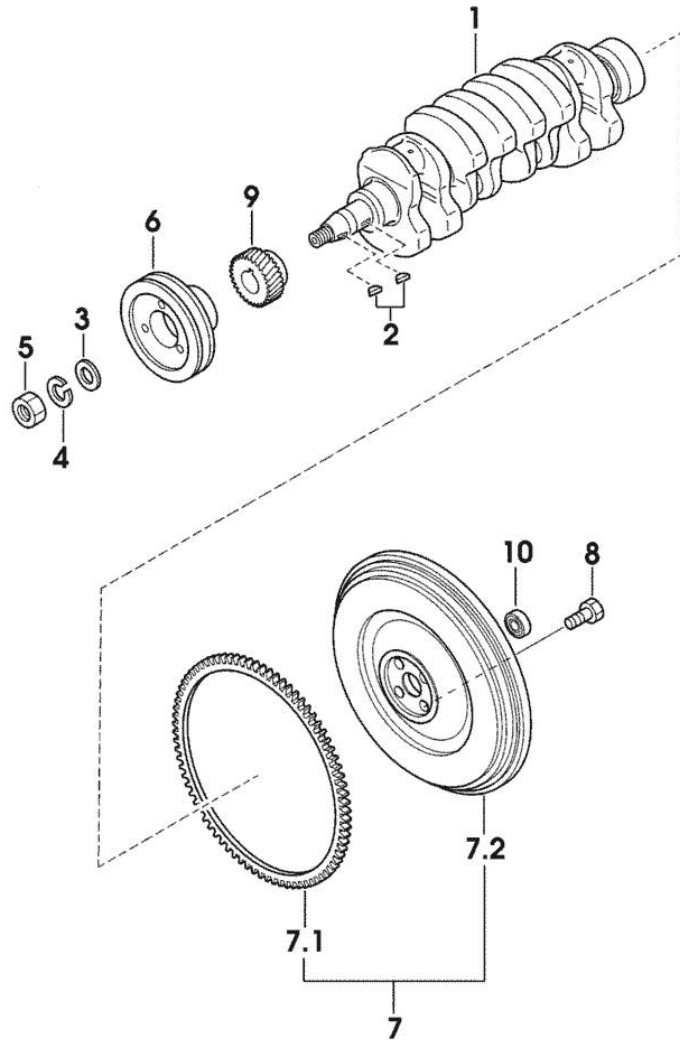

0108B1-021

<https://www.ebooklibonline.com>

Hello dear friend!

Thank you very much for reading.

Enter the link into your browser.

The full manual is available for immediate download.

<https://www.ebooklibonline.com>