



Section: B0 - ENGINE  
**CYLINDER HEAD**

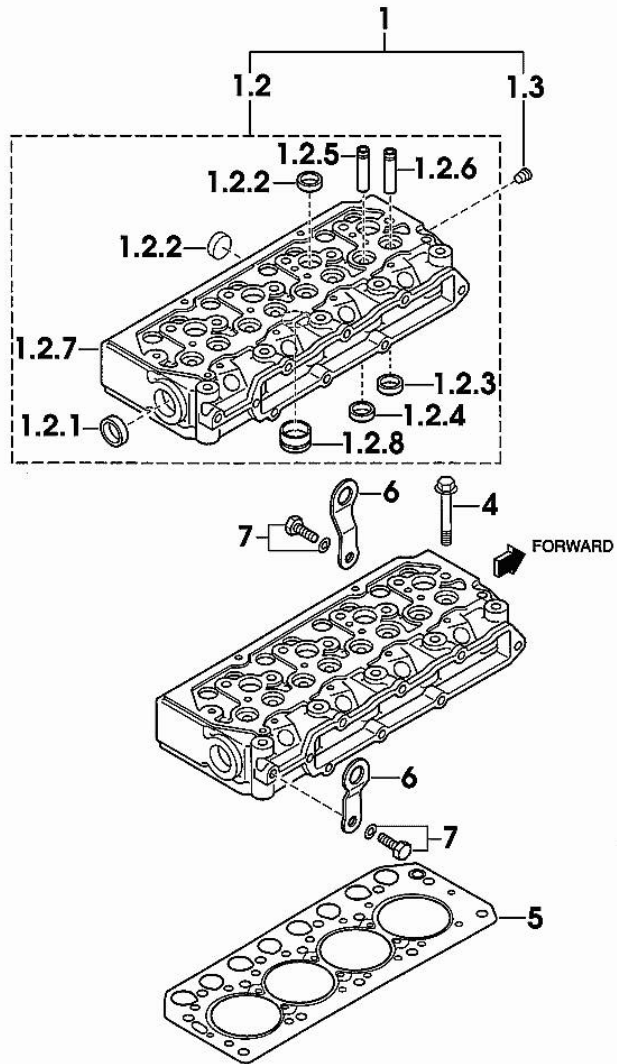
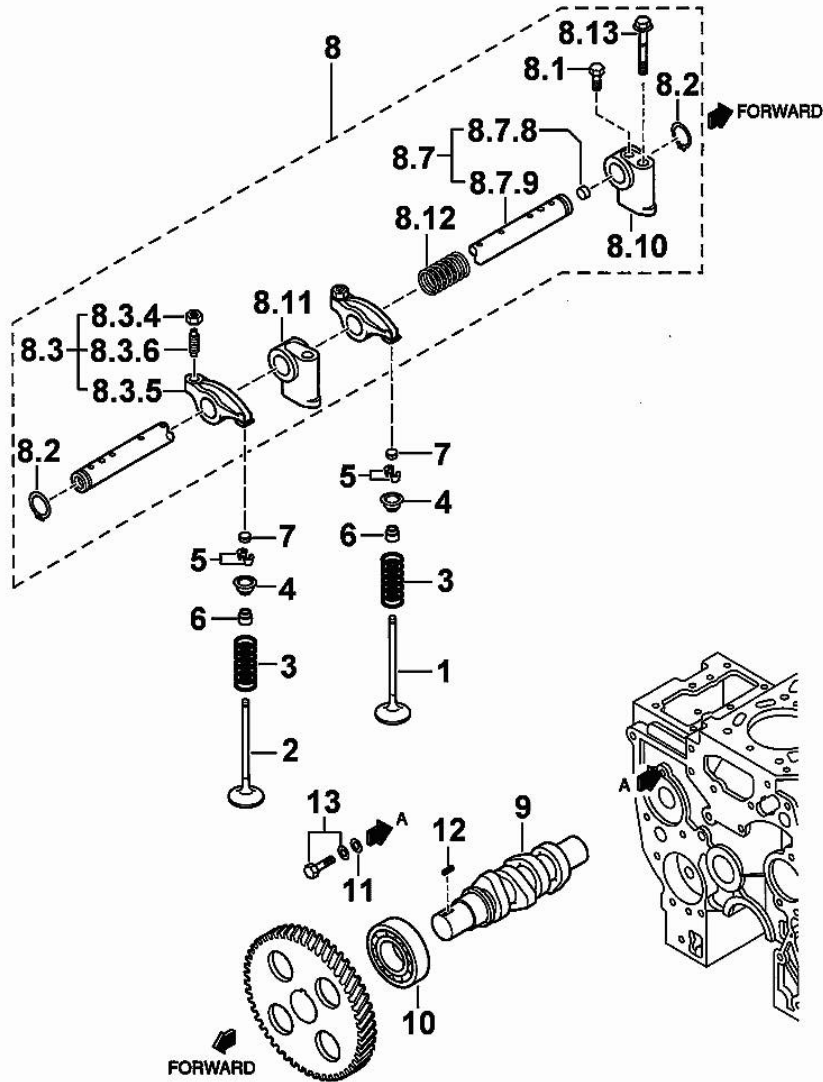

Fig.	P/n	QTY	Name
1	0.010.3948.1	1	engine head
1.2	0.000.0000.1		cannot be supplied
1.2.1	0.010.2634.1	1	plug
1.2.2	0.009.4527.0	7	plug
1.2.3	0.000.0000.1		cannot be supplied
1.2.4	0.000.0000.1		cannot be supplied
1.2.5	0.010.2634.2	4	valve guide
1.2.6	0.010.2635.0	4	valve guide
1.2.7	0.000.0000.1		cannot be supplied
1.2.8	0.010.2637.1	4	special bushing
1.3	0.009.4545.1	1	plug
4	0.010.2633.1	14	screw
5	0.010.2635.2	1	gasket
6	0.009.4541.2	2	bracket
7	0.010.2633.0	2	screw

01011-001E 35CV

Section: B0 - ENGINE  
CYLINDER HEAD

Fig.	P/n	QTY	Name
1	0.010.2637.2	4	inlet valve Ø mm 6.5
2	0.010.2638.0	4	exhaust valve Ø mm 6.5
3	0.010.2638.1	8	spring
4	0.000.0000.1	8	cannot be supplied
5	0.009.4561.2	16	stop
6	0.009.4562.0	8	gasket
7	0.010.2639.0	8	cap
8	0.000.0000.1	1	cannot be supplied
8.1	0.010.2640.1	1	screw
8.2	0.009.4559.0	2	ring
8.3	0.010.3949.0	8	rocker arm
8.3.4	0.010.2641.0	8	nut
8.3.5	0.000.0000.1		cannot be supplied
8.3.6	0.010.3949.1	8	register
8.7	0.010.2644.1	1	shaft
8.7.8	0.010.2643.0	2	plug
8.7.9	0.000.0000.1		cannot be supplied
8.10	0.010.2642.0	1	support
8.11	0.010.2642.1	3	support
8.12	0.010.2643.1	3	spring
8.13	0.010.2643.2	4	screw
9	0.010.2644.0	1	camshaft
10	0.009.4567.0	1	special bearing
11	0.009.4566.0	1	washer
12	0.009.4567.2	1	stick
13	0.010.2639.1	1	screw



MIT\_H36\_004-A-001

01021-013E

**<https://www.ebooklibonline.com>**

Hello dear friend!

Thank you very much for reading.

Enter the link into your browser.

The full manual is available for immediate download.

**<https://www.ebooklibonline.com>**

**CAMSHAFT**

Fig.	P/n	QTY	Name
1	0.010.3949.2	1	camshaft
2	0.009.4555.1	1	key
3	0.010.3950.0	1	small plate
4	0.010.2639.1	2	screw
5	0.010.3950.1	8	tappets
6	0.010.2646.2	8	rod

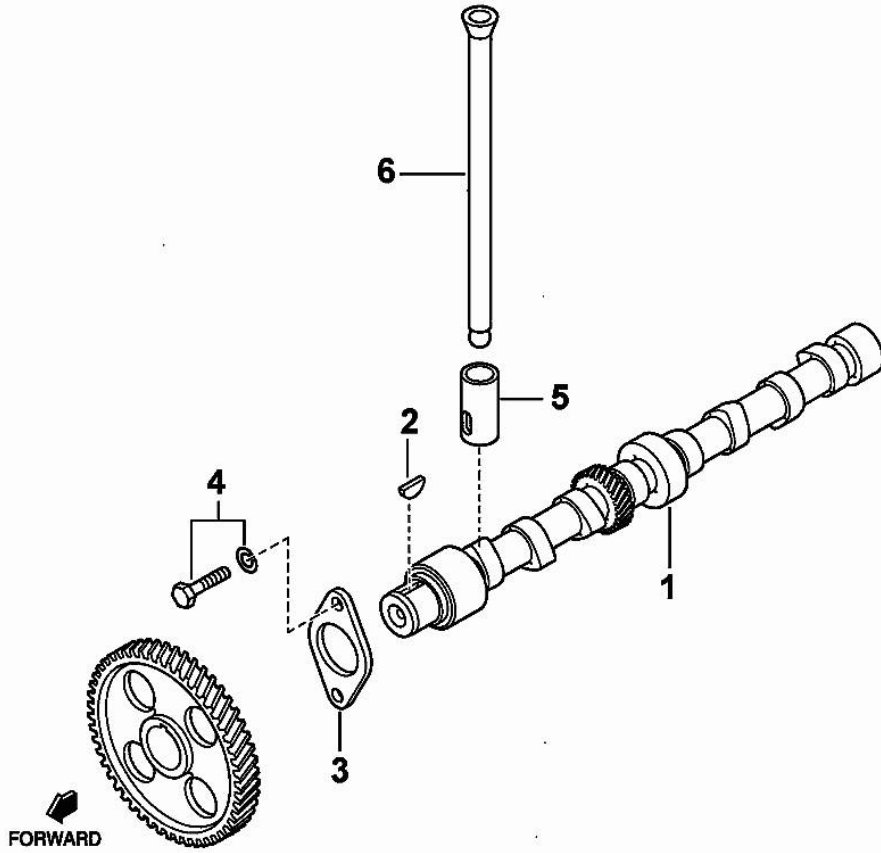

01031-016E

MIT\_H36\_007-A-001

**CYLINDER HEAD COVER**

Fig.	P/n	QTY	Name
1	0.010.2647.1	1	cover
1.1	0.000.0000.1		cannot be supplied
1.2	0.000.0000.1		cannot be supplied
2	0.010.2647.2	1	gasket
3	0.010.2645.2	5	screw
4	0.009.4548.0	1	plug
5	0.010.2647.0	1	tube

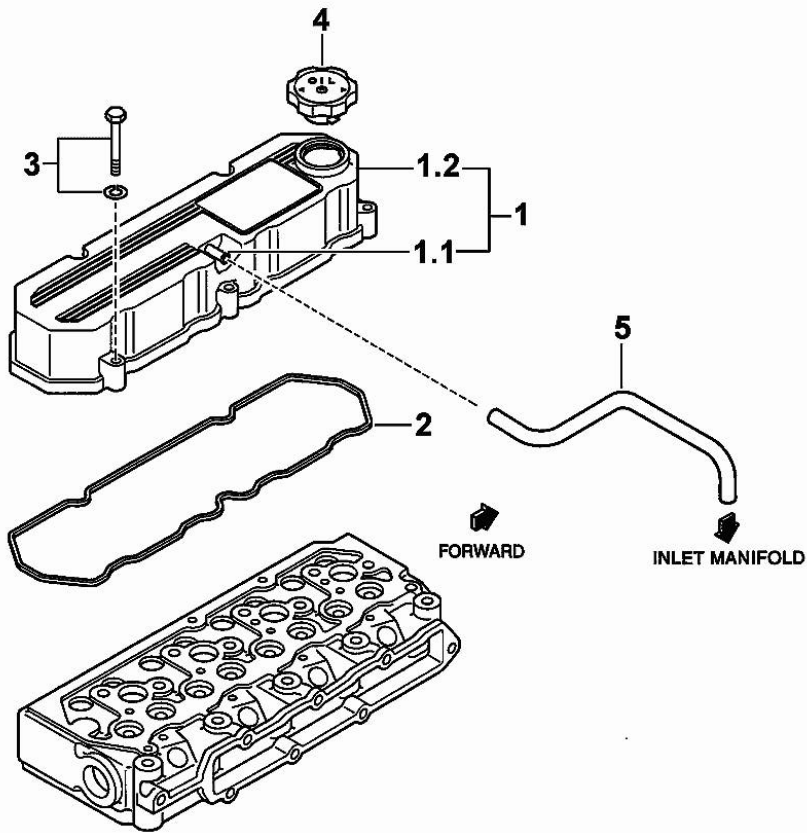

MIT\_H36\_005-A-001

01031-021E

**CRANKCASE**

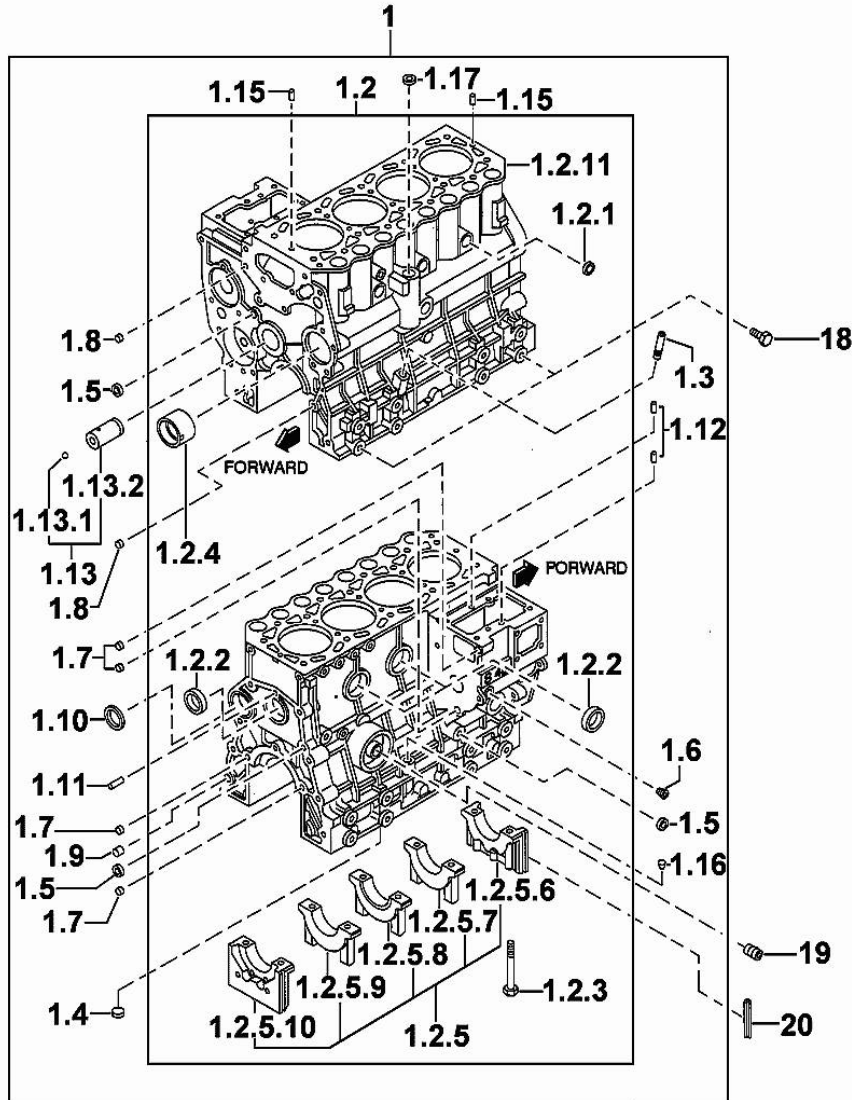

Fig.	P/n	QTY	Name
1	0.010.3950.2	1	crankcase
1.2	0.000.0000.1		cannot be supplied
1.2.1	0.010.2652.1	3	special bushing
1.2.2	0.010.2652.2	3	special bushing
1.2.3	0.010.2653.0	10	screw
1.2.4	0.010.2653.1	1	special bushing
1.2.5	0.000.0000.1		cannot be supplied
1.2.5.6	0.000.0000.1		cannot be supplied
1.2.5.7	0.000.0000.1		cannot be supplied
1.2.5.8	0.000.0000.1		cannot be supplied
1.2.5.9	0.000.0000.1		cannot be supplied
1.2.5.10	0.000.0000.1		cannot be supplied
1.2.11	0.000.0000.1		cannot be supplied
1.3	0.009.4523.2	1	guide
1.4	0.010.2649.0	1	plug
1.5	0.010.2649.1	3	special bushing
1.6	0.009.4545.1	1	plug
1.7	0.009.4524.2	4	special bushing
1.8	0.009.4525.1	2	special bushing
1.9	0.009.4525.2	1	special bushing
1.10	0.009.4524.1	1	expansion plug
1.11	0.010.3951.0	1	pin
1.12	0.009.4523.0	2	pin
1.13	0.010.2650.0	1	pin
1.13.1	0.000.0000.1	1	cannot be supplied
1.13.2	0.000.0000.1	1	cannot be supplied
1.15	0.010.2651.0	2	pin
1.16	0.010.2651.1	1	plug
1.17	0.010.2648.2	1	plug
18	0.010.2648.1	4	screw
19	0.010.2650.2	1	pipe fitting
20	0.010.2651.2	4	gasket

MIT\_H36\_008-A-001

01041-048E

Section: B0 - ENGINE

**MAIN BEARINGS**

Fig.	P/n	QTY	Name
1	0.009.4530.0	1	plug
2	0.009.4531.0	1	main half bushing STANDARD
3	0.009.4531.1	1	main half bushing - mm 0.25
4	0.009.4531.2	1	main half bushing - mm 0.50
5	0.009.4532.0	1	main half bushing - mm 0.75

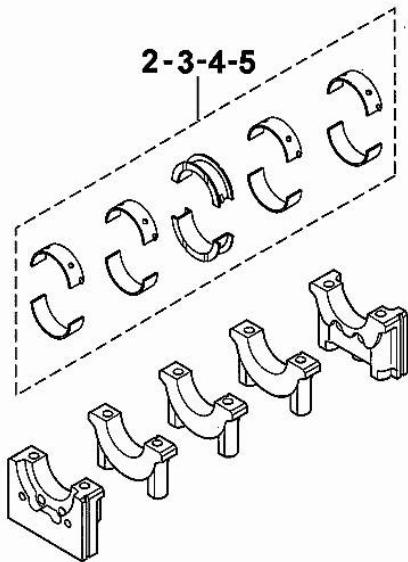
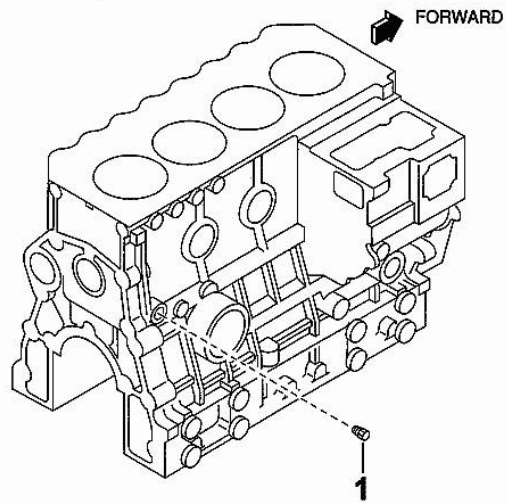

MIT\_H36\_011-A-001

0104B1-003E

**TIMING CASE**

Fig.	P/n	QTY	Name
1	0.010.2658.0	1	plate
2	0.010.2658.1	1	gasket
3	0.010.2639.1	10	screw
4	0.010.3951.1	1	flange
5	0.010.2659.0	1	gasket
6	0.010.2659.1	8	screw
7	0.009.4537.0	1	gasket
8	0.010.3951.2	1	plug
9	0.010.2660.0	1	flange
10	0.010.2660.1	1	gasket
11	0.009.4756.0	2	cover
12	0.010.3952.0	2	gasket
13	0.010.2661.0	1	screw
14	0.010.2661.1	2	nut
15	0.010.3952.1	1	screw
16	0.010.3952.2	2	screw
17	0.009.4539.2	2	spring washer
18	0.010.3953.0	1	cover
19	0.010.2662.2	4	screw
20	0.010.2663.0	4	washer

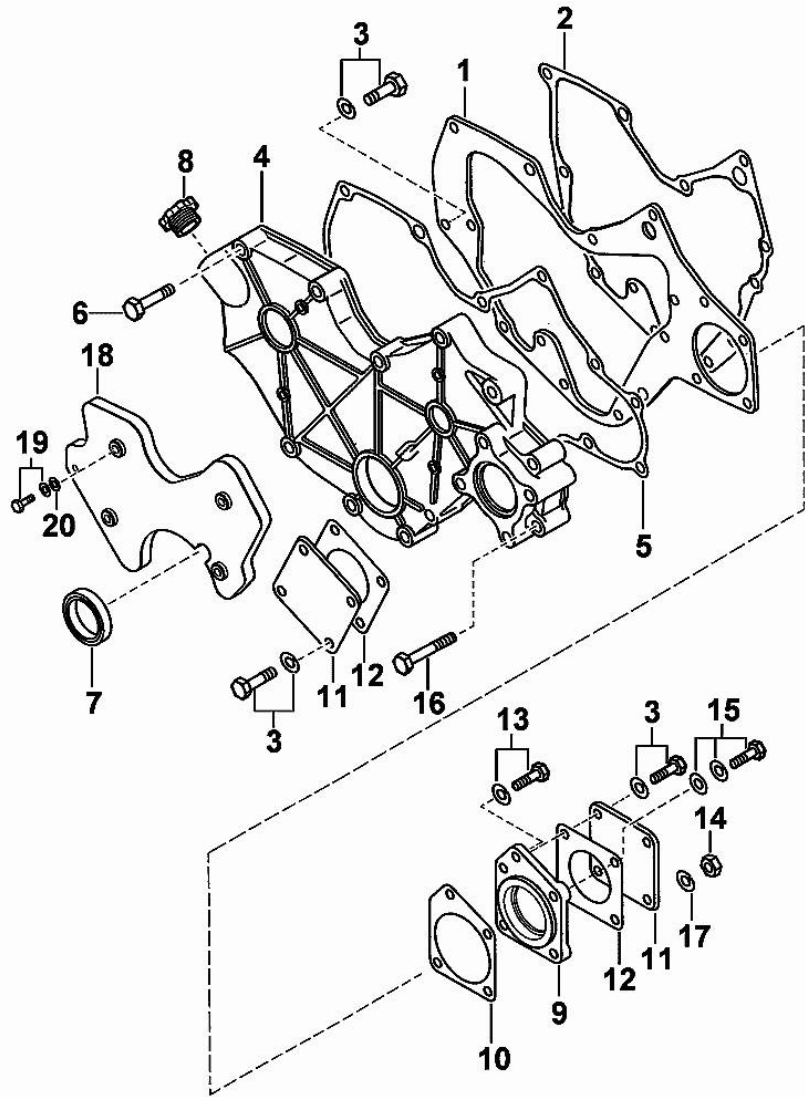

MIT\_H36\_013-A-001

01051-018

**FLYWHEEL HOUSING**

Fig.	P/n	QTY	Name
1	0.010.2654.2	1	flange
2	0.010.2655.0	1	gasket
3	0.010.2655.1	1	special oil seal
4	0.010.2655.2	5	screw
5	0.010.3953.1	1	flange
6	0.009.4532.2	1	pin
7	0.010.3953.2	10	screw

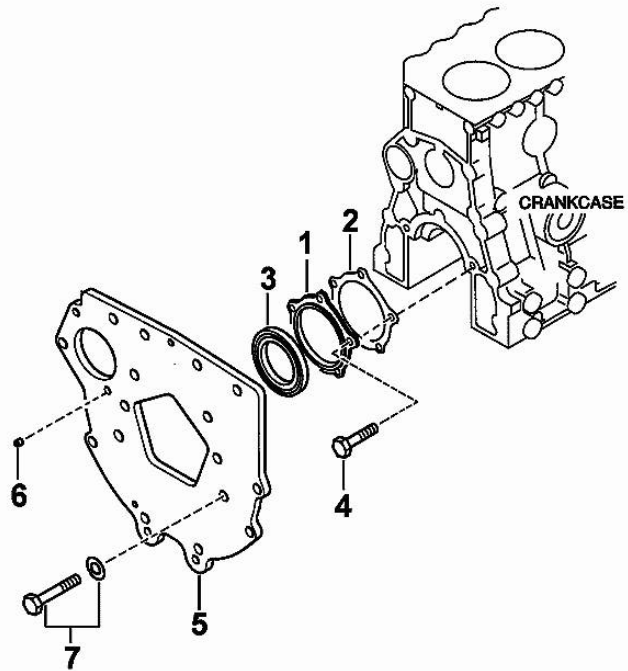

MIT\_H36\_014-A-001

01061-019E

**OIL PAN**

Fig.	P/n	QTY	Name
1	0.010.3954.0	1	oil sump
1.1	0.010.2664.0	1	plug
1.2	0.010.2663.2	1	gasket
1.3	0.000.0000.1		cannot be supplied
2	0.010.3954.1	12	screw
3	0.010.2664.2	1	screw
4	0.010.2665.0	4	screw
5	0.010.2665.1	5	washer
6	0.010.2687.1	1	dipstick

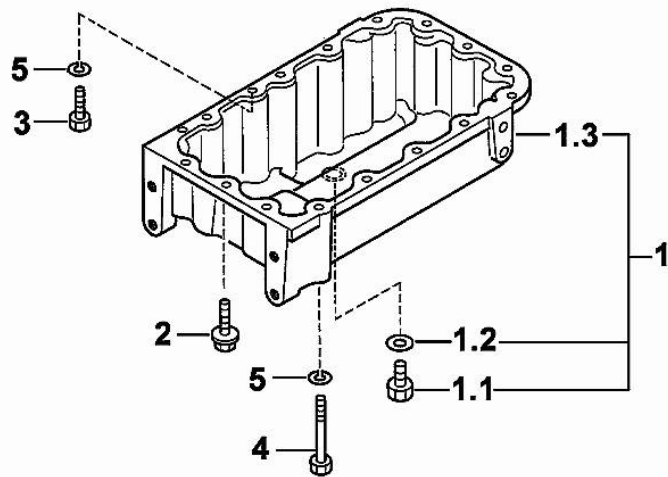
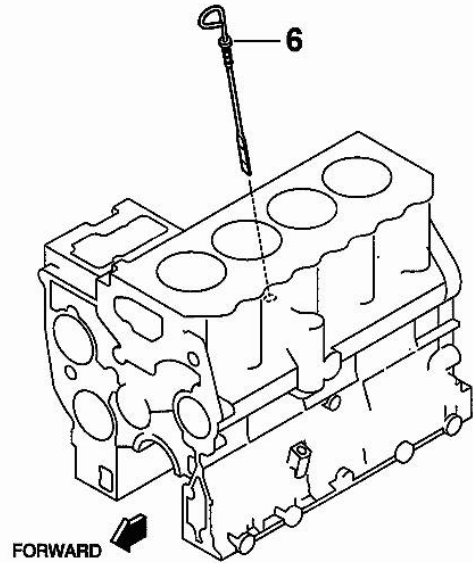

MIT\_H36\_015-A-001

01071-038E

**PISTON - CONNECTING ROD**

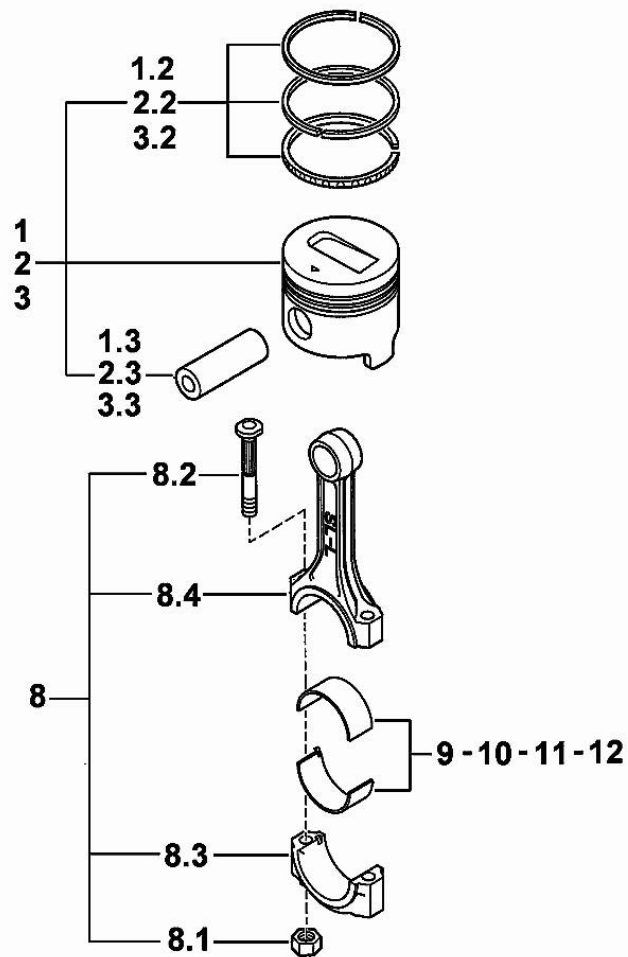

Fig.	P/n	QTY	Name
1	0.007.0060.6	4	complete piston STANDARD
1.2	0.008.0052.6	4	piston ring set STANDARD
1.3	0.010.2668.0	4	piston pin
2	0.007.0061.6	4	complete piston + mm 0.25
2.2	0.008.0053.6	4	piston ring set + mm 0.25
2.3	0.010.2668.0	4	piston pin
3	0.007.0062.6	4	complete piston + mm 0.50
3.2	0.008.0054.6	4	piston ring set + mm 0.50
3.3	0.010.2668.0	4	piston pin
8	0.010.2671.2	4	engine connecting rod
8.1	0.009.4783.0	8	nut
8.2	0.010.2668.2	8	screw
8.3	0.000.0000.1		cannot be supplied
8.4	0.000.0000.1		cannot be supplied
9	0.009.4782.1	4	con.rod half bushing STANDARD
10	0.010.2669.0	4	con.rod half bushing - mm 0.25
11	0.010.2669.1	4	con.rod half bushing - mm 0.50
12	0.010.2669.2	4	con.rod half bushing - mm 0.75

MIT\_H36\_016-A-001

0108A1-002 35CV

**CRANKSHAFT - FLYWHEEL**

Fig.	P/n	QTY	Name
1	0.010.2672.0	1	crankshaft
2	0.009.4555.1	2	key
3	0.009.4554.2	1	flat washer
4	0.009.4555.0	1	spring washer
5	0.009.4554.1	1	nut
6	0.010.2672.2	1	pulley
7	0.010.3954.2	1	flywheel
7.1	0.010.2671.0	1	crown wheel Z=110
7.2	0.000.0000.1		cannot be supplied
8	0.009.4557.0	4	screw
9	0.010.3955.0	1	gear Z = 28
10	0.009.4556.1	1	special bearing

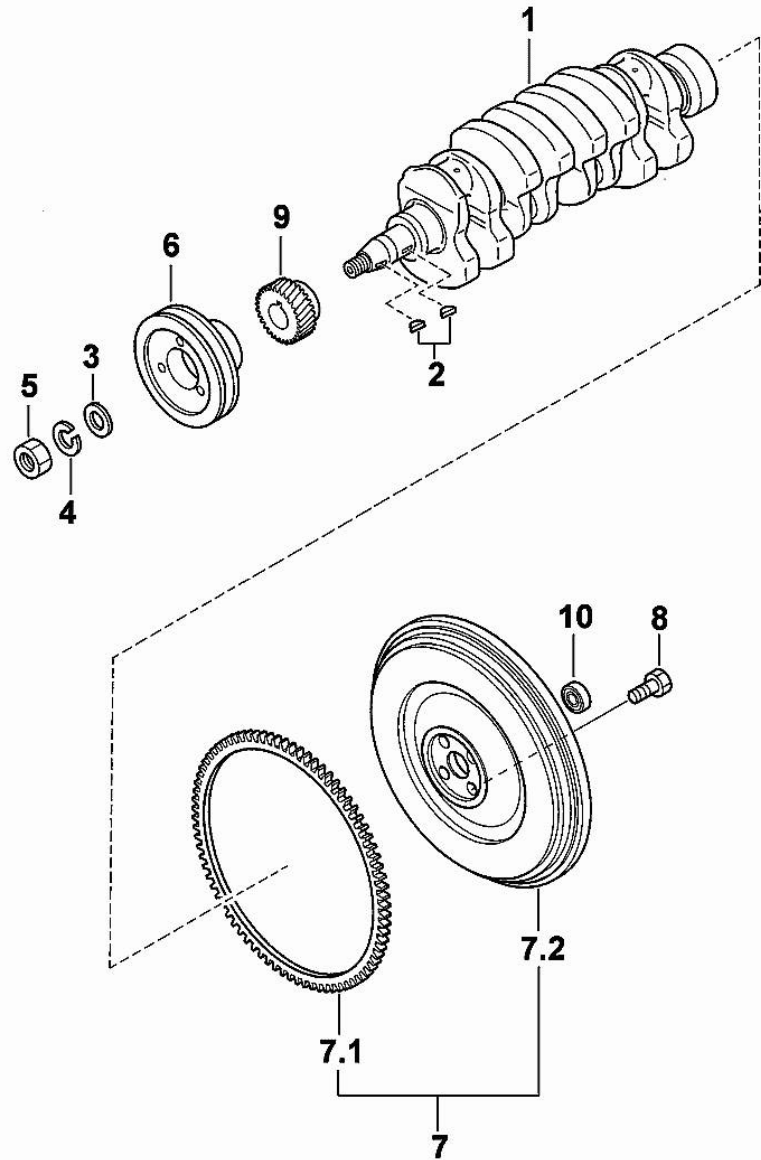

MIT\_H36\_019-A-001

0108B1-021

**CAMSHAFT**

Fig.	P/n	QTY	Name
1	0.010.3955.1	1	gear z=56
2	0.010.3955.2	1	gear z=56
3	0.010.3956.0	1	gear z=39
3.1	0.000.0000.1		cannot be supplied
3.2	0.000.0000.1		cannot be supplied

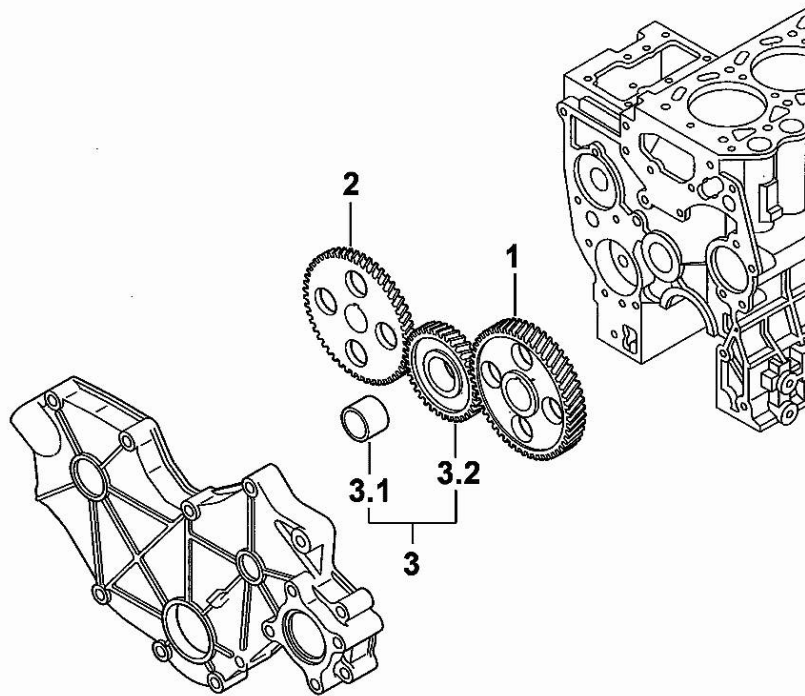

MIT\_H36\_021-A-001

01091-020E

**INTAKE AND EXHAUST**

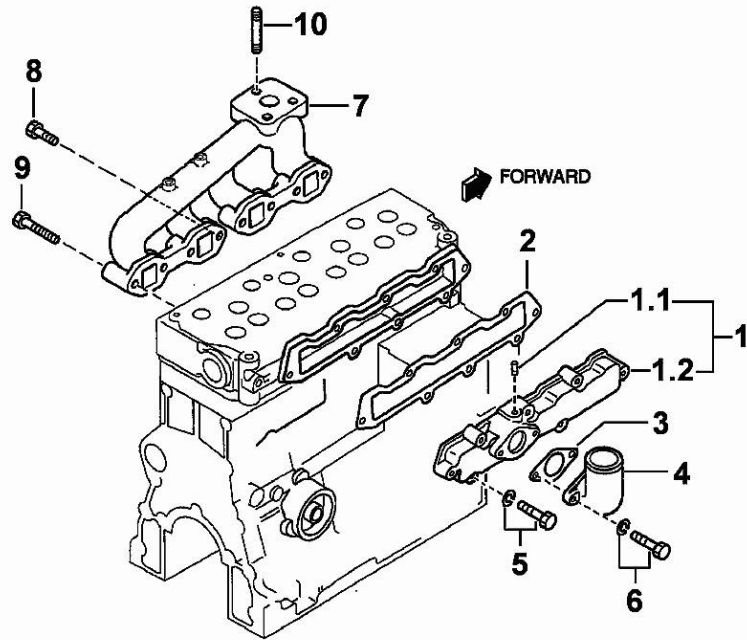

Fig.	P/n	QTY	Name
1	0.010.2678.0	1	cover
1.1	0.000.0000.1		cannot be supplied
1.2	0.000.0000.1		cannot be supplied
2	0.010.2678.1	1	gasket
3	0.010.2676.2	1	gasket
4	0.010.2676.1	1	manifold
5	0.010.2677.0	8	screw
6	0.010.2677.1	2	screw
7	0.010.3956.1	1	exhaust manifold
8	0.010.3956.2	6	screw
9	0.010.3957.0	2	screw
10	0.009.4796.1	3	stud bolt

MIT\_H36\_022-A-001

02011-039E



**Suggest:**

**For more complete manuals. Please go to the home page.**

**<https://www.ebooklibonline.com>**

**If the above button click is invalid. Please download this document first, and then click the above link to download the complete manual.**

**Thank you so much for reading**

**OIL PUMP**

Fig.	P/n	QTY	Name
1	0.010.2684.2	1	oil pump
1.1	0.010.2685.0	1	gasket
2	0.010.2685.1	3	screw

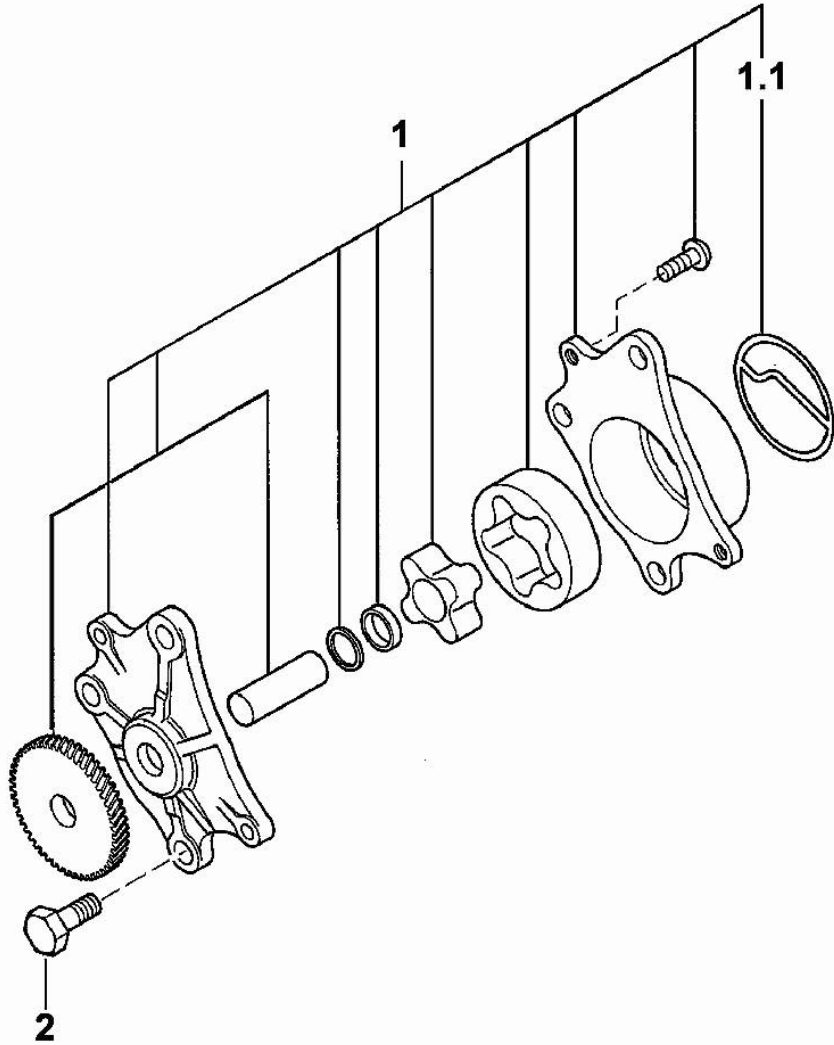

03011-001E

MIT\_H36\_025-A-001

**LUBRICATION**

Fig.	P/n	QTY	Name
1	0.010.2685.2	1	tube
1.1	0.009.4634.0	1	self-locking nut
2	0.009.4634.1	1	gasket

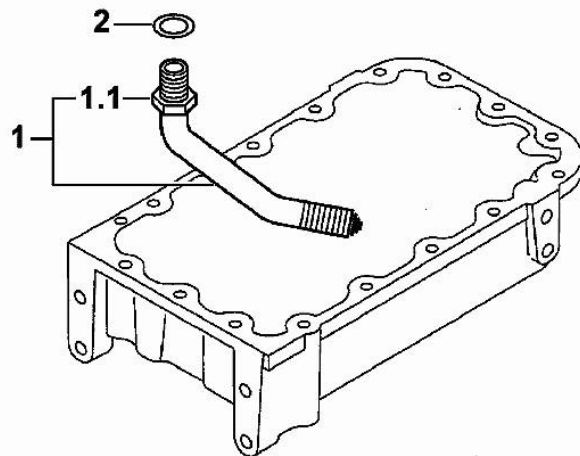
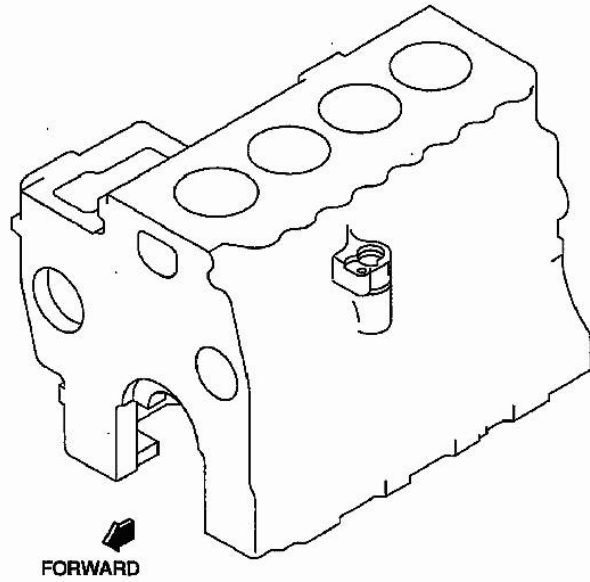

MIT\_H36\_026-A-001

03031-008E

**<https://www.ebooklibonline.com>**

Hello dear friend!

Thank you very much for reading.

Enter the link into your browser.

The full manual is available for immediate download.

**<https://www.ebooklibonline.com>**