

Section: ENGINE
CYLINDER HEAD

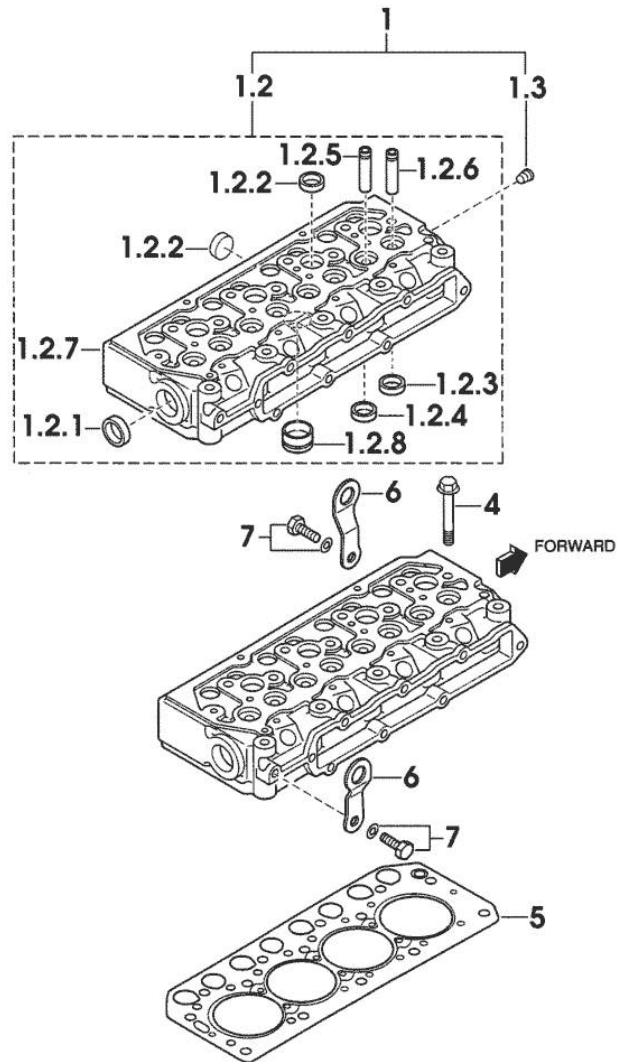

Fig.	P/n	QTY	Name
------	-----	-----	------

Notes:
[PRINCE 30]

1	0.010.3948.1	1	engine head
1.2	0.000.0000.1		cannot be supplied
1.2.1	0.010.2634.1	1	plug
1.2.2	0.009.4527.0	7	plug
1.2.3	0.000.0000.1		cannot be supplied
1.2.4	0.000.0000.1		cannot be supplied
1.2.5	0.010.2634.2	4	valve guide
1.2.6	0.010.2635.0	4	valve guide
1.2.7	0.000.0000.1		cannot be supplied
1.2.8	0.010.2637.1	4	special bushing
1.3	0.009.4545.1	1	plug
4	0.010.2633.1	14	screw
5	0.010.2635.2	1	gasket
6	0.009.4541.2	2	bracket
7	0.010.2633.0	2	screw

01011-001E 35CV

Section: ENGINE
CYLINDER HEAD

Fig.	P/n	QTY	Name
------	-----	-----	------

Notes:
[PRINCE 30]

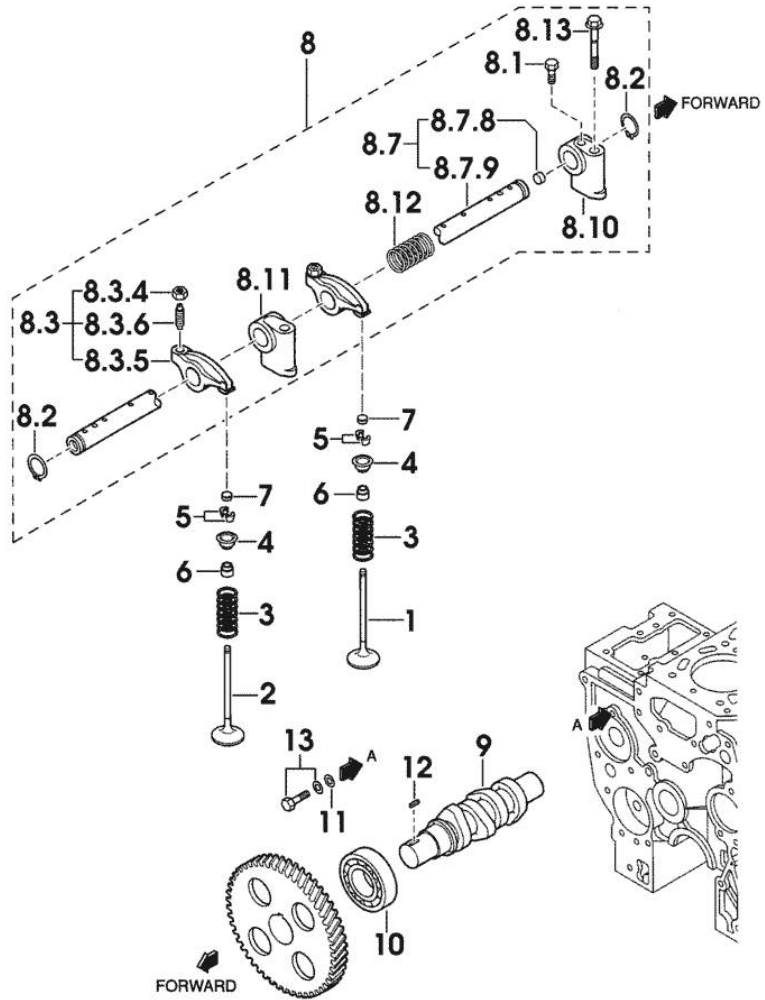

1	0.010.2637.2	4	inlet valve Ø mm 6.5
2	0.010.2638.0	4	exhaust valve Ø mm 6.5
3	0.010.2638.1	8	spring
4	0.010.3992.2	8	cup
5	0.009.4561.2	16	stop
6	0.009.4562.0	8	gasket
7	0.010.2639.0	8	cap
8	0.000.0000.1	1	cannot be supplied
8.1	0.010.2640.1	1	screw
8.2	0.009.4559.0	2	ring
8.3	0.010.3949.0	8	rocker arm
8.3.4	0.010.2641.0	8	nut
8.3.5	0.000.0000.1		cannot be supplied
8.3.6	0.010.3949.1	8	register
8.7	0.010.2644.1	1	shaft
8.7.8	0.010.2643.0	2	plug
8.7.9	0.000.0000.1		cannot be supplied
8.10	0.010.2642.0	1	support
8.11	0.010.2642.1	3	support
8.12	0.010.2643.1	3	spring
8.13	0.010.2643.2	4	screw
9	0.010.2644.0	1	camshaft
10	0.009.4567.0	1	special bearing
11	0.009.4566.0	1	washer
12	0.009.4567.2	1	stick
13	0.010.2639.1	1	screw

01021-013E

Section: ENGINE

CYLINDER HEAD COVER

Fig.	P/n	QTY	Name
------	-----	-----	------

Notes:
[PRINCE 30]

1	0.010.2647.1	1	cover
1.1	0.000.0000.1		cannot be supplied
1.2	0.000.0000.1		cannot be supplied
2	0.010.2647.2	1	gasket
3	0.010.2645.2	5	screw
4	0.009.4548.0	1	plug
5	0.010.2647.0	1	tube

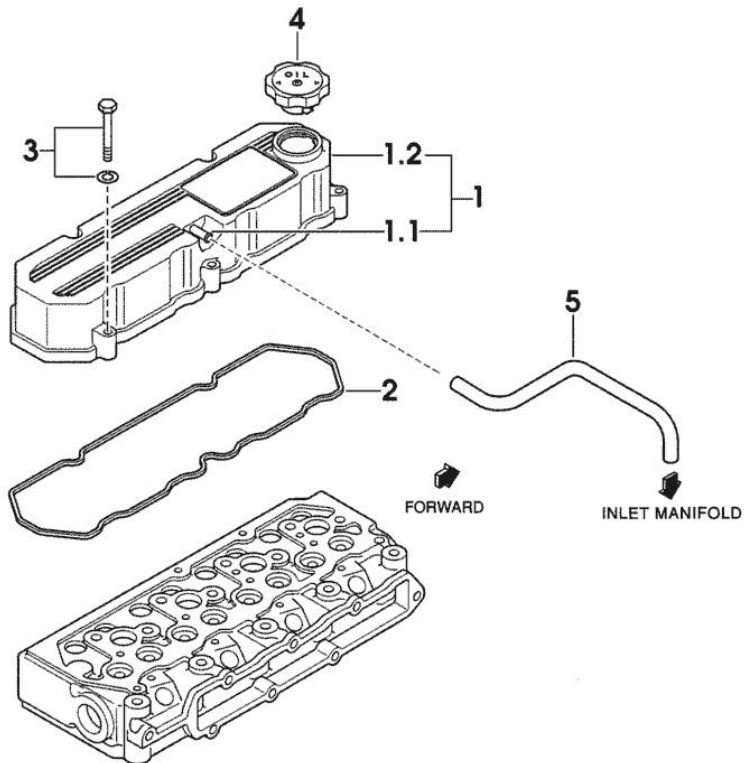

01031-021E

<https://www.ebooklibonline.com>

Hello dear friend!

Thank you very much for reading.

Enter the link into your browser.

The full manual is available for immediate download.

<https://www.ebooklibonline.com>

CAMSHAFT

Fig.	P/n	QTY	Name
------	-----	-----	------

Notes:
[PRINCE 30]

1	0.010.3949.2	1	camshaft
2	0.009.4555.1	1	key
3	0.010.3950.0	1	small plate
4	0.010.2639.1	2	screw
5	0.010.3950.1	8	tappets
6	0.010.2646.2	8	rod

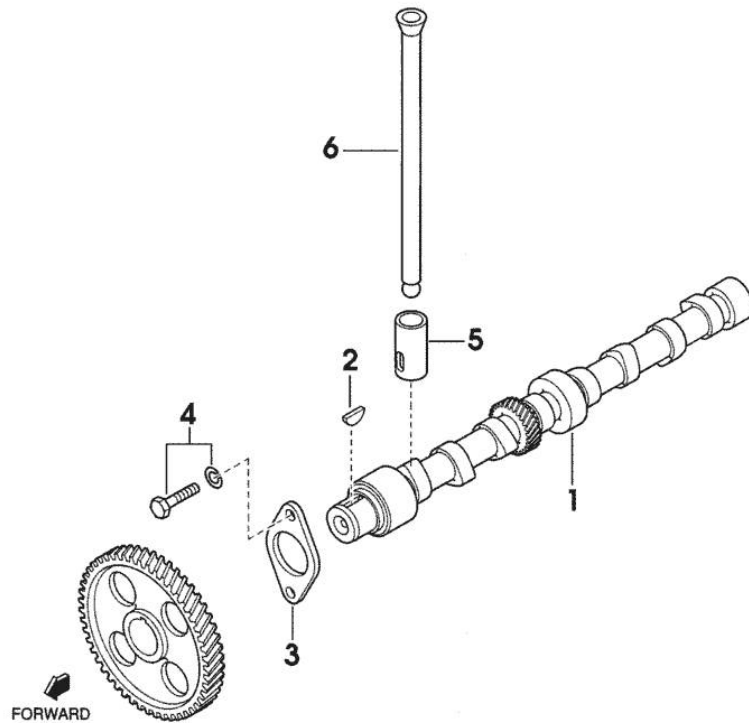

01031-016E

Section: ENGINE
CRANKCASE

Fig.	P/n	QTY	Name
------	-----	-----	------

Notes:
 [PRINCE 30]

1	0.010.3950.2	1	crankcase
1.2	0.000.0000.1		cannot be supplied
1.2.1	0.010.2652.1	3	special bushing
1.2.2	0.010.2652.2	3	special bushing
1.2.3	0.010.2653.0	10	screw
1.2.4	0.010.2653.1	1	special bushing
1.2.5	0.000.0000.1		cannot be supplied
1.2.5.6	0.000.0000.1		cannot be supplied
1.2.5.7	0.000.0000.1		cannot be supplied
1.2.5.8	0.000.0000.1		cannot be supplied
1.2.5.9	0.000.0000.1		cannot be supplied
1.2.5.10	0.000.0000.1		cannot be supplied
1.2.11	0.000.0000.1		cannot be supplied
1.3	0.009.4523.2	1	guide
1.4	0.010.2649.0	1	plug
1.5	0.010.2649.1	3	special bushing
1.6	0.009.4545.1	1	plug
1.7	0.009.4524.2	4	special bushing
1.8	0.009.4525.1	2	special bushing
1.9	0.009.4525.2	1	special bushing
1.10	0.009.4524.1	1	expansion plug
1.11	0.010.3951.0	1	pin
1.12	0.009.4523.0	2	pin
1.13	0.010.2650.0	1	pin
1.13.1	0.000.0000.1	1	cannot be supplied
1.13.2	0.000.0000.1	1	cannot be supplied
1.15	0.010.2651.0	2	pin
1.16	0.010.2651.1	1	plug
1.17	0.010.2648.2	1	plug
18	0.010.2648.1	4	screw
19	0.010.2650.2	1	pipe fitting
20	0.010.2651.2	4	gasket

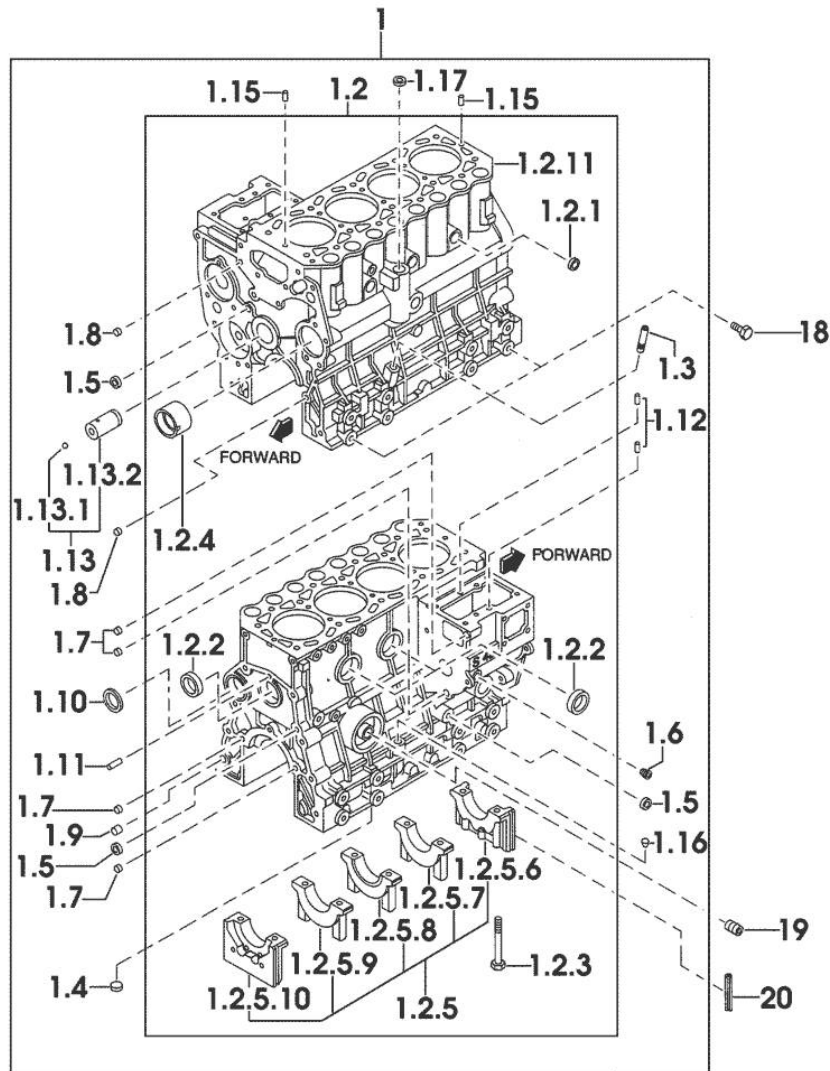

01041-048E

Section: ENGINE

MAIN BEARINGS

Fig.	P/n	QTY	Name
------	-----	-----	------

Notes:
[PRINCE 30]

1	0.009.4530.0	1	plug
2	0.009.4531.0	1	main half bushing STANDARD
3	0.009.4531.1	1	main half bushing - mm 0.25
4	0.009.4531.2	1	main half bushing - mm 0.50
5	0.009.4532.0	1	main half bushing - mm 0.75

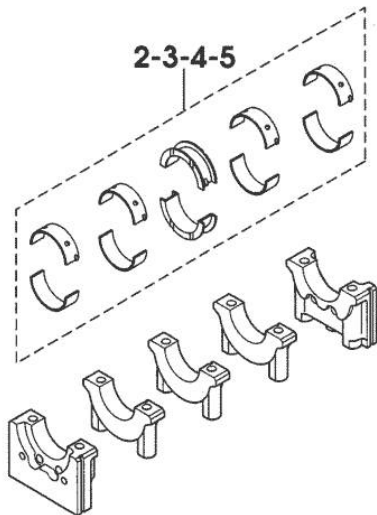
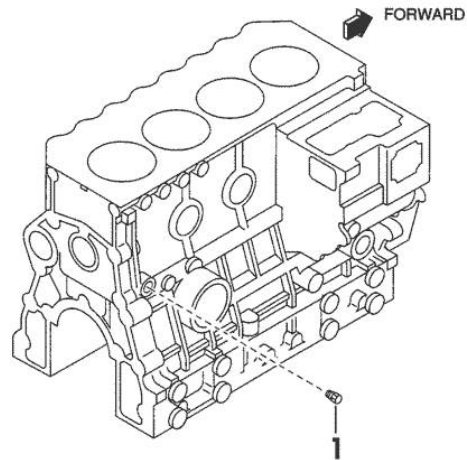

0104B1-003E

Section: ENGINE
TIMING CASE

Fig.	P/n	QTY	Name
------	-----	-----	------

Notes:
[PRINCE 30]

1	0.010.2658.0	1	plate
2	0.010.2658.1	1	gasket
3	0.010.2639.1	10	screw
4	0.010.3951.1	1	flange
5	0.010.2659.0	1	gasket
6	0.010.2659.1	8	screw
7	0.009.4537.0	1	gasket
8	0.010.3951.2	1	plug
9	0.010.2660.0	1	flange
10	0.010.2660.1	1	gasket
11	0.009.4756.0	2	cover
12	0.010.3952.0	2	gasket
13	0.010.2661.0	1	screw
14	0.010.2661.1	2	nut
15	0.010.3952.1	1	screw
16	0.010.3952.2	2	screw
17	0.009.4539.2	2	spring washer
18	0.010.3953.0	1	cover
19	0.010.2662.2	4	screw
20	0.010.2663.0	4	washer

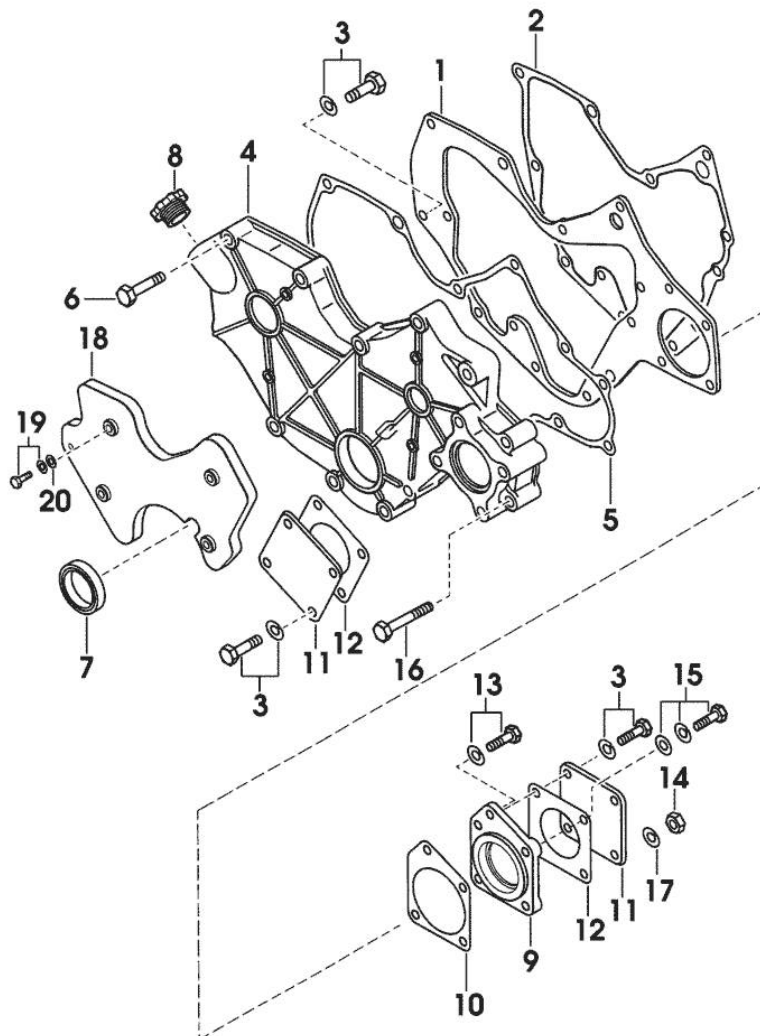

01051-018

FLYWHEEL HOUSING

Fig.	P/n	QTY	Name
------	-----	-----	------

Notes:
[PRINCE 30]

1	0.010.2654.2	1	flange
2	0.010.2655.0	1	gasket
3	0.010.2655.1	1	special oil seal
4	0.010.2655.2	5	screw
5	0.010.3953.1	1	flange
6	0.009.4532.2	1	pin
7	0.010.3953.2	10	screw

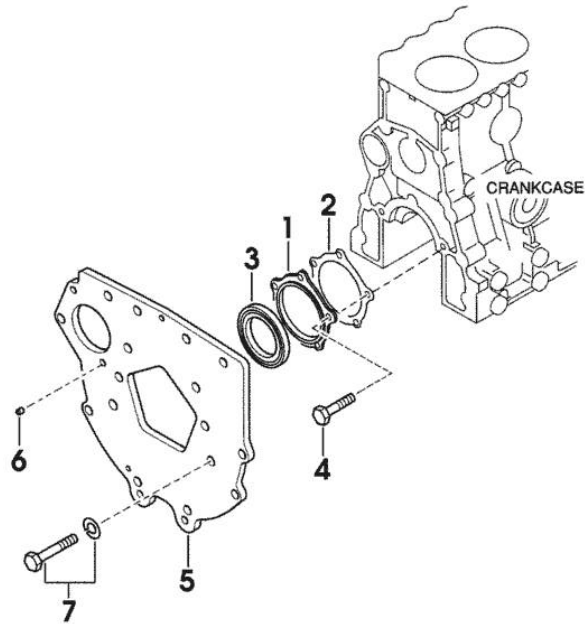

01061-019E

OIL PAN

Fig.	P/n	QTY	Name
------	-----	-----	------

Notes:
[PRINCE 30]

1	0.010.3954.0	1	oil sump
1.1	0.010.2664.0	1	plug
1.2	0.010.2663.2	1	gasket
1.3	0.000.0000.1		cannot be supplied
2	0.010.3954.1	12	screw
3	0.010.2664.2	1	screw
4	0.010.2665.0	4	screw
5	0.010.2665.1	5	washer
6	0.010.2687.1	1	dipstick

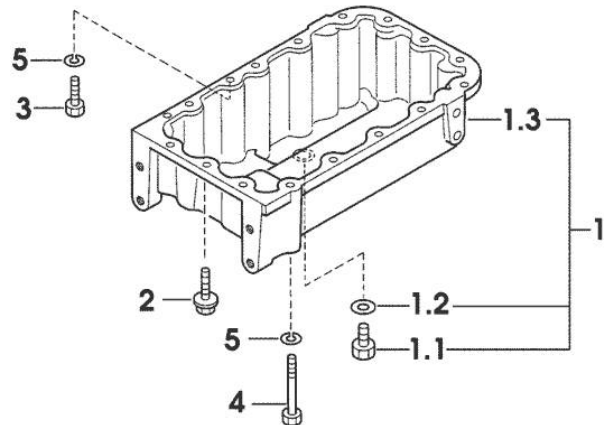
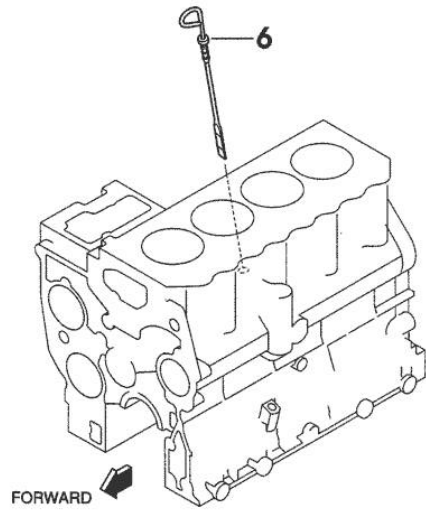

01071-038E



Suggest:

For more complete manuals. Please go to the home page.

<https://www.ebooklibonline.com>

If the above button click is invalid. Please download this document first, and then click the above link to download the complete manual.

Thank you so much for reading

Section: ENGINE

PISTON - CONNECTING ROD

Fig.	P/n	QTY	Name
------	-----	-----	------

Notes:
[PRINCE 30]

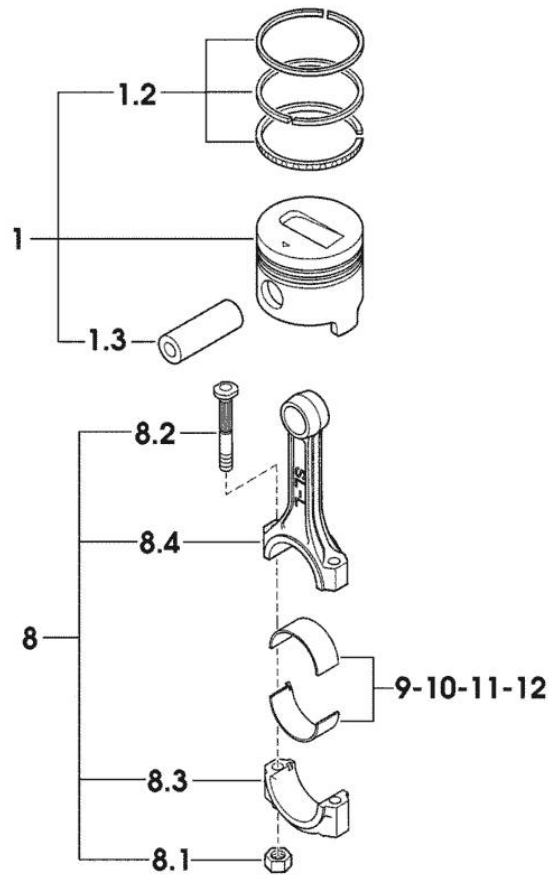

1	0.007.0060.6	4	complete piston STANDARD
1	0.007.0061.6	4	complete piston + mm 0.25
1	0.007.0062.6	4	complete piston + mm 0.50
1.2	0.008.0052.6	4	piston ring set STANDARD
1.2	0.008.0053.6	4	piston ring set + mm 0.25
1.2	0.008.0054.6	4	piston ring set + mm 0.50
1.3	0.010.2668.0	4	piston pin
8	0.010.2671.2	4	engine connecting rod
8.1	0.009.4783.0	8	nut
8.2	0.010.2668.2	8	screw
8.3	0.000.0000.1		cannot be supplied
8.4	0.000.0000.1		cannot be supplied
9	0.009.4782.1	4	con.rod half bushing STANDARD
10	0.010.2669.0	4	con.rod half bushing - mm 0.25
11	0.010.2669.1	4	con.rod half bushing - mm 0.50
12	0.010.2669.2	4	con.rod half bushing - mm 0.75

0108A1-002 35CV

CRANKSHAFT - FLYWHEEL

Fig.	P/n	QTY	Name
------	-----	-----	------

Notes:
[PRINCE 30]

1	0.010.2672.0	1	crankshaft
2	0.009.4555.1	2	key
3	0.009.4554.2	1	flat washer
4	0.009.4555.0	1	spring washer
5	0.009.4554.1	1	nut
6	0.010.2672.2	1	pulley
7	0.010.3954.2	1	flywheel
7.1	0.010.2671.0	1	crown wheel Z=110
7.2	0.000.0000.1	1	cannot be supplied
8	0.009.4557.0	4	screw
9	0.010.3955.0	1	gear Z = 28
10	0.009.4556.1	1	special bearing

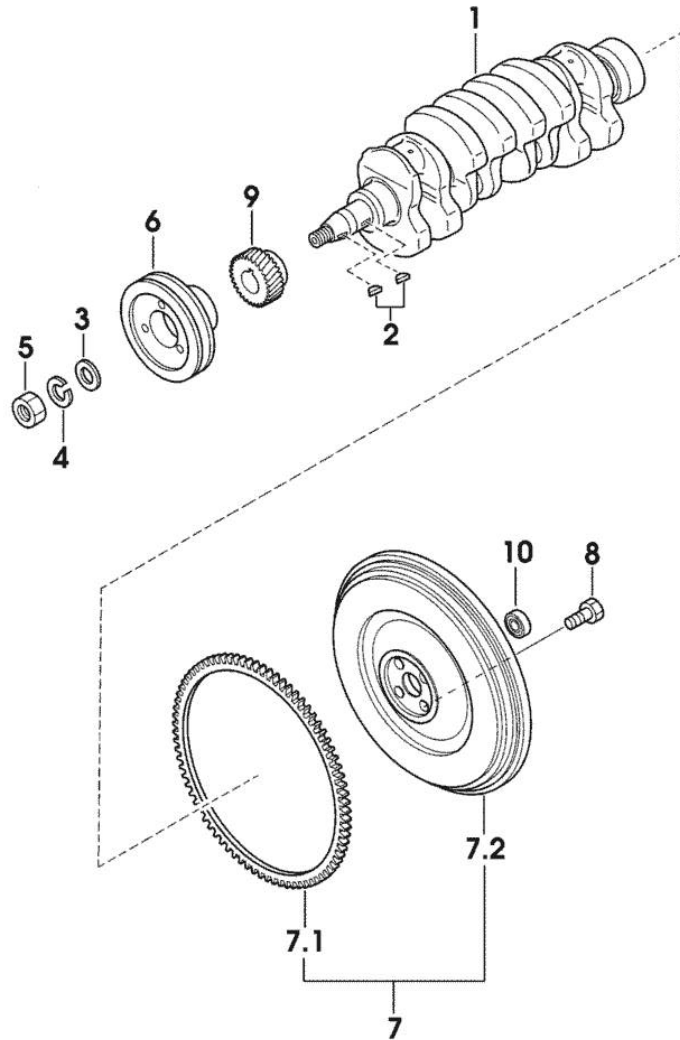

0108B1-021

<https://www.ebooklibonline.com>

Hello dear friend!

Thank you very much for reading.

Enter the link into your browser.

The full manual is available for immediate download.

<https://www.ebooklibonline.com>