

Section: ENGINE
CRANKCASE

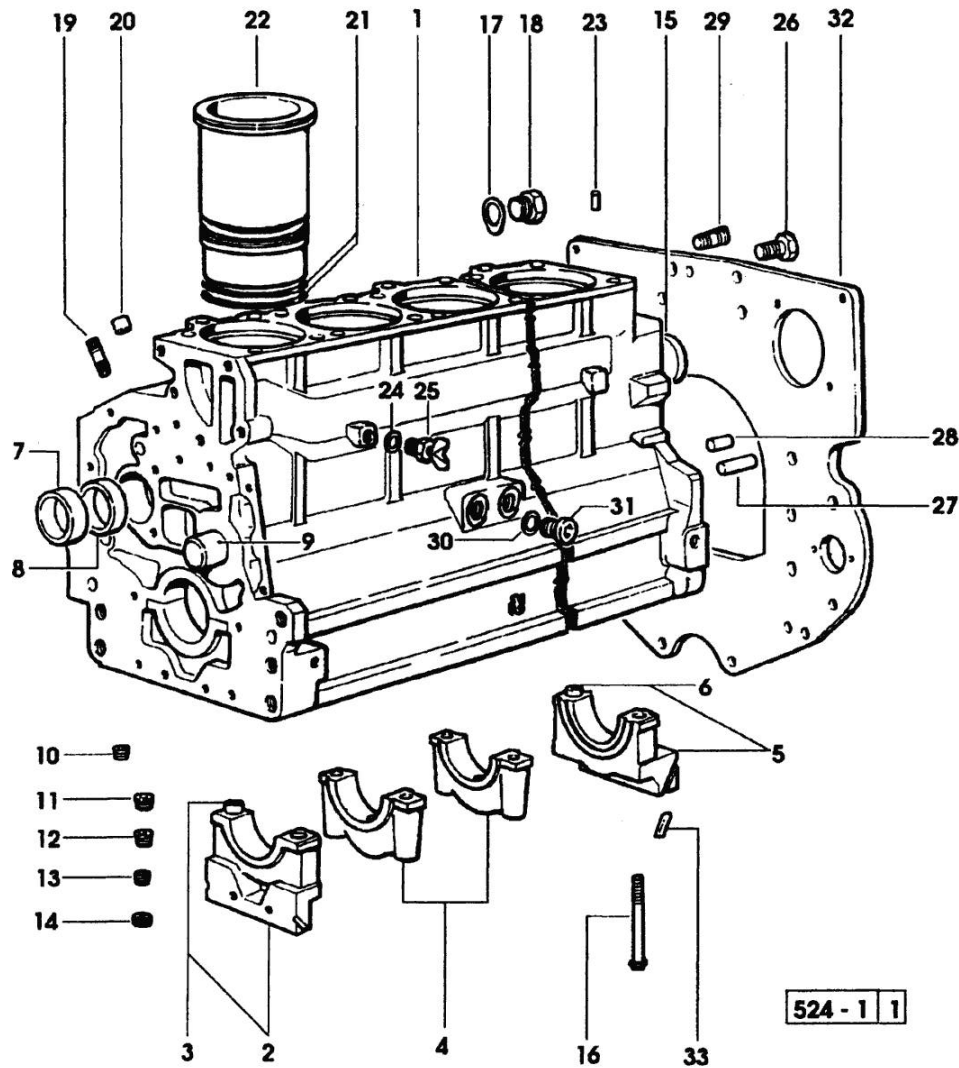
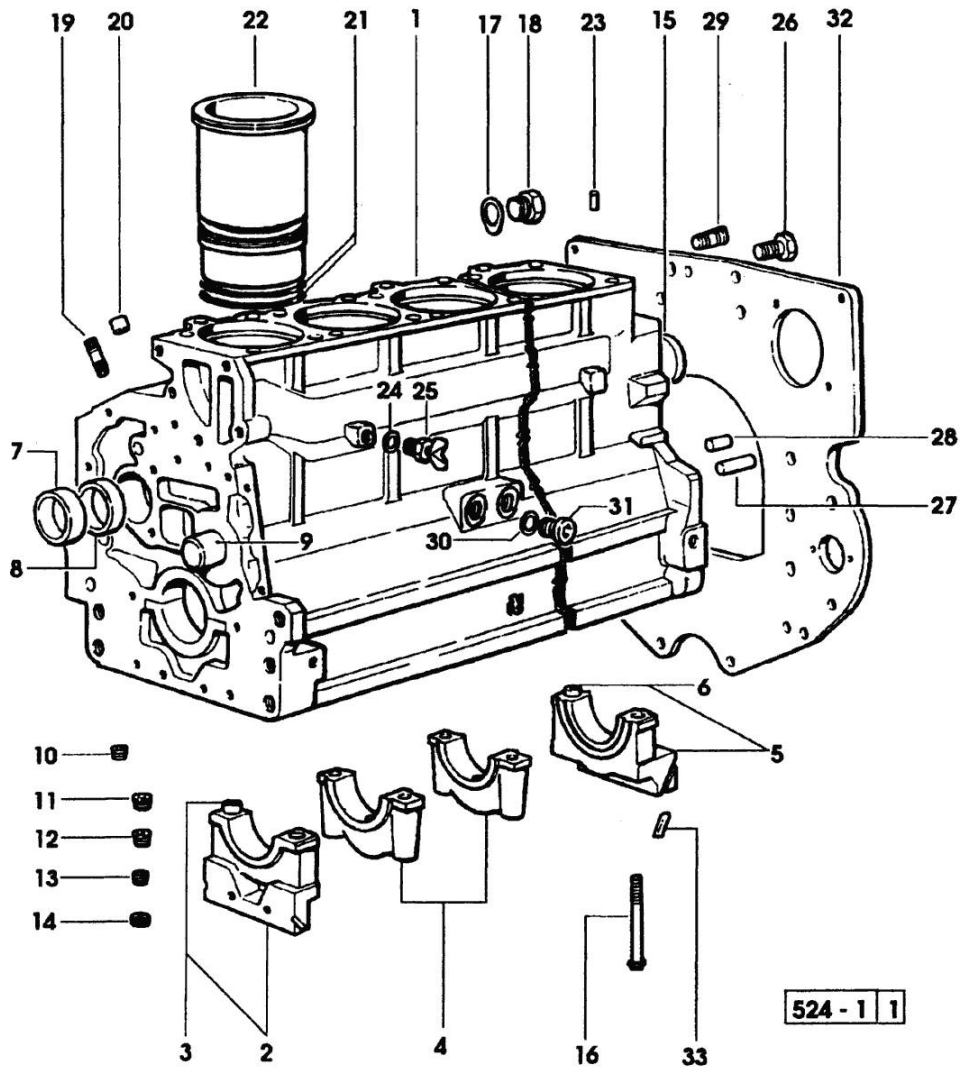

Fig.	P/n	QTY	Name
Notes: [H 6115 ELITE]			
0	0.337.0050.6	1	gasket set - FOR ENGINE MOUNTING
1	0.007.1102.6	1	crankcase =>1170 X H 6115 ELITE =>1151 X H 6135 ELITE
1	0.078.1110.6	1	crankcase 1169<= X H 6115 ELITE 1150<= X H 6135 ELITE
2	0.065.1112.3	1	support
3	2.1699.165.0	1	bush 12.3x15x16
4	0.065.1114.0/10	5	support
5	0.007.0848.3/10	1	support =>1170 X H 6115 ELITE =>1151 X H 6135 ELITE
5	0.065.1116.3	1	support 1169<= X H 6115 ELITE 1150<= X H 6135 ELITE
6	2.1699.165.0	1	bush 12.3x15x16
7	0.065.1141.0	1	special bushing 59X55X30
8	0.065.1140.0	6	special bushing 59X55X20
9	0.066.1151.0	1	pin
10	2.3130.001.1	14	plug 1/8" gas
11	2.3130.002.1	2	plug 1/4" gas
12	2.3130.003.1	7	plug 3/8" gas
13	2.3131.006.0	1	plug m 22 x 1.5
14	2.1324.011.0	1	plug
15	2.3179.012.0	1	plug 60
16	0.065.1117.0	14	screw m 12 x 100
17	2.1539.047.0	1	special oil seal 26.7x1.78
18	2.3199.405.2	1	plug m 28 p.1.5
19	2.0432.003.7	18	stud bolt m 8 p.1.25 / p.1 x 20
20	2.1559.188.0/10	6	bush
21	2.1519.096.0/20	12	special oil seal 107.67x1.78
22	0.088.1120.0/20	6	engine cylinder
23	2.1549.154.2	6	bush 4.8x5.8x16
24	2.1560.009.0	1	gasket 14.2x18
25	0.049.1152.0	1	cock
26	2.0112.511.1	8	screw m 14 p.2 x 30
27	2.1651.912.0	2	cylindrical plug 12x28
28	2.1651.917.0	1	cylindrical plug 12x40
29	2.0432.255.7	2	stud bolt m 12 p.1.75-1.25x25

Section: ENGINE
CRANKCASE

Fig.	P/n	QTY	Name
30	2.1560.017.0	1	gasket 22.2 x 27
31	2.3120.002.4	1	plug m 22 x 1.5
32	0.007.0805.0/10	1	flange 1289<= X H 6115 ELITE 1273<= X H 6135 ELITE
32	0.007.0805.0/20	1	flange =>1290 X H 6115 ELITE =>1274 X H 6135 ELITE
33	0.066.1152.0/10	4	gasket



Section: ENGINE

TIMING CASE

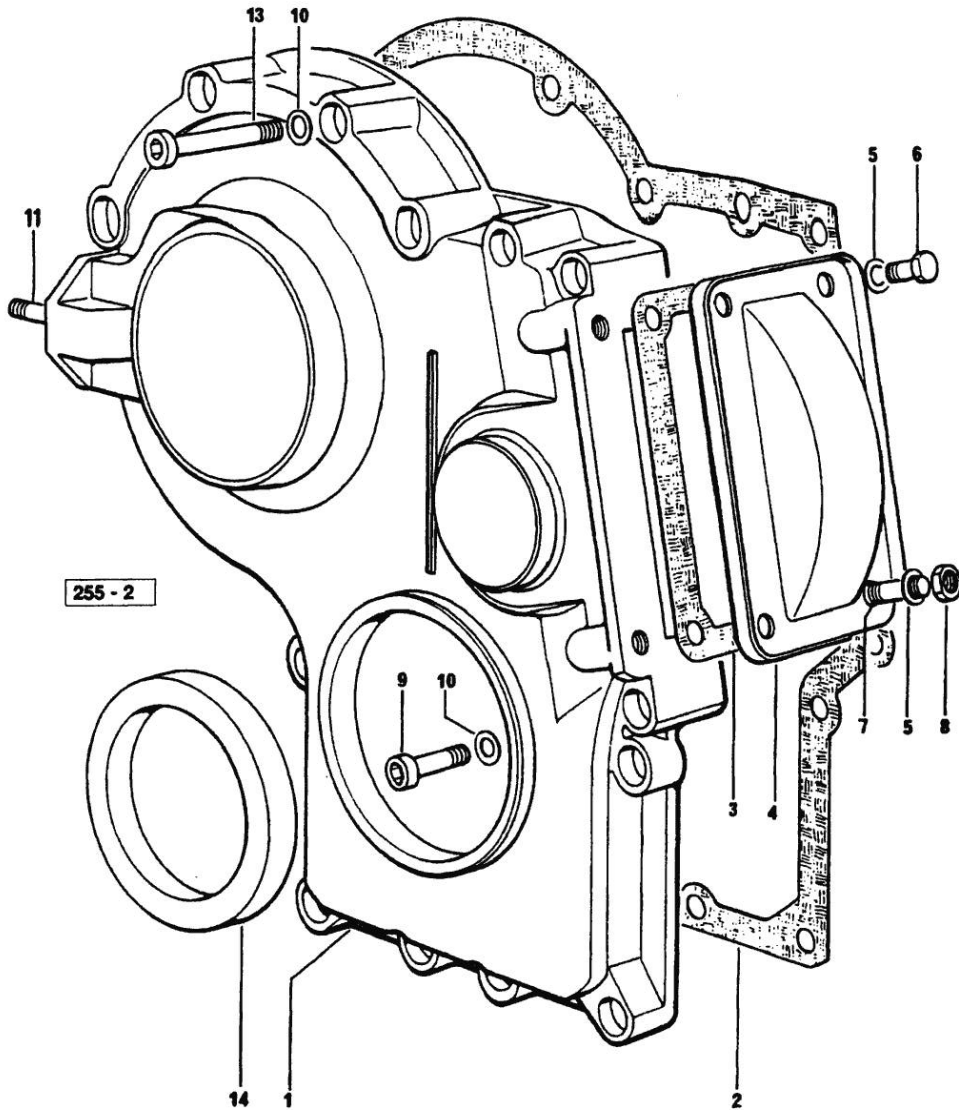

Notes:
[H 6115 ELITE]

Fig.	P/n	QTY	Name
1	0.065.1132.0/20	1	guard
2	0.065.1150.0/20	1	gasket
3	0.065.1152.0	1	gasket
4	0.065.1151.0	1	cover
5	2.1470.004.2	4	lock washer 8
6	2.0112.205.2	2	screw m 8 p.1.25 x 16
7	2.0432.003.7	2	stud bolt m 8 p.1.25 / p.1 x 20
8	2.1011.405.2	2	nut m 8 p.1
9	2.0312.214.1	3	screw m 8 p.1.25 x 40
10	2.1480.014.1	15	washer 8
11	2.0432.003.7	2	stud bolt m 8 p.1.25 / p.1 x 20
13	2.0312.208.2	8	screw m 8 p.1.25 x 25
13	2.0312.219.2	4	screw m 8 p.1.25x65
14	2.1529.108.0	1	special oil seal 70x90x10

<https://www.ebooklibonline.com>

Hello dear friend!

Thank you very much for reading.

Enter the link into your browser.

The full manual is available for immediate download.

<https://www.ebooklibonline.com>



 Section: ENGINE
CRANKSHAFT

Fig.	P/n	QTY	Name
Notes:			
[H 6115 ELITE]			
1	0.006.5605.3	1	crankshaft 1169<=
1	0.006.5605.3/30	1	crankshaft =>1170
1	0.007.0855.0	1	gear =>1170
2	2.1652.915.0	1	cylindrical plug 12x35
3	0.065.1215.0	7	main half bushing STANDARD
3	0.065.1215.7	7	main half bushing - mm 0.25
3	0.065.1215.8	7	main half bushing - mm 0.50
4	0.065.1216.0	7	main half bushing
4	0.065.1216.7	7	main half bushing - mm 0.25
4	0.065.1216.8	7	main half bushing - mm 0.50
5	0.065.1218.0	4	shim STANDARD
5	0.065.1218.7	4	shim + mm 0.10
5	0.065.1218.8	4	shim + mm 0.15
6	2.1599.524.7	1	washer 21x60x12
7	2.1720.006.0	1	key 4x6.5
8	0.007.1010.3	1	antivibration pulley
9	0.065.1254.0/10	1	gasket
10	0.007.0851.0	1	cover =>1170
10	0.065.1253.0/10	1	cover 1169<=
11	2.1529.073.0	1	special oil seal 110x130x13
12	2.1474.009.2	9	spring washer 8
13	2.0112.207.2	9	screw m 8 p 1.25 x 20
14	0.008.4049.3	1	flywheel mm 373
14	0.065.1242.0	1	crown wheel Z = 123
15	0.288.3625.0	1	flange
16	2.0139.023.2	6	screw
17	0.007.0962.0/20	1	pulley
18	2.1589.137.0	2	shoulder ring 71x110x1
19	2.1470.006.2	6	lock washer 10
20	2.0112.322.2	6	screw m 10 p.1.5x65
21	0.078.1220.3/10	6	engine connecting rod - X 1000.4 W
22	2.0139.021.0	2	screw
23	2.1559.114.0/10	1	special bushing
24	0.065.1225.0	12	con.rod half bushing STANDARD - A = 28.75 -> 29.00
24	0.065.1225.7	12	con.rod half bushing - mm 0.25
24	0.065.1225.8	12	con.rod half bushing - mm 0.50

Section: ENGINE
CRANKSHAFT

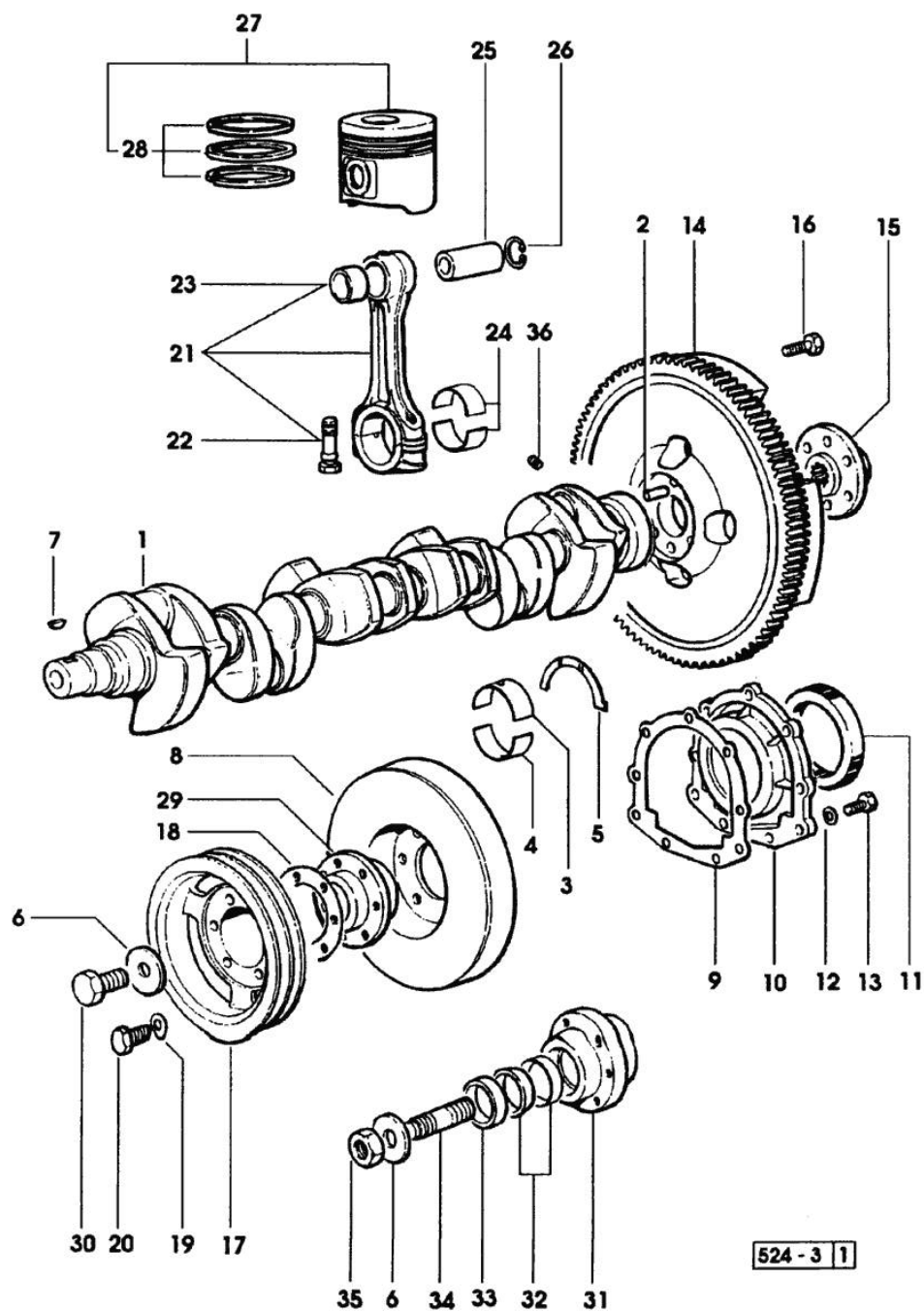
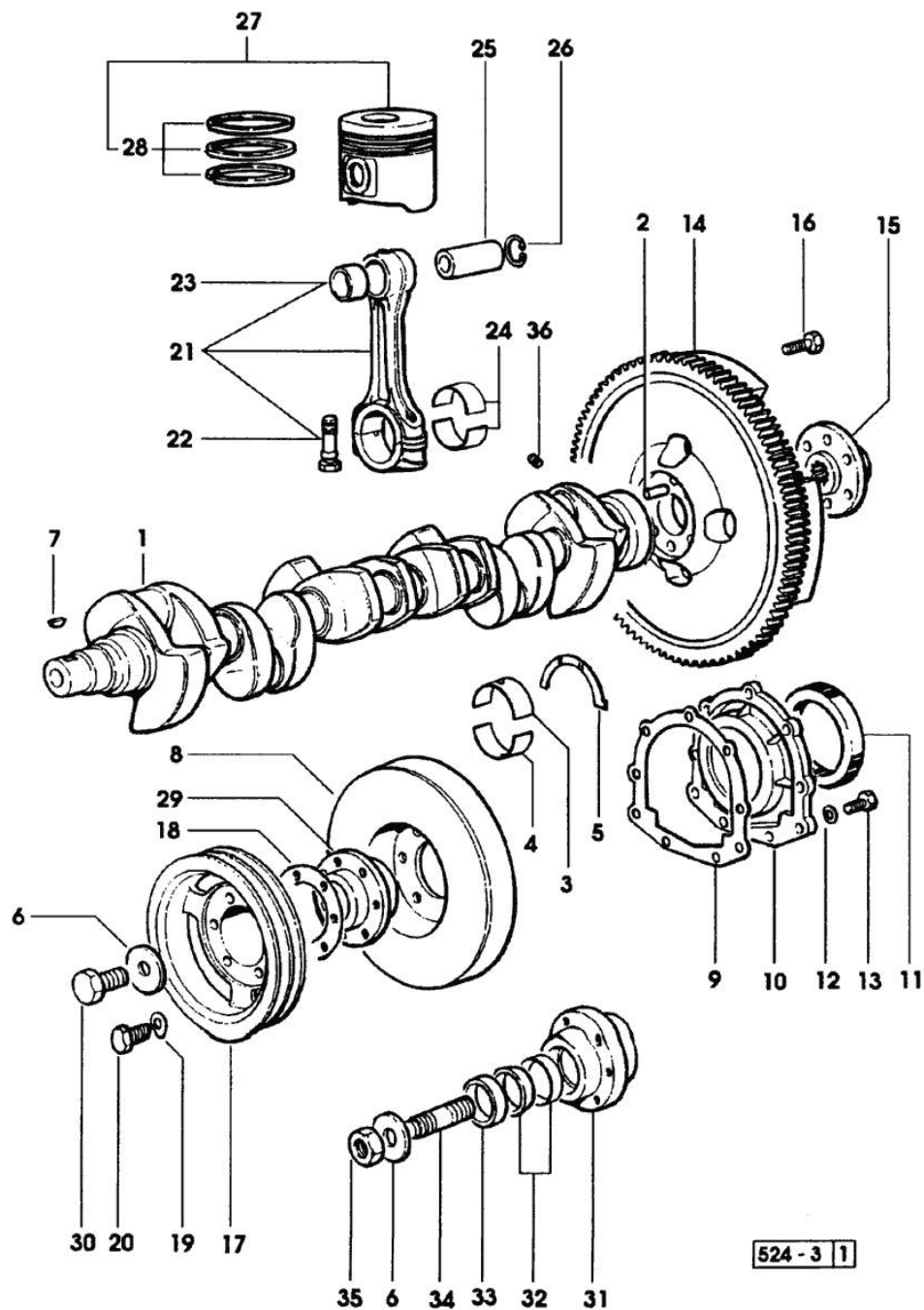

Fig.	P/n	QTY	Name
25	0.078.1236.0	6	piston pin Ø 18 / Ø 35 / L = mm 86
26	2.1411.014.1	12	circlip 35
27	0.086.0060.6/10	6	complete piston
28	0.086.0052.6	1	piston ring set
29	0.007.0896.0/10	1	hub 1169<=
29	0.007.1187.0	1	hub =>1170
30	2.0399.144.7	1	screw m 20 p.1.5x51
31	0.007.0894.0/10	1	hub 1169<=
31	0.007.1014.0	1	hub =>1170 FOR FRONT PTO
32	0.035.1263.0	2	ring =>1170
32	0.065.1256.0	2	ring 45x52 1169<=
33	2.1579.865.0	1	spacer 45.2x51.8x10 1169<=
33	2.1579.949.0	1	ring 50.2x56.8x8 =>1170
34	2.0439.195.7	1	stud bolt m 20 p.1.5x80
35	2.1019.094.7	1	nut m 20 p.1.5
36	2.3130.001.1	6	plug 1/8" gas

Section: ENGINE

CAMSHAFT

Fig.	P/n	QTY	Name
------	-----	-----	------

Notes:
[H 6115 ELITE]

1	0.065.1324.0/10	1	gear Z = 32
1	0.075.1310.3/20	1	camshaft
2	0.065.1353.0	1	small plate
3	2.0312.205.2	2	screw
4	2.1480.014.1	2	washer 8
5	0.007.1188.0	1	gear =>1170 X H 6115 ELITE =>1151 X H 6135 ELITE
5	0.065.1323.0/20	1	gear Z = 29 1169<= X H 6115 ELITE 1150<= X H 6135 ELITE
6	0.007.1177.3	1	gear =>(…) WITH RED IDENTIFICATION TAG
6	0.007.1178.3	1	gear =>(…) WITH YELLOW IDENTIFICATION TAG
6	0.007.1179.3	1	gear =>(…) WITH GREEN IDENTIFICATION TAG
6	065.1325.3/20	1	- (…)<=
6	2.1559.185.0/10	1	bushing
7	0.065.1351.0	2	shoulder ring
8	0.065.1352.0	1	shim
9	2.1410.016.1	1	circlip 40
10	0.065.1354.0/10	1	gear z=58
11	0.065.1350.0	1	small disc
12	2.0132.207.2	4	screw m 10 p.1 x 25
13	0.065.1330.0	12	tappets
14	2.1569.114.0/10	24	gasket 14x18.5x8
15	2.1599.437.0	12	shoulder ring
16	2.4019.300.1	12	spring
17	0.065.1332.0	12	sleeve
18	0.065.1331.2	12	rod

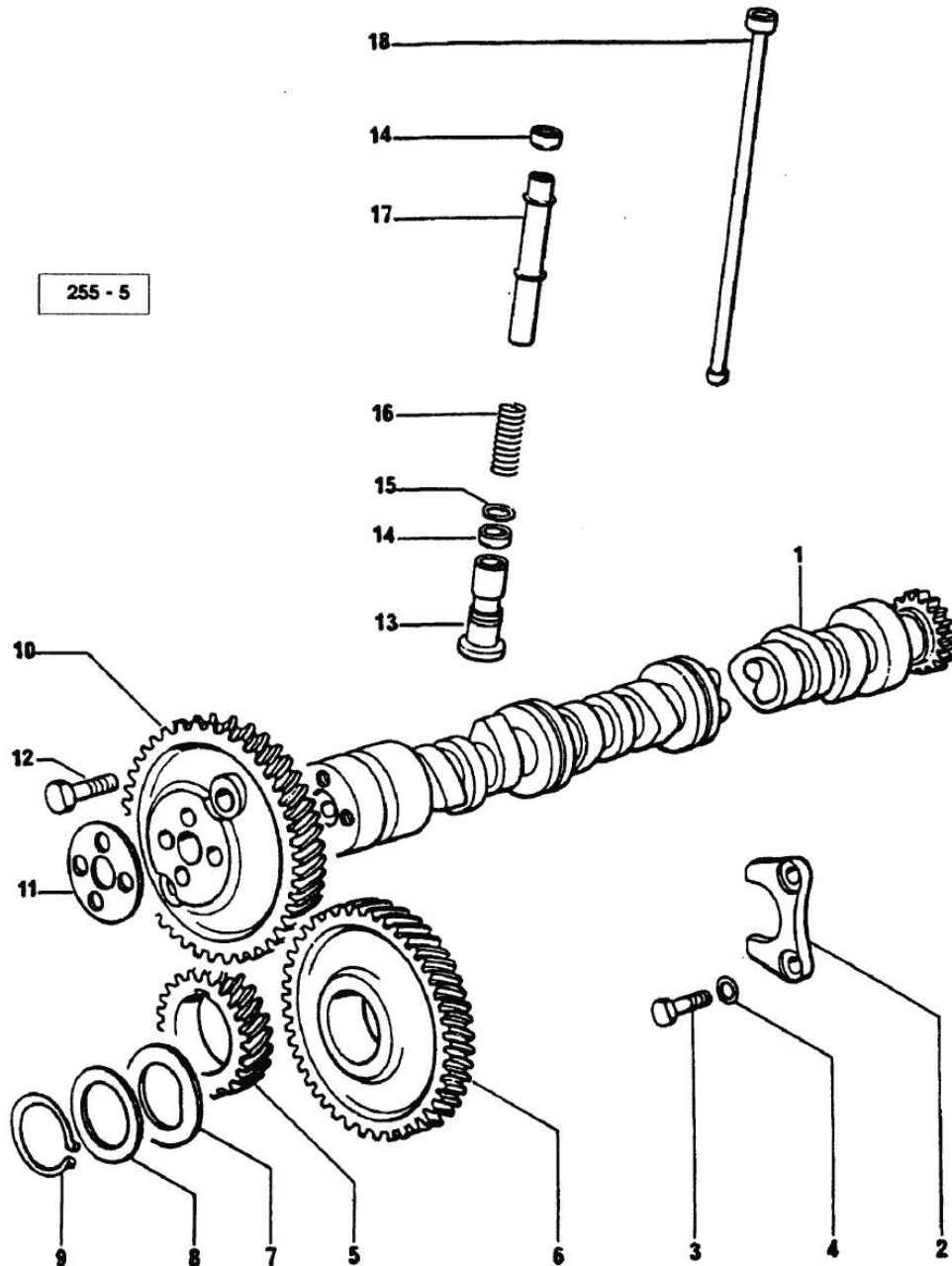

Section: ENGINE
CYLINDER HEAD

Fig.	P/n	QTY	Name
Notes:			
[H 6115 ELITE]			
1	2.0432.011.7	6	stud bolt m 8 p.1.25 / p.1 x 40
2	2.0432.161.7	6	stud bolt m 10 p.1.5 / p.1.25 x 40
3	0.075.1452.0/10	1	sleeve
4	0.078.1420.0	6	inlet valve X H 6115 ELITE
4	0.081.1420.0	6	inlet valve Ø mm 9 X H 6135 ELITE
5	0.066.1421.0	6	exhaust valve
6	0.074.1423.0	12	conical valve cotter
7	0.066.1425.0	12	cup
8	2.4019.287.0	12	spring
9	0.066.1443.0/10	24	screw
10	0.066.1432.0	6	rocker arm
11	0.066.1430.0	6	support
12	2.1599.432.0	12	shoulder ring
13	2.1410.055.1	12	circlip 19
14	2.0432.163.7	6	stud bolt m 10 p.1.5 / p.1.25 x 45
15	2.1011.421.2	12	nut m 10 p.1.25
16	0.021.1434.0	12	screw
17	2.1011.405.2	12	nut m 8 p.1
18	0.078.1440.3	1	cover
18	2.3171.008.4	1	plug 20
19	2.6859.091.0	2	clamp
20	2.0399.130.2	6	screw m 8 x 30
21	2.1539.073.0	6	special oil seal 14x1.78
22	0.078.1451.0/30	6	gasket "A"
22	0.078.1452.0/20	6	gasket "B"
22	0.078.1453.0/30	6	gasket "C"
23	0.078.1450.3	1	cover
24	2.0432.005.7	6	stud bolt m 8 p.1.5 / p.1 x 25
25	0.078.1410.3/60	6	engine head
26	0.066.1416.0	12	valve guide
27	0.066.1427.0	6	valve seat
28	0.078.1426.0	6	valve seat
29	0.066.1413.0	6	bush
30	2.3170.012.1	12	expansion plug 30
31	0.066.1431.0	6	pin
32	2.1559.021.0/40	6	bushing 15x19x22
33	2.1530.056.0	6	oil seal 21.82 x 3.53
34	0.069.1450.0/20	2	gasket

Section: ENGINE
LUBRICATION 1169<=

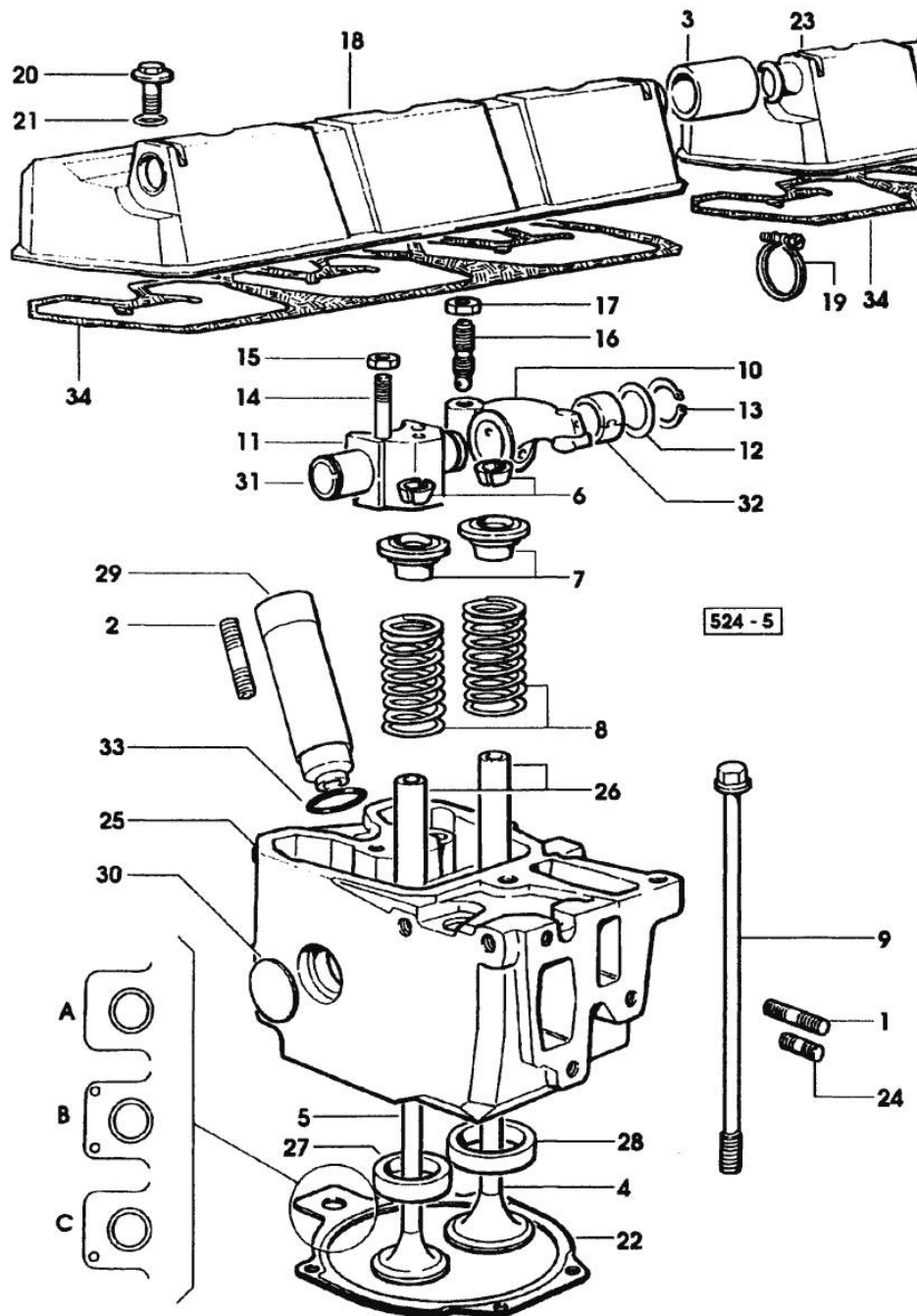
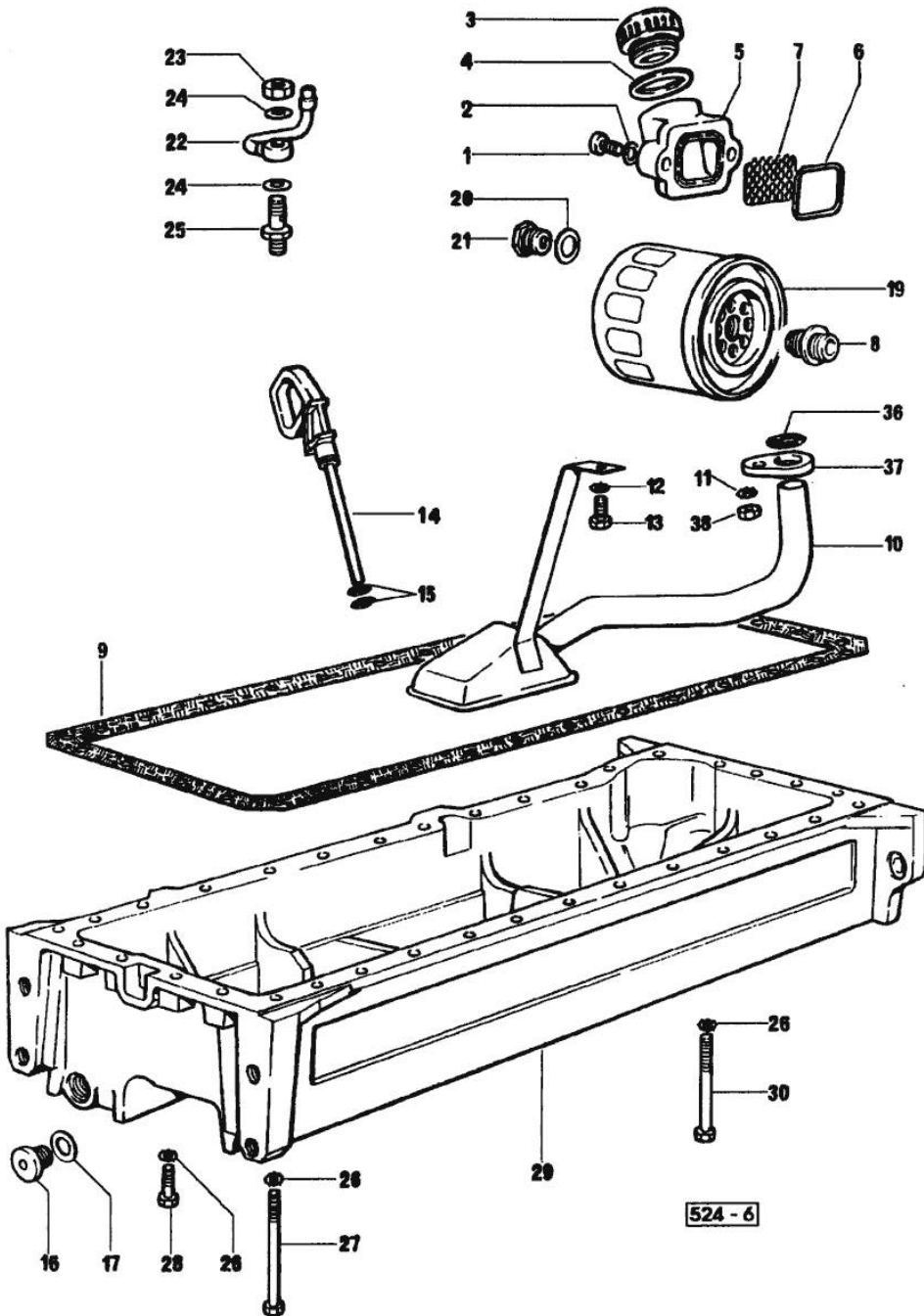

Fig.	P/n	QTY	Name
------	-----	-----	------

Notes:
 [H 6115 ELITE]

1	2.0312.205.2	2	screw
2	2.1480.014.1	2	washer 8
3	0.041.1135.4	1	plug 1" gas
4	2.1569.072.0	1	gasket 32 x 39.5 x 2
5	0.065.1565.0/10	1	pipe union
6	2.1539.042.0	1	special oil seal 47.35x1.78
7	0.065.1567.0/10	1	filter
8	2.3339.307.0	2	pipe fitting m 22 p.1.5-3/4"
9	0.075.1512.0	1	gasket
10	0.007.0880.3	1	tube
11	2.1470.004.2	1	lock washer 8
12	2.1470.004.2	1	lock washer 8
13	2.0112.205.2	1	screw m 8 p.1.25 x 16
14	0.080.1513.2	1	dipstick A = mm 85
15	2.1539.065.0	2	special oil seal 8.73 x 1.78
16	2.3199.001.2	1	plug 1/2" gas
17	2.1560.054.0	1	gasket 21 x 26
19	0.044.1567.0	2	oil filter element
20	2.1560.014.0	1	washer 18.2 x 24
21	2.3339.353.2/10	1	pipe fitting 12 p.1.5-18 p.1.5
22	0.086.1550.2	6	sprayer nozzle
23	2.1099.108.2	6	special nut m 10 p.1
24	2.1560.006.0	12	gasket 10.2 x 16
25	0.065.1160.3/20	6	valve
26	2.1470.004.2	34	lock washer 8
27	2.0112.237.2	2	screw m 8 p.1.25x140
28	2.0112.215.2	25	screw m 8 p.1.25 x 40
29	0.007.0792.0/10	1	oil sump
30	2.0112.229.2	3	screw m 8 p.1.25 x 100
30	2.0112.235.2	3	screw m 8 p.1.25 x 130
30	2.0112.241.2	1	screw m 8 p.1.25 x 160
36	2.1539.040.0	1	special oil seal 21.82 x 3.53
37	0.065.1538.0	1	flange
38	2.1011.105.2	1	nut m 8 p.1.25

524 - 6

Section: ENGINE

LUBRICATION =>1170

Fig.	P/n	QTY	Name
------	-----	-----	------

Notes:

[H 6115 ELITE]

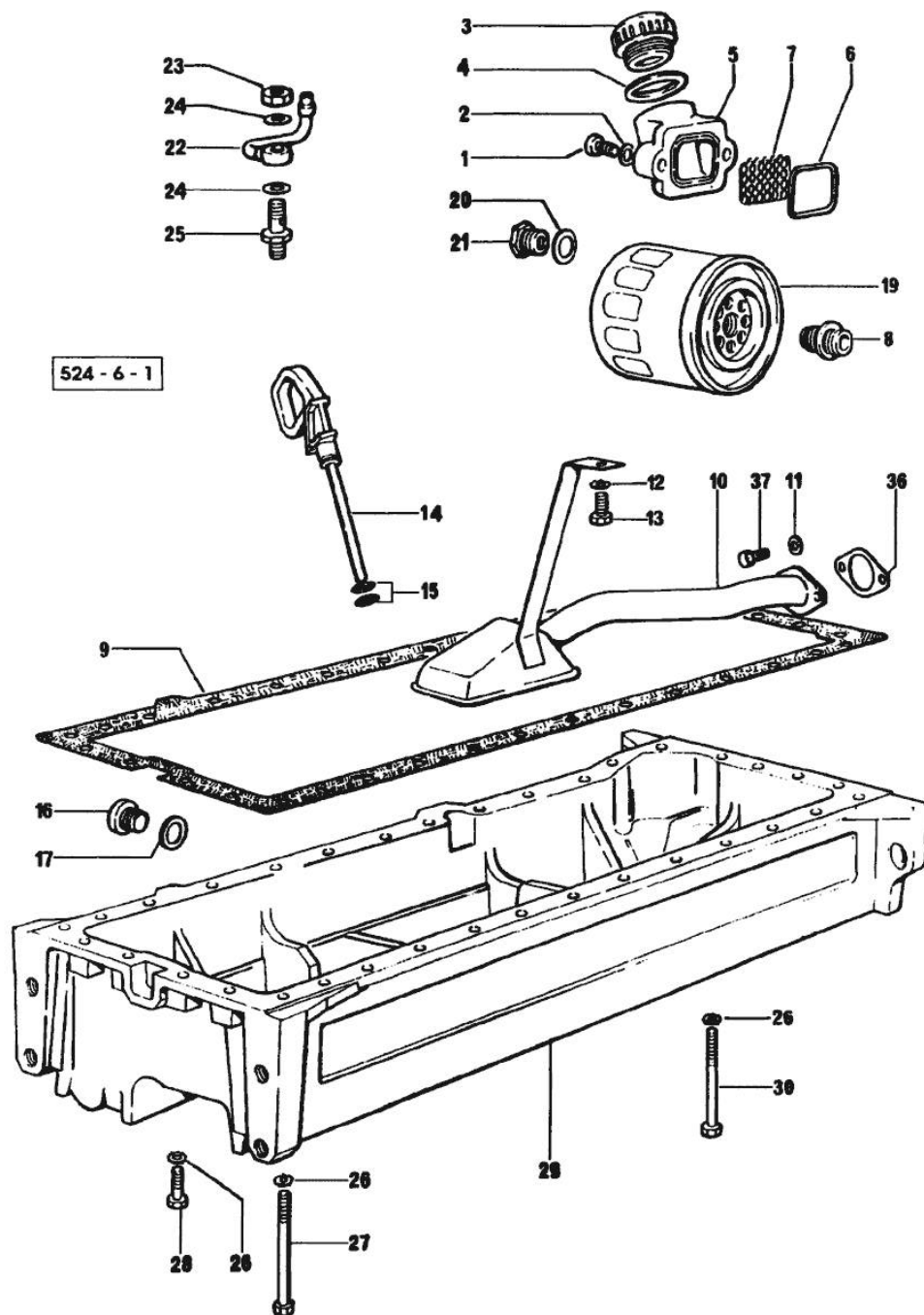

1	2.0312.205.2	2	screw
2	2.1480.014.1	2	washer 8
3	0.041.1135.4	1	plug 1" gas
4	2.1569.072.0	1	gasket 32 x 39.5 x 2
5	0.065.1565.0/10	1	pipe union
6	2.1539.042.0	1	special oil seal 47.35x1.78
7	0.065.1567.0/10	1	filter
8	2.3339.307.0	2	pipe fitting m 22 p.1.5-3/4"
9	0.007.0849.0	1	gasket
10	0.007.0995.3	1	tube
11	2.1470.004.2	2	lock washer 8
12	2.1470.004.2	1	lock washer 8
13	2.0112.205.2	1	screw m 8 p.1.25 x 16
14	0.080.1513.2	1	dipstick A = mm 85
15	2.1539.065.0	2	special oil seal 8.73 x 1.78
16	2.3199.001.2	1	plug 1/2" gas
17	2.1560.054.0	1	gasket 21 x 26
19	0.044.1567.0	2	oil filter element
20	2.1560.014.0	1	washer 18.2 x 24
21	2.3339.353.2/20	1	pipe fitting 12 p.1.5-18 p.1.5
22	0.086.1550.2	6	sprayer nozzle
23	2.1099.108.2	6	special nut m 10 p.1
24	2.1560.006.0	12	gasket 10.2 x 16
25	0.065.1160.3/20	6	valve
26	2.1470.004.2	34	lock washer 8
27	2.0112.237.2	2	screw m 8 p.1.25x140
27	2.0112.241.2	2	screw m 8 p.1.25 x 160
28	2.0112.215.2	25	screw m 8 p.1.25 x 40
29	0.007.0991.0	1	oil sump 1289<=
29	0.007.1311.0	1	oil sump =>1290
30	2.0112.229.2	3	screw m 8 p.1.25 x 100
30	2.0112.235.2	2	screw m 8 p.1.25 x 130
30	2.0112.241.2	2	screw m 8 p.1.25 x 160
36	0.007.0997.0	1	gasket
37	2.0112.207.2	2	screw m 8 p 1.25 x 20

Section: ENGINE
LUBRICATION

Fig.	P/n	QTY	Name
------	-----	-----	------

Notes:
 [H 6115 ELITE]

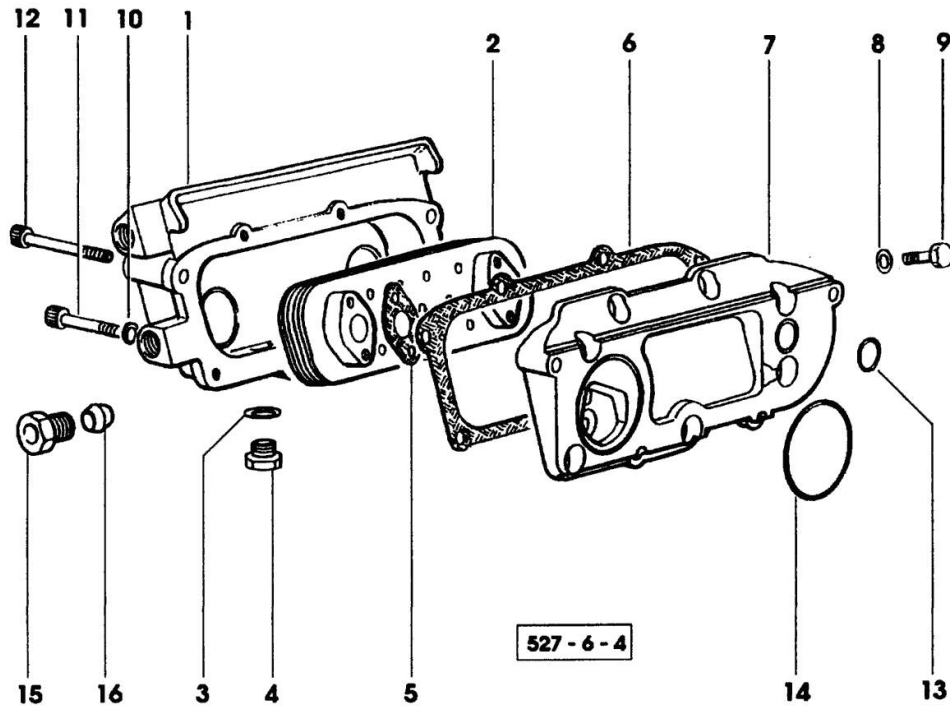

1	0.007.0703.0/10	1	box
2	0.007.1239.3	1	radiator
3	2.1560.014.0	1	washer 18.2 x 24
4	2.3120.101.0	1	plug m 18 p.1.5
5	0.078.1557.0	2	gasket
6	0.078.1556.0	1	gasket
7	0.078.1555.0/10	1	plate
8	2.1310.004.2	8	flat washer 8.4x17
9	2.0112.205.2	8	screw m 8 p.1.25 x 16
10	2.1480.014.1	4	washer 8
11	2.0312.220.1	2	screw m 8 p.1.25x70
12	2.0312.222.2	2	screw m 8 p.1.25 x 80
13	2.1539.048.0	1	special oil seal 20.35x1.78
14	2.1539.050.0	1	special oil seal 69.57x1.78
15	2.3249.023.1	2	pipe fitting m 24 p.2
16	2.3350.008.1	2	nosepiece 18

Section: ENGINE
LUBRICATION

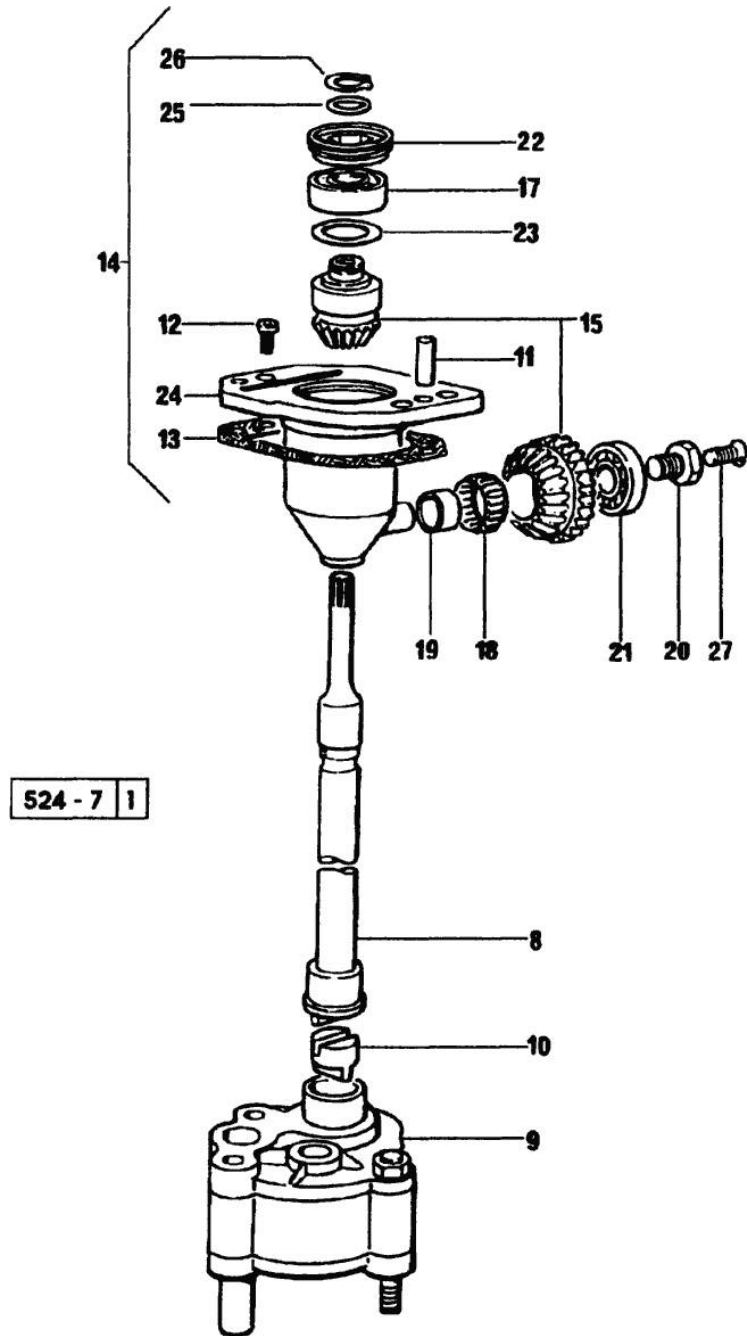

524 - 7 1

Fig.	P/n	QTY	Name
------	-----	-----	------

Notes:
[H 6115 ELITE]

8	0.065.1569.0/20	1	shaft
9	0.007.0271.4/20	1	oil pump
10	0.065.1562.0/10	1	joint
11	2.1652.711.0	2	cylindrical plug 8x25
12	2.0169.005.2	2	screw m 6 p.1 x 12
13	0.065.1560.0/20	2	gasket
14	0.075.1551.4/20	1	support
15	0.065.1558.6/10	1	bevel drive
17	2.2020.001.0	1	ball bearing 15 x 32 x 8.00
18	2.2725.016.0	1	roller cage 15 x 21 x 12
19	2.2680.020.0	1	ring 12 x 15 x 12
20	2.0399.128.2/10	1	screw m 8 p.1 x 8
21	2.2030.002.0	1	ball bearing 12 x 28 x 8
22	2.1219.025.2/10	1	ring nut m 36 p.1.5
23	2.1589.148.0	1	shoulder ring 28.2 x 31.8 x 0.5
23	2.1589.150.0	1	shoulder ring 28.2 x 31.8 x 0.1
23	2.1589.151.0	1	shoulder ring 28.2 x 31.8 x 0.15
24	0.075.1551.3/30	1	support
25	2.1589.146.0	1	shoulder ring 15.2 x 19 x 0.15
25	2.1589.147.0	1	shoulder ring 15.2 x 19 x 0.10
25	2.1589.153.0	1	shoulder ring 15.2 x 19 x 1.00
26	2.1410.057.1	1	circlip 15
27	2.0342.007.2	1	screw m 4 p.0.7x25

Section: ENGINE
LUBRICATION

Fig.	P/n	QTY	Name
------	-----	-----	------

Notes:

=>1170 X H 6115 ELITE [H 6115 ELITE]

8	2.0112.322.2	3	screw m 10 p.1.5x65
9	2.1310.006.2	3	flat washer 10.5x21
10	0.007.0972.0	1	shim
11	0.007.0973.0	1	shim
12	0.007.0867.0	1	bush
13	0.007.0983.4	1	oil pump ☞ 0.007.0983.4
14	0.007.1371.0	1	piston
15	0.007.1373.0	1	spring
16	0.007.1372.0	1	cup
17	0.007.1438.0	1	gear
18	0.007.1437.0	1	washer
19	0.007.1436.0	1	circlip
20	0.000.0000.1	1	cannot be supplied

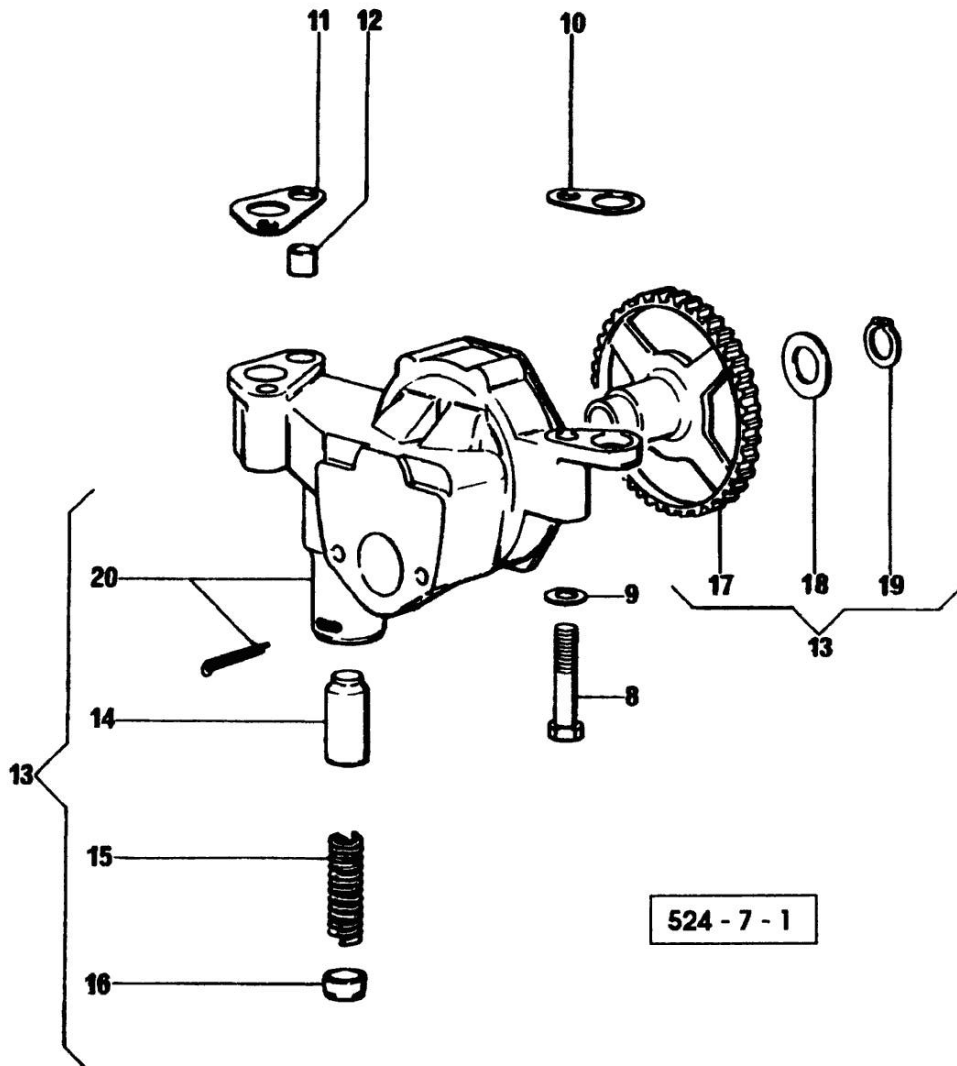

Section: ENGINE
LUBRICATION

Fig.	P/n	QTY	Name
------	-----	-----	------

Notes:
[H 6115 ELITE]

1	0.075.1557.4	1	sediment bowl ☞ 01.00.15
2	2.1560.008.0	1	gasket 12.2 x 18
3	2.1539.072.0	2	special oil seal 23.52 x 1.78
4	0.075.1553.0	1	bush
5	2.0312.221.2	2	screw m 8 p.1.25x75
6	2.1480.014.1	2	washer 8
7	2.6859.086.0	2	clamp
8	0.007.0861.0	1	tube
9	0.075.1554.0	1	tube
10	0.075.1151.0	1	bracket
11	2.3350.003.1	1	nosepiece 8
12	2.3339.418.1	1	pipe fitting m 12 p.1
13	0.007.0970.0	1	tube =>1170 X H 6115 ELITE =>1151 X H 6135 ELITE
13	0.075.1516.0	1	- 1169<= X H 6115 ELITE 1150<= X H 6135 ELITE
14	2.6859.086.0	1	clamp
15	0.075.1453.0	1	tube
16	0.002.8816.0	1	small plate =>1170 X H 6115 ELITE =>1151 X H 6135 ELITE
17	2.0112.007.2	1	screw m 6 p.1 x 20
18	2.1310.002.2	1	flat washer 6.4x12.5
19	2.1011.103.2	1	nut m 6 p.1
20	0.075.1552.2	1	bracket 1169<= X H 6115 ELITE 1150<= X H 6135 ELITE
21	0.075.1552.0	1	bracket 1169<= X H 6115 ELITE 1150<= X H 6135 ELITE
22	2.1011.103.1	1	nut
23	2.1470.002.2	1	lock washer 6

523 - 8 | 1

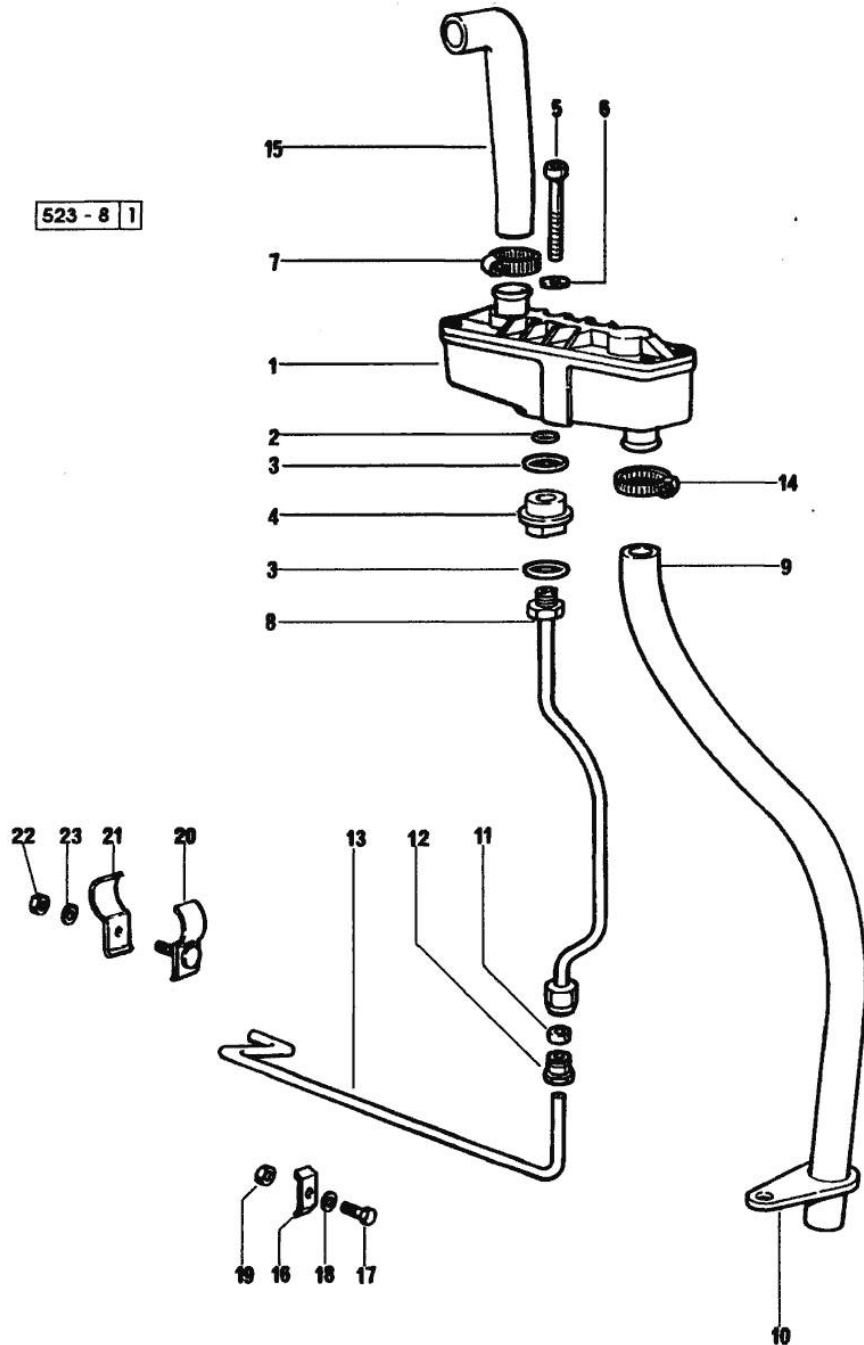



Suggest:

For more complete manuals. Please go to the home page.

<https://www.ebooklibonline.com>

If the above button click is invalid. Please download this document first, and then click the above link to download the complete manual.

Thank you so much for reading

Section: ENGINE

OIL VAPORS SEDIMENT BOWL PARTS

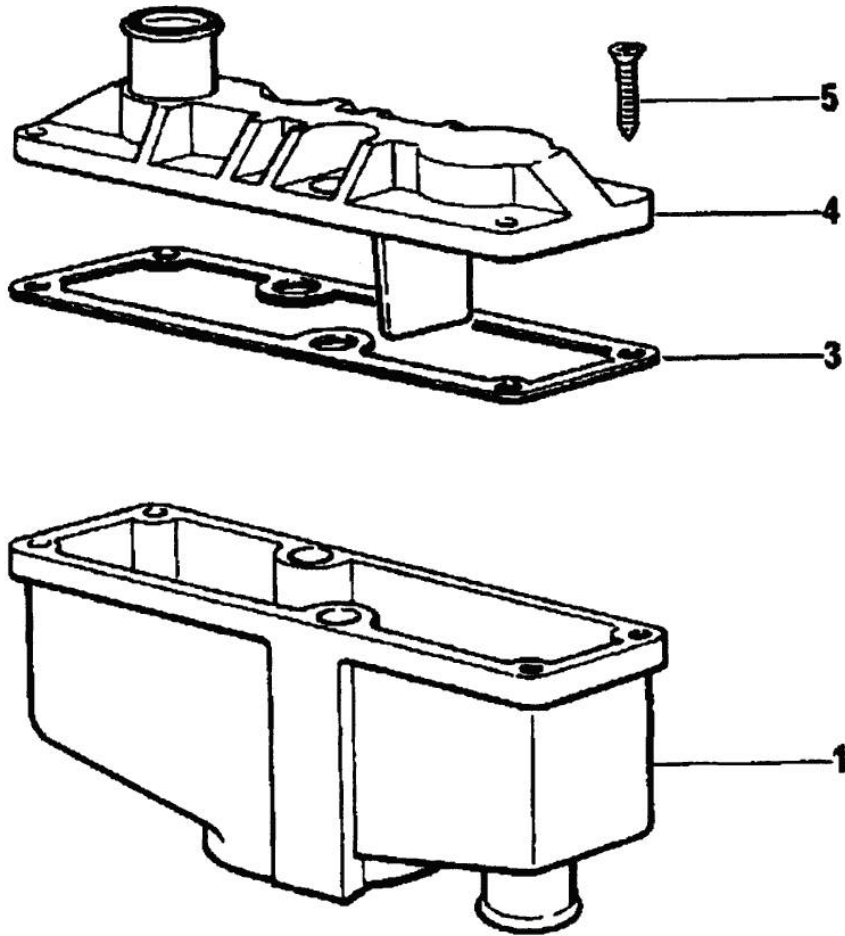

Fig.	P/n	QTY	Name
------	-----	-----	------

Notes:
[H 6115 ELITE]

1	0.075.1558.3	1	old part number
3	0.075.1559.0	1	gasket
4	0.075.1557.3	1	old part number
5	2.0351.203.2	4	screw 3.5x9.5

075.1557.4 *

Section: ENGINE
FUEL SUPPLY SYSTEM

523 - 10

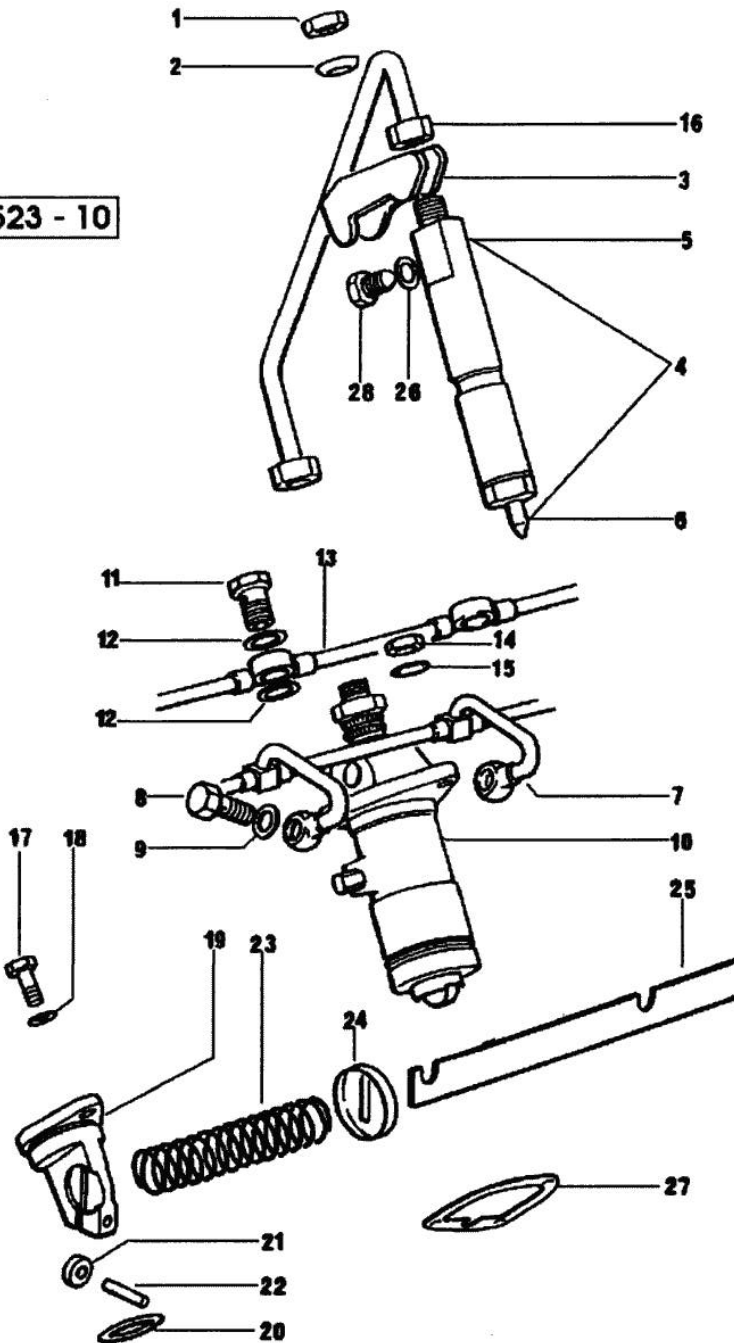

Fig.	P/n	QTY	Name
Notes:			
[H 6115 ELITE]			
1	2.1011.421.2	6	nut m 10 p.1.25
2	2.1599.454.0	6	shoulder ring 10.5x17x7.5
3	0.066.1666.0	6	bracket
4	2.4719.200.0/10	6	injector assembly BOSCH
5	2.4719.190.0	1	nozzle holder BOSCH ☞ 2.4719.190.0 ☞ 01.00.22
6	2.4729.100.0	1	nozzle BOSCH
7	0.007.1789.3	1	tube
8	2.3339.001.0	6	pipe fitting m 10 p.1
9	2.1560.005.0	12	copper gasket 10.2 x 14
10	2.4619.031.0	1	injector pump "A" (...)<= ☞ 2.4619.031.0 ☞ 01.00.20
10	2.4619.031.1	1	injector pump "B" (...)<= ☞ 2.4619.031.1 ☞ 01.00.20
10	2.4619.031.2	1	injector pump "C" (...)<= ☞ 2.4619.031.2 ☞ 01.00.20
10	2.4619.031.3	1	injector pump "D" (...)<= ☞ 2.4619.031.3 ☞ 01.00.20
10	2.4619.050.0	1	injector pump - 517 - BOSCH => (...) ☞ 01.00.21
11	2.3339.118.1	6	pipe union m 12 p.1.5
12	2.1560.008.0	12	gasket 12.2 x 18
13	0.075.1646.3/10	1	tube
14	2.1011.405.2	18	nut m 8 p.1
15	2.1599.458.0/10	18	shoulder ring 8.4x18x2
16	0.065.1650.3	6	tube
17	2.0112.207.2	3	screw m 8 p 1.25 x 20
18	2.1470.004.2	3	lock washer 8
19	0.065.1693.0/10	3	support
20	2.1530.072.0	3	oil seal 26.70x1.78
21	0.065.1660.0	2	roller

<https://www.ebooklibonline.com>

Hello dear friend!

Thank you very much for reading.

Enter the link into your browser.

The full manual is available for immediate download.

<https://www.ebooklibonline.com>