

Section: ENGINE
CRANKCASE

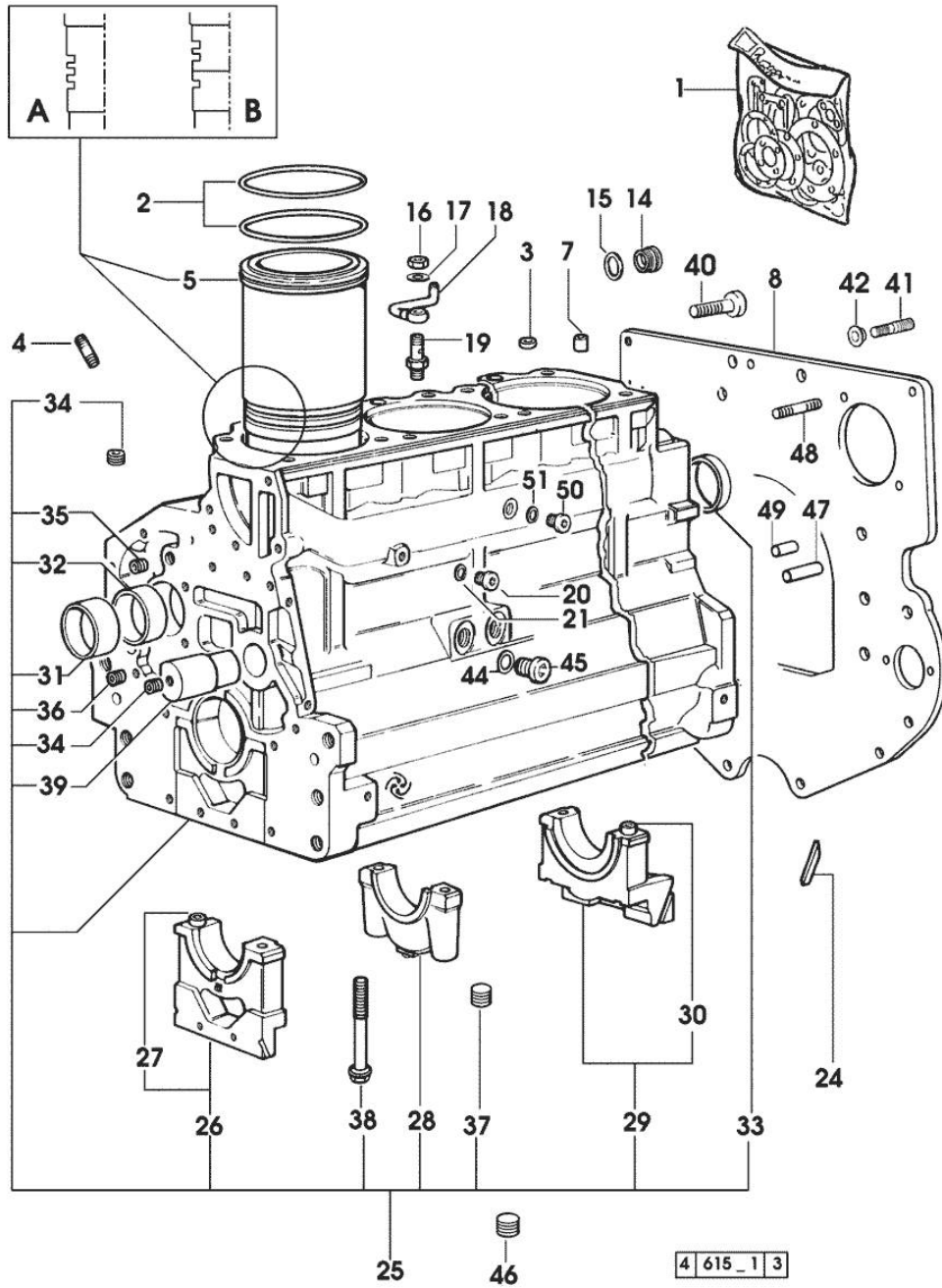

Fig.	P/n	QTY	Name
Notes: [H-478-4 -> 10500]			
1	0.089.0050.6		gasket set - FOR ENGINE MOUNTING
2	2.1519.096.0/20	12	special oil seal 107.67x1.78 25080 <=
2	2.1539.193.0	8	special oil seal 107.62x2.62 => 25081
3	2.1559.188.2	4	bush 11.4 x 14 x16
4	2.0432.003.7	12	stud bolt m 8 p.1.25 / p.1 x 20
5	0.009.7500.0/10	4	engine cylinder (...) <- = A
5	0.011.0183.0/20	4	engine cylinder => 25081
5	0.011.0582.0	4	engine cylinder = B => (...) - 25080 <=
7	2.1549.154.2	4	bush 4.8x5.8x16
8	0.066.1130.0/20	1	flange
14	2.3199.405.2	1	plug m 28 p.1.5
15	2.1539.047.0	1	special oil seal 26.7x1.78
16	2.1099.108.2	4	special nut m 10 p.1
17	2.1560.006.0	8	gasket 10.2 x 16
18	0.086.1550.2	4	sprayer nozzle
19	0.065.1160.3/20	4	valve
20	2.3199.292.0	1	plug 1/4" gas
21	2.1560.010.0	1	gasket 14.2 x 20
24	0.066.1152.0/10	4	gasket
25	0.082.1110.6/20	1	crankcase * 25080 <= - N.4 011.0183.0/10 - N.8 2.1539.193.0
26	0.065.1112.7	1	support
27	2.1699.165.0	1	bush 12.3x15x16
28	0.065.1114.0/10	3	support
29	0.065.1116.3	1	support
30	2.1699.165.0	1	bush 12.3x15x16
31	0.065.1141.0	1	special bushing 59X55X30
32	0.065.1140.0	4	special bushing 59X55X20
33	2.3179.012.0	1	plug 60
34	2.3130.001.1	11	plug 1/8" gas
35	2.3130.002.1	2	plug 1/4" gas
36	2.3130.003.1	5	plug 3/8" gas
37	2.1324.011.0	1	plug

Section: ENGINE
CRANKCASE

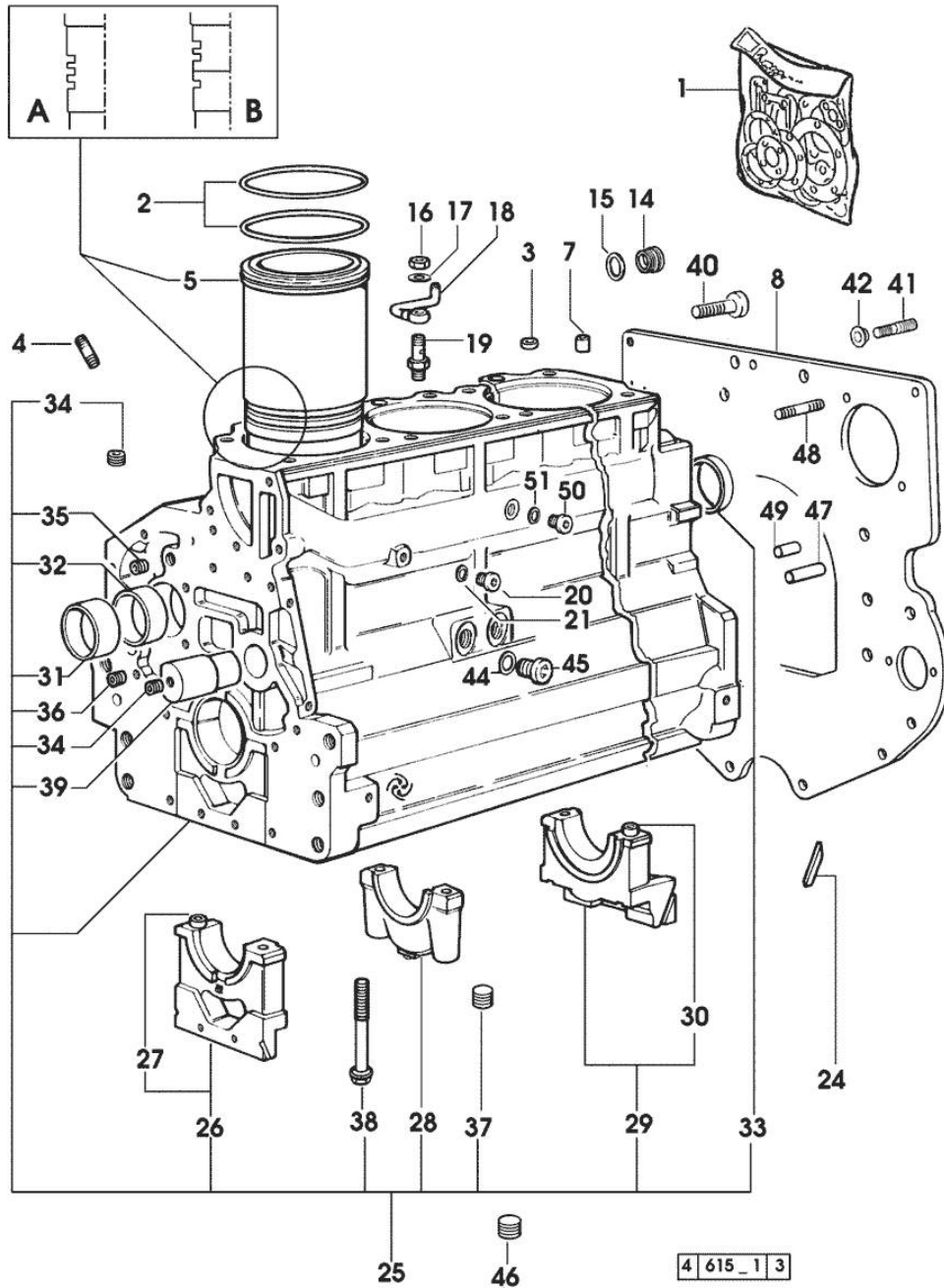

Fig.	P/n	QTY	Name
38	0.065.1117.0	10	screw m 12 x 100
39	0.066.1151.0	1	pin
40	2.0112.511.2	8	screw m 14 p.2 x 30
41	2.0439.250.7	1	stud bolt m 12 / m 10 x 30
42	0.011.9294.0/10	1	bush
44	2.1560.017.0	1	gasket 22.2 x 27
45	2.3120.002.4	1	plug m 22 x 1.5
46	2.3130.003.1	1	plug 3/8" gas
47	2.1651.917.0	1	cylindrical plug 12x40
48	2.0432.255.7	2	stud bolt m 12 p.1.75-1.25x25
49	2.1651.912.0	2	cylindrical plug 12x28
50	2.3120.101.0	1	plug m 18 p.1.5 => 25081
51	2.1560.014.0	1	washer 18.2 x 24

Section: ENGINE

TIMING CASE

Fig.	P/n	QTY	Name
------	-----	-----	------

Notes:

[H-478-4 -> 10500]

1	0.007.1262.3/50	1	guard
2	0.007.1271.0/10	1	small column m 8 p.1.25 / L = mm 60
3	0.007.1272.0/10	2	small column m 8 p.1.25 / L = mm 50
5	2.1310.004.2	3	flat washer 8.4x17
7	2.0112.205.2	3	screw m 8 p.1.25 x 16

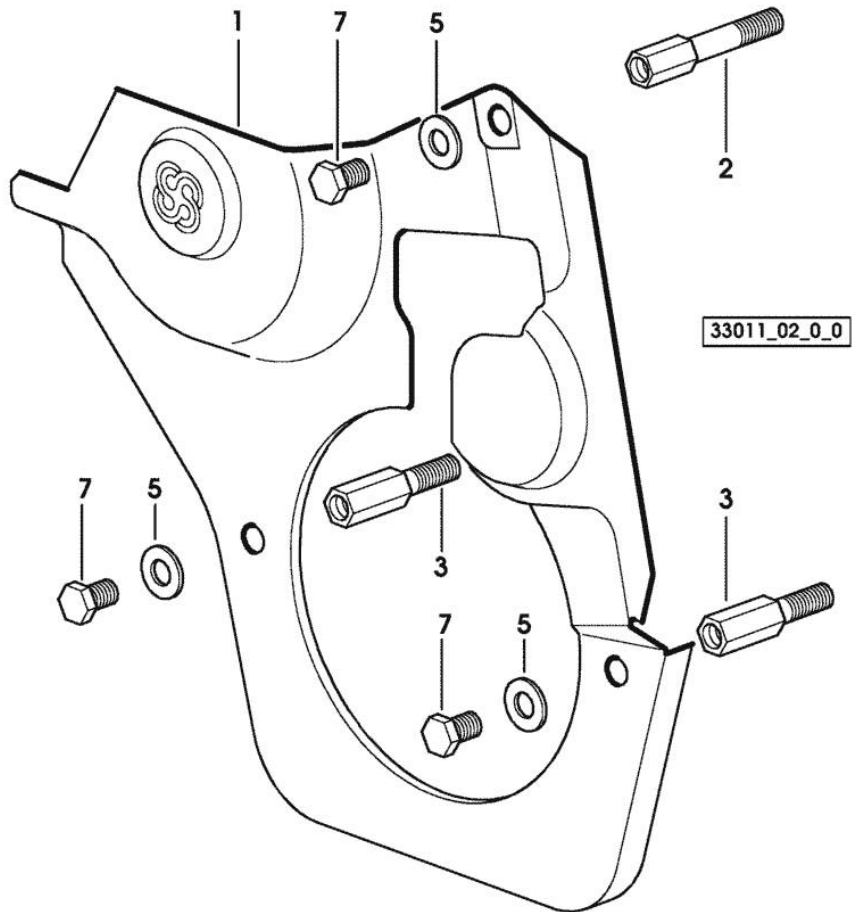

<https://www.ebooklibonline.com>

Hello dear friend!

Thank you very much for reading.

Enter the link into your browser.

The full manual is available for immediate download.

<https://www.ebooklibonline.com>

Section: ENGINE

TIMING CASE

Fig.	P/n	QTY	Name
------	-----	-----	------

Notes:

[H-478-4 -> 10500]

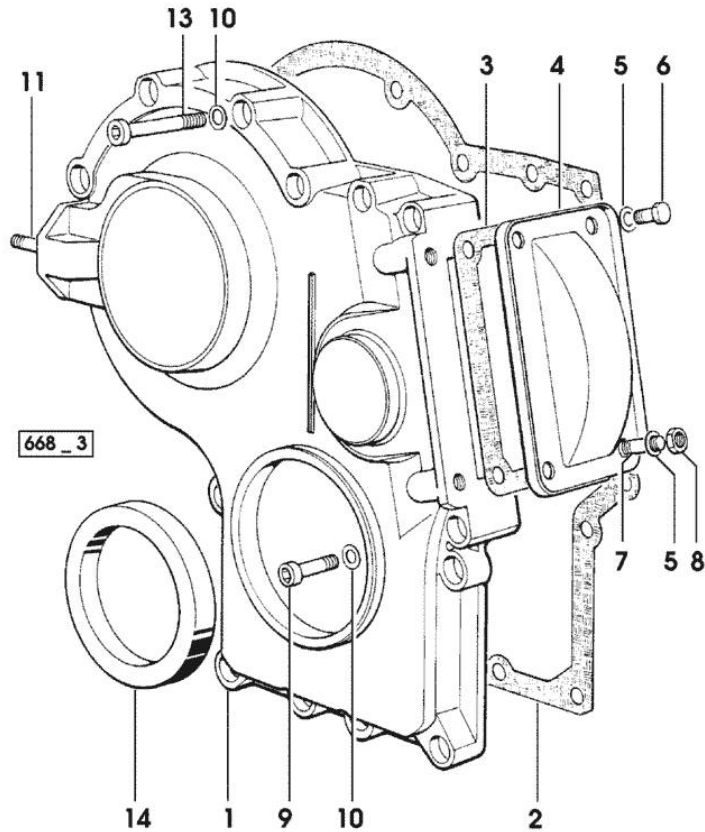

1	0.065.1132.0/60	1	guard
2	0.065.1150.0/30	1	gasket
3	0.065.1152.0	1	gasket
4	0.065.1151.0	1	cover
5	2.1470.004.2	4	lock washer 8
6	2.0112.205.2	2	screw m 8 p.1.25 x 16
7	2.0432.003.7	2	stud bolt m 8 p.1.25 / p.1 x 20
8	2.1011.405.2	2	nut m 8 p.1
9	2.0312.208.2	8	screw m 8 p.1.25 x 25
10	2.1480.014.1	15	washer 8
11	2.0432.003.7	2	stud bolt m 8 p.1.25 / p.1 x 20
13	2.0312.214.1	7	screw m 8 p.1.25 x 40
14	2.1529.141.0	1	special oil seal

Section: ENGINE

CRANKSHAFT

Fig.	P/n	QTY	Name
------	-----	-----	------

Notes:
[H-478-4 -> 10500]

1	0.086.1210.3/30	1	crankshaft
2	0.065.1211.0/10	1	crown wheel
3	2.1630.608.0	1	pin 6x16
4	2.3130.001.1	4	plug 1/8" gas
5	0.078.1220.3/30	4	engine connecting rod
6	2.0399.213.0	8	screw m 12 p.1.25x61.5
7	2.1559.114.0/10	4	special bushing
8	2.0139.022.2	6	screw m 12 p.1.25x55
9	0.007.1702.3/30	1	flywheel
9	0.008.4049.3	1	flywheel mm 373 -> 15575 15574 <-
10	0.065.1242.0	1	crown wheel Z = 123
11	0.086.0060.6/30	4	complete piston
11	0.379.0060.6	4	complete piston - EXPORT U.S.A.
12	0.086.0052.6/10	4	piston ring set
13	2.1411.014.1	8	circlip 35
14	0.078.1236.0	4	piston pin Ø 18 / Ø 35 / L = mm 86
15	2.1720.006.0	2	key 4x6.5
16	0.008.5543.0	1	flange
17	2.1652.915.0	1	cylindrical plug 12x35
18	0.065.1254.0/20	1	gasket
19	0.007.1711.0/10	1	cover
20	2.1529.073.0	1	special oil seal 110x130x13
21	2.0112.207.2	9	screw m 8 p 1.25 x 20
22	2.1475.002.2	9	conical washer 8
23	0.065.1225.0	8	con.rod half bushing STANDARD - A = 28.75 -> 29.00
23	0.065.1225.7		con.rod half bushing - mm 0.25
23	0.065.1225.8		con.rod half bushing - mm 0.50
24	0.065.1215.0	5	main half bushing STANDARD
24	0.065.1215.7		main half bushing - mm 0.25
24	0.065.1215.8		main half bushing - mm 0.50
25	0.065.1216.0	5	main half bushing
25	0.065.1216.7		main half bushing - mm 0.25
25	0.065.1216.8		main half bushing - mm 0.50
26	0.065.1218.0	4	shim STANDARD
26	0.065.1218.7		shim + mm 0.10
26	0.065.1218.8		shim + mm 0.15
27	0.085.1248.0/10	1	hub
28	2.1589.189.0	3	shoulder ring mm 1.00

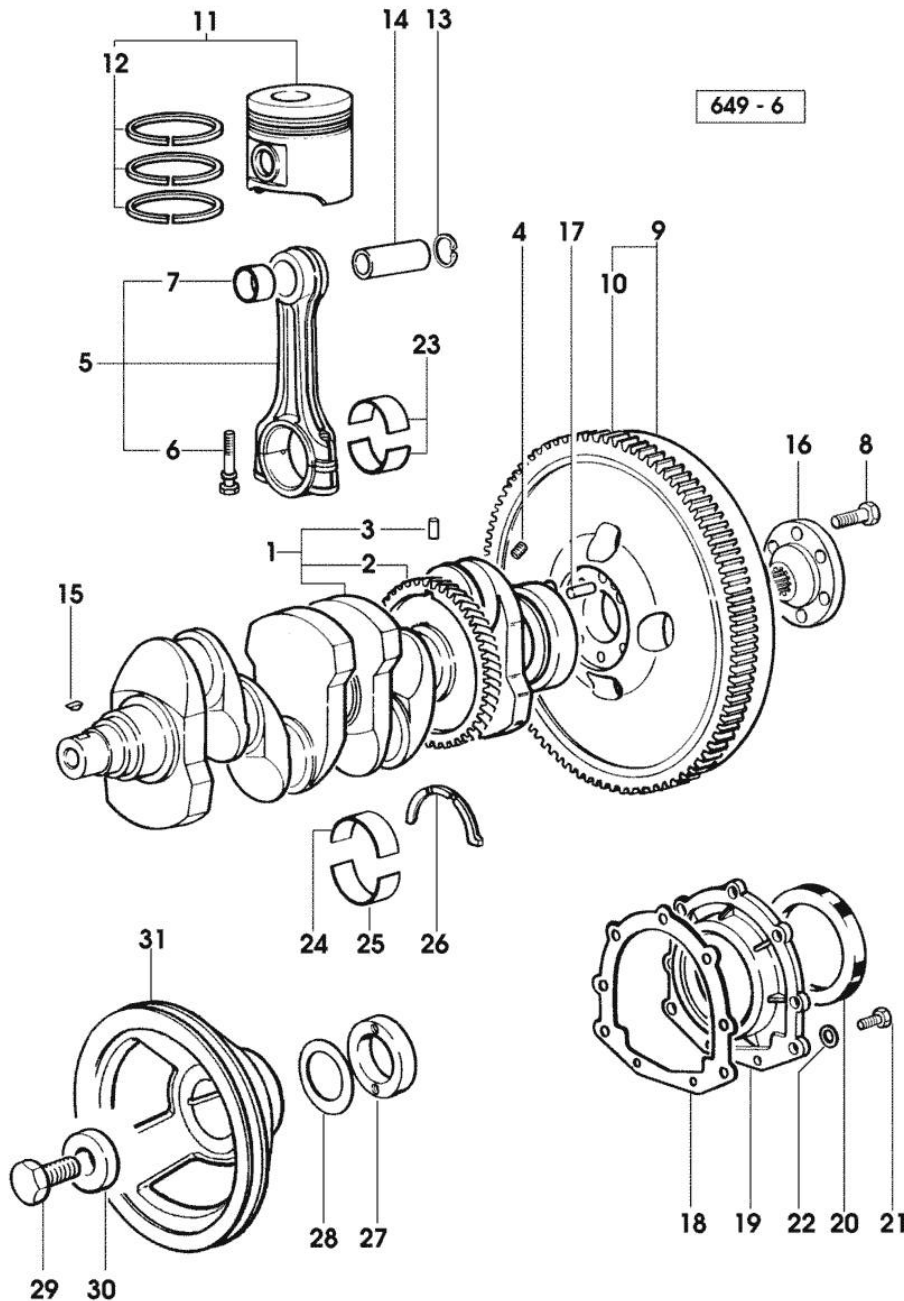

CRANKSHAFT

Fig.	P/n	QTY	Name
29	2.0399.144.7/10	1	screw m 20 p.1.5x51
30	2.1599.524.7	1	washer 21x60x12
31	0.007.1457.0/20	1	pulley

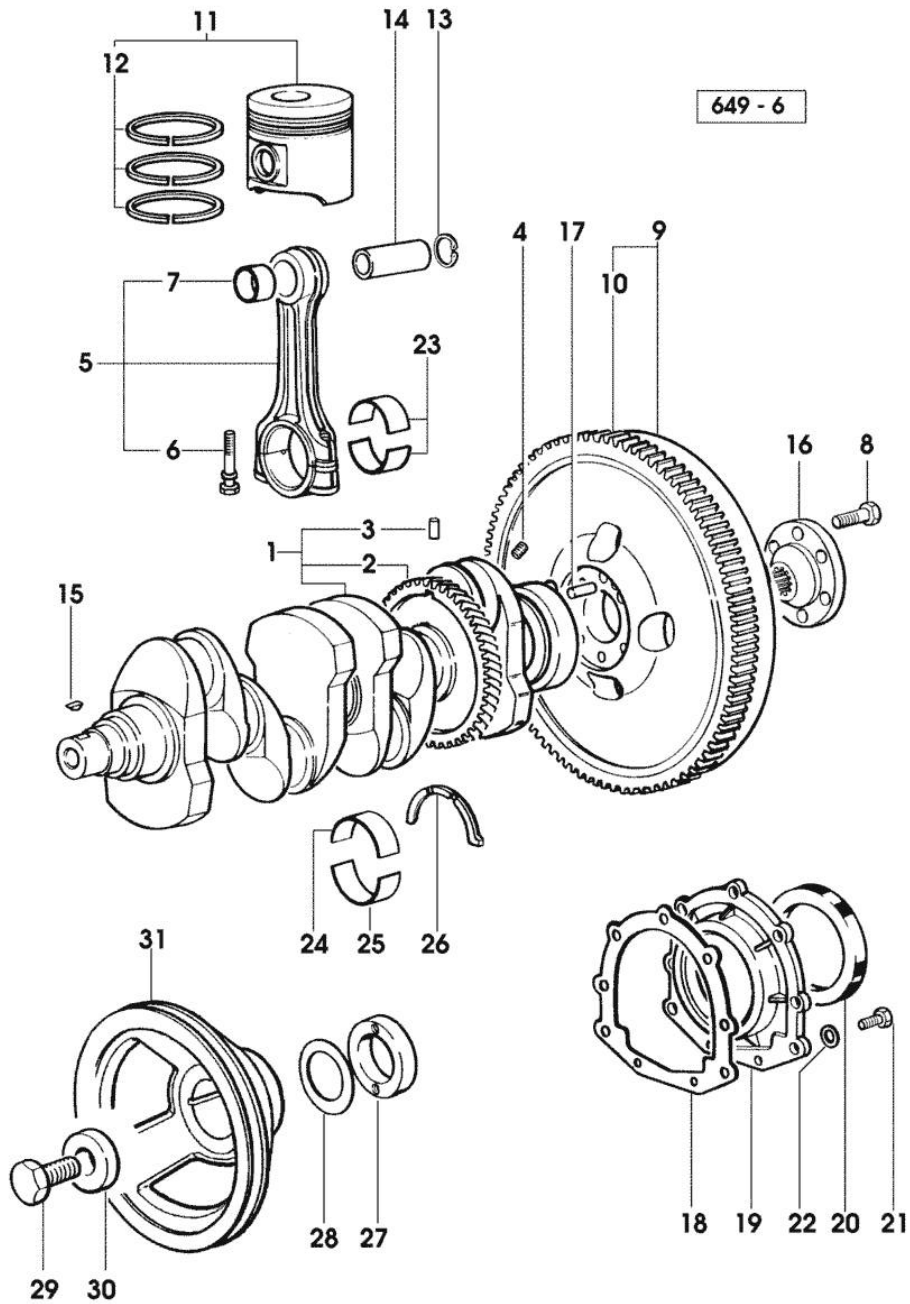

Section: ENGINE
COUNTERWEIGHTS

Fig.	P/n	QTY	Name
------	-----	-----	------

Notes:
 [H-478-4 -> 10500]

1	0.086.1233.3/30	1	mass sx/lh/li
2	2.1559.115.0	2	special bushing 26x30x30
3	2.1652.302.0	1	roll pin 4x6
4	0.000.0000.1		cannot be supplied
5	0.065.1233.3/30	1	mass dx/rh/re
6	2.1410.018.1	1	circlip 45
7	2.1652.302.0	1	roll pin 4x6
8	2.1559.115.0	2	special bushing 26x30x30
9	0.000.0000.1		cannot be supplied
10	2.1589.185.0	4	shoulder ring 26.1x34x1
11	2.1631.717.0	2	roll pin 8 x 40
12	0.086.1231.0/10	1	box
13	2.3130.001.1	4	plug 1/8" gas
14	2.0139.028.2	4	screw m 12
15	2.1579.629.0		spacer 12.5x26x0.1
16	2.1589.049.0		shoulder ring 12.5x26x0.3
17	2.1579.626.0	2	spacer 13.2x16x11
18	2.1589.140.0		shoulder ring mm 0.1
19	2.1589.139.0		shoulder ring mm 0.3
20	2.1699.191.0	1	bush 7x10x16
21	0.065.1234.0/10	2	shaft
22	2.3130.001.1	1	plug 1/8" gas
23	2.1579.628.0		spacer 16.5x26x0.1
23	2.1589.048.0		shoulder ring 16.5x26x0.3

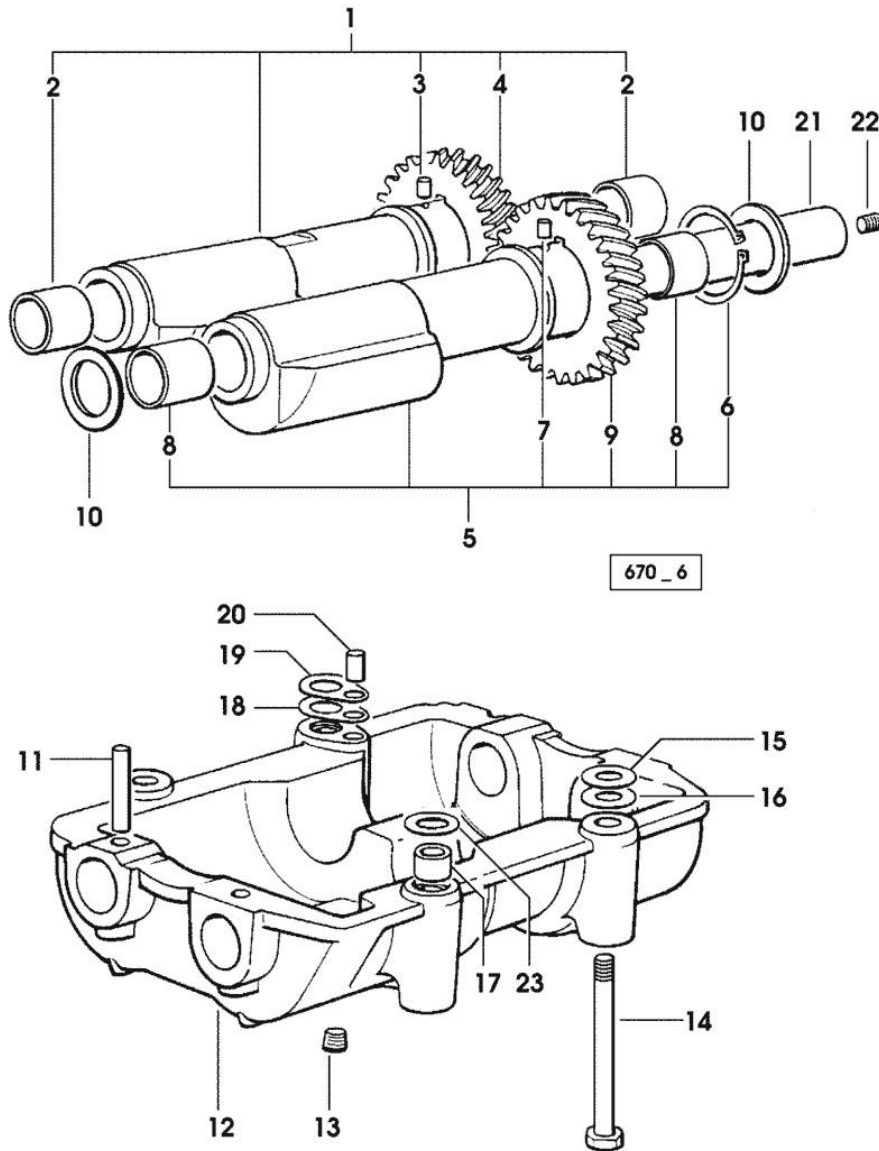

Section: ENGINE

CAMSHAFT

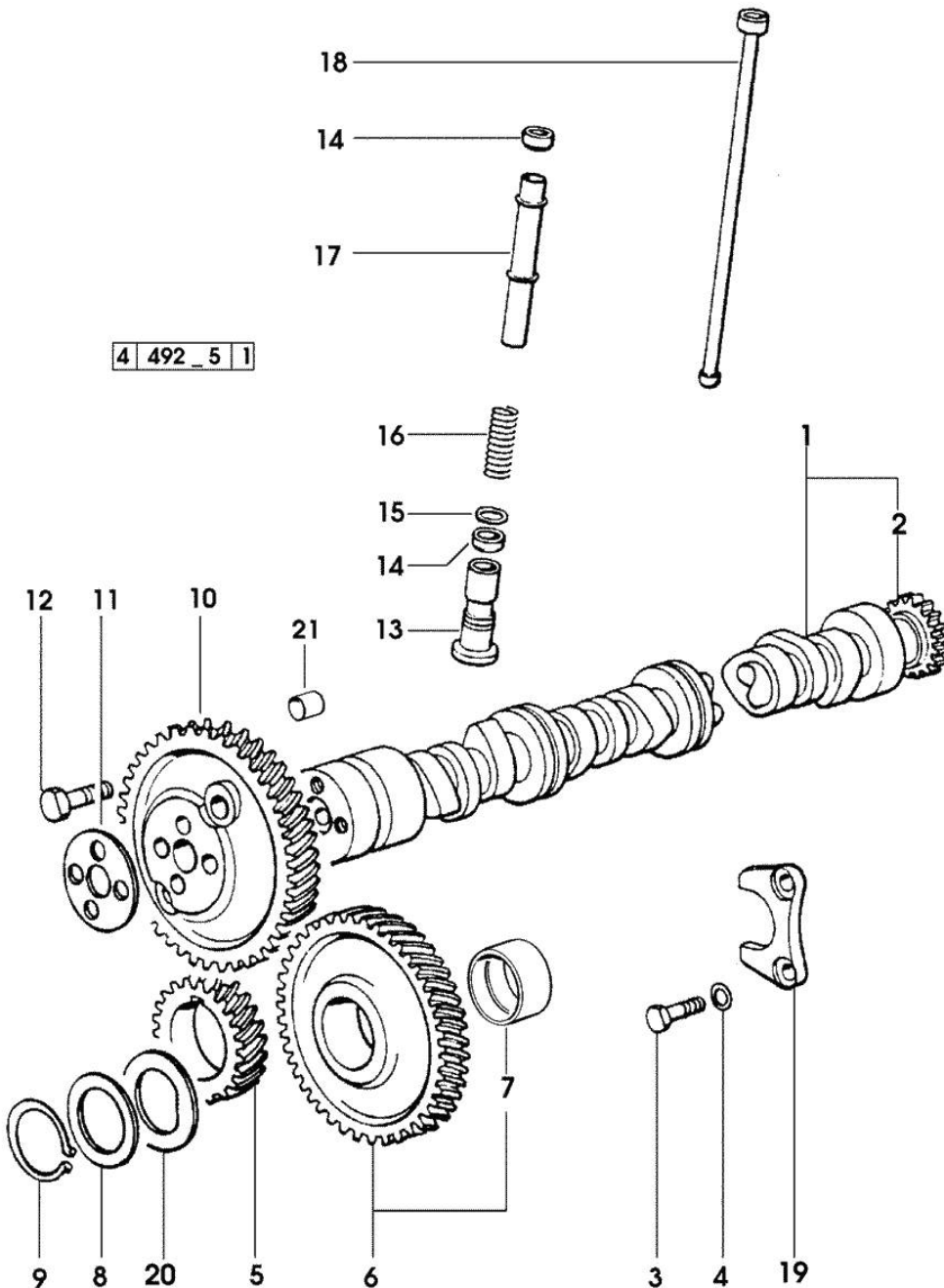

Fig.	P/n	QTY	Name
------	-----	-----	------

Notes:
[H-478-4 -> 10500]

1	0.007.1712.3/10	1	camshaft - EXPORT U.S.A.
1	0.066.1310.3/40	1	camshaft
2	0.065.1324.0/10	1	gear Z = 32
3	2.0312.206.2	2	screw m 8 p 1.25 x 20
4	2.1480.014.1	2	washer 8
5	0.065.1323.0/30	1	gear Z = 29
6	0.007.1177.3/10		gear z = 57 - WITH RED IDENTIFICATION STAMP
6	0.007.1178.3/10		gear z = 57 - WITH YELLOW IDENTIFICATION STAMP
6	0.007.1179.3/10		gear z = 57 - WITH GREEN IDENTIFICATION STAMP
7	2.1559.185.0/10	1	bushing
8	0.065.1352.0	1	shim
9	2.1410.016.1	1	circlip 40
10	0.065.1354.0/20	1	gear z=58
11	0.065.1350.0	1	small disc
12	2.0132.207.2	4	screw m 10 p.1 x 25
13	0.065.1330.0	8	tappets
14	2.1569.114.0/10	16	gasket 14x18.5x8
15	2.1599.437.0	8	shoulder ring
16	2.4019.300.1/10	8	spring 18.5x52x2
17	0.065.1332.0	8	sleeve
18	0.065.1331.2	8	rod
19	0.065.1353.0	1	small plate
20	0.065.1351.0	2	shoulder ring
21	2.1559.398.0	1	bushing 10.5x13x12

Section: ENGINE
CYLINDER HEAD

Fig.	P/n	QTY	Name
------	-----	-----	------

Notes:
[H-478-4 -> 10500]

1	2.0432.011.7	4	stud bolt m 8 p.1.25 / p.1 x 40
2	2.0432.161.7	4	stud bolt m 10 p.1.5 / p.1.25 x 40
4	0.010.6016.0	4	inlet valve mm 43.63 / Ø mm 9
5	0.066.1421.0	4	exhaust valve
6	0.074.1423.0	16	conical valve cotter
7	0.066.1425.0	8	cup
8	2.4019.287.0	8	spring
9	0.066.1443.0/10	16	screw
10	0.066.1432.3	8	rocker arm
11	2.1559.021.0/40	8	bushing 15x19x22
12	2.1599.432.0	2	shoulder ring
13	2.1410.055.1	2	circlip 19
14	2.0432.163.7	8	stud bolt m 10 p.1.5 / p.1.25 x 45
15	2.1011.421.2	8	nut m 10 p.1.25
16	0.021.1434.0	8	screw
17	2.1011.405.2	8	nut m 8 p.1
18	0.007.1139.0/10	4	small cap
19	0.065.1450.0/30	1	tappet gasket
20	2.0399.130.2/10	4	screw m 8x36x44
21	2.1569.170.0/10	4	gasket 8.2 x 14
22	0.078.1451.0/40		head gasket -A-
22	0.078.1452.0/30		head gasket -B-
22	0.078.1453.0/40		head gasket -C-
24	2.0432.005.7	4	stud bolt m 8 p.1.5 / p.1 x 25
25	0.012.2693.3/10	4	engine head
26	0.007.1779.0/10	8	valve guide
27	0.066.1427.0	4	valve seat
28	0.078.1426.0	4	valve seat
29	0.010.6041.0	4	bush
30	2.3170.012.1	8	expansion plug 30
31	0.066.1431.0	4	pin
32	0.066.1430.0/10	4	support
33	2.1530.051.0	4	oil seal 20.22x3.53
34	2.1519.117.0	8	special oil seal

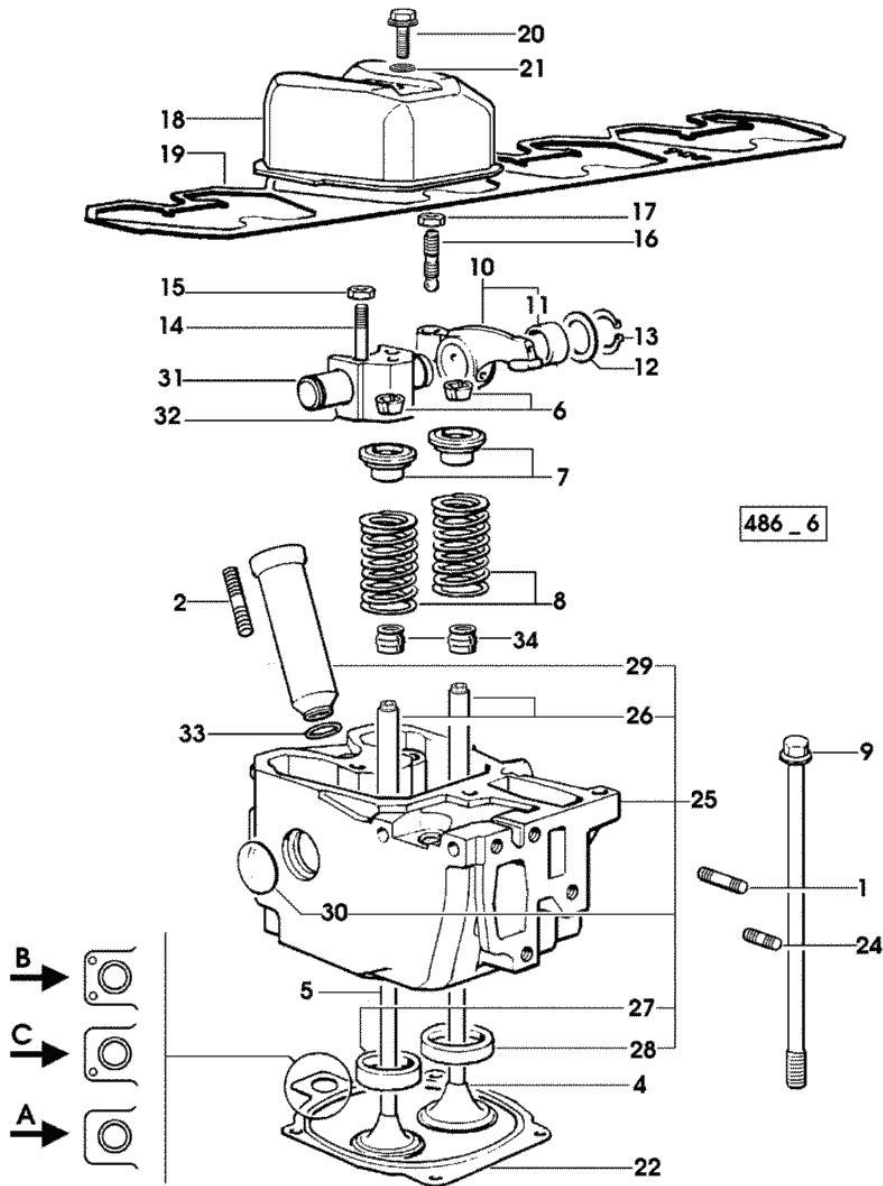



Suggest:

For more complete manuals. Please go to the home page.

<https://www.ebooklibonline.com>

If the above button click is invalid. Please download this document first, and then click the above link to download the complete manual.

Thank you so much for reading

Section: ENGINE
LUBRICATION

Fig.	P/n	QTY	Name
------	-----	-----	------

Notes:
[H-478-4 -> 10500]

1	0.007.1277.0/40	1	oil sump
2	0.065.1550.0/10	1	gasket
3	2.3199.001.2	2	plug 1/2" gas
4	2.0112.239.2	2	screw m 8 p.1.25 x 150
5	2.0112.226.2	4	screw m 8 p.1.25 x 85
6	2.0112.215.2	17	screw m 8 p.1.25 x 40
7	2.1470.004.2	26	lock washer 8
8	0.065.1531.3/20	1	tube
9	2.0112.209.2	1	screw m 8 p 1.25 x 25
10	2.1011.105.2	1	nut m 8 p.1.25
11	2.1470.004.2	2	lock washer 8
12	0.065.1538.0	1	flange
13	2.1539.040.0	1	special oil seal 21.82 x 3.53
14	2.1560.014.0	1	washer 18.2 x 24
15	2.3339.353.2/20	1	pipe fitting 12 p.1.5-18 p.1.5
18	0.086.1513.2/30	1	dipstick
19	2.1539.065.0	2	special oil seal 8.73 x 1.78
23	0.044.1567.0	1	oil filter element
24	2.3339.307.0	1	pipe fitting m 22 p.1.5-3/4"
26	2.1560.054.0	2	gasket 21 x 26
29	2.1579.766.2	1	spacer 8.5x16x10
30	2.0112.235.2	3	screw m 8 p.1.25 x 130

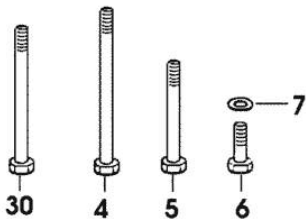
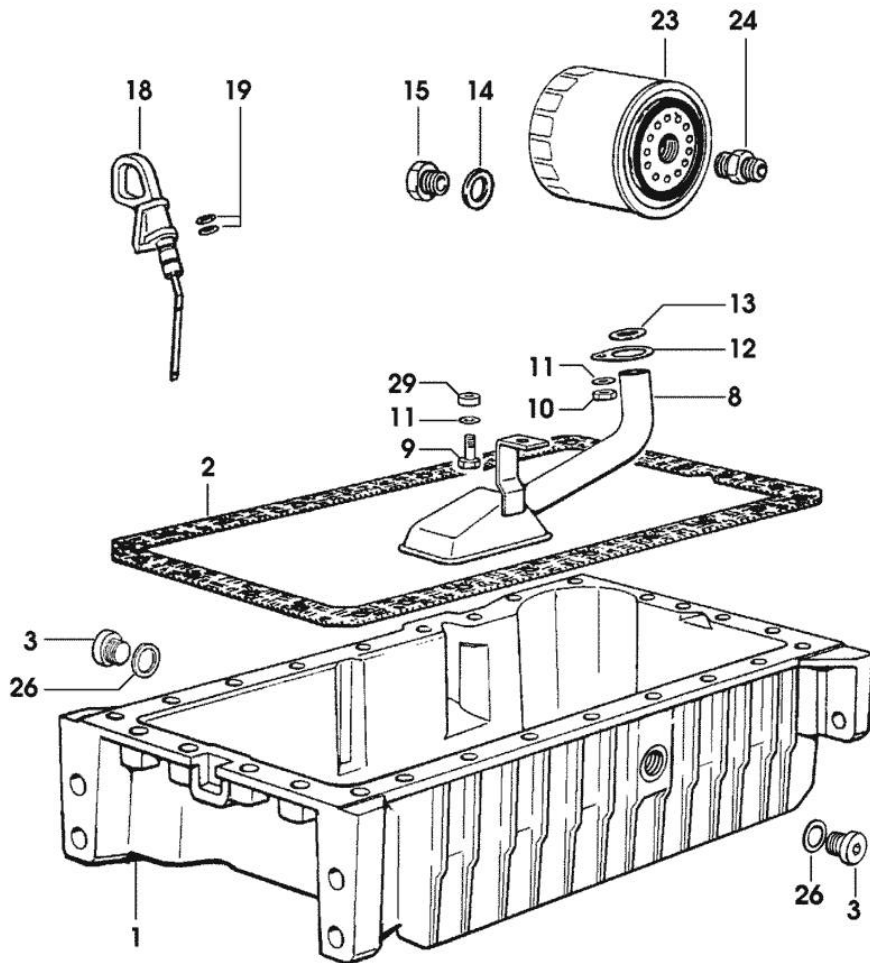

4 668_8 2

Section: ENGINE
LUBRICATION

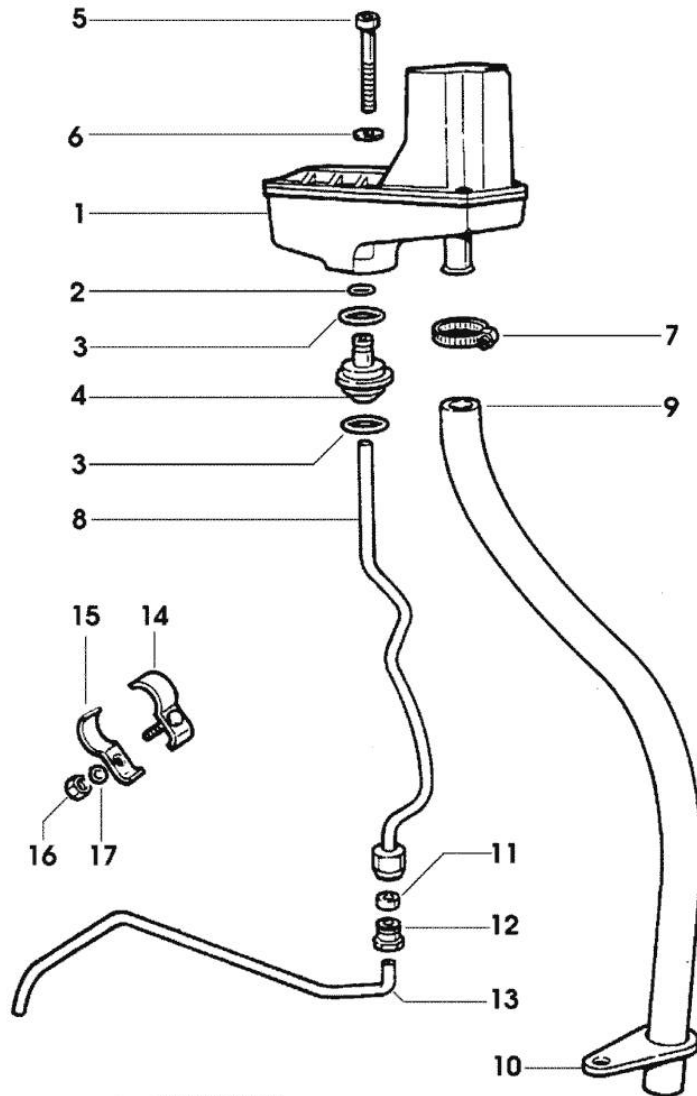

642 - 10

Fig.	P/n	QTY	Name
Notes:			
[H-478-4 -> 10500]			
1	0.066.1552.4/10	1	sediment bowl ☞ 01.00.32
2	2.1539.074.0	1	special oil seal 7.66 x 1.78
3	2.1539.072.0	2	special oil seal 23.52 x 1.78
4	0.066.1558.0	1	bush
5	2.0312.221.2	2	screw m 8 p.1.25x75
6	2.1480.014.1	2	washer 8
7	2.6859.073.2	1	clamp
8	0.066.1557.2	1	tube
9	0.066.1559.0	1	tube
10	0.075.1151.0	1	bracket
11	2.3350.003.1	1	nosepiece 8
12	2.3339.418.1	1	pipe fitting m 12 p.1
13	0.066.1556.0	1	tube
14	0.075.1552.2	1	bracket
15	0.075.1552.0	1	bracket
16	2.1011.103.2	1	nut m 6 p.1
17	2.1470.002.2	1	lock washer 6

<https://www.ebooklibonline.com>

Hello dear friend!

Thank you very much for reading.

Enter the link into your browser.

The full manual is available for immediate download.

<https://www.ebooklibonline.com>