

Section: ENGINE
CRANKCASE

Fig.	P/n	QTY	Name
------	-----	-----	------

Notes:
[H-478 PRESTIGE]

1	0.089.0050.6	1	gasket set - X H 468 - H 478 - FOR ENGINE MOUNTING
1	0.090.0050.6	1	gasket set - X H 488T - FOR ENGINE MOUNTING
2	2.1519.096.0/20	12	special oil seal 107.67x1.78 25055 <= X H-468 24932 <= X H-478 1936 <= X H-488T
2	2.1539.193.0	8	special oil seal 107.62x2.62 => 25056 X H-468 => 24933 X H-478 => 1937 X H-488T
3	2.1559.188.2	4	bush 11.4 x 14 x16
4	2.0432.003.7	12	stud bolt m 8 p.1.25 / p.1 x 20
5	0.009.7500.0/10	4	engine cylinder = A 17700 <= X H-468 - H-478 1851 <= X H-488T
5	0.011.0183.0/20	4	engine cylinder => 25056 X H-468 => 24933 X H-478 => 1937 X H-488T
5	0.011.0582.0	4	engine cylinder = B => 17701 - 25055 <= X H-468 => 17701 - 24932 <= X H-478 => 1852 - 1936 <= X H-488T
7	2.1549.154.2	4	bush 4.8x5.8x16
8	0.066.1130.0/20	1	flange
14	2.3199.405.2	1	plug m 28 p.1.5
15	2.1539.047.0	1	special oil seal 26.7x1.78
16	2.1099.108.2	4	special nut m 10 p.1
17	2.1560.006.0	8	gasket 10.2 x 16
18	0.086.1550.2	4	sprayer nozzle
19	0.065.1160.3/20	4	valve
20	2.3199.292.0	1	plug 1/4" gas
21	2.1560.010.0	1	gasket 14.2 x 20
24	0.066.1152.0/10	4	gasket
25	0.082.1110.6/20	1	crankcase

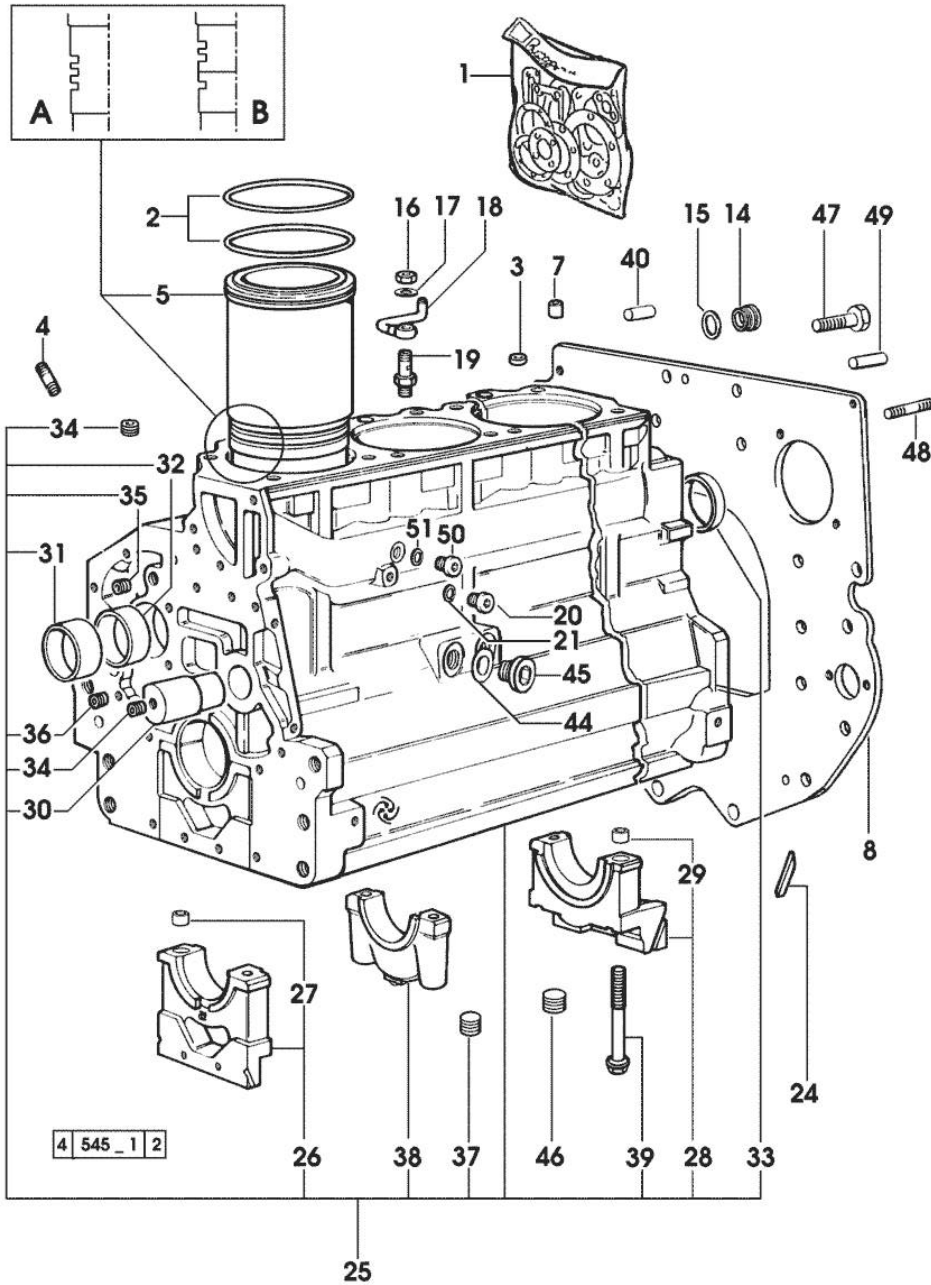

CRANKCASE

Fig.	P/n	QTY	Name
------	-----	-----	------

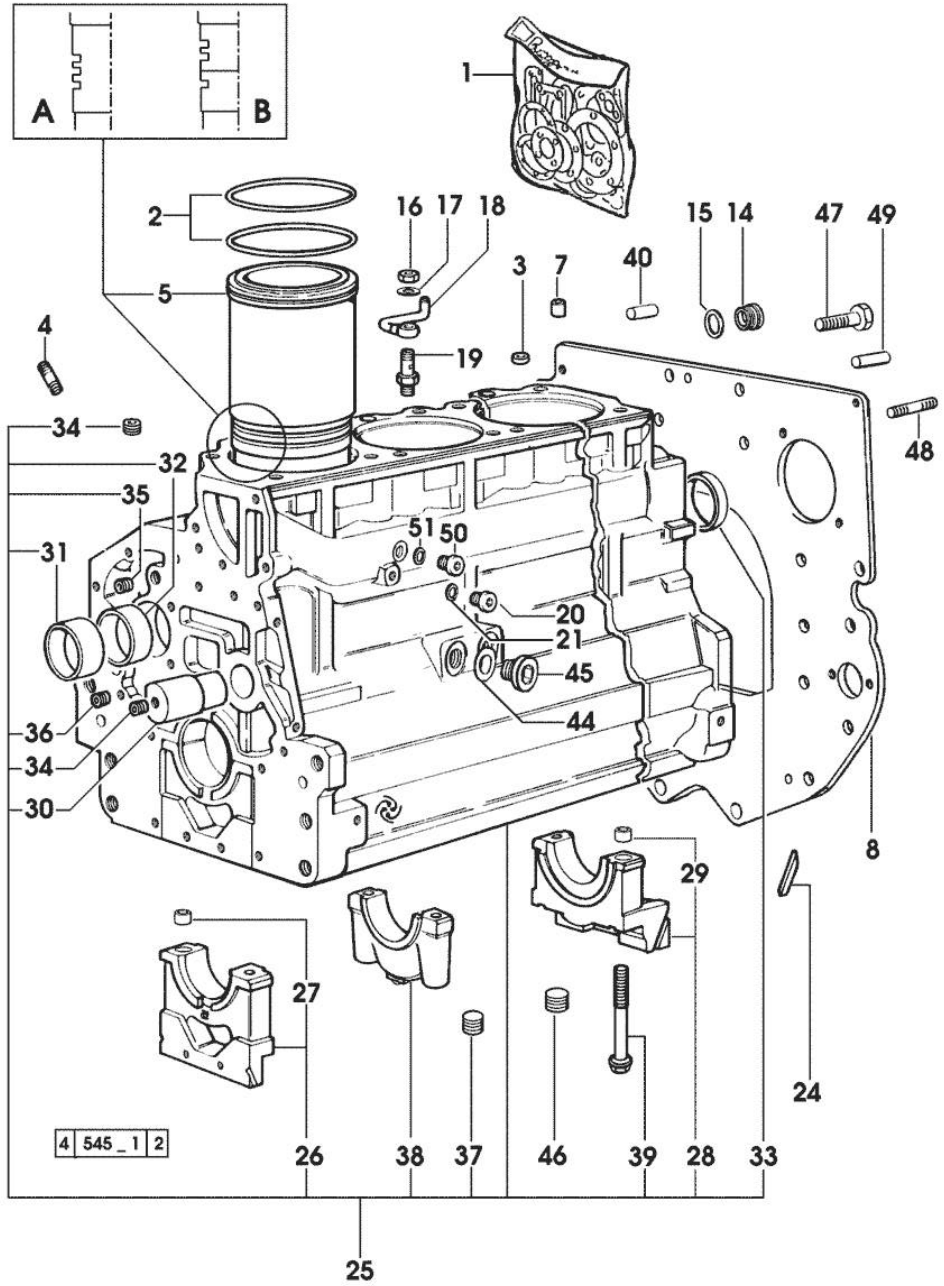

			* 25055 <= X H-468
			* 24932 <= X H-478
			* 1936 <= X H-488T
			- N.4 011.0183.0/10 - N.8 2.1539.193.0
26	0.065.1112.7	1	support
27	2.1699.165.0	1	bush 12.3x15x16
28	0.065.1116.3	1	support
29	2.1699.165.0	1	bush 12.3x15x16
30	0.066.1151.0	1	pin
31	0.065.1141.0	1	special bushing 59X55X30
32	0.065.1140.0	4	special bushing 59X55X20
33	2.3179.012.0	1	plug 60
34	2.3130.001.1	11	plug 1/8" gas
35	2.3130.002.1	2	plug 1/4" gas
36	2.3130.003.1	5	plug 3/8" gas
37	2.1324.011.0	1	plug
38	0.065.1114.0/10	3	support
39	0.065.1117.0	10	screw m 12 x 100
40	2.1651.912.0	2	cylindrical plug 12x28
44	2.1560.017.0	1	gasket 22.2 x 27
			- X H 468 - H 478
45	2.3120.002.4	1	plug m 22 x 1.5
			- X H 468 - H 478
46	2.3130.003.1	2	plug 3/8" gas
47	2.0112.511.2	8	screw m 14 p.2 x 30
48	2.0432.255.7	2	stud bolt m 12 p.1.75-1.25x25
49	2.1651.917.0	1	cylindrical plug 12x40
50	2.3120.101.0	1	plug m 18 p.1.5
			=> (...) - 25055 <= X H-468
			=> (...) - 24932 <= X H-478
			=> (...) - 1936 <= X H-488T
51	2.1560.014.0	1	washer 18.2 x 24

Section: ENGINE
TIMING CASE

Fig.	P/n	QTY	Name
------	-----	-----	------

Notes:
[H-478 PRESTIGE]

1	0.007.1262.3/50	1	guard
2	0.007.1271.0/10	1	small column m 8 p.1.25 / L = mm 60
3	0.007.1272.0/10	2	small column m 8 p.1.25 / L = mm 50
5	2.1310.004.2	3	flat washer 8.4x17
7	2.0112.205.2	3	screw m 8 p.1.25 x 16

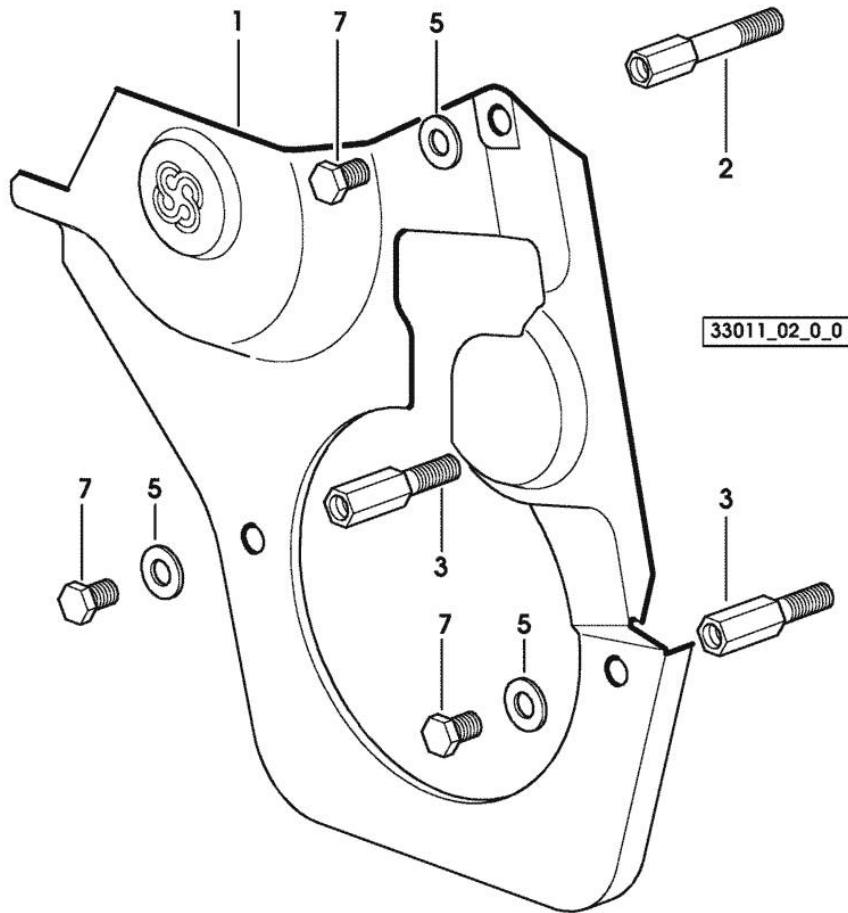

<https://www.ebooklibonline.com>

Hello dear friend!

Thank you very much for reading.

Enter the link into your browser.

The full manual is available for immediate download.

<https://www.ebooklibonline.com>

Section: ENGINE
TIMING CASE

Fig.	P/n	QTY	Name
------	-----	-----	------

Notes:
[H-478 PRESTIGE]

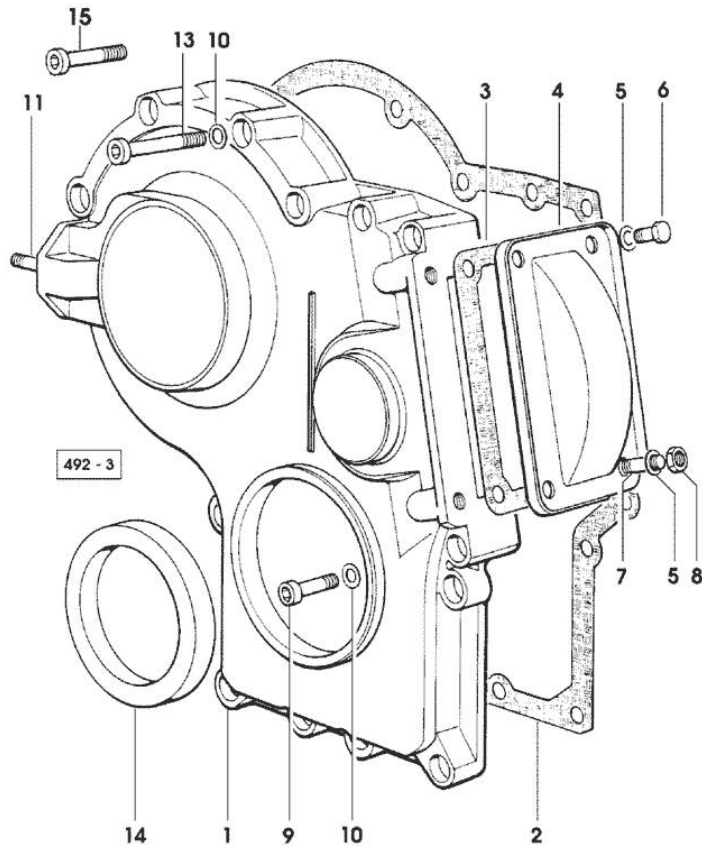

1	0.065.1132.0/60	1	guard
2	0.065.1150.0/30	1	gasket
3	0.065.1152.0	1	gasket
4	0.065.1151.0	1	cover
5	2.1470.004.2	4	lock washer 8
6	2.0112.205.2	2	screw m 8 p.1.25 x 16
7	2.0432.003.7	2	stud bolt m 8 p.1.25 / p.1 x 20
8	2.1011.405.2	2	nut m 8 p.1
9	2.0312.208.2	8	screw m 8 p.1.25 x 25
10	2.1480.014.1	15	washer 8
11	2.0432.003.7	2	stud bolt m 8 p.1.25 / p.1 x 20
13	2.0312.214.2	3	screw m 8 p.1.25 x 40
14	2.1529.141.0	1	special oil seal
15	2.0312.214.2	4	screw m 8 p.1.25 x 40

Section: ENGINE

CRANKSHAFT

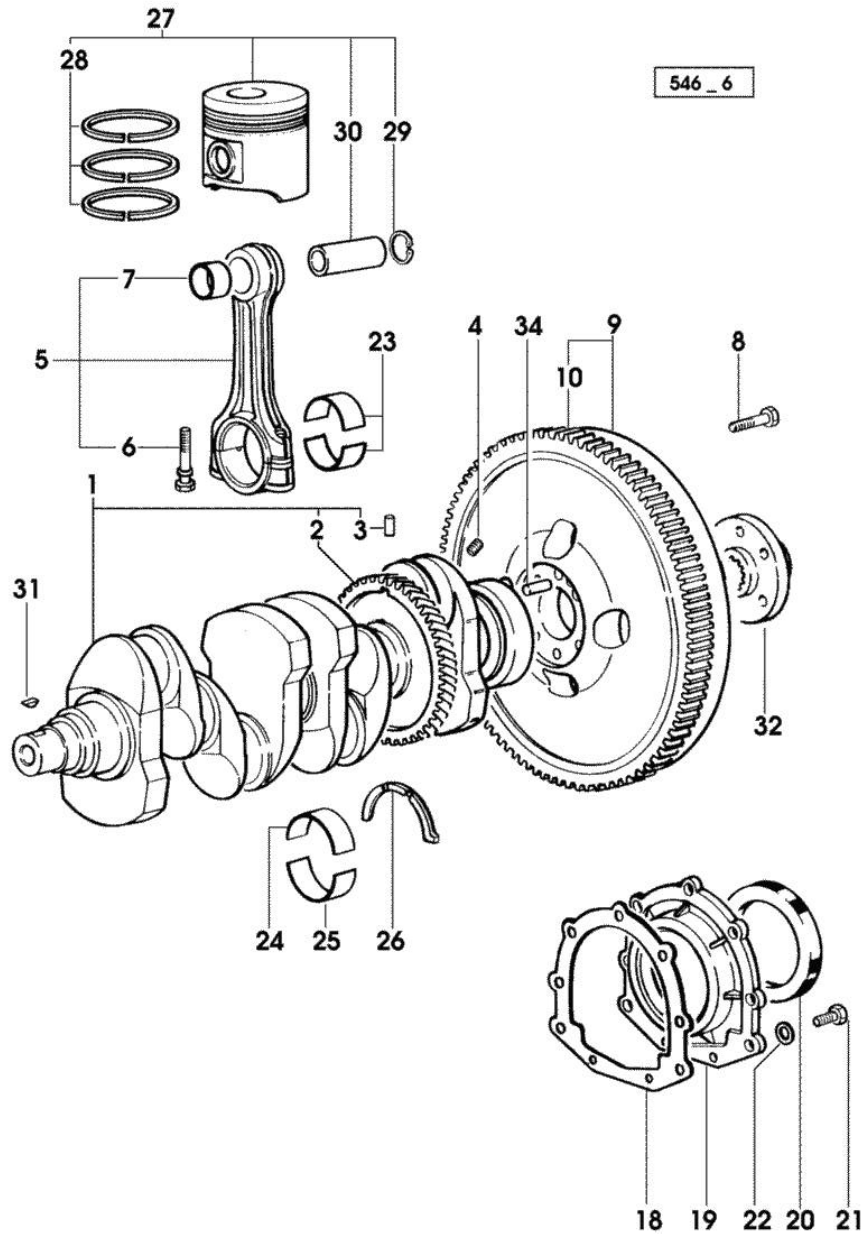

Fig.	P/n	QTY	Name
Notes: [H-478 PRESTIGE]			
1	0.086.1210.3/30	1	crankshaft * 14871 <= X H 478 * 4231 <= X H 488T - N.1 - 007.1711.0/10 - N.4 - 2.3130.001.1
2	0.065.1211.0/10	1	crown wheel
3	2.1630.608.0	1	pin 6x16
4	2.3130.001.1	4	plug 1/8" gas
5	0.078.1220.3/30	4	engine connecting rod
6	2.0399.213.0	8	screw m 12 p.1.25x61.5
7	2.1559.114.0/10	4	special bushing
8	2.0139.022.2	6	screw m 12 p.1.25x55
9	0.007.1702.3/30	1	flywheel -> 20260 X H 478 -> 20695 X H 488T
9	0.008.4049.3	1	flywheel mm 373 -> 20224 - 20259 <- X H 478 -> 20603 - 20694 <- X H 488T
9	0.076.1247.3/20	1	flywheel 20223 <- X H 478 20602 <- X H 488T
10	0.065.1242.0	1	crown wheel Z = 123
18	0.065.1254.0/20	1	gasket
19	0.007.1711.0/10	1	cover => 14872 X H 478 => 4332 X H 488T
19	0.065.1253.0/20	1	cover 14871 <= X H 478 4231 <= X H 488T
20	2.1529.073.0	1	special oil seal 110x130x13
21	2.0112.207.2	9	screw m 8 p 1.25 x 20
22	2.1475.002.2	9	conical washer 8
23	0.065.1225.0	8	con.rod half bushing STANDARD - A = 28.75 -> 29.00
23	0.065.1225.7		con.rod half bushing - mm 0.25
23	0.065.1225.8		con.rod half bushing - mm 0.50
24	0.065.1215.0	5	main half bushing STANDARD
24	0.065.1215.7		main half bushing - mm 0.25
24	0.065.1215.8		main half bushing - mm 0.50
25	0.065.1216.0	5	main half bushing
25	0.065.1216.7		main half bushing - mm 0.25
25	0.065.1216.8		main half bushing - mm 0.50
26	0.065.1218.0	4	shim STANDARD

CRANKSHAFT

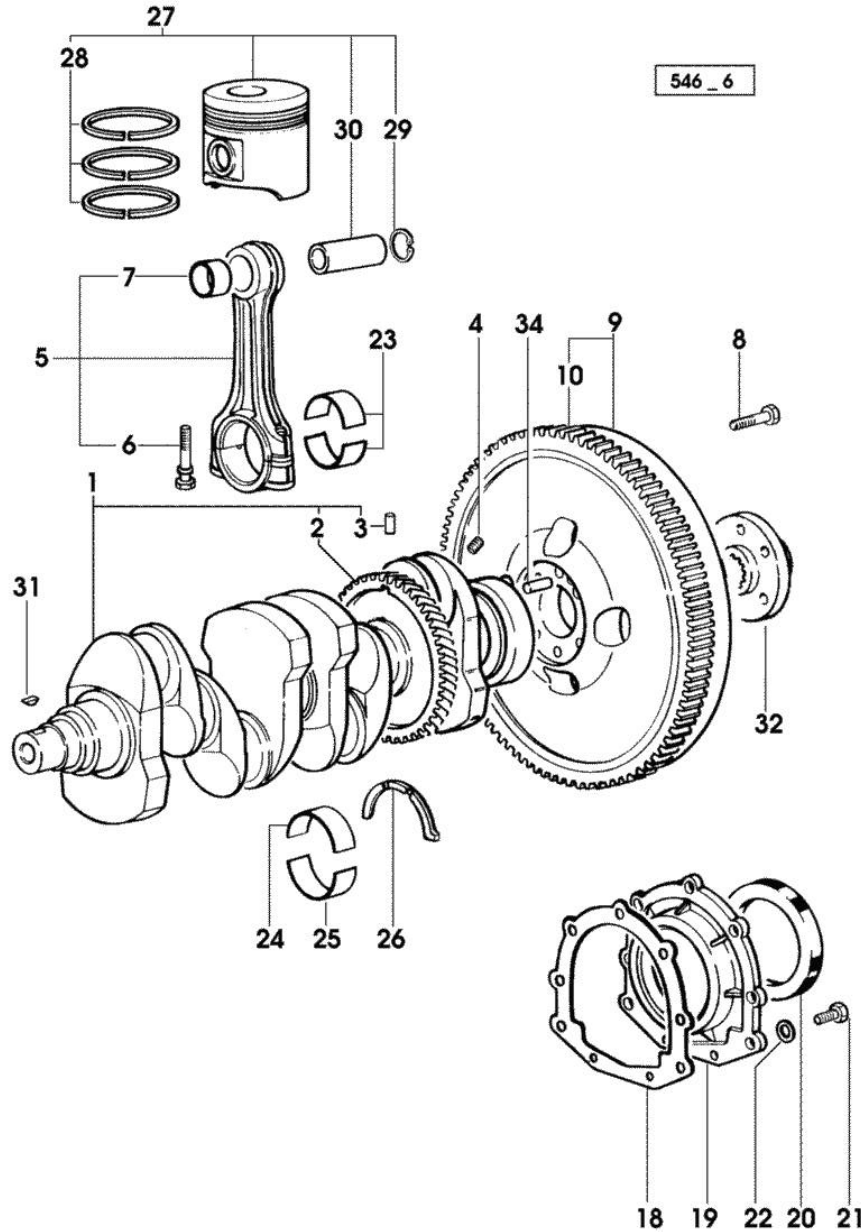

Fig.	P/n	QTY	Name
26	0.065.1218.7		shim + mm 0.10
26	0.065.1218.8		shim + mm 0.15
27	0.086.0060.6/30	4	complete piston - X H 478
27	0.087.0060.6/30	4	complete piston - X H 488T
27	0.379.0060.6	4	complete piston - X H 478 - EXPORT U.S.A.
27	0.382.0060.6	4	complete piston - X H 488T - EXPORT U.S.A.
28	0.081.0090.6/10	4	piston ring set - X H 488T
28	0.086.0052.6/10	4	piston ring set - X H 478
29	2.1411.014.1	8	circlip 35
30	0.078.1236.0	4	piston pin Ø 18 / Ø 35 / L = mm 86
31	2.1720.006.0	3	key 4x6.5
32	0.008.5543.0	1	flange -> 20224 X H 478 -> 20602 X H 488T
32	0.255.2525.0/10	1	flange 20602 <- X H 488T 20223 <- X H 478
34	2.1652.915.0	1	cylindrical plug 12x35

ENGINE SHAFT - PULLEYS

Fig.	P/n	QTY	Name
------	-----	-----	------

Notes:
[H-478 PRESTIGE]

1	0.089.1251.0/10	1	pulley 1320 <= X H 358 8089 <= X H 468 (...) <= X H 478 - H 488T
1	0.089.1252.0/10	1	pulley 1320 <= X H 358 8089 <= X H 468 (...) <= X H 478 - H 488T - FOR TRACTORS WITH AIR CONDITIONING
2	0.085.1254.0	1	ring
3	0.065.1256.0	1	ring 45x52
6	0.007.1457.0/20	1	pulley
7	0.007.1458.0/30	1	pulley - FOR TRACTORS WITH AIR CONDITIONING
8	2.0399.144.7/10	1	screw m 20 p.1.5x51 * (...) <- - N.1 - 2.1599.524.7
9	0.085.1248.0/10	1	hub
10	2.1720.006.0	1	key 4x6.5
11	2.1599.524.7	1	washer 21x60x12 * (...) <= - N.1 - 2.0399.144.7
12	0.082.1244.0/10	1	pulley => 1321 X H 358 => 8090 X H 468 => (...) X H 478 - H 488T
13	0.011.3515.0/10	1	hub Z = 48
14	0.065.1256.0	2	ring 45x52
15	2.1579.865.0	4	spacer 45.2x51.8x10
16	2.0439.195.7	1	stud bolt m 20 p.1.5x80
17	2.1019.094.7	1	nut m 20 p.1.5
18	2.1599.524.7	1	washer 21x60x12
19	0.082.1250.0/10	1	pulley => 1321 X H 358 => 8090 X H 468 => (...) X H 478 - H 488T - FOR TRACTORS WITH AIR CONDITIONING
20	0.011.3515.0/10	1	hub Z = 48
21	0.065.1256.0	2	ring 45x52
22	2.1579.865.0	1	spacer 45.2x51.8x10
23	2.0439.195.7	1	stud bolt m 20 p.1.5x80

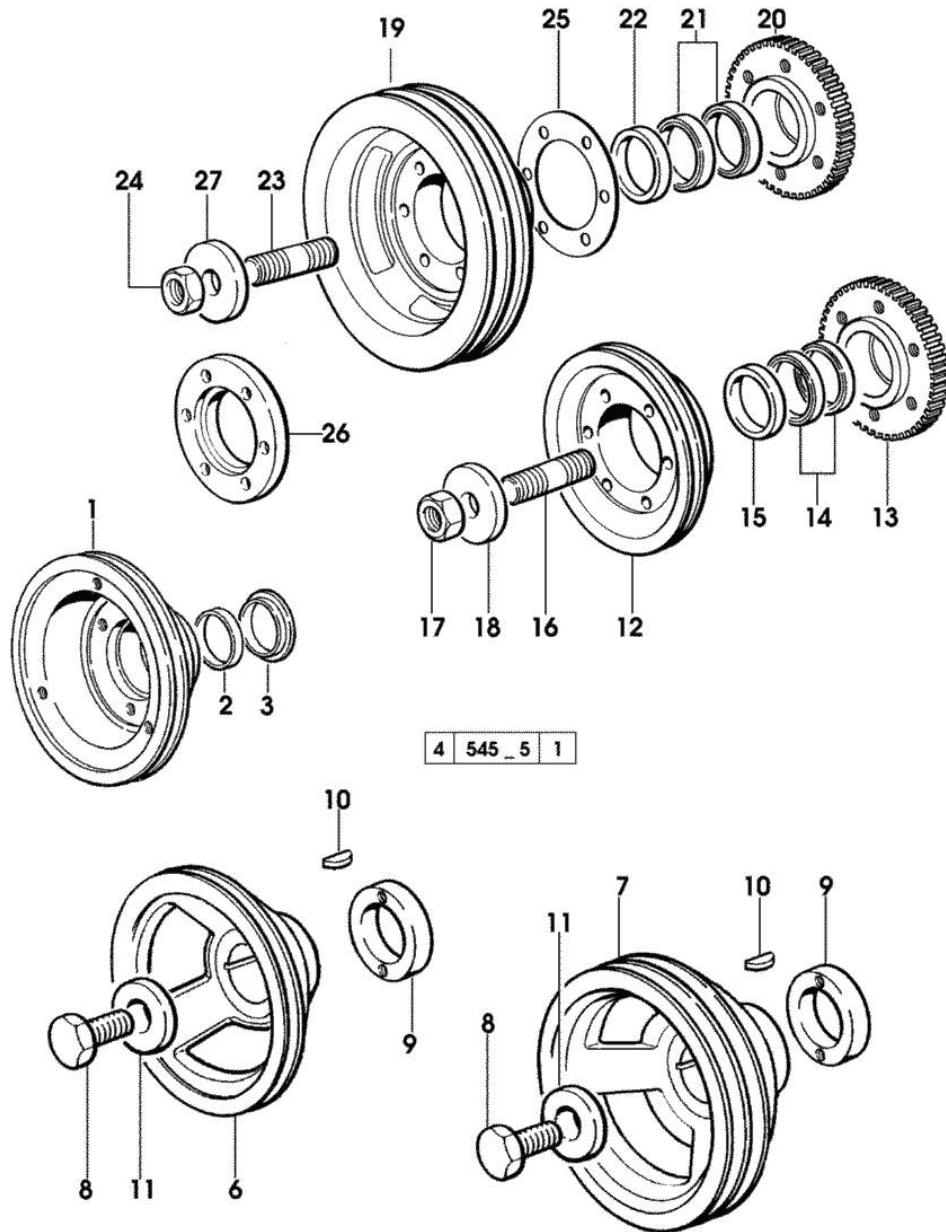

ENGINE SHAFT - PULLEYS

Fig.	P/n	QTY	Name
24	2.1019.094.7	1	nut m 20 p.1.5
25	2.1589.137.0	3	shoulder ring 71x110x1
26	0.089.1253.0/10	1	spacer
27	2.1599.524.7	1	washer 21x60x12

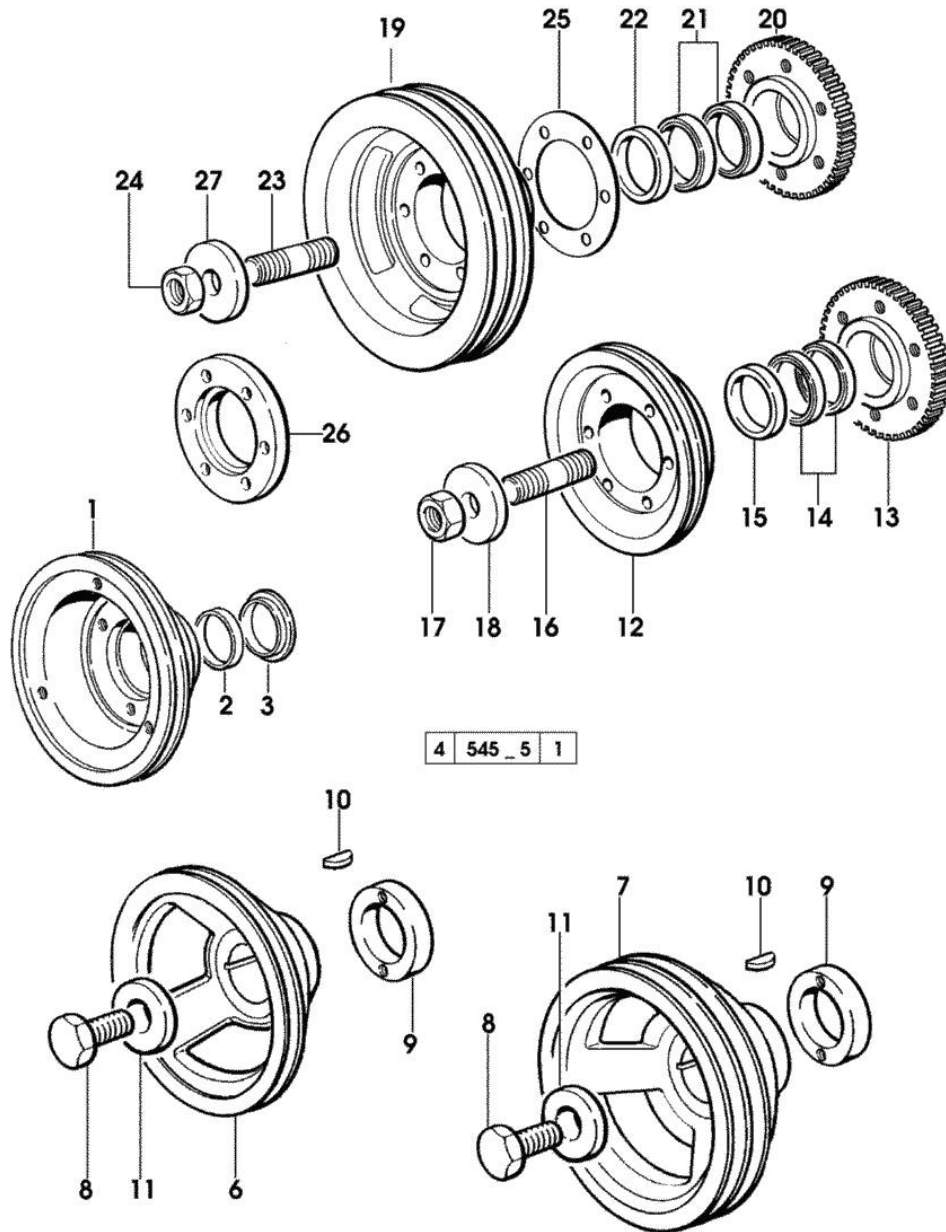

Section: ENGINE

COUNTERWEIGHTS

Fig.	P/n	QTY	Name
------	-----	-----	------

Notes:
[H-478 PRESTIGE]

1	0.086.1233.3/30	1	mass sx/lh/li
2	2.1559.115.0	2	special bushing 26x30x30
3	2.1652.302.0	1	roll pin 4x6
4	0.000.0000.1		cannot be supplied
5	0.065.1233.3/30	1	mass dx/rh/re
6	2.1410.018.7	1	circlip 45
7	2.1652.302.0	1	roll pin 4x6
8	2.1559.115.0	2	special bushing 26x30x30
9	0.000.0000.1		cannot be supplied
10	2.1589.185.0	4	shoulder ring 26.1x34x1
11	2.1631.717.0	2	roll pin 8 x 40
12	0.086.1231.0/10	1	box
13	2.3130.001.1	4	plug 1/8" gas
14	2.0139.028.2	4	screw m 12
15	2.1579.628.0	2	spacer 16.5x26x0.1
15	2.1589.048.0	2	shoulder ring 16.5x26x0.3
16	2.1579.629.0		spacer 12.5x26x0.1
16	2.1589.049.0		shoulder ring 12.5x26x0.3
17	2.1579.626.0	2	spacer 13.2x16x11
18	2.1589.139.0	2	shoulder ring mm 0.3
19	2.1589.140.0	2	shoulder ring mm 0.1
20	2.1699.191.0	1	bush 7x10x16
21	0.065.1234.0/10	2	shaft
22	2.3130.001.1	2	plug 1/8" gas

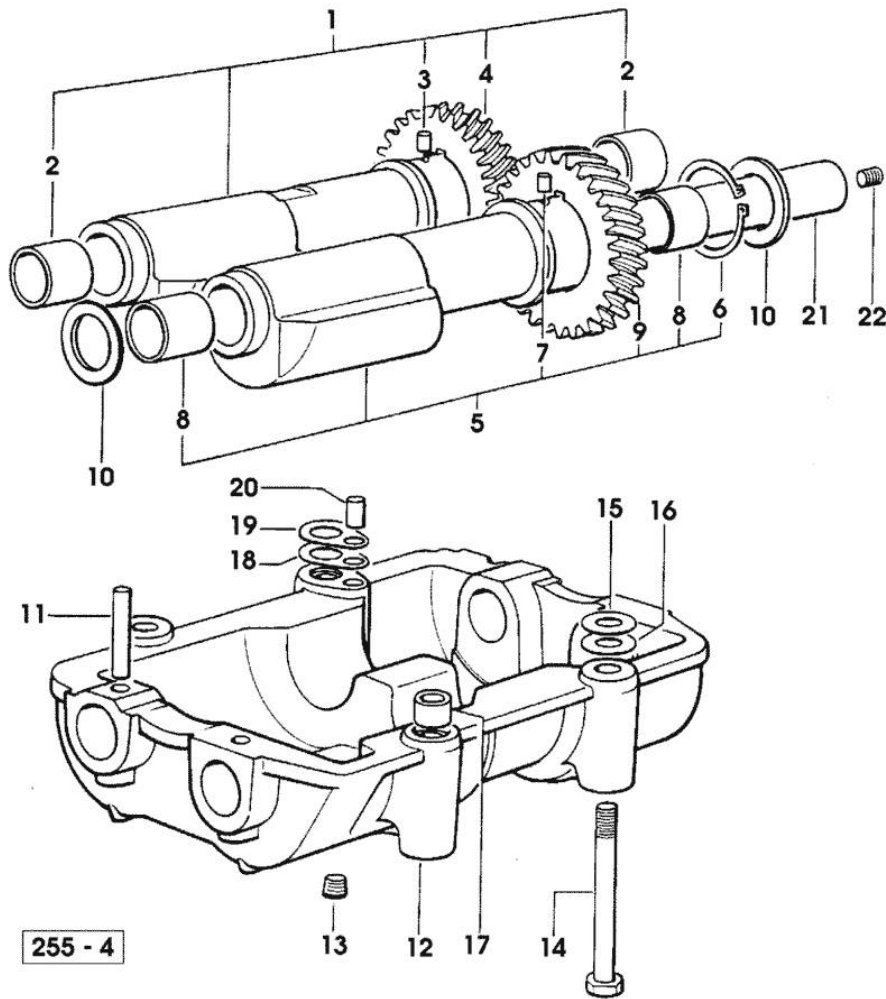

Section: ENGINE

CAMSHAFT

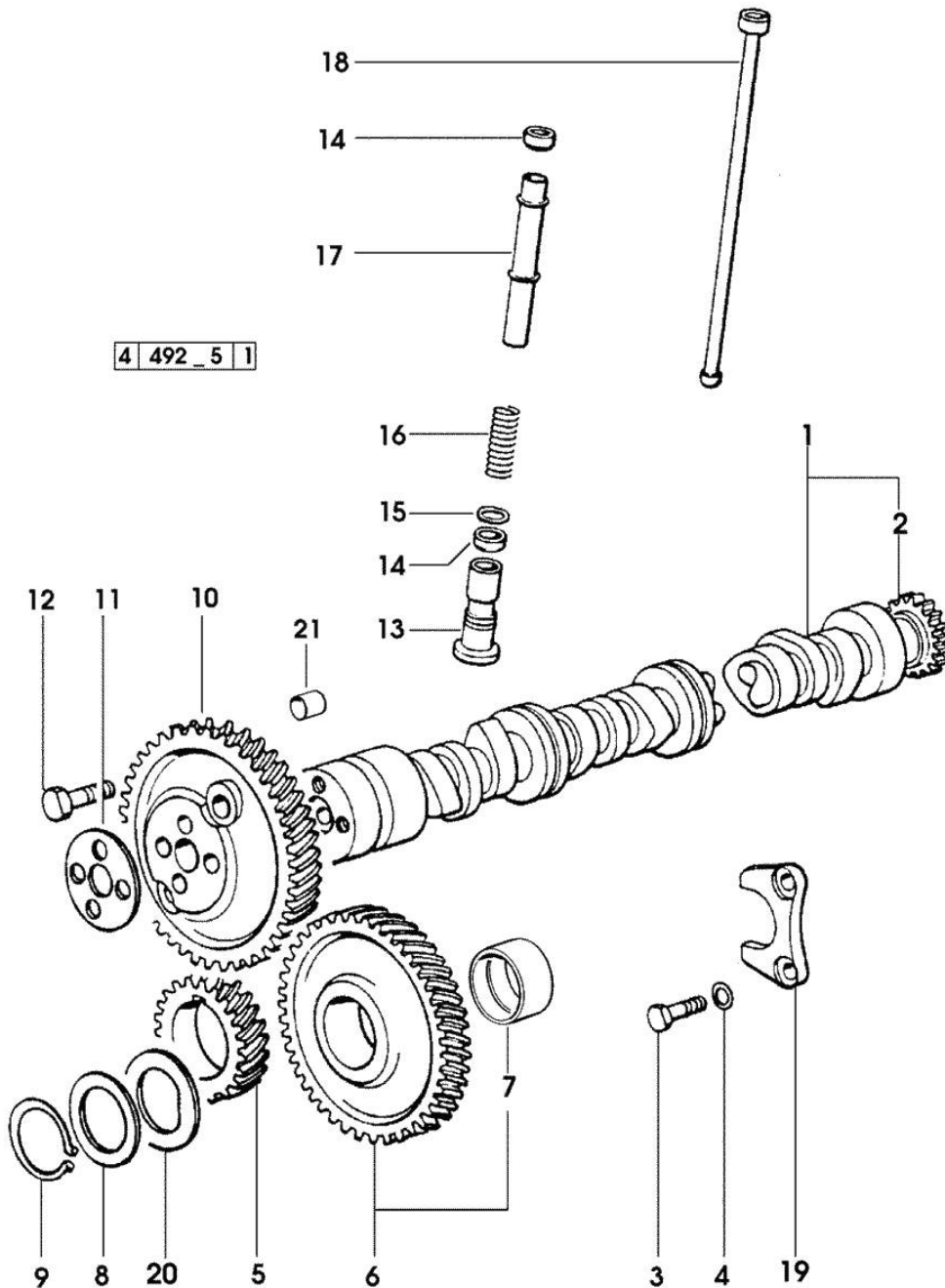

Fig.	P/n	QTY	Name
------	-----	-----	------

Notes:
[H-478 PRESTIGE]

1	0.007.1712.3/10	1	camshaft - EXPORT U.S.A.
1	0.066.1310.3/40	1	camshaft
2	0.065.1324.0/10	1	gear Z = 32
3	2.0312.206.2	2	screw m 8 p 1.25 x 20
4	2.1480.014.1	2	washer 8
5	0.065.1323.0/30	1	gear Z = 29
6	0.007.1177.3/10	1	gear z = 57 - WITH RED IDENTIFICATION STAMP
6	0.007.1178.3/10	1	gear z = 57 - WITH YELLOW IDENTIFICATION STAMP
6	0.007.1179.3/10	1	gear z = 57 - WITH GREEN IDENTIFICATION STAMP
7	2.1559.185.0/10	1	bushing
8	0.065.1352.0	1	shim
9	2.1410.016.1	1	circlip 40
10	0.065.1354.0/20	1	gear z=58
11	0.065.1350.0	1	small disc
12	2.0132.207.2	4	screw m 10 p.1 x 25
13	0.065.1330.0	8	tappets
14	2.1569.114.0/10	16	gasket 14x18.5x8
15	2.1599.437.0	8	shoulder ring
16	2.4019.300.1/10	8	spring 18.5x52x2
17	0.065.1332.0	8	sleeve
18	0.065.1331.2	8	rod
19	0.065.1353.0	1	small plate
20	0.065.1351.0	2	shoulder ring
21	2.1559.398.0	1	bushing 10.5x13x12

Section: ENGINE
CYLINDER HEAD

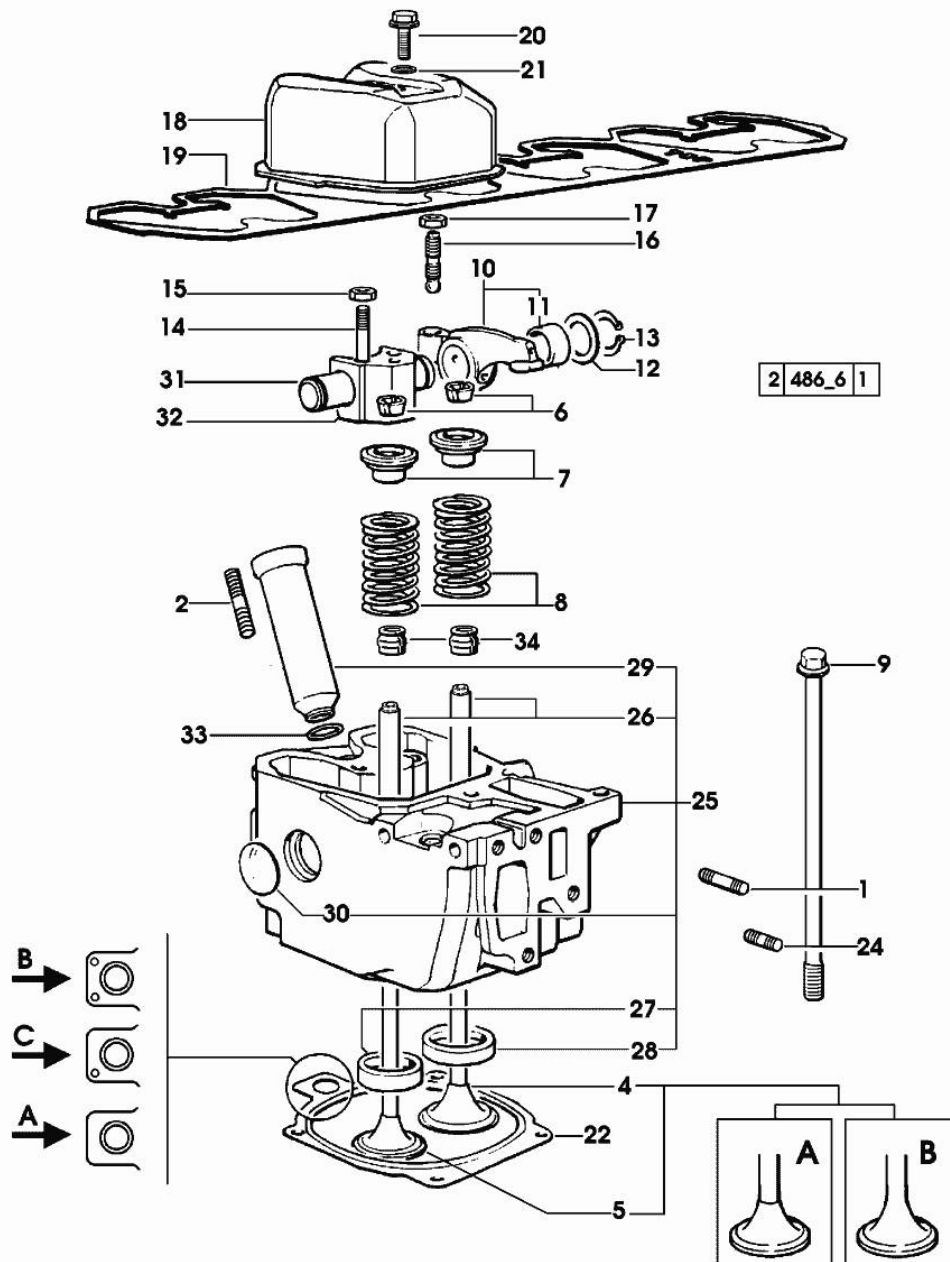
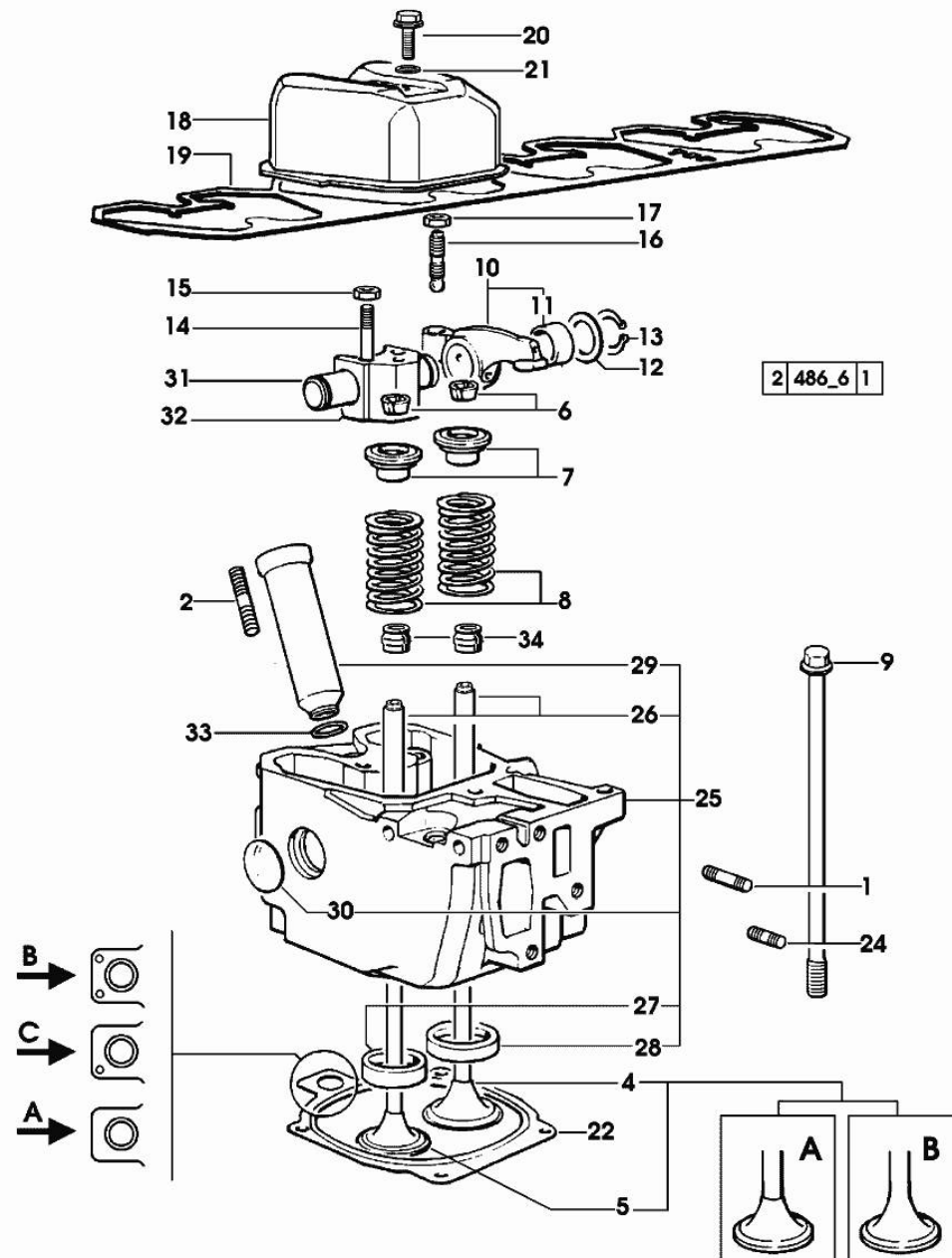

Fig.	P/n	QTY	Name
Notes: [H-478 PRESTIGE]			
1	2.0432.011.7	4	stud bolt m 8 p.1.25 / p.1 x 40
2	2.0432.161.7	4	stud bolt m 10 p.1.5 / p.1.25 x 40
4	0.010.6016.0	4	inlet valve mm 43.63 / Ø mm 9 - X H 468 - H 478
4	0.010.6017.0	4	inlet valve mm 43.63 / Ø mm 9 - X H 488T -> (...) = B
4	0.081.1420.0	4	inlet valve Ø mm 9 - X H 488T (...) <= A
5	0.010.6022.0	4	exhaust valve mm 39.1 / Ø mm 9 - X H 488T -> (...) = B
5	0.066.1421.0	4	exhaust valve - X H 468 - H 478 - X H 488T (...) <= A
6	0.074.1423.0	16	conical valve cotter
7	0.066.1425.0	8	cup
8	2.4019.287.0	8	spring
9	0.066.1443.0/10	16	screw
10	0.066.1432.3	8	rocker arm
11	2.1559.021.0/40	8	bushing 15x19x22
12	2.1599.432.0	8	shoulder ring
13	2.1410.055.1	8	circlip 19
14	2.0432.163.7	8	stud bolt m 10 p.1.5 / p.1.25 x 45
15	2.1011.321.2	8	nut m 10 p.1.25
16	0.021.1434.0	8	screw
17	2.1011.405.2	8	nut m 8 p.1
18	0.007.1139.0/10	4	small cap * (...) <= - N.4 - 2.0399.130.2/10
19	0.065.1450.0/30	1	tappet gasket
20	2.0399.130.2	4	screw m 8 x 30 (...) <= screw m 8x36x44 => (...)
20	2.0399.130.2/10	4	
21	2.1569.170.0/10	4	gasket 8.2 x 14
22	0.078.1451.0/40	1	head gasket -A-
22	0.078.1452.0/30	1	head gasket -B-
22	0.078.1453.0/40	1	head gasket -C-
24	2.0432.005.7	4	stud bolt m 8 p.1.5 / p.1 x 25
25	0.007.1360.3/60	4	head - X H 488T -> (...) = B
25	0.012.2693.3/10	4	engine head

Section: ENGINE
CYLINDER HEAD

Fig.	P/n	QTY	Name
------	-----	-----	------

			- X H 468 - H 478
			- X H 488T (...) <- = A
26	0.007.1779.0/10	8	valve guide
27	0.066.1427.0	4	valve seat
28	0.078.1426.0	4	valve seat
29	0.010.6041.0	4	bush
30	2.3170.012.1	8	expansion plug 30
31	0.066.1431.0	4	pin
32	0.066.1430.0/10	4	support
33	2.1530.051.0	4	oil seal 20.22x3.53
34	2.1519.117.0	8	special oil seal



Section: ENGINE
LUBRICATION

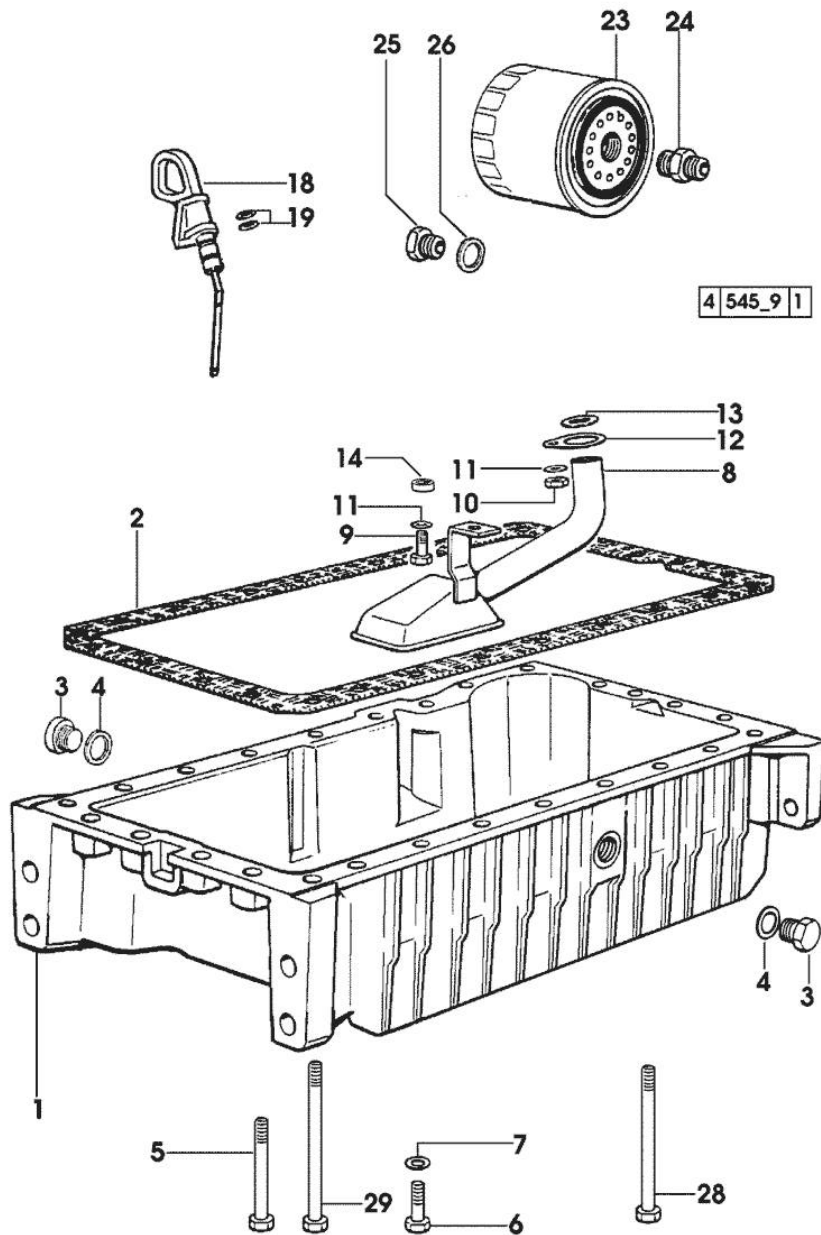

Fig.	P/n	QTY	Name
Notes: [H-478 PRESTIGE]			
1	0.007.1277.0/40	1	oil sump
2	0.065.1550.0/10	1	gasket
3	2.3199.001.2	2	plug 1/2" gas
4	2.1560.054.0	2	gasket 21 x 26
5	2.0112.226.2	4	screw m 8 p.1.25 x 85
6	2.0112.215.2	17	screw m 8 p.1.25 x 40
7	2.1470.004.2	26	lock washer 8
8	0.065.1531.3/20	1	tube
9	2.0112.205.2	1	screw m 8 p.1.25 x 16
9	2.0112.209.2	1	screw m 8 p 1.25 x 25 (...) <= => (...)
10	2.1011.105.2	1	nut m 8 p.1.25
11	2.1470.004.2	2	lock washer 8
12	0.065.1538.0	1	flange
13	2.1539.040.0	1	special oil seal 21.82 x 3.53
14	2.1579.766.2	1	spacer 8.5x16x10 => (...)
18	0.086.1513.2/30	1	dipstick
19	2.1539.065.0	2	special oil seal 8.73 x 1.78
23	0.044.1567.0	1	oil filter element - X H 468 - H 478
23	2.4419.340.0	1	oil filter element - X H 488T
24	2.3339.307.0	1	pipe fitting m 22 p.1.5-3/4"
25	2.3339.353.2/20	1	pipe fitting 12 p.1.5-18 p.1.5 - X H 468 - H 478
26	2.1560.014.0	1	washer 18.2 x 24 - X H 468 - H 478
28	2.0112.235.2	3	screw m 8 p.1.25 x 130
29	2.0112.239.2	2	screw m 8 p.1.25 x 150



Suggest:

For more complete manuals. Please go to the home page.

<https://www.ebooklibonline.com>

If the above button click is invalid. Please download this document first, and then click the above link to download the complete manual.

Thank you so much for reading

Section: ENGINE
LUBRICATION

Fig.	P/n	QTY	Name
------	-----	-----	------

Notes:
 [H-478 PRESTIGE]

1	0.078.1554.3	1	box
2	0.066.1750.0	1	tube
3	2.1560.014.0	1	washer 18.2 x 24
4	2.3120.101.0	1	plug m 18 p.1.5
5	0.078.1557.0/10	2	gasket
6	0.078.1556.0/10	1	gasket
7	0.078.1555.0/10	1	plate
8	2.1310.004.2	8	flat washer 8.4x17
9	2.0112.205.2	8	screw m 8 p.1.25 x 16
10	2.1480.014.1	4	washer 8
11	2.0312.217.2	2	screw m 8 p.1.25x55
12	2.0312.220.2	2	screw m 8 p.1.25x70
13	2.1539.048.0	1	special oil seal 20.35x1.78
14	2.1539.050.0	1	special oil seal 69.57x1.78
15	0.078.1540.3	1	radiator

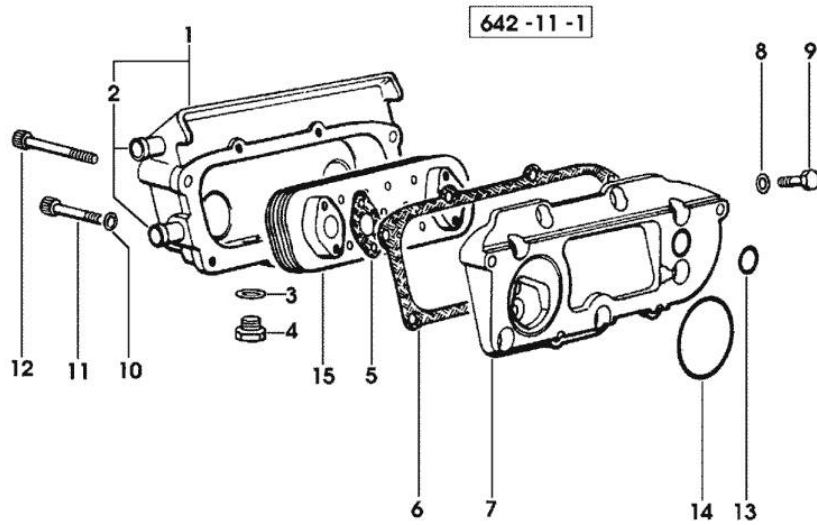

Section: ENGINE
LUBRICATION

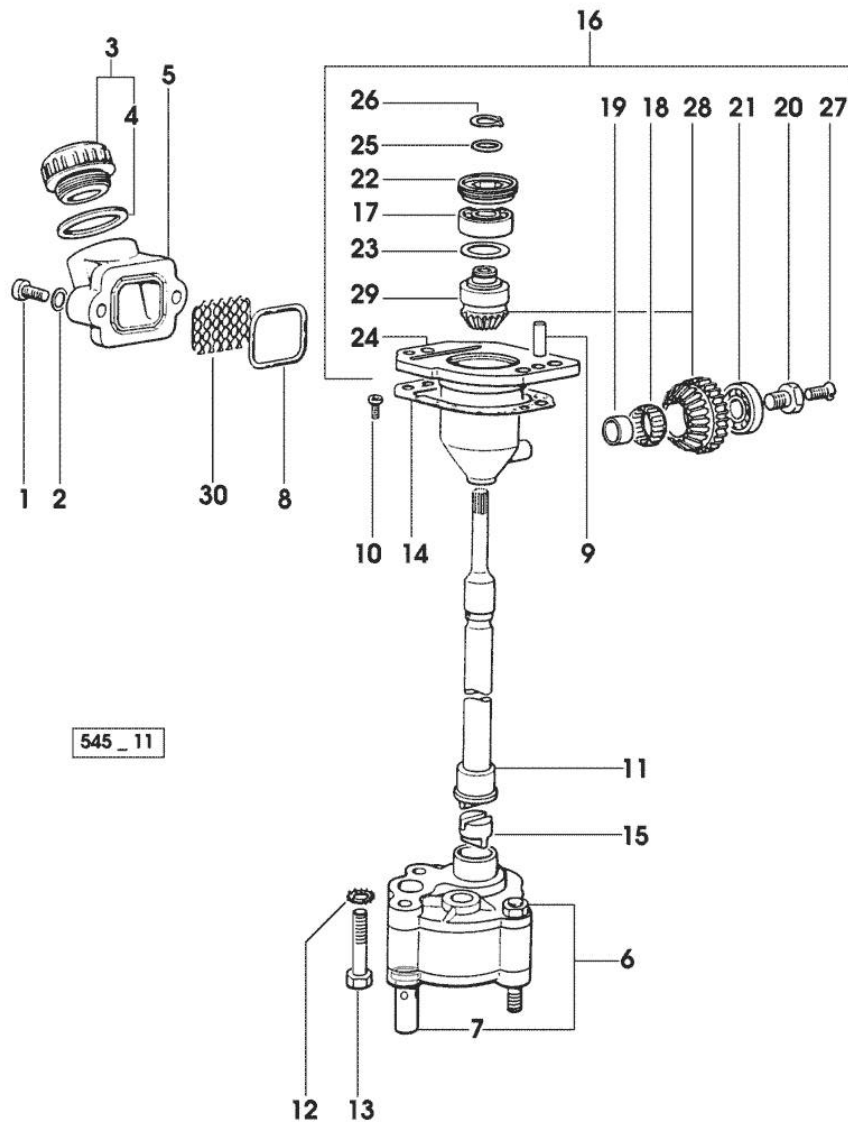

Fig.	P/n	QTY	Name
------	-----	-----	------

Notes:
[H-478 PRESTIGE]

1	2.0312.206.2	2	screw m 8 p 1.25 x 20
2	2.1480.014.1	2	washer 8
3	0.041.1135.4	1	plug 1" gas
4	2.1569.072.0	1	gasket 32 x 39.5 x 2
5	0.065.1565.0/10	1	pipe union
6	0.010.5441.4/10	1	oil pump
			- X H 468 - H 478 - H 488T
6	0.010.5481.4	1	oil pump
			- X H 358
7	0.065.1552.3/60	1	valve
8	2.1539.042.0	1	special oil seal 47.35x1.78
9	2.1651.711.0	2	pin 8 x 14
10	2.0169.005.2	2	screw m 6 p.1 x 12
11	0.065.1569.0/40	1	shaft
12	2.1470.006.2	2	lock washer 10
13	2.0112.325.2	2	screw m 10 p.1.5 x 80
14	0.065.1560.0/20	2	gasket
15	0.065.1562.0/10	1	joint
16	0.075.1551.4/20	1	support
17	2.2020.001.0	1	ball bearing 15 x 32 x 8.00
18	2.2725.016.0	1	roller cage 15 x 21 x 12
19	2.2680.020.0	1	ring 12 x 15 x 12
20	2.0399.128.2	1	screw
			(...) <=
20	2.0399.128.2/10	1	screw m 8 p.1 x 8
			=> (...)
21	2.2030.002.0	1	ball bearing 12 x 28 x 8
22	2.1219.025.2	1	ring nut m 36 p.1
			(...) <=
22	2.1219.025.2/10	1	ring nut m 36 p.1.5
			=> (...)
23	2.1589.148.0	1	shoulder ring 28.2 x 31.8 x 0.5
23	2.1589.150.0		shoulder ring 28.2 x 31.8 x 0.1
23	2.1589.151.0		shoulder ring 28.2 x 31.8 x 0.15
24	0.075.1551.3/30	1	support
			* (...) <=
			- N.1 - 2.1519.025.2/10 - 2.0399.128.2/10
25	2.1589.146.0		shoulder ring 15.2 x 19 x 0.15
25	2.1589.147.0		shoulder ring 15.2 x 19 x 0.10
25	2.1589.153.0	1	shoulder ring 15.2 x 19 x 1.00
26	2.1410.057.1	1	circlip 15

<https://www.ebooklibonline.com>

Hello dear friend!

Thank you very much for reading.

Enter the link into your browser.

The full manual is available for immediate download.

<https://www.ebooklibonline.com>