

Section: ENGINE
CRANKCASE

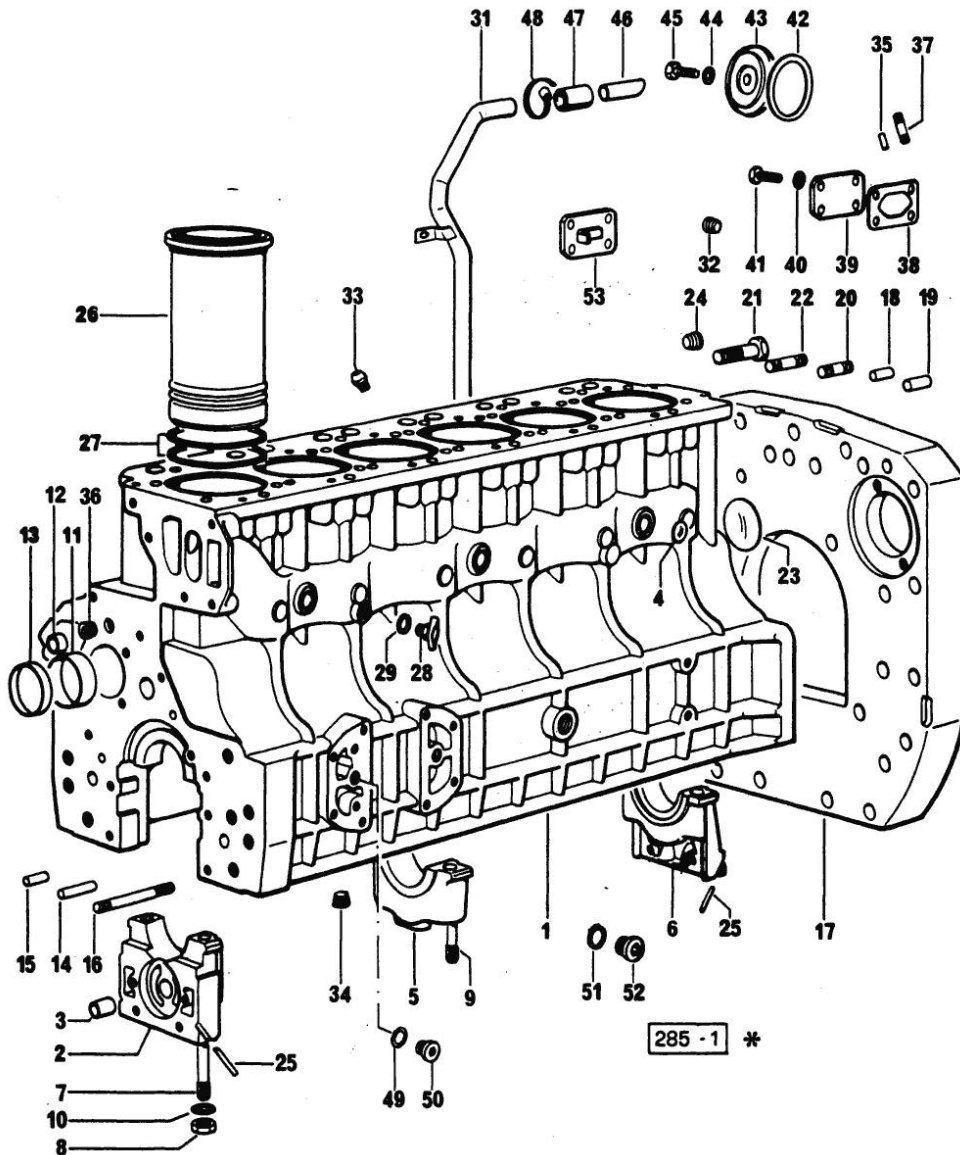

Fig.	P/n	QTY	Name
Notes: [H 6170 T]			
0	0.064.0050.6	1	gasket set - FOR ENGINE MOUNTING
1	0.061.1110.4/70	1	crankcase (...) <= ORDER ALSO: 1x 0.045.1240.0 - 2x 2.0112.309.2 - 9x 2.1474.010.2
2	0.003.8318.0	1	support
3	2.1559.090.0/10	1	bushing 14.24x19.06x27
4	2.3170.012.1	5	expansion plug 30
5	0.052.1113.0	5	support
6	0.052.1116.0	1	support
7	0.052.1151.0	4	stud bolt
8	2.1099.064.7	14	special nut
9	0.052.1150.0	10	stud bolt
10	2.1599.318.7	14	flat washer
11	2.1559.156.0	4	special bushing
12	2.1559.111.0/10	2	special bushing 11.5x14.1x10
13	2.1559.157.0	1	special bushing
14	2.1699.114.0	1	pin 8x55
15	2.1653.711.0	1	pin
16	2.0432.025.7	2	stud bolt m 8 p.1.25 - 1.00 x 100
17	0.071.1150.0	1	flange
18	2.1653.708.0	2	pin 8x18 (...)<=
19	2.1652.911.0	2	cylindrical plug 12x25
20	2.0432.153.7	2	stud bolt m 10 p.1.5 / p.1.25 x 20
21	2.0112.513.1	10	screw m 14 p.2 x 35
22	2.0432.257.7	2	stud bolt m 12 p.1.75 - 1.25 x 30
23	2.3170.023.1	1	expansion plug 65
24	2.3130.003.1	2	plug 3/8" gas
25	0.029.1154.0/10	4	gasket
26	0.057.1120.0	6	engine cylinder
27	2.1539.029.0	12	special oil seal
28	0.049.1152.0	1	cock
29	2.1560.009.0	1	gasket 14.2x18
31	0.079.1150.2/20	1	tube
32	2.3130.002.1	2	plug 1/4" gas
33	0.071.1151.3	6	valve
34	2.3130.001.1	6	plug 1/8" gas
35	2.1652.306.0	2	cylindrical plug 4x14
36	2.3139.001.1	6	plug
37	2.0432.003.7	8	stud bolt m 8 p.1.25 / p.1 x 20

Section: ENGINE
CRANKCASE

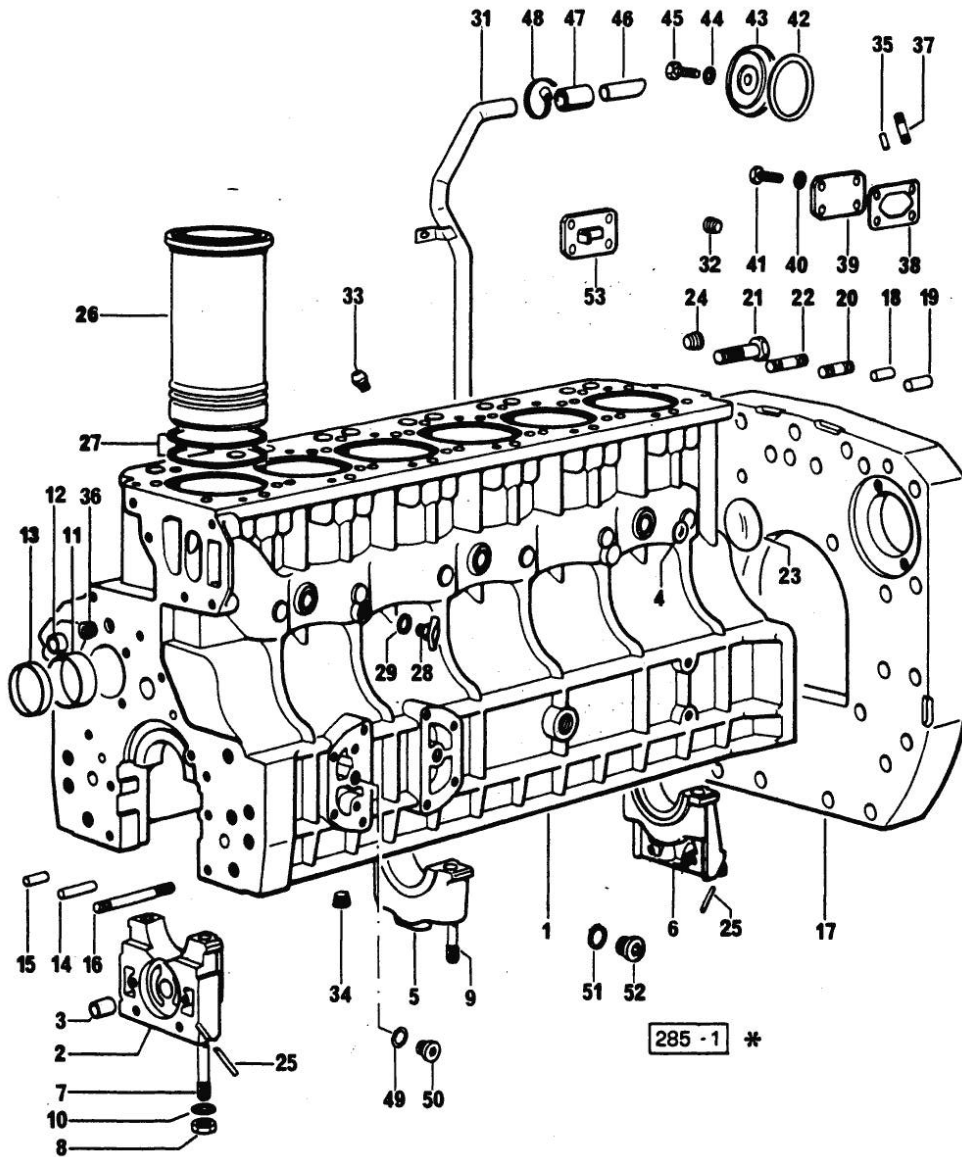

Fig.	P/n	QTY	Name
38	0.057.1153.0	2	gasket
39	0.057.1152.0/10	1	cover
40	2.1310.004.2	8	flat washer 8.4x17
41	2.0112.205.2	8	screw m 8 p.1.25 x 16
41	2.0112.207.2	4	screw m 8 p 1.25 x 20
41	2.0119.123.2	4	screw
42	0.057.1151.0	1	gasket (...)<=
42	0.064.1155.0	1	gasket =>(…)
43	0.064.1153.0	1	cover (...)<=
ORDER ALSO 1x 2.0112.215.2 - 1x 0.064.1155.0			
44	2.1560.003.0	1	copper gasket 8.2 x 12
45	2.0112.204.2	1	screw m 8 p.1.25x14
45	2.0112.215.2	1	screw m 8 p.1.25 x 40
46	0.064.1154.0	1	tube
47	0.057.1158.0	1	sleeve
48	2.6850.007.0	1	clamp 25-40
49	2.1560.014.0	1	washer 18.2 x 24
50	2.3120.001.4	1	plug m 18 p.1.5
51	2.1560.017.0	1	gasket 22.2 x 27
52	2.3120.002.4	1	plug m 22 x 1.5
53	0.057.1162.3/20	1	cover

Section: ENGINE
TIMING CASE

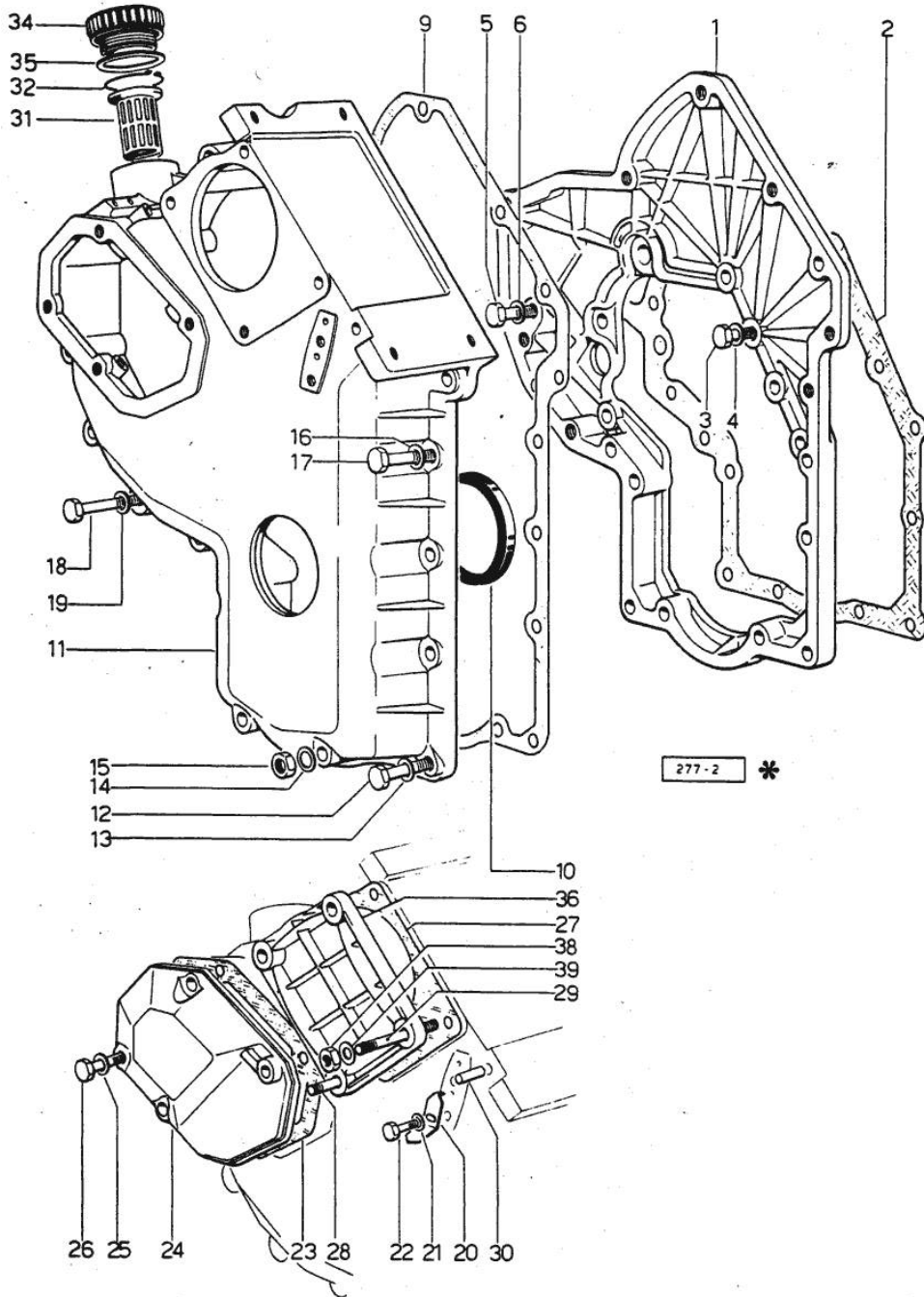

Fig.	P/n	QTY	Name
------	-----	-----	------

Notes:
[H 6170 T]

1	0.079.1131.0	1	flange
2	0.057.1155.0	1	gasket
3	2.0112.209.2	2	screw m 8 p 1.25 x 25
4	2.1480.014.1	4	washer 8
5	2.0112.207.2	3	screw m 8 p 1.25 x 20
6	2.1474.009.1	1	spring washer 8
6	2.1480.014.1	2	washer 8
9	0.041.1152.0	1	gasket
10	2.1519.010.0	1	special oil seal 58x80x10
11	0.048.1132.0/40	1	guard
12	2.0112.217.2	5	screw m 8 p.1.25 x 45
13	2.1480.014.1	5	washer 8
14	2.1560.003.0	2	copper gasket 8.2 x 12
15	2.1011.405.2	2	nut m 8 p.1
16	2.1480.014.1	3	washer 8
17	2.0112.211.2	3	screw m 8 p.1.25 x 30
18	2.0112.222.2	4	screw m 8 p.1.25x65
19	2.1480.014.1	4	washer 8
20	0.057.1156.0	1	index
21	2.1310.004.2	1	flat washer 8.4x17
22	2.0112.204.2	1	screw m 8 p.1.25x14
23	0.048.1151.0/10	1	gasket
24	0.048.1150.0/20	1	cover
25	2.1560.006.0	4	gasket 10.2 x 16
26	2.0112.315.2	4	screw m 10 p.1.5 x 40
27	0.041.1154.0	1	gasket
28	2.0432.013.7	1	stud bolt m 8 p.1.25 / p.1 x 45
29	2.0432.028.7	3	stud bolt m 8 p.1.25-1x130
30	2.1653.717.0	1	pin 8 x 40
31	0.041.1159.0/10	1	filter
32	2.1411.012.1	1	circlip 30
34	0.041.1135.4	1	plug 1" gas
35	2.1569.072.0	1	gasket 32 x 39.5 x 2
36	0.037.1151.0/10	1	cover
38	2.1011.405.2	4	nut m 8 p.1
39	2.1310.004.2	4	flat washer 8.4x17

<https://www.ebooklibonline.com>

Hello dear friend!

Thank you very much for reading.

Enter the link into your browser.

The full manual is available for immediate download.

<https://www.ebooklibonline.com>

Section: ENGINE
CRANKSHAFT

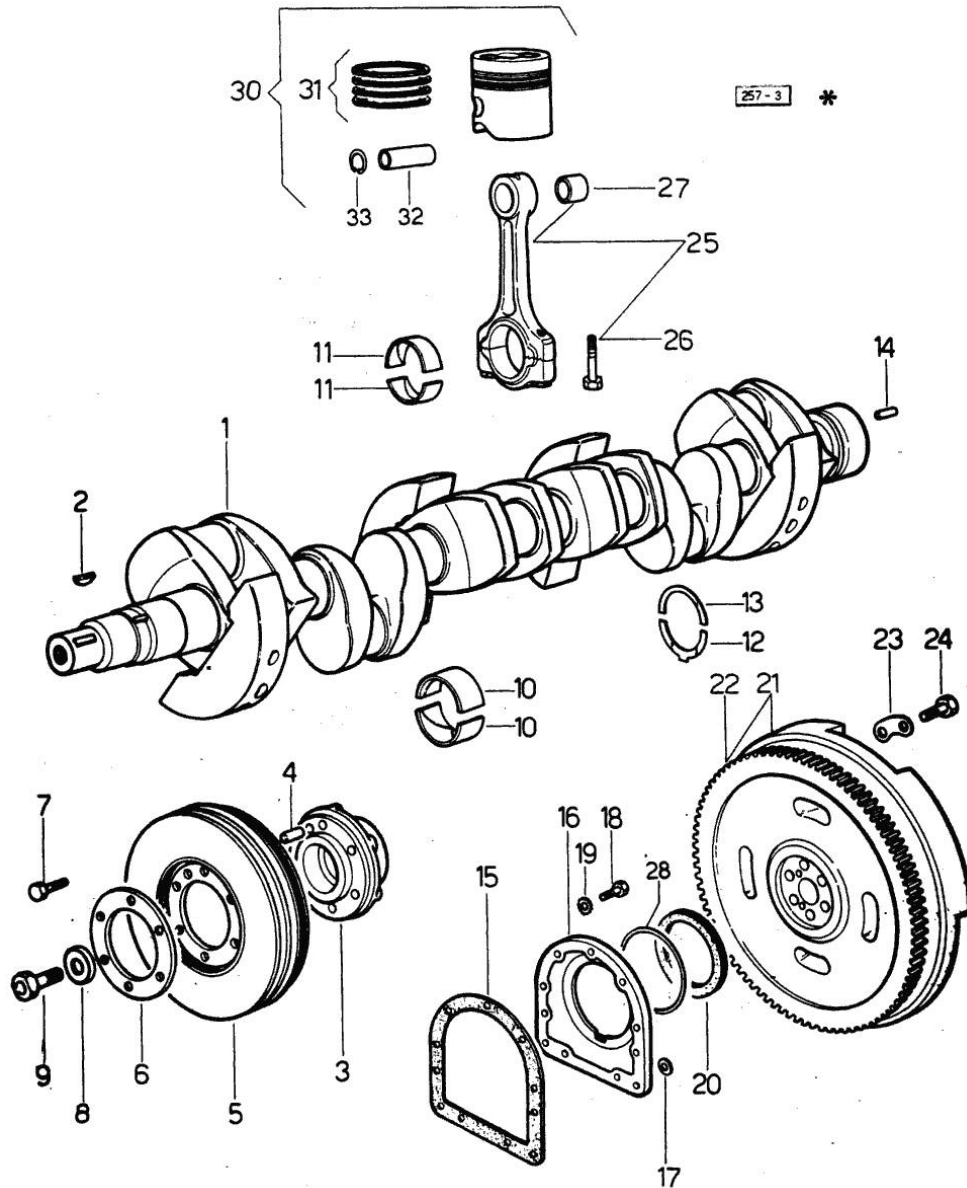

Fig.	P/n	QTY	Name
Notes:			
[H 6170 T]			
1	0.037.1210.4/30	1	crankshaft (...)<= ORDER ALSO 1x 2.1799.026.0
2	2.1799.002.0	1	stick 10x13 (...)<=
2	2.1799.026.0	1	key 10x10 =>(…)
3	0.037.1250.0/10	1	hub
4	2.1651.909.0	1	cylindrical plug 12 x 20
5	0.047.1246.3	1	antivibration pulley 153<-
5	0.071.1246.3/10	1	antivibration pulley ->154
6	0.037.1255.0	1	flange
7	2.0122.461.1	6	screw m 12 p.1.25x30
8	0.001.6020.0	1	shoulder
9	2.0129.032.2	1	screw m 24 p.2x45
10	0.073.0059.0	14	main half bushing - mm 1.00
10	0.073.1215.0	14	main half bushing STANDARD
10	0.073.1215.7	14	main half bushing - mm 0.25
10	0.073.1215.8	14	main half bushing - mm 0.50
10	0.073.1215.9	14	main half bushing - mm 0.75
11	0.062.0059.0	12	con.rod half bushing - mm 1.00
11	0.062.1225.0	12	con.rod half bushing STANDARD
11	0.062.1225.7	12	con.rod half bushing - mm 0.25
11	0.062.1225.8	12	con.rod half bushing - mm 0.50
11	0.062.1225.9	12	con.rod half bushing - mm 0.75
12	0.001.4547.0	2	shoulder ring + mm 0.05
12	0.001.4548.0	2	shoulder ring + mm 0.10
12	0.001.4549.0	2	shoulder ring + mm 0.15
12	0.042.1219.0	2	shoulder ring STANDARD
13	0.001.4544.0	2	shoulder ring + mm 0.05
13	0.001.4545.0	2	shoulder ring + mm 0.10
13	0.001.4546.0	2	shoulder ring + mm 0.15
13	0.042.1218.0	2	shoulder ring STANDARD
14	2.1652.915.0	2	cylindrical plug 12x35
15	0.029.1250.0/10	1	gasket
16	0.045.1240.0	1	flange =>(…)
16	029.1240.0/10	1	- (...)<=

Section: ENGINE
CRANKSHAFT

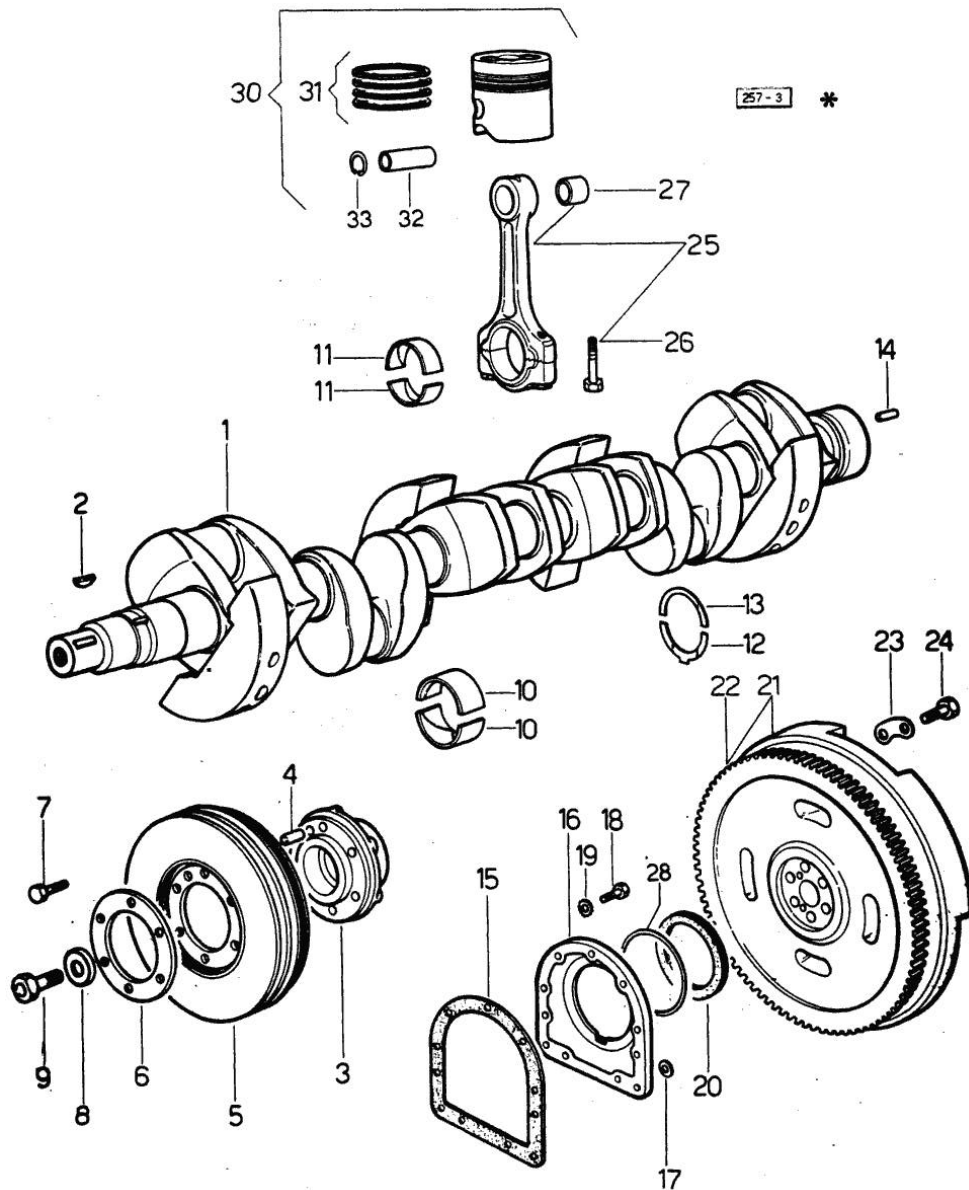
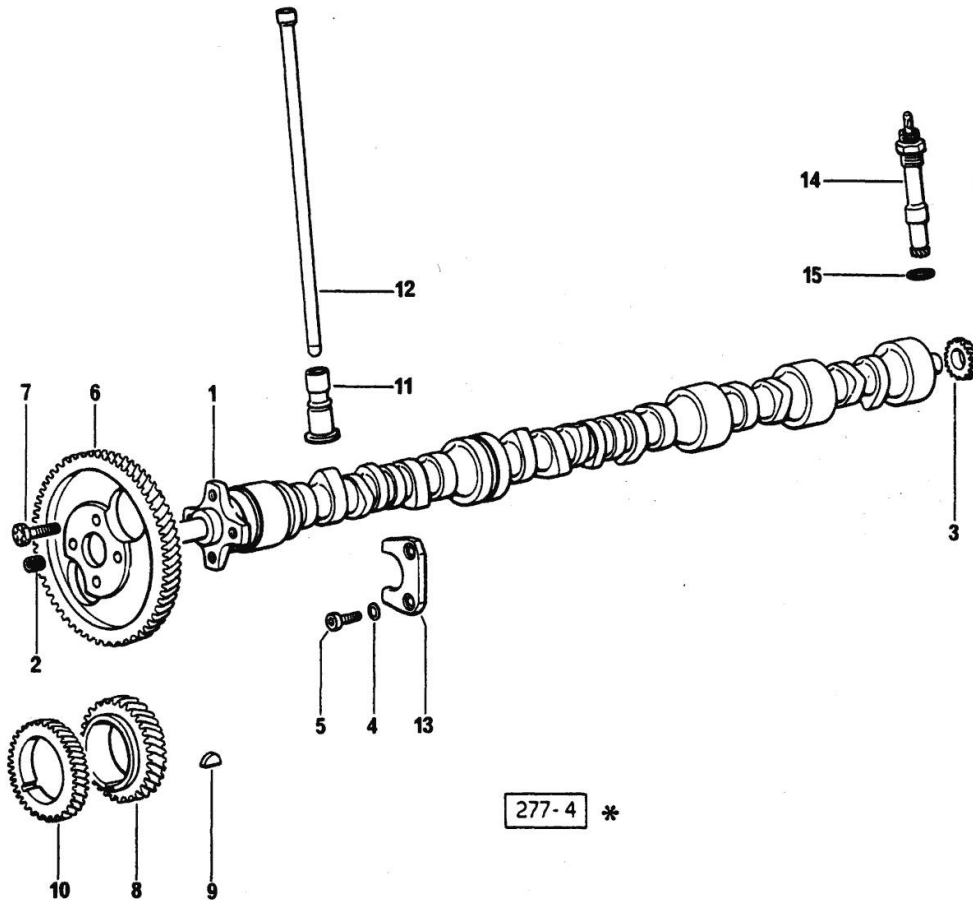

Fig.	P/n	QTY	Name
17	2.1560.006.0	2	gasket 10.2 x 16
18	2.0112.309.2	7	screw m 10 p.1.5 x 25 (...)<=
19	2.1474.010.2	9	washer 10 =>(…)
19	2.1480.015.1	7	washer 10 (...)<=
20	2.1519.009.0/10	1	special oil seal
21	0.046.1256.3	1	flywheel
22	0.047.1242.0	1	crown wheel z=128
23	2.1379.006.0	3	lock-tab 15x15x36,5
24	2.0122.517.7	6	screw m 14 p.1.5x45
25	0.057.1253.3	6	engine connecting rod
26	0.039.1250.0	12	screw m 14 p.1.5x63
27	2.1559.144.0	6	old part number
28	2.1599.404.0	1	shoulder ring
30	0.064.0060.6	6	complete piston STANDARD
31	0.057.0051.6	6	piston ring set
32	0.057.1236.0	6	piston pin
33	2.1411.016.1	12	circlip 40

Section: ENGINE

CAMSHAFT



277-4 *

Fig.	P/n	QTY	Name
------	-----	-----	------

Notes:
[H 6170 T]

1	0.057.1310.3/20	1	-
2	2.3130.001.1	1	plug 1/8" gas
3	0.041.1350.0	1	gear
4	2.1470.004.2	2	lock washer 8
5	2.0312.206.2	2	screw m 8 p 1.25 x 20
6	0.062.1321.0	1	gear z=66
7	2.0139.005.1	4	screw m 10 p.1 x 25
8	0.040.1320.0	1	gear z = 33
9	2.1720.010.0	1	key 5x9
10	0.040.1323.0/10	1	gear Z = 38
11	0.057.1330.0/10	12	tappets
12	0.057.1331.2	12	rod
13	0.057.1314.0/10	1	plate
14	0.041.1355.3	1	transmission
15	2.1560.013.0	1	gasket 18.2x22

Section: ENGINE
CYLINDER HEAD

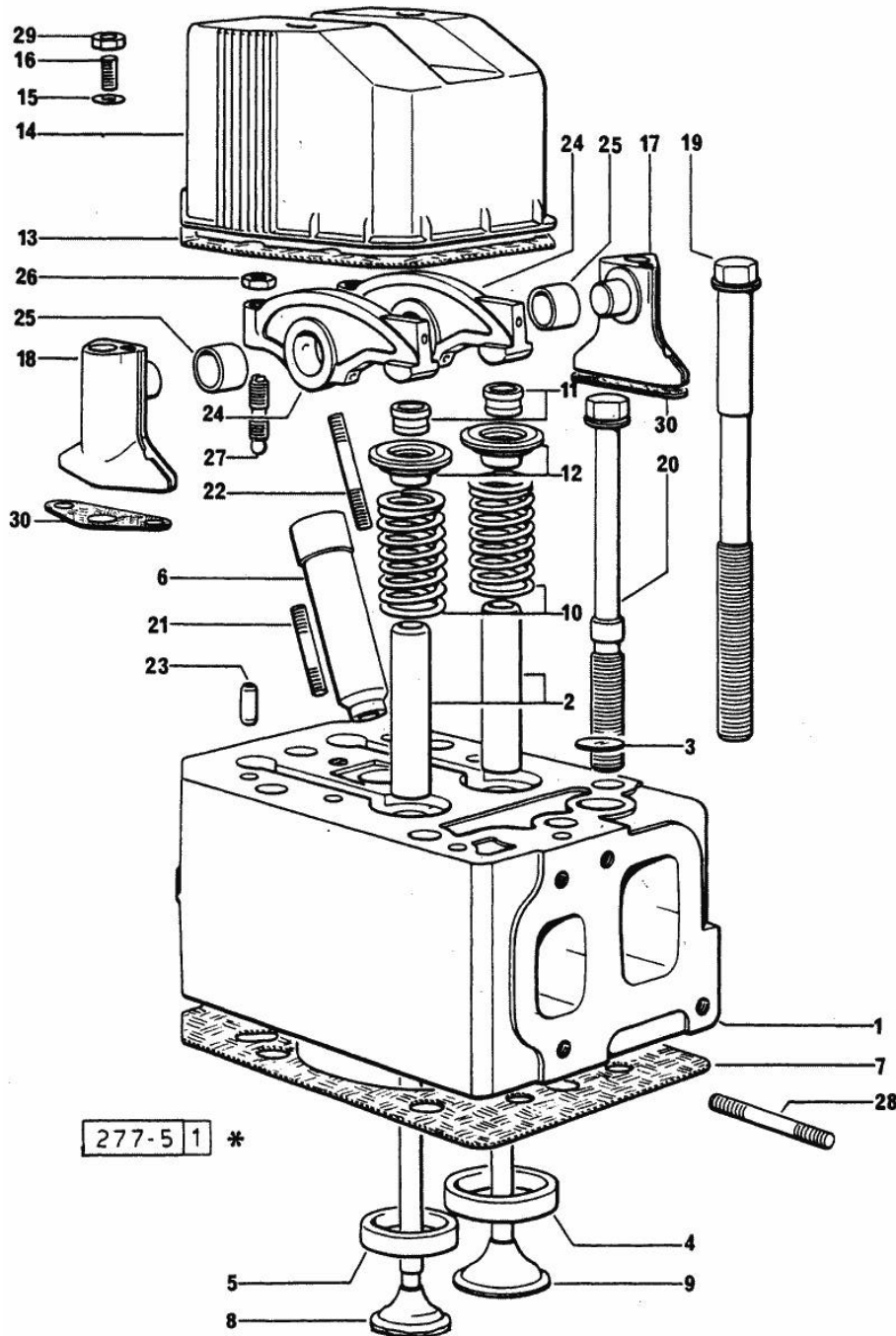

Fig.	P/n	QTY	Name
Notes: [H 6170 T]			
0	0.057.0057.6	6	gasket set - FOR 1 CYLINDER VALVE GRINDING AND PISTON RINGS REPLACEMENT
1	0.057.1410.3/70	6	engine head
2	0.057.1416.0	12	valve guide
3	2.3170.010.1	1	expansion plug 25
4	0.057.1450.0/10	6	valve seat
5	0.057.1451.0	6	valve seat
6	0.057.1452.0/10	6	bush
7	0.057.1456.0/20	6	gasket
8	0.058.1421.0/10	6	exhaust valve
9	0.058.1420.0/10	6	inlet valve
10	2.4019.228.0	12	spring
11	0.058.1423.0	12	cone
12	0.058.1425.0/10	12	cup
13	0.057.1457.0/10	6	gasket
14	0.057.1440.0/10	6	small cap
15	2.1560.004.0	12	copper gasket 8.2 x 14
16	2.0439.087.1/20	12	stud bolt m 8 p.1.25 / p.1 x 40
17	0.057.1430.0/20	6	support
18	0.057.1453.0/20	6	support
19	0.057.1454.0/10	12	screw
20	0.057.1455.0/10	24	screw
21	2.0432.007.7	6	stud bolt m 8 p.1.25 / p.1 x 30
22	2.0432.011.7	6	stud bolt m 8 p.1.25 / p.1 x 40
23	2.1652.708.0	24	cylindrical plug 8x18
24	0.057.1432.3/10	12	rocker arm
25	2.1559.141.0	12	special bushing
26	2.1011.405.2	12	nut m 8 p.1
27	0.021.1434.0	12	screw
28	2.0432.009.7	11	stud bolt m 8 p.1.25 / p. 1 x 35
28	2.0432.026.7	1	stud bolt m 8 p.1.25 - 1.00 x 110
29	2.1099.056.2	12	special nut m 8 p.1 x 8
30	0.064.1450.0	12	gasket

Section: ENGINE
LUBRICATION

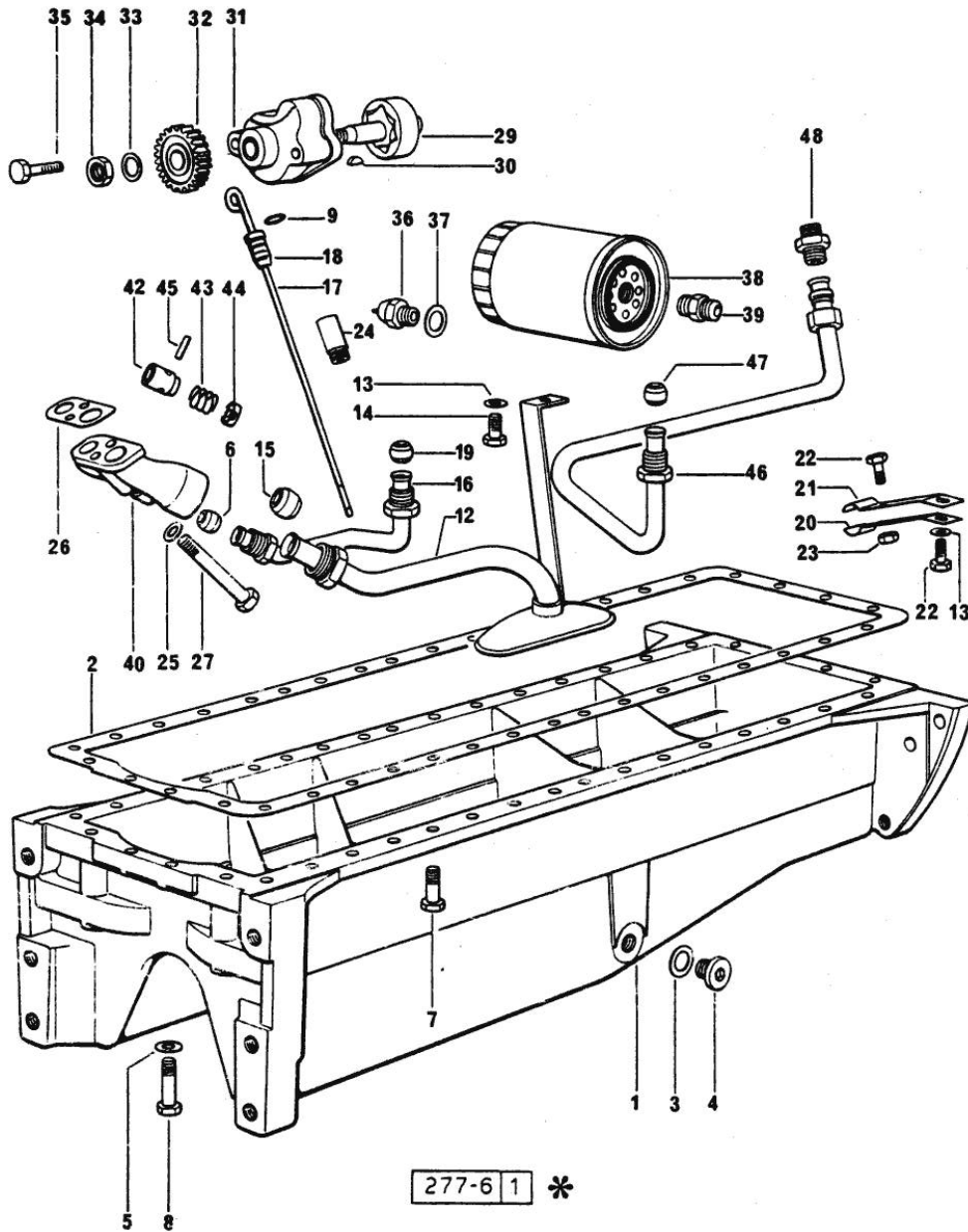

Fig.	P/n	QTY	Name
Notes: [H 6170 T]			
1	0.047.1510.0	1	oil sump
2	0.037.1512.2	1	gasket
3	2.1560.054.0	1	gasket 21 x 26
4	2.3199.001.2	1	plug 1/2" gas
5	2.1560.004.0	4	copper gasket 8.2 x 14
6	2.3359.016.1	1	nosepiece
7	2.0112.215.2	30	screw m 8 p.1.25 x 40
7	2.0112.231.1	2	screw m 8 p 1.25x110
7	2.0112.237.2	4	screw m 8 p.1.25x140
7	2.0112.244.2	2	screw m 8 p.1.25 x 180
8	2.0112.217.2	2	screw m 8 p.1.25 x 45
9	2.1539.035.0	1	special oil seal =>(…)
12	0.046.1531.3	1	tube
13	2.1310.004.2	3	flat washer 8.4x17
14	2.0112.204.2	1	screw m 8 p.1.25x14
15	2.3359.017.1	1	nosepiece
16	0.044.1560.2	1	tube
17	0.041.1513.3	1	dipstick (…)<=
17	0.057.1513.4/10	1	- =>(…)
18	0.034.1551.0	1	gasket (…)<=
19	2.3359.015.1	1	nosepiece
20	0.057.1564.0	2	bracket
21	0.057.1563.0	2	bracket
22	2.0112.207.2	4	screw m 8 p 1.25 x 20
23	2.1011.105.2	2	nut m 8 p.1.25
24	0.044.1555.0	1	spacer (…)<=
25	2.1480.014.1	2	washer 8
26	0.037.1557.0/20	1	gasket
27	2.0112.225.2	1	screw m 8 p.1.25 x 80
27	2.0112.231.1	1	screw m 8 p 1.25x110
29	0.040.1524.3/30	1	rotor
30	2.1720.005.0	1	key 4x5
31	0.047.1520.3/10	1	pump casing
32	0.040.1521.0/10	1	gear z = 27
33	2.1310.007.2	1	flat washer 13 x 24
34	2.1121.109.2	1	self-locking nut m 12 p.1.25

Section: ENGINE
LUBRICATION

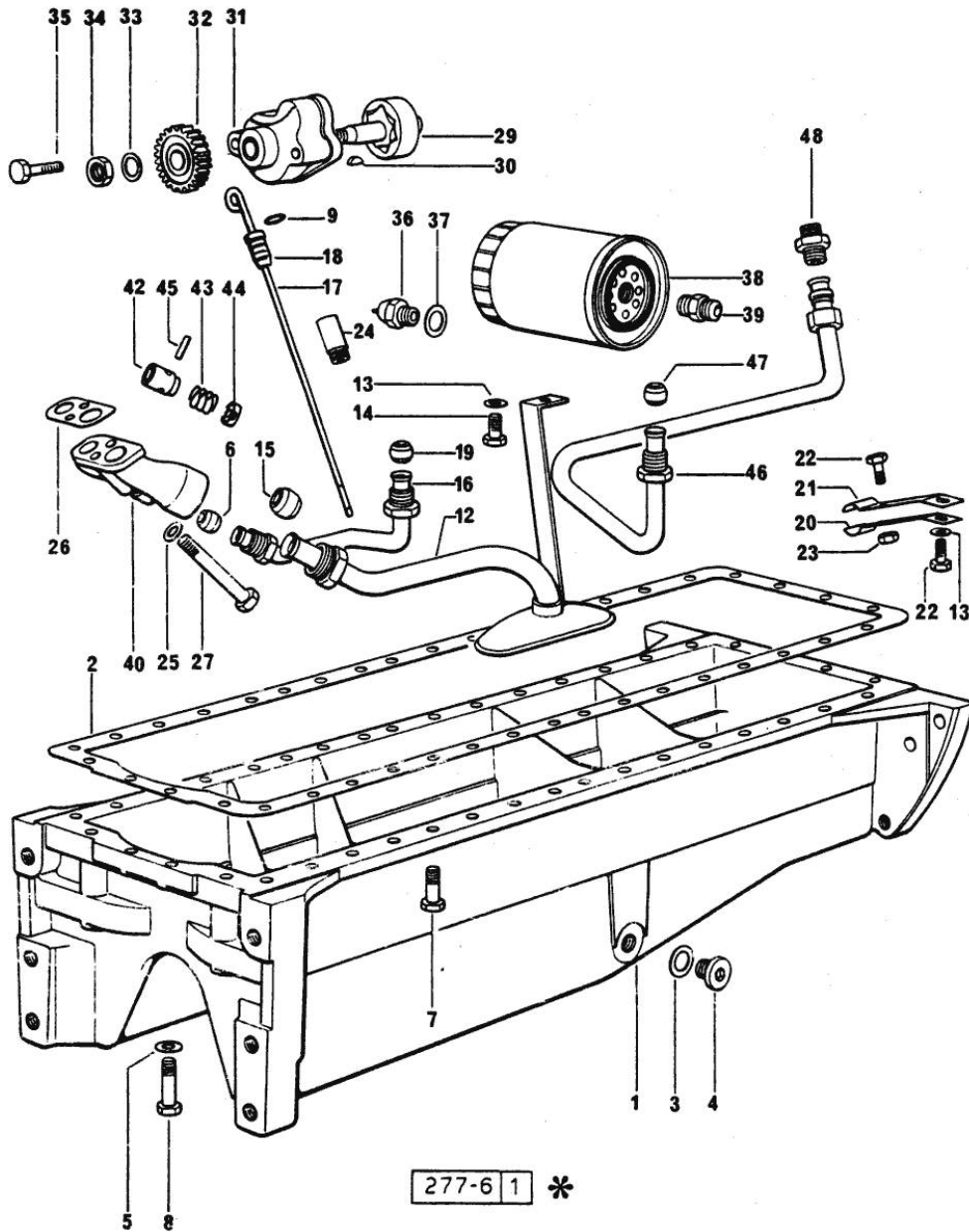

Fig.	P/n	QTY	Name
35	2.0112.219.2	2	screw m 8 p.1.25x55
36	2.7099.040.0/10	1	pressure switch
37	2.1560.008.0	1	gasket 12.2 x 18
38	0.052.1565.0	1	oil filter element
39	2.3339.094.1/10	1	pipe fitting m 20 p.1.5-3/4 gas
40	0.052.1530.0	1	tip
42	0.052.1571.0	1	small piston
43	2.4019.270.1	1	spring 9.7x54x2
44	0.054.1558.0/10	1	stop
45	2.1630.213.0	1	roll pin 3x32
46	0.061.1543.2	1	tube
47	2.3359.015.1/10	1	-
48	2.3339.159.1/10	1	pipe fitting



Suggest:

For more complete manuals. Please go to the home page.

<https://www.ebooklibonline.com>

If the above button click is invalid. Please download this document first, and then click the above link to download the complete manual.

Thank you so much for reading

Section: ENGINE
LUBRICATION

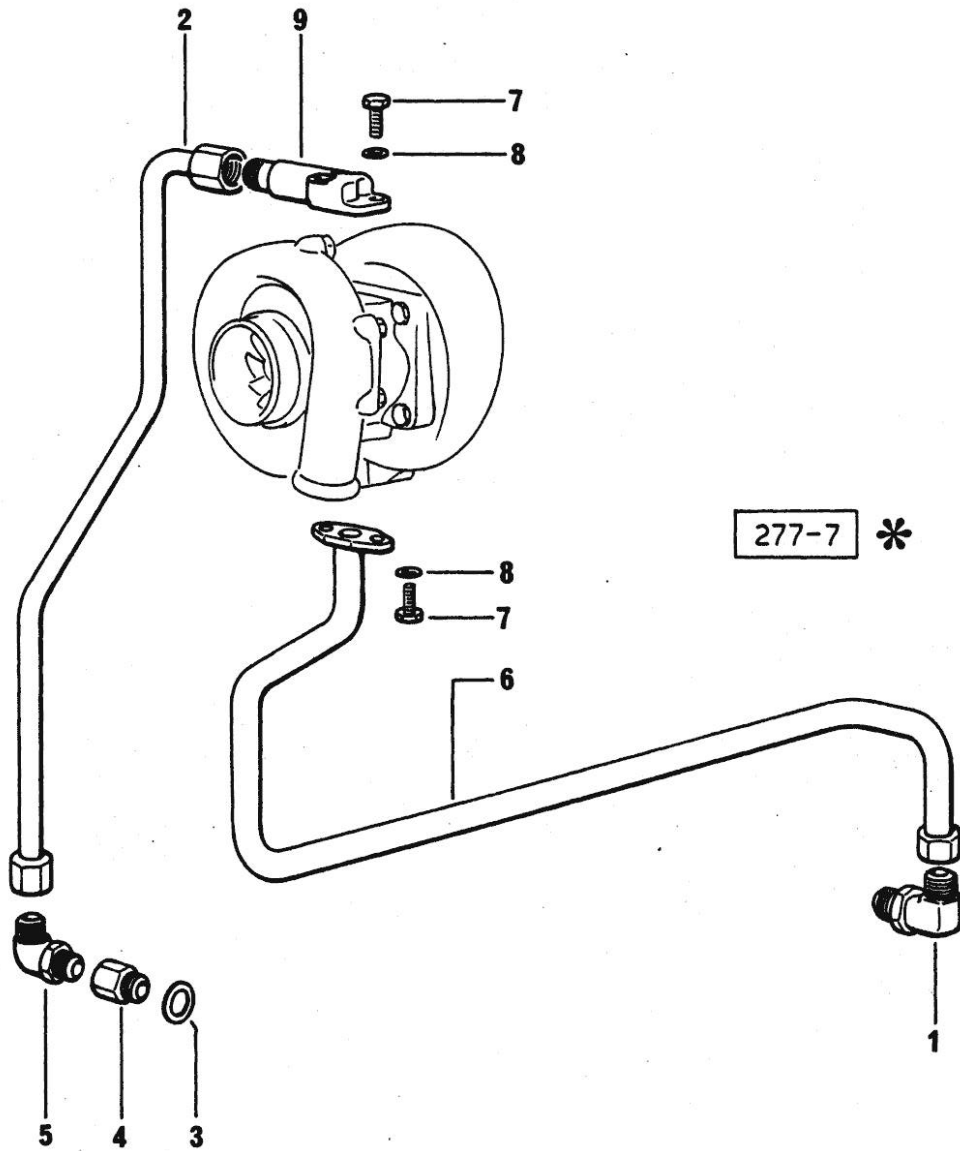

Fig.	P/n	QTY	Name
------	-----	-----	------

Notes:
 [H 6170 T]

1	2.3339.369.2	1	pipe fitting
2	0.064.1553.2/10	1	tube
3	2.1560.008.0	1	gasket 12.2 x 18
4	2.3339.368.1	1	pipe fitting
5	2.3264.018.1	1	pipe fitting
6	0.064.1552.2/10	1	tube
7	2.0112.207.2	3	screw m 8 p 1.25 x 20
7	2.0112.213.2	1	screw m 8 p.1.25 x 35
8	2.1474.009.1	4	spring washer 8
9	0.062.1550.0	1	flange

Section: ENGINE
LUBRICATION

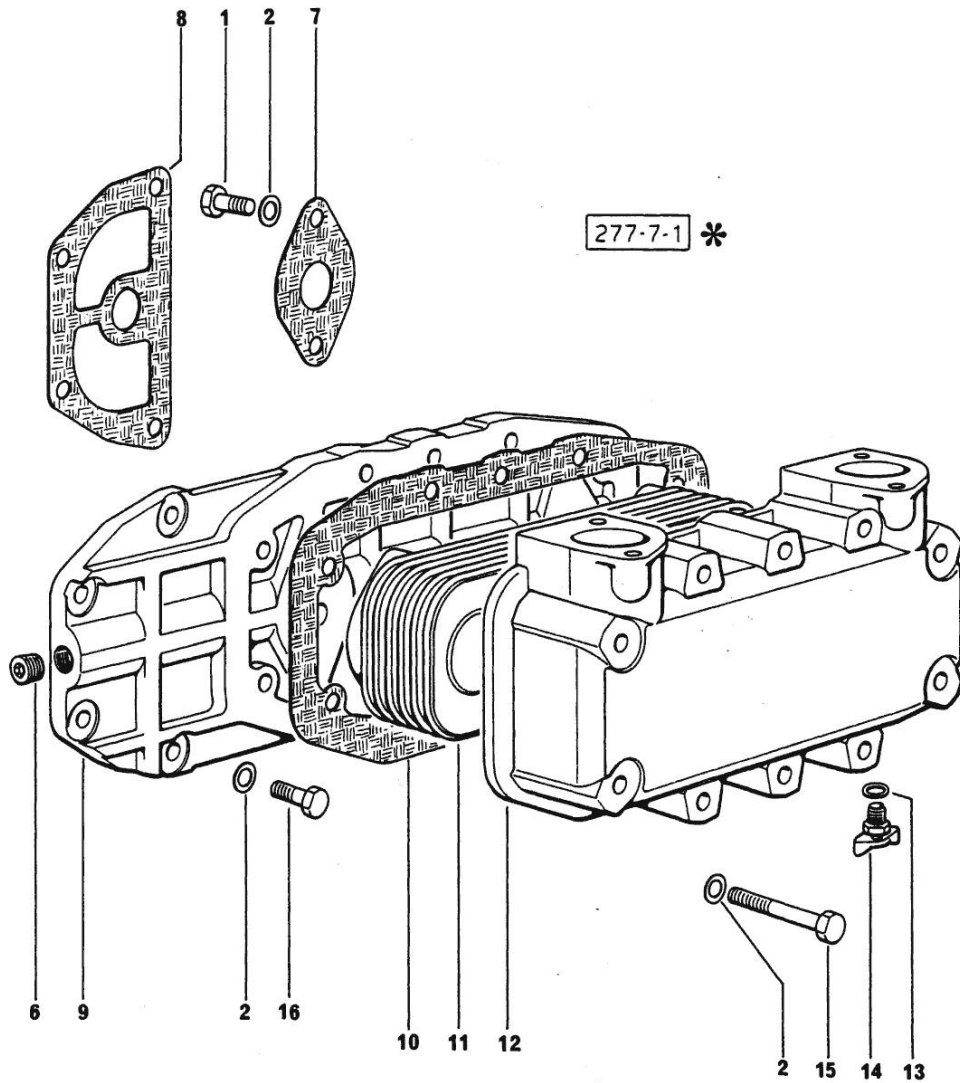

Fig.	P/n	QTY	Name
------	-----	-----	------

Notes:
 [H 6170 T]

1	2.0112.209.2	4	screw m 8 p 1.25 x 25
2	2.1474.009.1	16	spring washer 8
6	2.3131.003.4	1	plug m 16 p.1.5
7	0.061.1541.0	2	gasket
8	0.061.1553.0	2	gasket
9	0.064.1550.0/20	1	flange
10	0.064.1558.0/10	1	gasket
11	0.061.1540.2	1	heat exchanger
12	0.064.1551.0/10	1	body
13	2.1560.009.0	1	gasket 14.2x18
14	0.049.1152.0	1	cock
15	2.0112.229.2	8	screw m 8 p.1.25 x 100
16	2.0112.211.2	3	screw m 8 p.1.25 x 30

<https://www.ebooklibonline.com>

Hello dear friend!

Thank you very much for reading.

Enter the link into your browser.

The full manual is available for immediate download.

<https://www.ebooklibonline.com>