



# 347 BALERS



JOHN DEERE

## OPERATORS MANUAL

### 347 BALERS

OME70283 I4 English

JOHN DEERE OTTUMWA WORKS  
OME70283 I4

LITHO IN THE U.S.A.  
ENGLISH

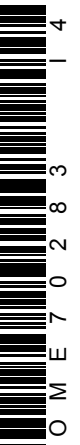

## INTRODUCTION

**⚠** This safety alert symbol identifies important safety messages in this manual. When you see this symbol, be alert to the possibility of personal injury and carefully read the message that follows.

Measurements are shown with their respective Metric equivalents throughout this operator's manual. These equivalents are the SI (International System) Units of Measure.

"Right-hand" and "left-hand" sides are determined by facing in the direction the baler will travel when in use.

Your warranty appears on your copy of the purchase order copy which you should have received from your dealer.

Record your baler model and serial numbers on page 108.

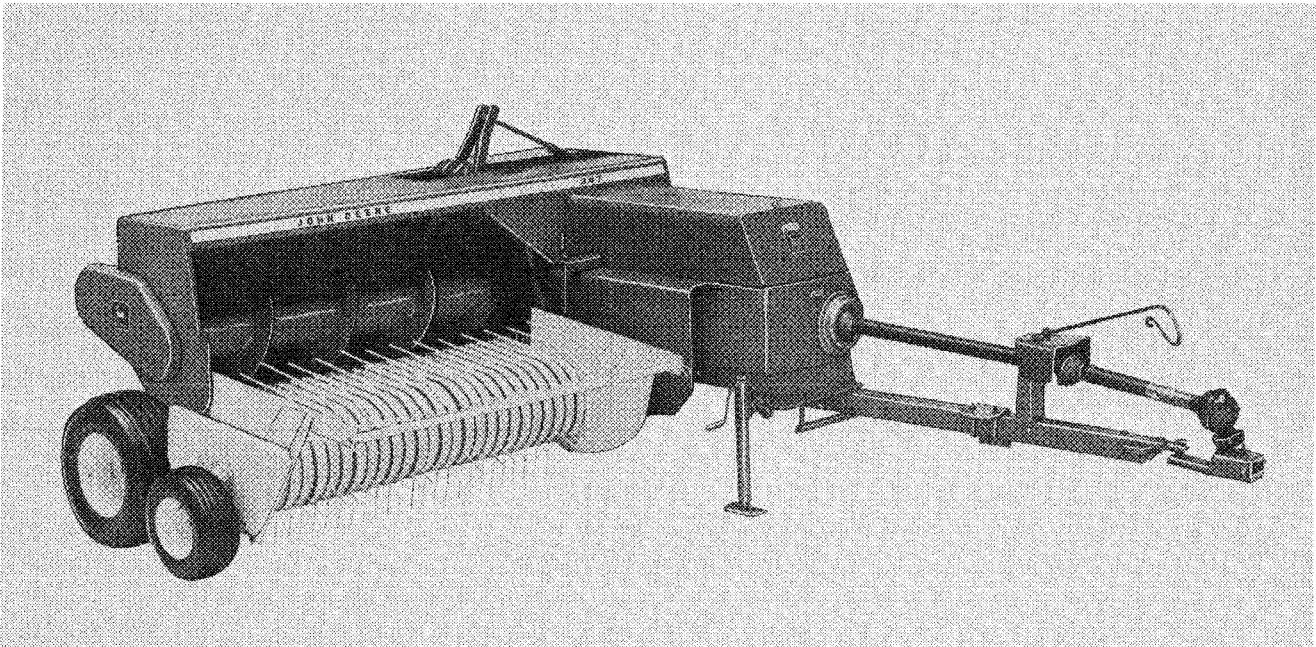

*John Deere 347 Baler*

E22703

# Predelivery

## PREDELIVERY CHECK LIST

After the baler has been completely assembled, inspect it to be sure it is in good running condition before delivering it to the customer. The following check list is a reminder of points to inspect. Check off each item as it is found satisfactory or after proper adjustment is made.

- Baler has been assembled properly. (See Assembly)
- Shipping plug has been replaced with relief valve on gear case. (See Assembly)
- Baler has been lubricated. (See Lubrication)
- All moving parts are working freely.
- Plungerhead and stationary knife clearance has been checked. (See Service)
- Check measuring arm adjustment. (See Service)

\_\_\_\_\_  
(Date set up)

## OWNER REGISTER

Name .....  
RR# .....  
County ..... State .....  
Model No. ....  
Serial No. ....  
Operator's Manual No. OM-E70283 .....  
Date Sold .....

- PTO slip clutch has been checked for specified slippage. (See Service)
- Tire pressures have been checked. (See Specifications)
- Pickup spring tension is properly adjusted. (See Service)
- Drive gears have been lubricated before run-in. (See Preparing the Baler)
- Baler has been run in one hour. (See Preparing the Baler)

\_\_\_\_\_  
(Signature)

AA7; E01;347PD A 210781

## DELIVERY CHECK LIST

The following check list is a reminder of very important information which should be conveyed directly to the customer at the time the baler is delivered. Check off each item as it is fully explained.

- Advise the customer that the life expectancy of this, like any other machine, is dependent on regular lubrication as described in operator's manual.
- Give the operator's manual to the customer and explain all operating adjustments and lubrication fully.
- Explain proper ASAE standard dimensions for PTO hookup.
- Advise customer of safety precautions that must be observed while using this baler.

\_\_\_\_\_  
(Date delivered)

- Tell customer the right-hand wheel of the tractor should be moved all the way in on tractors having adjustable-tread width.
- When the baler is transported on a road or highway at night or during the day, accessory lights and devices should be used for adequate warning to operators of other vehicles. Various safety lights and devices are available from your John Deere dealer. In this regard, tell customers to check local governmental regulations. Among these is the SMV (slow-moving vehicle) emblem which can be attached vertically to the rear of the auger housing.
- Advise the customer of the optional attachments that are available for special crop and operating conditions.

\_\_\_\_\_  
(Signature)

AA7; E01;347U B 250684

E07;IFC 140784

**<https://www.ebooklibonline.com>**

Hello dear friend!

Thank you very much for reading.

Enter the link into your browser.

The full manual is available for immediate download.

**<https://www.ebooklibonline.com>**

### **AFTER-SALE CHECK LIST**

It is suggested that the following items be checked sometime during the first season's operation.

- |  |  |
|--|--|
| <input type="checkbox"/> Go over entire machine for loose or missing bolts.  | <input type="checkbox"/> Check for broken or damaged parts.  |
| <input type="checkbox"/> Check for correct needle, feeder, and plunger-head timing as outlined in the operator's manual. | <input type="checkbox"/> If possible, run the baler to see if it is functioning properly.  |
| <input type="checkbox"/> Check the plungerhead for proper adjustment.  | <input type="checkbox"/> A good quality twine or wire is being used and is threaded properly.  |
| <input type="checkbox"/> Inspect the plungerhead and stationary knives to be sure they are sharp and properly adjusted.  | <input type="checkbox"/> Check knotter adjustments. If possible, inspect ties on a few bales.  |
| <input type="checkbox"/> All chains and belts are properly tightened.  | <input type="checkbox"/> Review the entire operator's manual with the customer and stress the importance of proper and regular lubrication and safety precautions. |
| <input type="checkbox"/> All safety shields are in place.  |  |

---

(Date checked)

---

(Signature)

AA7; E01;347U C 250684

# Contents

	Page
Safety . . . . .	2
Preparing the Tractor . . . . .	6
Preparing the Baler . . . . .	8
Attaching and Detaching . . . . .	16
Transporting . . . . .	19
Operating the Baler . . . . .	20
Attachments . . . . .	29
Lubrication . . . . .	33
Troubleshooting . . . . .	41
Service . . . . .	54
Storage . . . . .	85
Crime Prevention Tips. . . . .	85A
Assembly . . . . .	86
Specifications. . . . .	105
Index. . . . .	109

# Safety

## BEFORE OPERATING

1. Read operator's manual, machine decals and SAFETY section of this manual.
2. Remove foreign objects from machine.
3. All shields must be in place and secure.
4. Become familiar with all controls.

AA7; E01;347SA A 210781

## PROTECT AGAINST NOISE

Prolonged exposure to loud noise can cause impairment or loss of hearing.

Wear a suitable hearing protective device such as earmuffs (A) or earplugs (B) to protect against objectionable or uncomfortable loud noises.

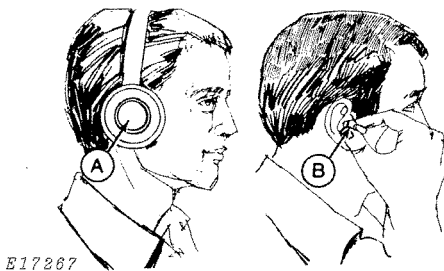

AA7;E17267 E01;347SA B 210781

## PRACTICE SAFE MAINTENANCE

Before servicing, adjusting, removing material, or hitching wagon to baler, always:

1. Disengage all power.
2. Shut off engine.
3. THEN WAIT until all moving parts have stopped moving.

AA7; E01;347SA C 210781

## AVOID HIGH-PRESSURE FLUIDS

Escaping fluid under pressure can penetrate the skin causing serious injury. Relieve pressure before disconnecting hydraulic or other lines. Tighten all connections before applying pressure. Keep hands and body away from pinholes and nozzles which eject fluids under high pressure. Use a piece of cardboard or paper to search for leaks. Do not use your hand.

If ANY fluid is injected into the skin, it must be surgically removed within a few hours by a doctor familiar with this type injury or gangrene may result.

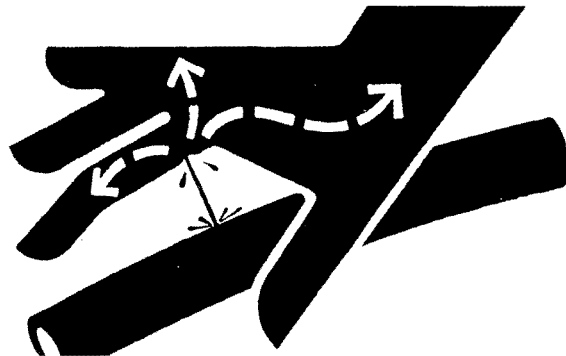

AA7;X9811 E01;347SA I 100683

### SERVICE TIRES SAFELY

Failure to follow proper procedures when mounting a tire on a wheel or rim can produce an explosion which may result in serious injury or death. Do not attempt to mount a tire unless you have the proper equipment and experience to perform the job. Have it done by your John Deere dealer or a qualified tire repair service.

When sealing tire beads on rims, never exceed 35 psi (240 kPa) (2.4 bar) or maximum inflation pressures specified by tire manufacturers for mounting tires. Inflation beyond this maximum pressure may break the bead, or even the rim, with dangerous explosive force. If both beads are not seated when the maximum recommended pressure is reached, deflate, reposition tire, relubricate bead, and reinflate.

Detailed agricultural tire mounting instructions, including necessary safety precautions, are contained in John Deere Fundamentals of Service (FOS) Manual 55, Tires and Tracks, available through your John Deere dealer. Such information is also available from the Rubber Manufacturers Association and from tire manufacturers.

- A—Use a safety cage if available.
- B—Do not stand over tire. Use a clip-on chuck and extension hose.

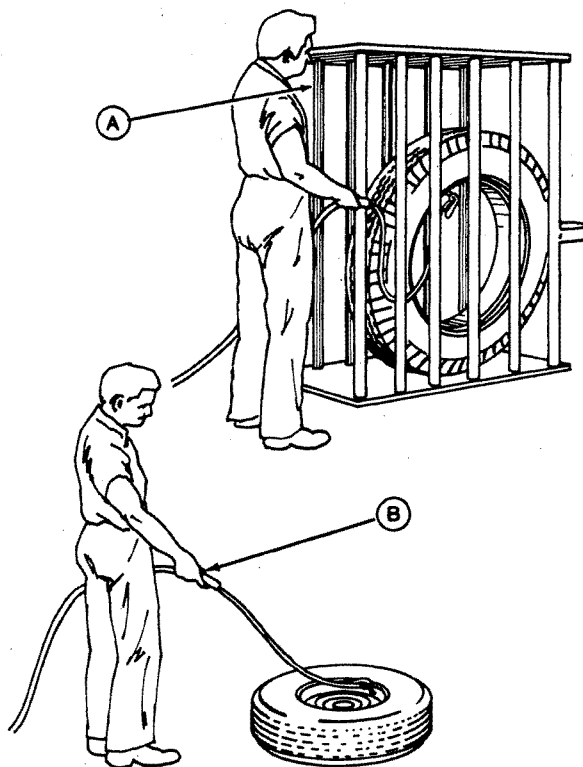

AA7;TS0123 E01;347SA D 061083

### TRANSPORT SAFELY

Never tow baler faster than 20 mph (32 km/h).

When transporting the baler on a road or highway at night or during the day, use accessory lights and devices for adequate warning to operators of other vehicles. In this regard, check local governmental regulations. Various safety devices are available from your John Deere dealer.

Be sure SMV emblem and warning lights are clean and visible.

When transporting baler, raise bale chute and secure to reduce chain stretch or wear on friction washers. Also raise pickup to highest position to prevent pickup damage.

AA7; E01;347SA E 210781

E07;03 140683

## OBSERVE SAFETY SIGNS AND MESSAGES



**CAUTION:** This message is used for general reminders of good safety practices or to direct attention to unsafe practices. The message will appear in your operator's manual and/or the sign will appear on the machine with the color combination of yellow and black.

**WARNING:** This message denotes a specific potential hazard. The sign will be displayed on the machine in areas of potential hazard. The sign will have the color combination of yellow and black.

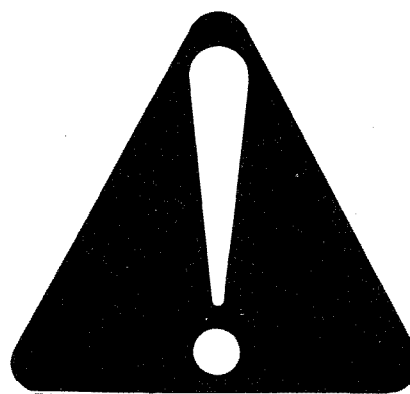

T27999N

**DANGER:** This message denotes the most serious specific potential hazard. The sign will be displayed on the machine in areas of potential hazard. The sign will have the color combination of red and white.

AA7;T27999 N E01;3475A F 210781

## OBSERVE "IMPORTANT" MESSAGES

Messages labeled "important" will appear in your operator's manual and/or on the machine to provide specific instructions for performing adjustments, services, etc. If these instructions are not followed it could result in damage to the machine.

AA7; E01;3475A G 210781

## DO NOT MODIFY MACHINE

Unauthorized modifications to the machine may impair the function and/or safety and affect machine life.

AA7; E01;3475A H 210781

## OPERATE SAFELY

Never allow riders on the baler.

Keep all shields in place when operating baler.

Wear relatively tight and belted clothing to prevent catching on machine parts.

DO NOT trip knotter by hand with machine running. Stand clear of needle frame.

Do not try to remove or pull twine or wire from bale case or knotter when baler is running.

Do not attempt to pull hay from pickup when baler is running.

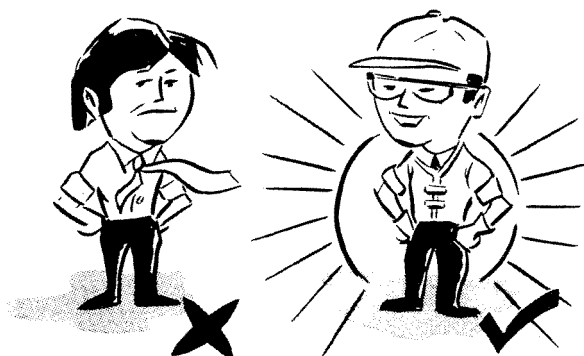

AA7;E19363 E01;3475A J 210781

## DRIVING ON PUBLIC ROADS

A safety chain (A) will help control drawn equipment should it accidentally separate from the drawbar while transporting. Using the appropriate adapter parts, attach the chain to the tractor drawbar support or other specified anchor location. Provide only enough slack in the chain to permit turning. See your John Deere dealer for a chain with a strength rating greater than the gross weight of the towed load.

Never tow baler faster than 20 mph (32 km/h).

When transporting the equipment on a road or highway at night or during the day, use accessory lights and devices for adequate warning to operators of other vehicles. In this regard, check local governmental regulations. Various safety devices are available from your John Deere dealer.

Be sure SMV emblem and warning lights are clean and visible.

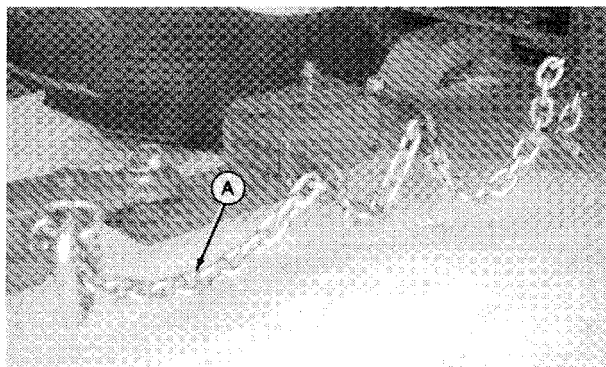

AA7;E23897 E01;;347C K 250684

# Preparing the Tractor

## ADJUSTING THE DRAWBAR

**IMPORTANT:** Before attaching baler to tractor, be sure to adjust tractor drawbar so it measures 14-in. (356 mm) from the end of power take-off shaft to hitch pin hole in the drawbar (A). Replace all shields removed.

Vertically align drawbar hitch pin hole with centerline of tractor power take-off shaft. Set drawbar to the following dimensions.

- A—14-in. (356 mm)
- B—6-12 in. (152-305 mm)
- C—13-20 in. (330-508 mm) to ground
- D—Equal Angle Hitch

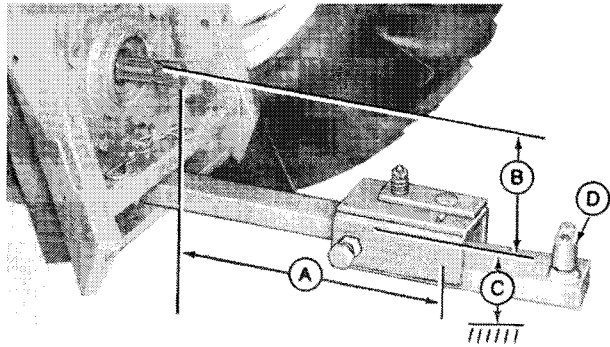

AA7;E19279 E01;;347V A 250684

## ATTACHING HITCH TO DRAWBAR

To attach equal angle hitch (A), slide hitch onto tractor drawbar. Place shims (B) between drawbar and hitch for a tight fit. Store extra shims under locking strap (C). Secure with hitch pin and spring pin (D).

Tighten adjusting bolts (E) on both sides of equal angle hitch. Tighten jam nuts against hitch.

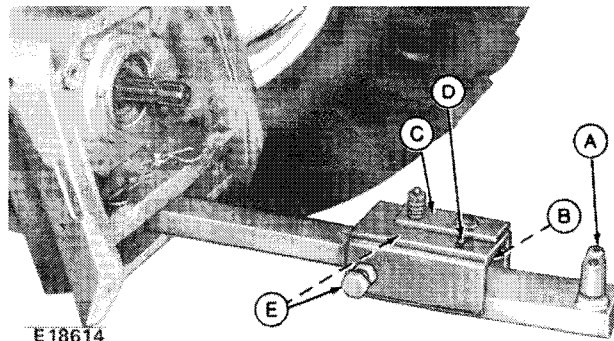

- A—Equal Angle Hitch
- B—Shims
- C—Locking Strap

- D—Spring Pin
- E—Adjusting Bolts

AA7;E18614 E01;347PT B 210781

E07;06 140784

### **CHECKING BALLAST, WHEEL SPACING, AND TIRE INFLATION**

Provide sufficient weight to stabilize tractor when operating on hilly land or other adverse conditions. See your tractor operator's manual.

To insure proper stability, adjust ballast, wheel spacing and tire inflation according to tractor operator's manual.

AA7; E01;347FT C 210781

### **TRACTOR PTO SPEED**



**CAUTION:** Under no circumstances should a baler equipped for 540 rpm PTO drive be operated with a tractor equipped with 1000 rpm PTO.

E01;;347V D 250684

# Preparing the Baler

## BREAKING IN THE BALER

After baler has been attached to the tractor, inspect it to be sure all bolts are tight and all chains have proper tension.

*NOTE: On twine balers, grease has been applied at the factory to knotter area. Some misses in tying may occur on the first few bales due to this grease. Do not attempt to make adjustment until all knotter parts have had time to become thoroughly polished by the twine.*

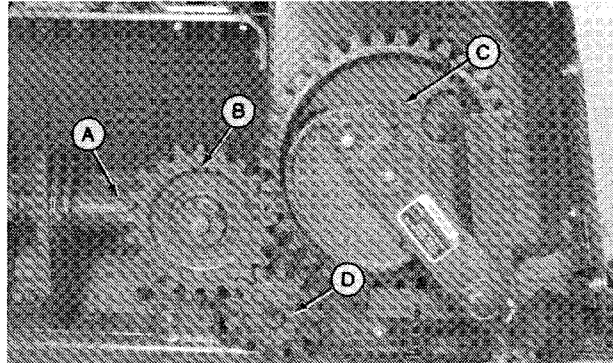

Drive gears must be lubricated during “break-in” period to insure that any casting irregularities will become worn smooth. Apply a liberal coating of multipurpose grease to each tooth on all gears shown. This must be done before the 1-hour empty running “break-in” procedure described below.

Give new baler an empty running “break-in” period of at least 1 hour to allow parts to work in gradually. After a short run at slow idling speed, stop machine and inspect for loose bolts, heating bearings, binding parts, chain tension, etc. Run baler at slow idling speed for 30 minutes, and increase to full speed for the rest of the period. Inspect baler frequently during “break-in” period. Never trip baler at full RPM without twine in twine disk holder.

- A—Main Drive Gear
- B—Cluster Gear
- C—Clutch Ring Gear
- D—Auger Drive Gear

AA7;E24763 E01;;3471 A 250684

## OPERATING JACK STAND

When operating or transporting baler, secure jack stand (A) in storage location (B) as shown.

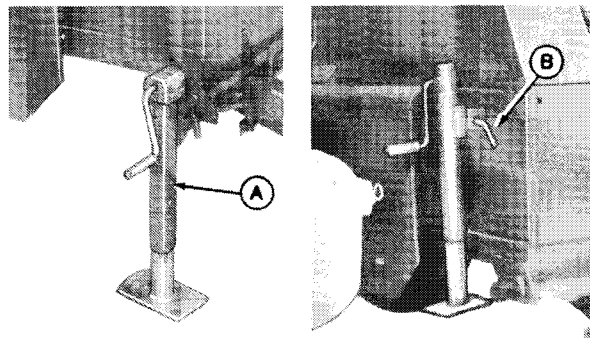

AA7;E19281, E19352 E01;347PM B 210791

### POSITIONING TONGUE FOR OPERATION

To change from transport to operating position, remove pin which secures tongue in transport position.

Put a block in front of right-hand wheel and shift tongue to left.

Secure tongue with locating pin.

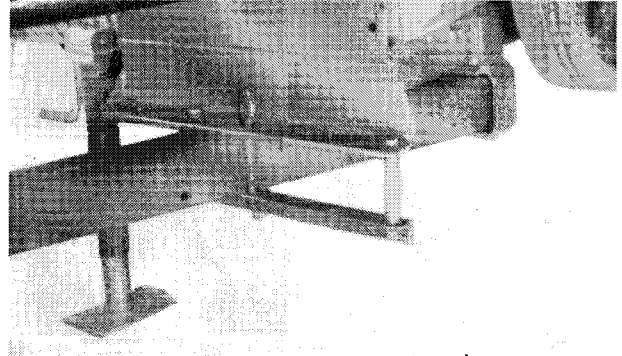

AA7;E19435 E01;347PM C 210781

### ATTACHING HYDRAULIC TONGUE POSITIONING CYLINDER

**IMPORTANT:** A double-acting 8-in. (230 mm) hydraulic cylinder with a minimum 3-in. (76 mm) bore must be used when positioning tongue.

1. Install hydraulic cylinder (A) as shown.
2. Attach hose clamps (B) using a 3/8 x 1-in. cap screw and lock nut.

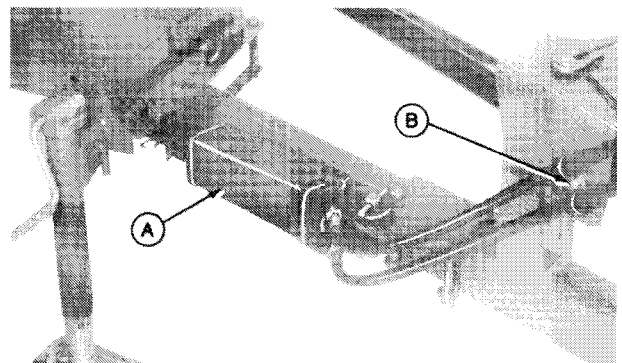

AA7;E19282 E01;347PM D 210781

3. Set hoses in support and secure with plastic tie (C) as shown. Attach to appropriate couplers, (available from your John Deere dealer according to tractor model), on left-hand side of tractor. Leave enough slack in hoses to allow for movement of baler.

**IMPORTANT:** Excessive hydraulic operating speed may cause damage. Use a slow (turtle) speed when changing tongue position.

**IMPORTANT:** Disengage PTO before attempting to position tongue hydraulically to avoid drive train damage.

4. After hookup is complete, slowly operate hydraulic cylinder several times. Hold tractor remote hydraulic control lever in operating position for a few seconds. This will clear air in the hydraulic system, which might cause improper operation of the hydraulic cylinder.

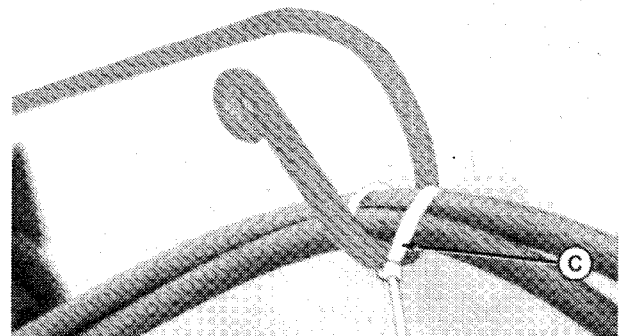

AA7;E22704 E01;347PM E 280783

## SELECTING CORRECT TWINE AND WIRE

For trouble-free baling operation, select twine or wire which meets ASAE standards.

Select twine of good tensile strength and uniformity in size for proper knotter operation. This will also help prevent twine from breaking during handling and transporting of bales.

AA7; E01;347PM F 220781

## LOADING TWINE BOX

1. Place two balls of good quality twine in each compartment of the twine box. Be sure twine is pulled from end of ball marked "top".
2. Join two balls in each section by tying outside end of first ball to inside end of second ball. In joining twine, use a modified square knot with sisal twine and a sheetbend knot with plastic twine.
3. Trim loose ends of twine as close to knot as possible.
4. Thread twine from center of each ball through its respective guide (A) box lid; then thread both ends of twine through tension plate (B) on side of twine box.
5. Always have a new ball of twine in the left-hand compartment.

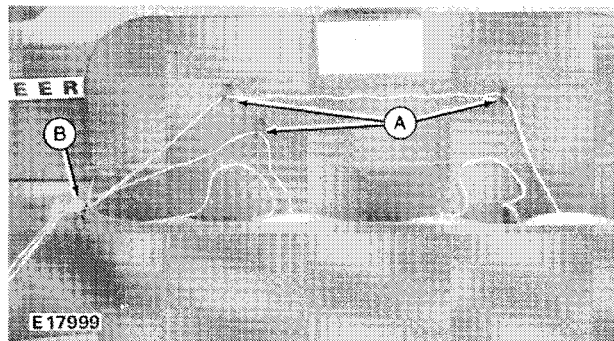

AA7;E17999 E01;347PM G 220781

## USING MODIFIED SQUARE KNOT— SISAL TWINE

**IMPORTANT:** Knot must be small enough to pass through the guides and needle eyes.

Moisten twine ends and tie twine balls together with a square or modified square knot as shown.

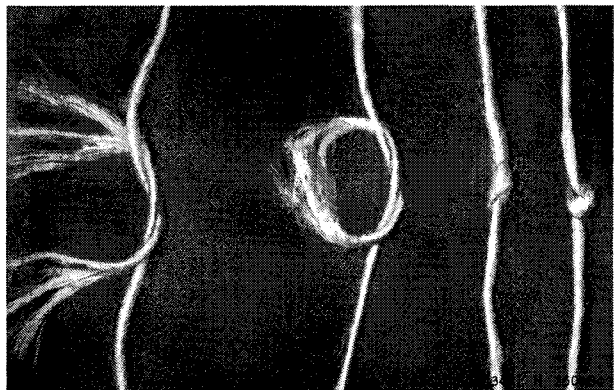

E07;10 140784



**Suggest:**

**For more complete manuals. Please go to the home page.**

**<https://www.ebooklibonline.com>**

**If the above button click is invalid. Please download this document first, and then click the above link to download the complete manual.**

**Thank you so much for reading**

### USING SHEET BEND KNOT—PLASTIC TWINE

**IMPORTANT:** Knot must be small enough to pass through guides and needle eyes.

Tie plastic twine balls together with a sheet bend knot as shown.

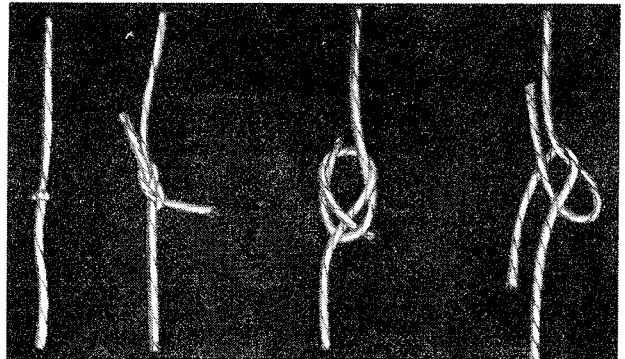

AA7;E11344 Y E01;347PM I 220781

### THREADING NEEDLES—TWINE BALER



**CAUTION:** Disengage PTO and shut off tractor engine before threading needles.

**IMPORTANT:** This threading procedure is separated by right and left side **ONLY** for illustration purposes.

*NOTE:* A detailed threading diagram is located underneath twine box lid.

AA7; E01;347PM J 220781

### THREADING RIGHT-HAND NEEDLE

**IMPORTANT:** Do not cross twine during theading operation.

1. With needles in "home" position, thread twine from inside ball through lower guide and through **FRONT** of tension plate.

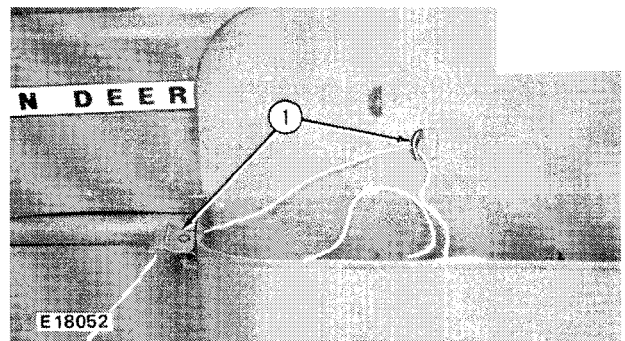

AA7;E18052 E01;347PM K 220781

## Preparing the Baler

2. Thread through eye on needle frame.

3. Thread twine UNDER needle guard, through eye, beneath right-hand needle and through right-hand needle. Thread twine OVER guide on end of needle.

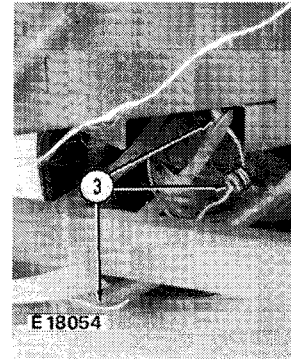
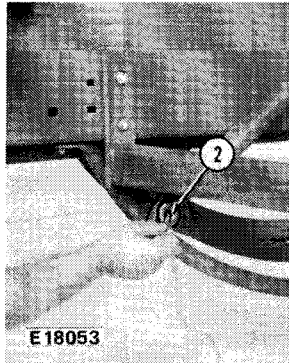

AA7/E18053, E18054 E01:347PM L 220781

4. Secure twine to measuring wheel as shown.

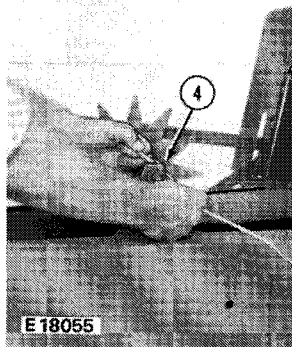

AA7/E18055 E01:347PM M 220781

## THREADING LEFT-HAND NEEDLE

1. Thread twine from outside ball and through REAR of tension plate.

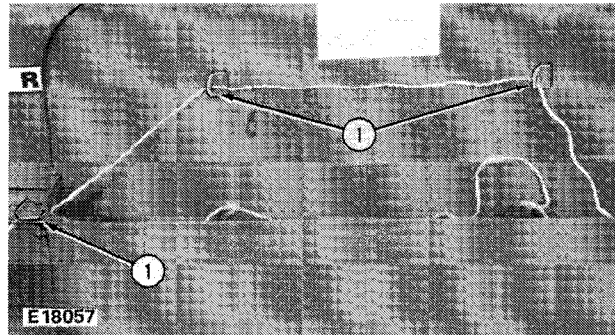

AA7/E18057 E01:347PM N 220781

2. Thread through eye on needle frame.

3. Throw twine under bale case as shown.

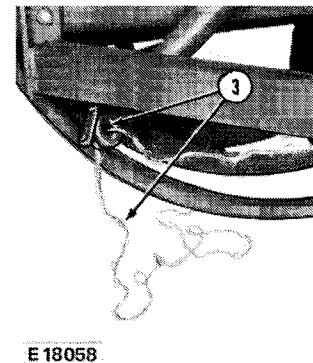
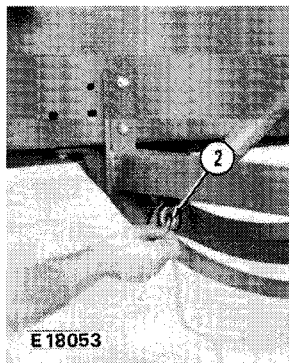

AA7/E18053, E18058 E01:347PM O 220781

**<https://www.ebooklibonline.com>**

Hello dear friend!

Thank you very much for reading.

Enter the link into your browser.

The full manual is available for immediate download.

**<https://www.ebooklibonline.com>**