

Page Number	Page Title	Page Reference
01-000-TOC	ENGINE, FUEL AND EXHAUST SYSTEM	01-000-TOC
02-000-TOC	AXLES	02-000-TOC
03-000-TOC	STEERING SYSTEM	03-000-TOC
04-000-TOC	DRIVE TRAIN SYSTEM	04-000-TOC
05-000-TOC	COMPRESSED AIR SYSTEM	05-000-TOC
06-000-TOC	HYDRAULIC SYSTEM	06-000-TOC
07-000-TOC	ELECTRICAL SYSTEM	07-000-TOC
08-000-TOC	CAB	08-000-TOC
09-000-TOC	AIR CONDITIONING AND HEATING SYSTEM	09-000-TOC
10-000-TOC	CHASSIS	10-000-TOC
11-000-TOC	WHEELS	11-000-TOC
12-000-TOC	IMPLEMENT LIFT SYSTEM FRONT	12-000-TOC
13-000-TOC	IMPLEMENT LIFT SYSTEM REAR	13-000-TOC
14-000-TOC	ACCESSORIES	14-000-TOC

FAVORIT 920 (920/00401-01000 & 03001-06000)
41076

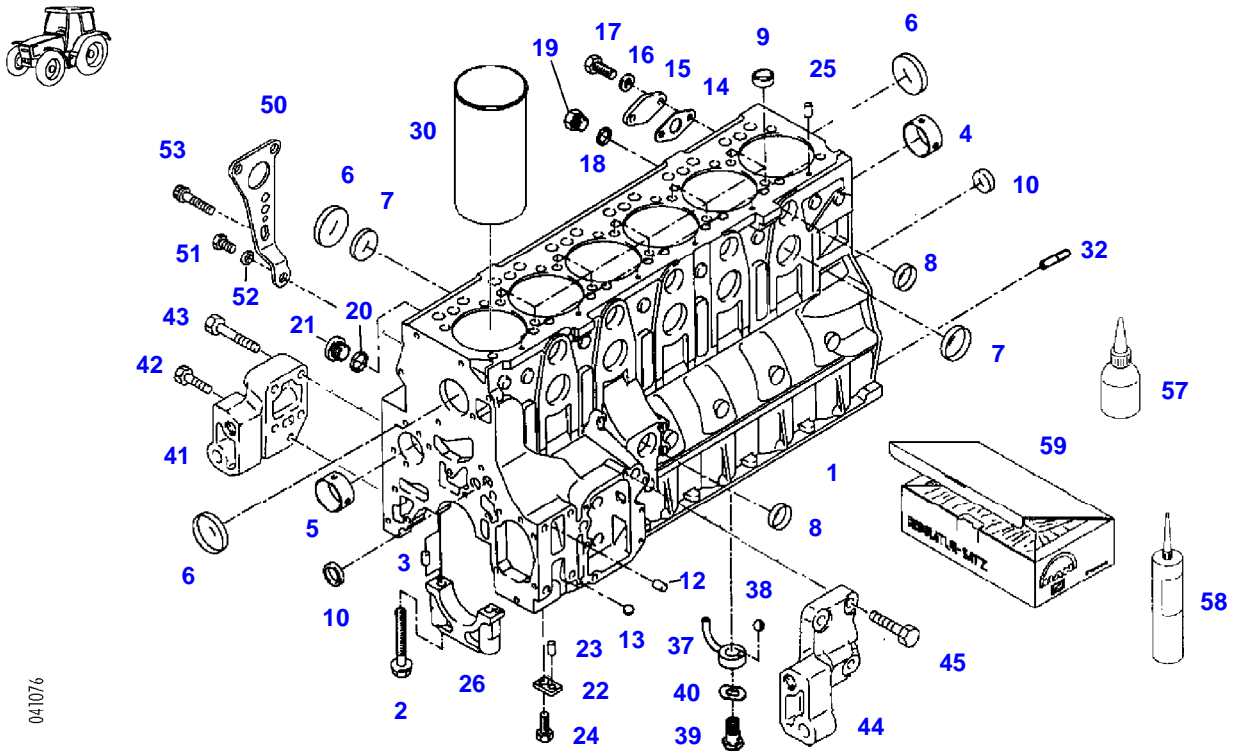

041076

Item	Part Number	Qty	Description Comments	Technical Specification
	72425112	1	SHORT ENGINE <-- 920/0401 --> 920/0700 <-- 920/3001 --> 920/4060 <-- 920/4062 --> 920/4140	
	72426537	1	SHORT ENGINE <-- 920/4061 --> 920/4061 <-- 920/4141	
1	72417053	1	CRANKCASE ><2-26	
2	72417054	14	HEX BOLT, WITH COLLAR M14X118	
3	72313719	2	CYLINDER PIN	
4	72417055	7	BEARING BUSHING	
	72417056	7	BEARING BUSHING OVERSIZE 0,03MM	
5	72417057	1	BEARING BUSHING <-- 920/0401 --> 920/0700 <-- 920/3001 --> 920/4060 <-- 920/4062 --> 920/4140	
	72426515	1	BEARING BUSHING <-- 920/4061 --> 920/4061 <-- 920/4141	
	72417058	1	BEARING BUSHING UNDERSIZE 0.03MM <-- 920/0401 --> 920/0700 <-- 920/3001 --> 920/4060 <-- 920/4062 --> 920/4140	
	72426460	1	BEARING BUSHING UNDERSIZE 0.03MM <-- 920/4061 --> 920/4061 <-- 920/4141	
6	72417059	8	COVER 62,15MM	
7	72311422	11	COVER 50,20MM	
8	72311424	6	COVER 40,20MM	
9	72311426	10	COVER	
10	72311432	2	COVER	
12	72314696	1	SEALING PLUG	
13	72310168	1	BALL	
14	72312268	1	SEAL	
15	72312125	1	FLANGE	
16	72311788	2	DISC	DIN 125-8,4-ST.A3L
17	72315650	2	HEXAGONAL HEAD BOLT	DIN 933 M8 X 20-8.8A3L
18	72422299	1	SEALING WASHER	
19	72315799	1	PLUG	DIN 7604 AM14X1,5-A3L
20	72417074	3	SEALING WASHER	
21	72315445	3	PLUG	DIN 908 M30X1,5-ST
22	72417060	1	LOCK PLATE ><23	
23	72420231	1	CYLINDER PIN	DIN 7-5M6X10-ST50-2K
24	72315705	1	HEXAGONAL HEAD BOLT	DIN 933 M12X20-8.8A3L
25	72420232	6	CYLINDER PIN	DIN 7-6M6X10-ST50-2K
26			NOT AVAILABLE IN SINGLE PARTS	
30	72313100	6	SLEEVE BUSHING	
	72431672	6	CYLINDER LINER COLLAR OVERSIZE 0.20MM	
32	72313721	2	CENTERING PIN	
37	72313230	6	OIL SPLASH NOZZLE ><38	
38			NOT AVAILABLE IN SINGLE PARTS	
39	72317037	6	OIL PRESSURE VALVE	
40	72317123	6	SPRING WASHER	DIN 137 B12-ZNPHR

<https://www.ebooklibonline.com>

Hello dear friend!

Thank you very much for reading.

Enter the link into your browser.

The full manual is available for immediate download.

<https://www.ebooklibonline.com>

CRANKCASE

Item	Part Number	Qty	Description Comments	Technical Specification
41	72428719	1	ENGINE SUPPORT	
42	72315688	1	HEXAGONAL HEAD BOLT	M10 X 35 CL10.9
43	72315559	4	HEXAGONAL HEAD BOLT	DIN 931 M12X60 GWA-10.9
44	72428720	1	ENGINE SUPPORT	
45	72315713	4	HEXAGONAL HEAD BOLT	DIN 933 M12X40 GWA-10.9
50	72417061	1	SUSPENSION EYE	
51	72315721	1	HEXAGONAL HEAD BOLT	DIN 933 M14X25-8.8A3L
52	72311792	1	DISC	DIN125-15-ST
53			RE. EXHAUST MANIFOLD	
57	72313159	1	ADHESIVE	LOCTITE 648 50ML
58	72602309	1	SEALING COMPOUND	
59	72417062	1	SEAL KIT	

FAVORIT 920 (920/00401-01000 & 03001-06000)
40530

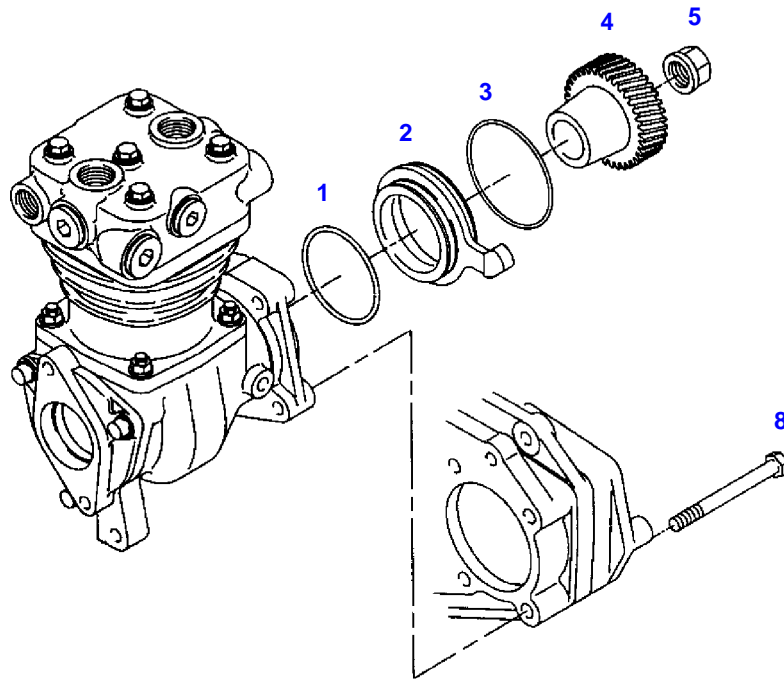

040530

Item	Part Number	Qty	Description Comments	Technical Specification
1	72313536	1	SEAL	
2	72312004	1	ECCENTRIC	
3	72313390	1	O-RING	
4	72417063	1	DRIVE GEAR	
5	72313333	1	WHEEL NUT	DIN74361-B20-8
8	72315551	4	HEXAGONAL HEAD BOLT	DIN 931 M10X100-8.8

FAVORIT 920 (920/00401-01000 & 03001-06000)
40531

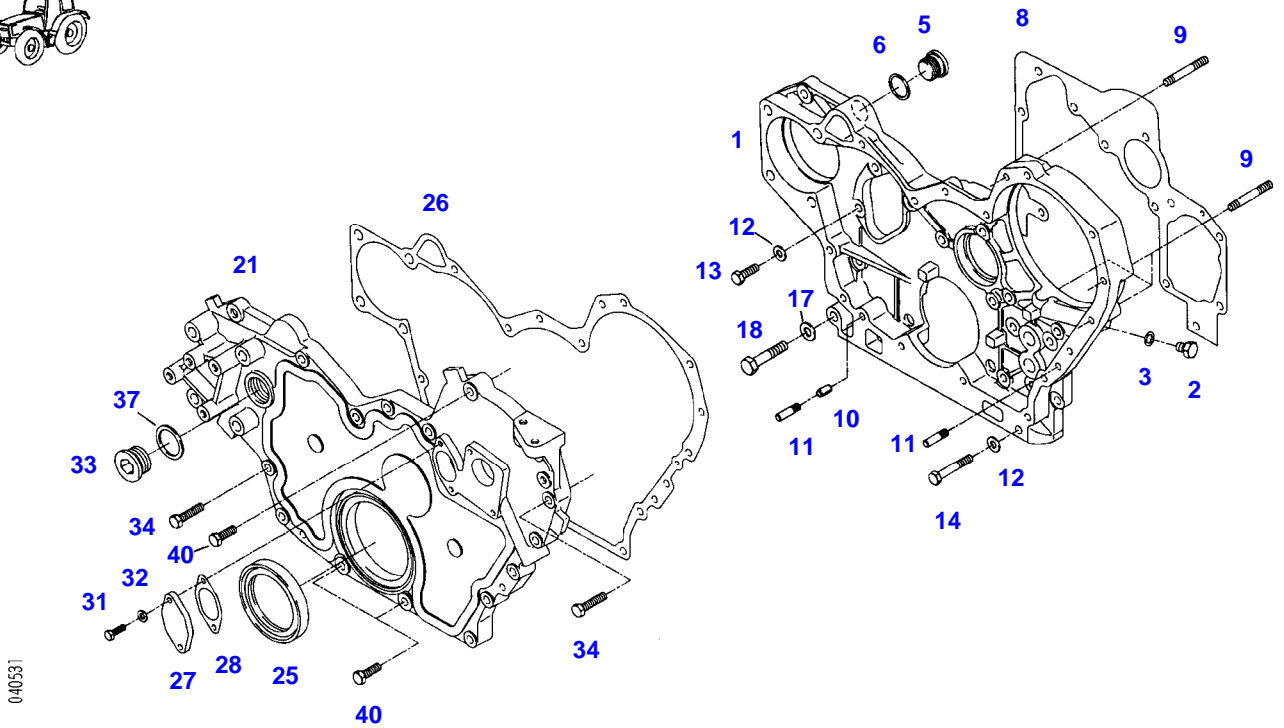

040531

Item	Part Number	Qty	Description Comments	Technical Specification
1	72312752	1	CONTROL HOUSING ><2-6	
2	72315627	1	HEXAGONAL HEAD BOLT	DIN 933 M6X8-8.8A3L
3	72417153	1	SEALING WASHER	
5	72315442	1	PLUG	DIN 908 M22X1,5-ST
6	72622285	1	SEALING WASHER	
8	72312259	1	SEAL	
9	72313712	4	STUD BOLT	
10	72313848	1	TENSIONING PIN	ISO8750-8X16-ST
11	72313720	2	CENTERING PIN	
12	72311788	12	DISC	DIN 125-8,4-ST.A3L
13	72315653	11	HEXAGONAL HEAD BOLT	DIN 933 M8 X 25-8.8A3L
14	72315529	1	HEXAGONAL HEAD BOLT	DIN 931 M8X50-8.8A3L
17	72311789	1	DISC	DIN 125-10,5-ST.A3L
18	72315544	1	HEXAGONAL HEAD BOLT	DIN 931 M10X50-8.8A3L
21	72428721	1	CRANKCASE END COVER	
25	72346310	1	SHAFT SEALING RINGS	
26	72312260	1	SEAL	
27	72417065	1	COVER	
28	72417066	1	SEAL	
31	72315625	2	HEXAGONAL HEAD BOLT	DIN 933 M6X16-8.8
32	72311787	2	DISC	DIN 125-6,4-ST.A3L
33	72315445	1	PLUG	DIN 908 M30X1,5-ST
34	72315663	12	HEXAGONAL HEAD BOLT	DIN 933 M8X40-8.8A3L
37	72417074	1	SEALING WASHER	
40	72315657	3	HEXAGONAL HEAD BOLT	DIN 933 M8 X 30-8.8A3L

FAVORIT 920 (920/00401-01000 & 03001-06000)
40532

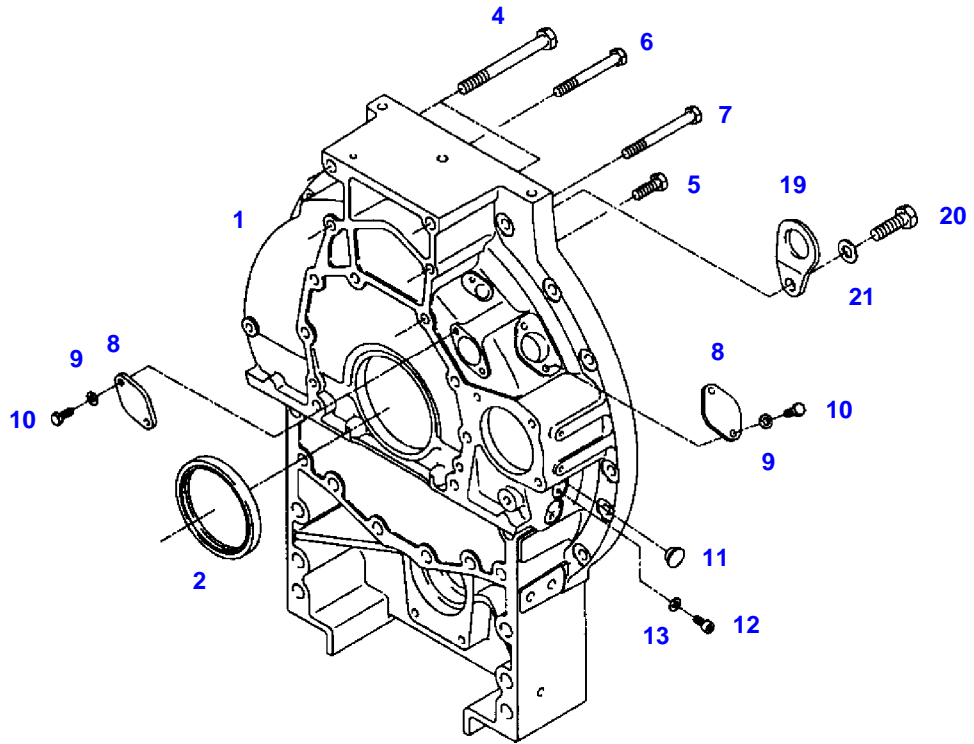

0440532

Item	Part Number	Qty	Description Comments	Technical Specification
1	72415318	1	FLYWHEEL HOUSING ><2	
2	72315031	1	SHAFT SEALING RINGS	
4	72315580	2	HEXAGONAL HEAD BOLT	DIN931-M14X140-10.9-ZNPHR3F
5	72315710	8	HEXAGONAL HEAD BOLT	DIN 933-M12X35 GWA-10.9
6	72315567	1	HEXAGONAL HEAD BOLT	DIN 931 M12X100 GWA-10.9
7	72315569	1	HEXAGONAL HEAD BOLT	DIN 931 M12X110 GWA-10.9
8	72312124	2	BLANK FLANGE	
9	72311788	4	DISC	DIN 125-8,4-ST.A3L
10	72315653	4	HEXAGONAL HEAD BOLT	DIN 933 M8 X 25-8.8A3L
11	72346444	2	LOCKING PLUG	
12	72374017	2	SOCKET HEAD BOLT	DIN 912 M8X12-8.8
13	72423360	2	GASKETS	
19	72423377	1	EYE	
20	72315721	1	HEXAGONAL HEAD BOLT	DIN 933 M14X25-8.8A3L
21	72311792	1	DISC	DIN125-15-ST

FAVORIT 920 (920/00401-01000 & 03001-06000)
40533

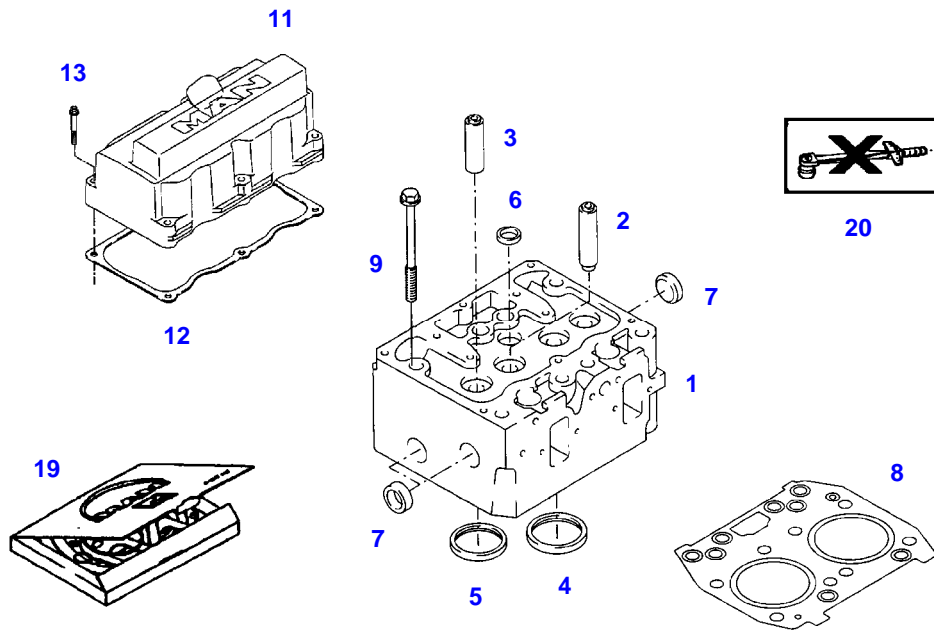

040533

Item	Part Number	Qty	Description Comments
1	72417067	3	CYLINDER HEAD ><2-7 <-- 920/0401 --> 920/0700 <-- 920/3001 --> 920/4060 <-- 920/4062 --> 920/4140
	72426461	3	CYLINDER HEAD ><2-7 <-- 920/4061 --> 920/4061 <-- 920/4141
2	72310651	6	VALVE GUIDE INTAKE 16,00MM
	72310652	6	VALVE GUIDE INTAKE 16,25MM
3	72310653	6	VALVE GUIDE OUTLET 16,00MM
	72310654	6	VALVE GUIDE OUTLET 16,25MM
4	72417068	6	VALVE SEAT RING INTAKE <-- 920/0401 --> 920/0700 <-- 920/3001 --> 920/4060 <-- 920/4062 --> 920/4140
	72426462	6	VALVE SEAT RING INTAKE <-- 920/4061 --> 920/4061 <-- 920/4141
	72492241	6	VALVE SEAT RING INTAKE REPAIR STEP <-- 920/0401 --> 920/0700 <-- 920/3001 --> 920/4060 <-- 920/4062 --> 920/4140
5	72315034	6	VALVE SEAT RING OUTLET 44,10MM
6	72311428	3	COVER
7	72311429	9	COVER
8	72312241	3	CYLINDER HEAD GASKET <>
	72426464	8	HEX BOLT, WITH COLLAR
9	72426464	24	HEX BOLT, WITH COLLAR MUST NOT BE RETIGHTENED SCREWS-TO BE USED ONCE ONLY
11	72417070	3	CYLINDER HEAD COVER
12	72317854	3	SEAL
13	72417071	17	TORX SCREW M6X35
	72416968	1	TORX SCREW M6X40
19	72312366	3	SEAL KIT <>
	72426464	8	HEX BOLT, WITH COLLAR
20	72423094	1	MARKING PLATE

FAVORIT 920 (920/00401-01000 & 03001-06000)
40534

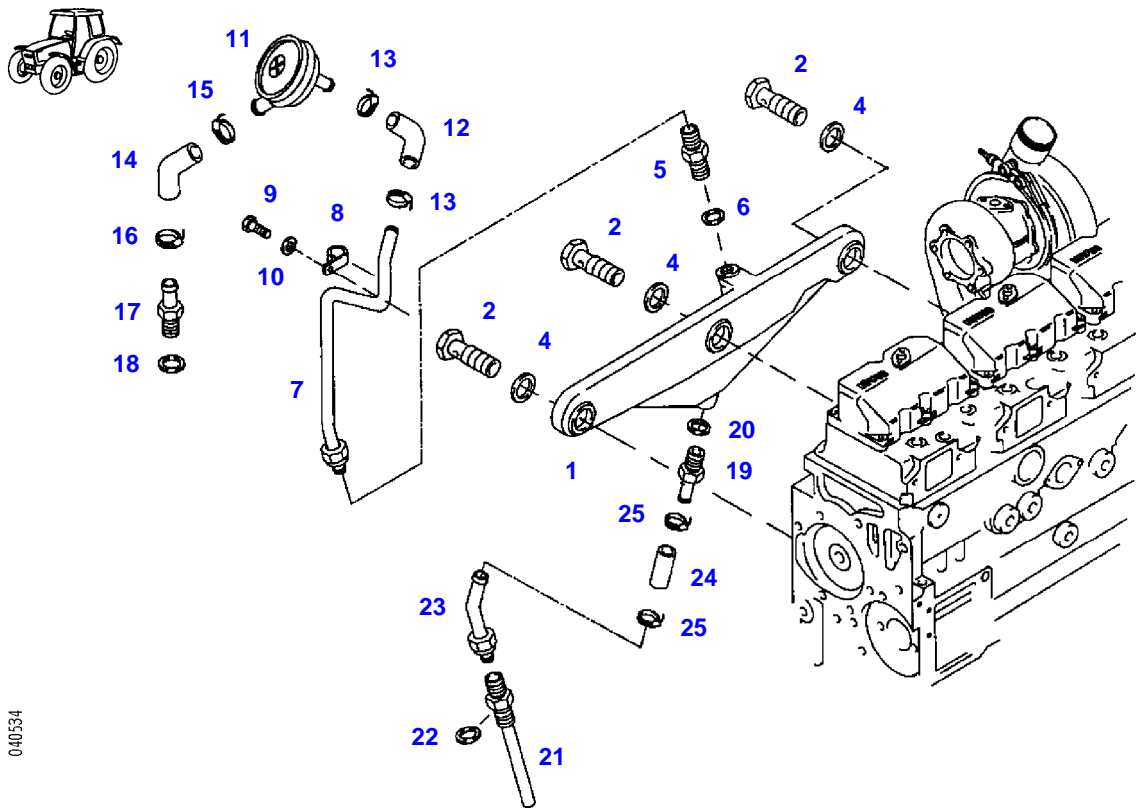

040534

Item	Part Number	Qty	Description Comments	Technical Specification
1	72417072	1	BREATHER MANIFOLD	
2	72417073	3	BANJO BOLT	
4	72417074	6	SEALING WASHER	
5	72417075	1	THREADED STUD	
6	72622285	1	SEALING WASHER	
7	72417076	1	BREATHER LINE ><8	
8	72346330	1	FASTENING COLLAR	
9	72315651	1	HEXAGONAL HEAD BOLT	DIN 933 M8X22-8.8A3L
10	72311788	1	DISC	DIN 125-8,4-ST.A3L
11	72317038	1	CONTROL VALVE	
12	72313642	1	MOLDED PIECE	
13	72611218	2	CLIP	
14	72417078	1	HOSE PIECE	
15	72316562	1	CLIP	
16	72611218	1	CLIP	
17	72342712	1	HOSE BARB	
18	72417109	1	SEALING WASHER	
19	72417079	1	ADAPTER NIPPLE	
20	72622285	1	SEALING WASHER	
21	72417080	1	OIL RETURN LINE	
22	72423359	1	GASKETS	
23	72417081	1	OIL RETURN LINE	
24	72312631	1	HOSE	
25	72611218	2	CLIP	

FAVORIT 920 (920/00401-01000 & 03001-06000)
35984

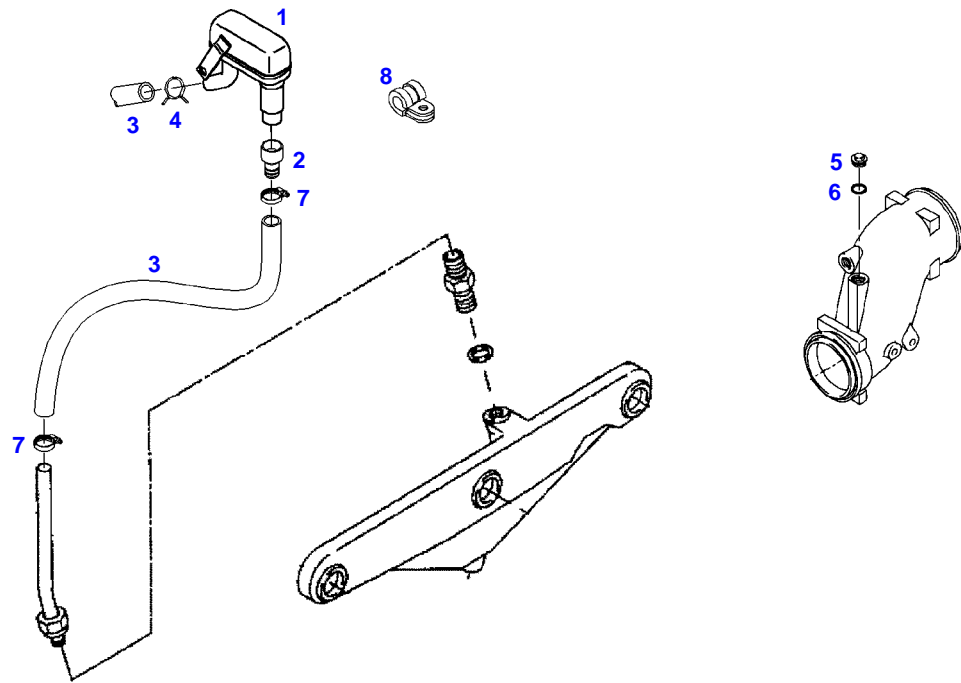

035984

Item	Part Number	Qty	Description Comments	Technical Specification
			CHANGE TO OPEN CRANKCASE VENTILATION	
1	72451208	1	BLEEDER VALVE	
2	72454834	1	REDUCER	
3	72451209	2	HOSE	
4	72431275	1	CLAMP	
5	72373973	1	DRAIN PLUG	DIN 910 M18X1,5-ST
6	72315099	1	SEALING WASHER	DIN 7603 A18X22-CU
7	72311166	2	HOSE CLIP	
8	72373549	1	PIPE CLAMP	

FAVORIT 920 (920/00401-01000 & 03001-06000)
40535

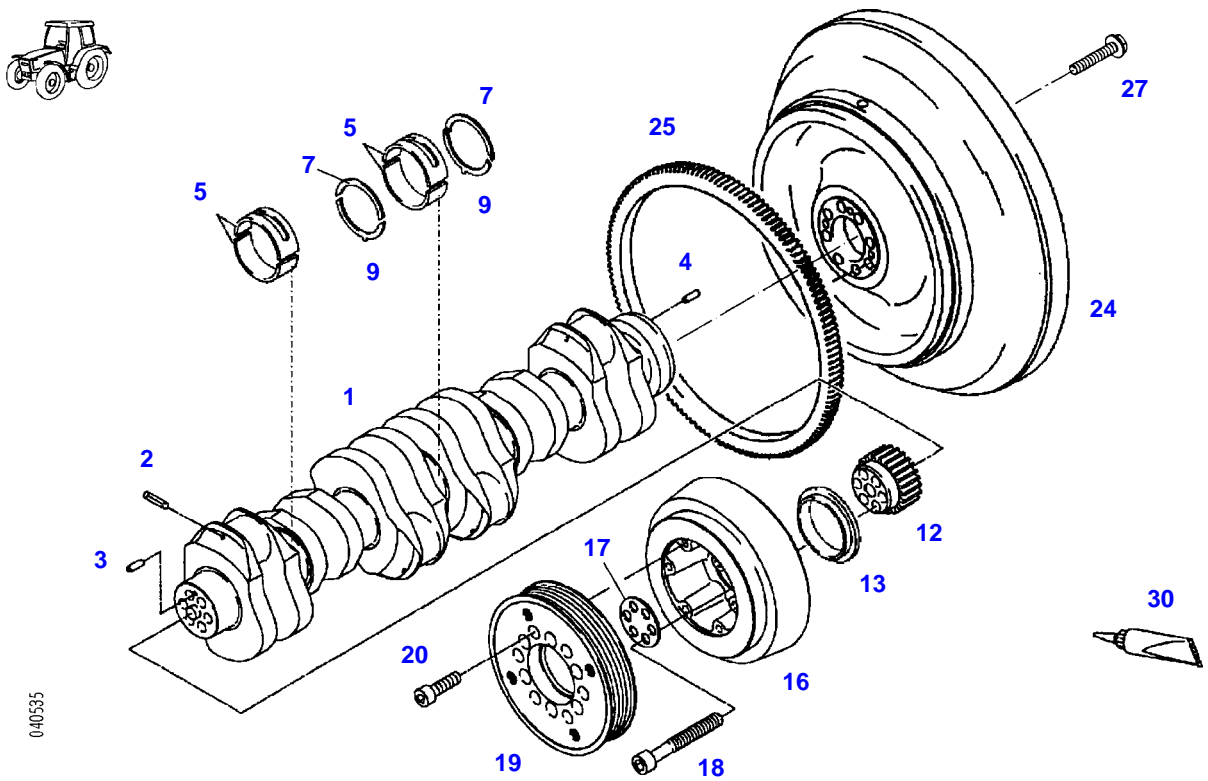

Item	Part Number	Qty	Description Comments	Technical Specification
1	72417087	1	CRANKSHAFT	
2	72417088	6	SEALING PLUG	
3	72313817	1	TENSIONING PIN	ISO8752-6X16-A-ST-ZNPHR10F-KOE
4	72313849	1	TENSIONING PIN	ISO8750-8X24-ST
5	72417089	7	MAIN BEARING	
	72417090	7	MAIN BEARING REPAIR STEP	
7	72417091	2	THRUST WASHER	
	72417092	2	THRUST WASHER REPAIR STEP	
9	72417093	2	THRUST WASHER	
	72417094	2	THRUST WASHER REPAIR STEP	
12	72316540	1	CRANKSHAFT GEAR	
13	72315016	1	SPRAYER RING	
16	72311632	1	VIBRATION DAMPER	
17	72311934	1	DISC	
18	72315396	6	SOCKET HEAD BOLT	M14X1,5X105-12.9-PHR
19	72419905	1	BELT PULLEY	
20	72315497	6	SOCKET HEAD BOLT	DIN 912 M10X35-10.9
24	72417095	1	FLYWHEEL ><25	
25	72312391	1	RING GEAR	
27	72315372	8	HEX BOLT, WITH COLLAR	
30	72311272	1	SEALING COMPOUND	

FAVORIT 920 (920/00401-01000 & 03001-06000)
8735

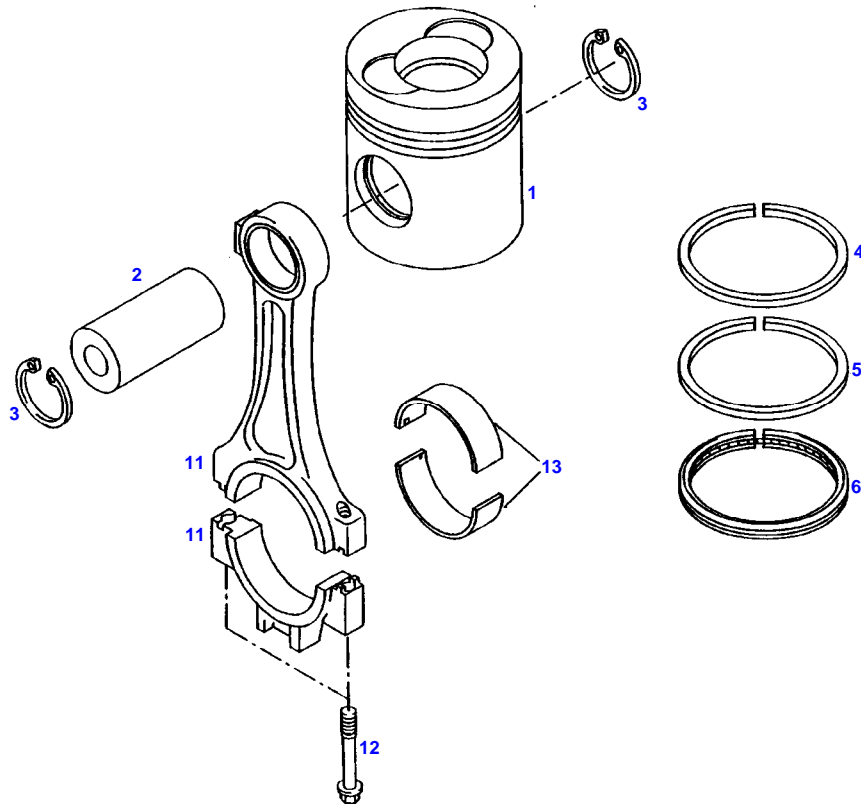

8735

Item	Part Number	Qty	Description Comments	Technical Specification
1	72417096	6	PISTON ><2-6 <-- 920/0401 --> 920/0700 <-- 920/3001 --> 920/4060 <-- 920/4062 --> 920/4140 <-- F926.202.310.320	
	72426465	6	PISTON ><2-6 <-- 920/4061 --> 920/4061 <-- 920/4141	
2			NOT AVAILABLE IN SINGLE PARTS	
3	72311096	12	LOCK WASHER	DIN 472-42X1,75
4	72417097	6	KEYSTONE RING	
5	72317292	6	TAPERED COMPRESSION RING	
6	72315017	6	WEDGE-SECTION RING <-- 920/0401 --> 920/0700 <-- 920/3001 --> 920/4060 <-- 920/4062 --> 920/4140	
	72426466	6	WEDGE-SECTION RING <-- 920/4061 --> 920/4061 <-- 920/4141	
11	72428723	6	PISTON ROD ><12	
12	72417099	12	WASHER HEAD BOLT REPLACE SCREWS SETWISE SCREWS-TO BE USED ONCE ONLY	
13	72417100	6	CONNECTING ROD BEARING	
	72417101	6	CONNECTING ROD BEARING REPAIR STEP 69,90MM	

FAVORIT 920 (920/00401-01000 & 03001-06000)
10151

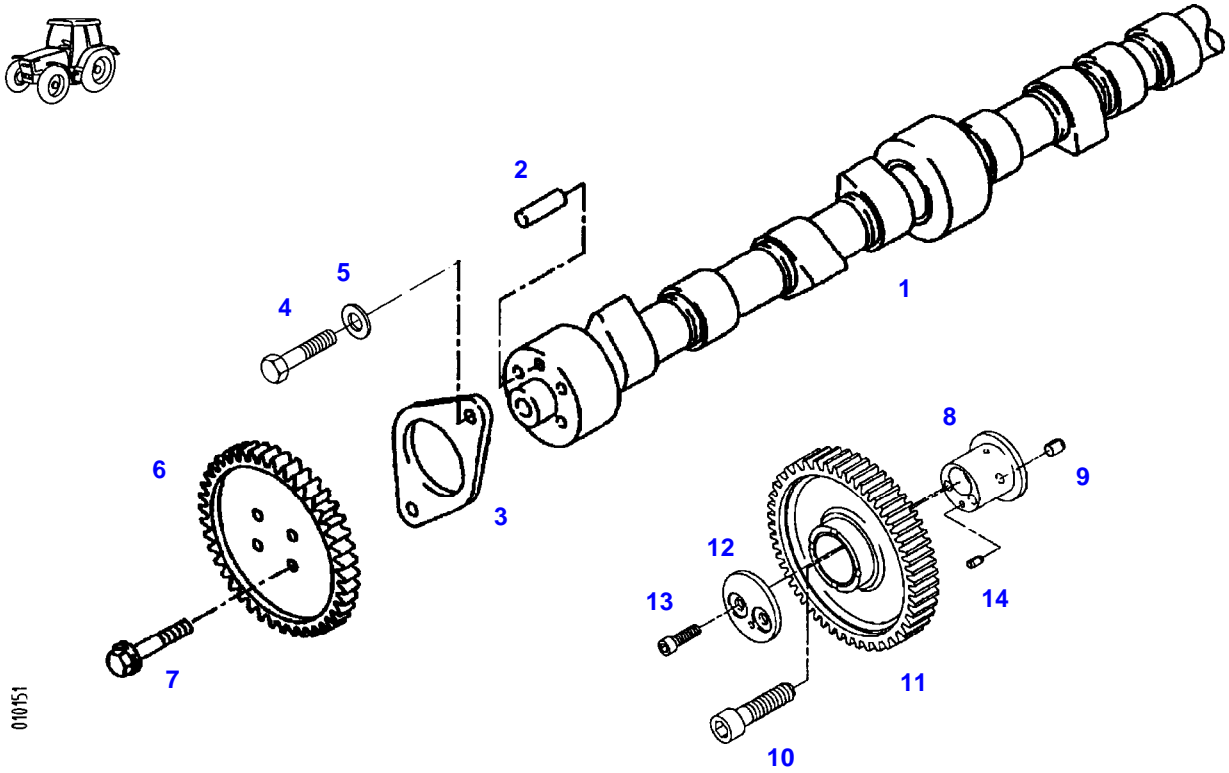

010151

Item	Part Number	Qty	Description Comments	Technical Specification
1	72417110	1	CAMSHAFT <-- 920/0401 --> 920/0700 <-- 920/3001 --> 920/4060 <-- 920/4062 --> 920/4140	
	72426468	1	CAMSHAFT ><2 <-- 920/4061 --> 920/4061 <-- 920/4141	
2	72313859	1	CYLINDER PIN	DIN 7-8M6X18-ST50K
3	72312126	1	FLANGE	
4	72315642	1	HEXAGONAL HEAD BOLT	DIN 933 M8 X 16-8.8A3L
5	72311788	1	DISC	DIN 125-8,4-ST.A3L
6	72416958	1	CAM WHEEL	
7	72315385	4	HEX BOLT, WITH COLLAR	
8	72310408	1	BOLT ><9,14	
9	72313847	1	TENSIONING PIN	ISO8750-8X10-ST
10	72315373	1	SOCKET HEAD BOLT	
11	72317157	1	INTERMEDIATE GEAR	
12	72317117	1	THRUST WASHER	
13	72315776	2	SOCKET HEAD BOLT	DIN 6912 M8X30-8.8
14	72313846	1	TENSIONING PIN	ISO8750-5X10-ST

FAVORIT 920 (920/00401-01000 & 03001-06000)
10157

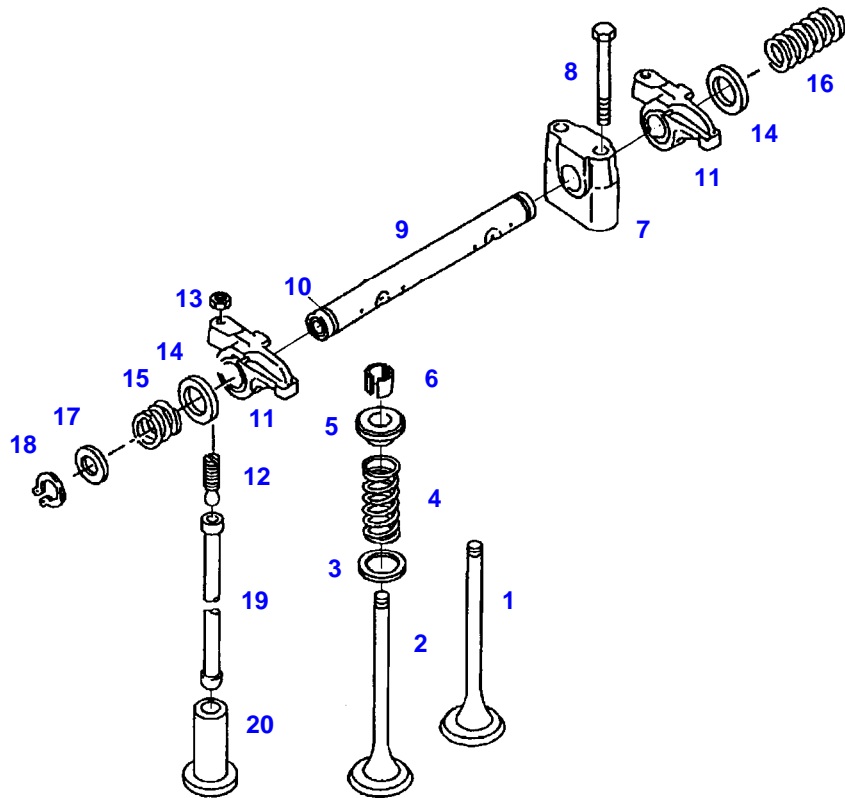

010157

Item	Part Number	Qty	Description Comments	Technical Specification
1	72317040	6	INTAKE VALVE	
2	72317039	6	OUTLET VALVE	
3	72311770	12	DISC	
4	72426516	12	VALVE SPRING	
5	72314931	12	VALVE SPRING RETAINER	
6	72311279	24	VALVE SPRING KEY	
7	72310123	6	ROCKER ARM SUPPORT	
8	72310402	12	TORX SCREW REPLACE SCREWS SETWISE	
9	72310120	3	ROCKER SHAFT ><10	
10	72314700	6	PLUG	
11	72604686	12	ROCKER ARM	
12	72315386	12	PRESSURE SCREW	
13	72313252	12	NUT	
14	72311769	12	DISC	
15	72316451	6	COMPRESSION SPRING	
16	72316450	3	COMPRESSION SPRING	
17	72317112	6	MACHINE WASHER	
18	72311061	6	LOCK WASHER	DIN 471-20X1,2
19	72316921	12	PUSH ROD	
20	72316919	12	VALVE TAPPET 20,00MM	

FAVORIT 920 (920/00401-01000 & 03001-06000)
32008

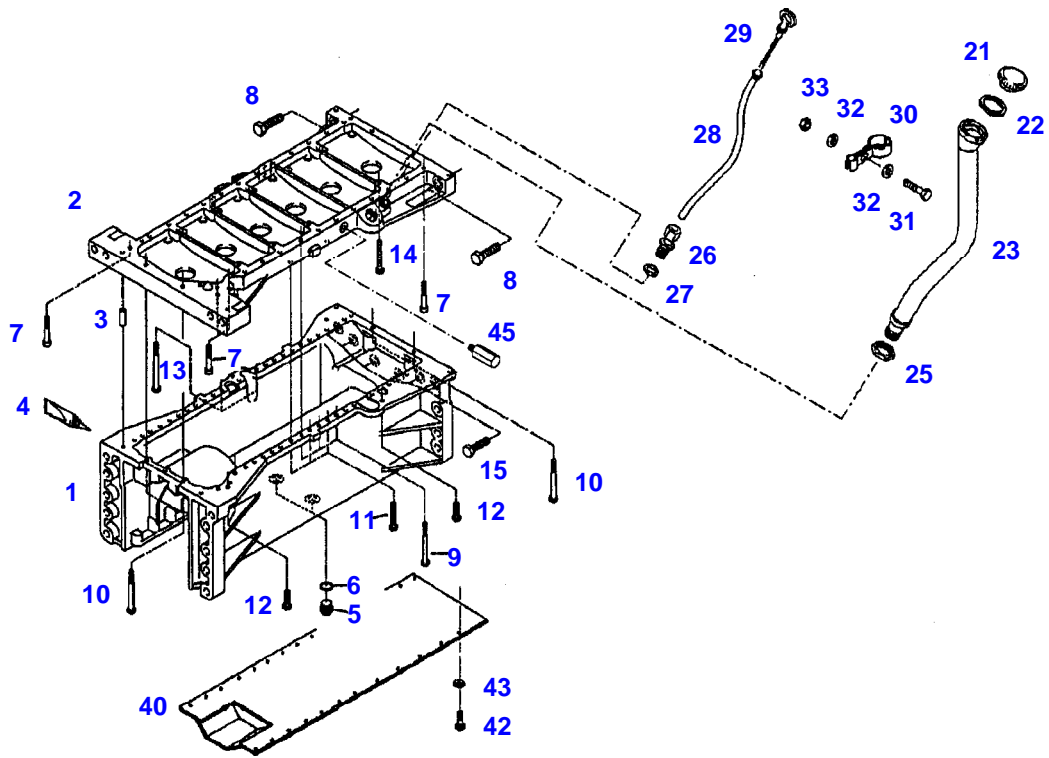

032008

Item	Part Number	Qty	Description Comments	Technical Specification
1	72417112	1	OIL PAN ><2+3	
2			NOT AVAILABLE IN SINGLE PARTS	
3	72313723	2	CENTERING PIN	
4	72602309	1	SEALING COMPOUND	
5	72315802	2	SCREW	DIN 7604 AM22X1,5-ST
6	72622285	2	SEALING WASHER	
7	72315480	5	SOCKET HEAD BOLT	DIN 912-M8X50-10.9-ZNPHR3F
8	72315597	2	HEXAGONAL HEAD BOLT	DIN 931-M18X65-10.9-ZNPHR3F
9	72315538	21	HEXAGONAL HEAD BOLT	DIN 931-M8X80-10.9-ZNPHR3F
10	72315538	4	HEXAGONAL HEAD BOLT	DIN 931-M8X80-10.9-ZNPHR3F
11	72315666	21	HEXAGONAL HEAD BOLT	DIN 933 M8X50-10.9 ZNPHR3F
12	72315656	3	HEXAGONAL HEAD BOLT	DIN 933-M8X30-10.9
13	72315540	2	HEXAGONAL HEAD BOLT	DIN 931 M8X100-10.9
14	72374161	8	HEXAGONAL HEAD BOLT	DIN 931 M8X60 GWA-10.9
15	72315739	6	HEXAGONAL HEAD BOLT	DIN 933 M16X60 GWA-10.9
21	72311395	1	COVER	
22	72312231	1	SEAL	
23	72316293	1	OIL FILLER NECK	
25	72313251	1	NUT	
26	72311313	1	STRAIGHT THREADED CONNECTION	DIN 2353-CL10-A-ST
27	72422299	1	SEALING WASHER	
28	72316957	1	GUIDE TUBE	
29	72311667	1	DIPSTICK	
30	72311224	2	PIPE CLAMP	
31	72315660	1	HEXAGONAL HEAD BOLT	DIN 933 M8X35-8.8A3L
32	72311788	2	DISC	DIN 125-8,4-ST.A3L
33	72313268	1	NUT	DIN 934 M8-8A3L
40	72418244	1	COVER PLATE	
42	72315688	25	HEXAGONAL HEAD BOLT	M10 X 35 CL10.9
43	72315054	25	SPLIT WASHER	FWN 65208-10-A3L
45	72313922	1	STUD BOLT	

Item	Part Number	Qty	Description Comments	Technical Specification
1	72312754	1	PUMP HOUSING	
2	72609443	1	OIL IMPELLER	
	72608305	1	OIL IMPELLER	
4	72608305	1	OIL IMPELLER	
	72609443	1	OIL IMPELLER	
6	72315649	3	HEXAGONAL HEAD BOLT	DIN 933 M8X20-10.9
7	72311788	3	DISC	DIN 125-8,4-ST.A3L
8	72317160	1	DRIVE GEAR	
9	72317123	1	SPRING WASHER	DIN 137 B12-ZNPHR
10	72372881	1	NUT	DIN 936 M12X1,5-17H A3L
11	72316956	1	JOINT TUBE	
12	72314366	1	PISTON	
13	72316448	1	COMPRESSION SPRING	
14	72423359	1	GASKETS	
15	72315382	1	SCREW	
16	72417104	1	OIL SUCTION LINE	
			><22	
17	72312262	1	SEAL	
18	72311788	3	DISC	DIN 125-8,4-ST.A3L
19	72315541	2	HEXAGONAL HEAD BOLT	DIN 931 M8X100-8.8
20	72310665	1	DISTANCE BUSHING	
21	72315653	1	HEXAGONAL HEAD BOLT	DIN 933 M8 X 25-8.8A3L
22			NOT AVAILABLE IN SINGLE PARTS	
23	72313529	2	SEAL	

FAVORIT 920 (920/00401-01000 & 03001-06000)
F51387

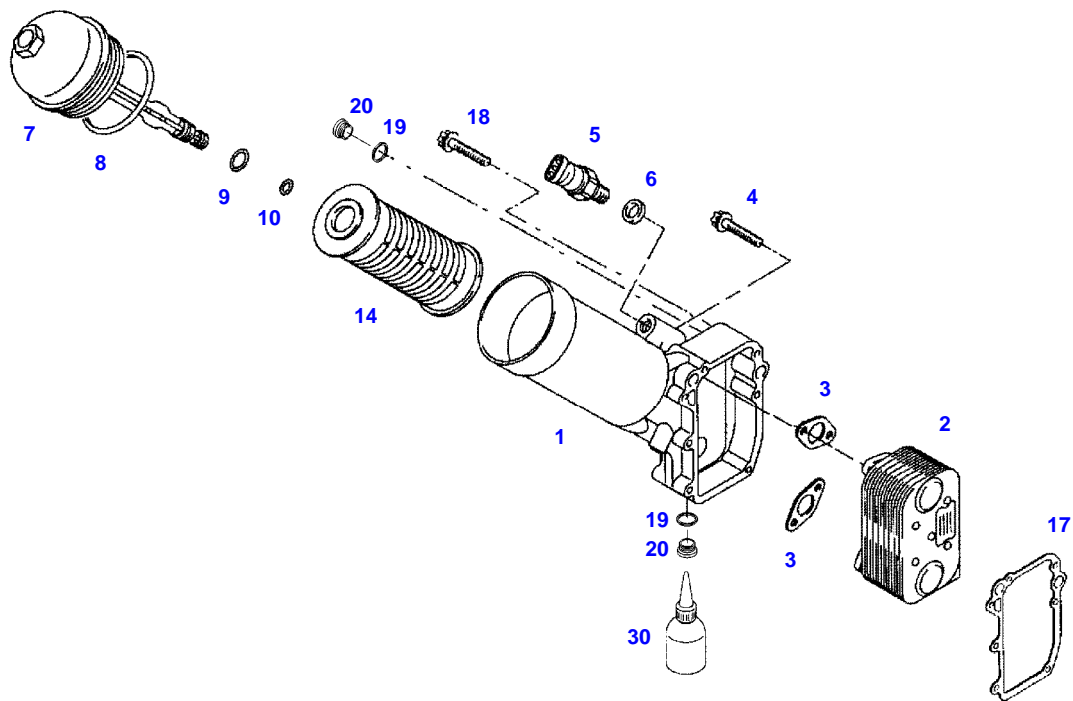

051387



Item	Part Number	Qty	Description Comments	Technical Specification
1	72426473	1	OIL FILTER HEAD ><2-10	
2	72311378	1	OIL COOLER	
3	72312256	2	SEAL	
4	72423410	4	WASHER HEAD BOLT	
5			SEE ELECTRICAL SYSTEM TRANSMITTER	
6	72422299	1	SEALING WASHER	
7	72417084	1	COVER ><8-10	
8	72318003	1	SEAL	
9	72417085	1	SEAL 6X2	
10	72417086	1	SEAL 10X2	
14	72317863	1	OIL FILTER	
17	72417107	1	SEAL	
18	72455491	7	HEXAGONAL HEAD BOLT	
19	72417109	2	SEALING WASHER	
20	72315440	2	PLUG SCREW	DIN 908 M18 X 1,5-ST
	72482917	2	THREADED BUSHING WITHOUT PICTURE NO. 21	
30	72313159	1	ADHESIVE FOR POSITION 21	LOCTITE 648 50ML

FAVORIT 920 (920/00401-01000 & 03001-06000)
40564

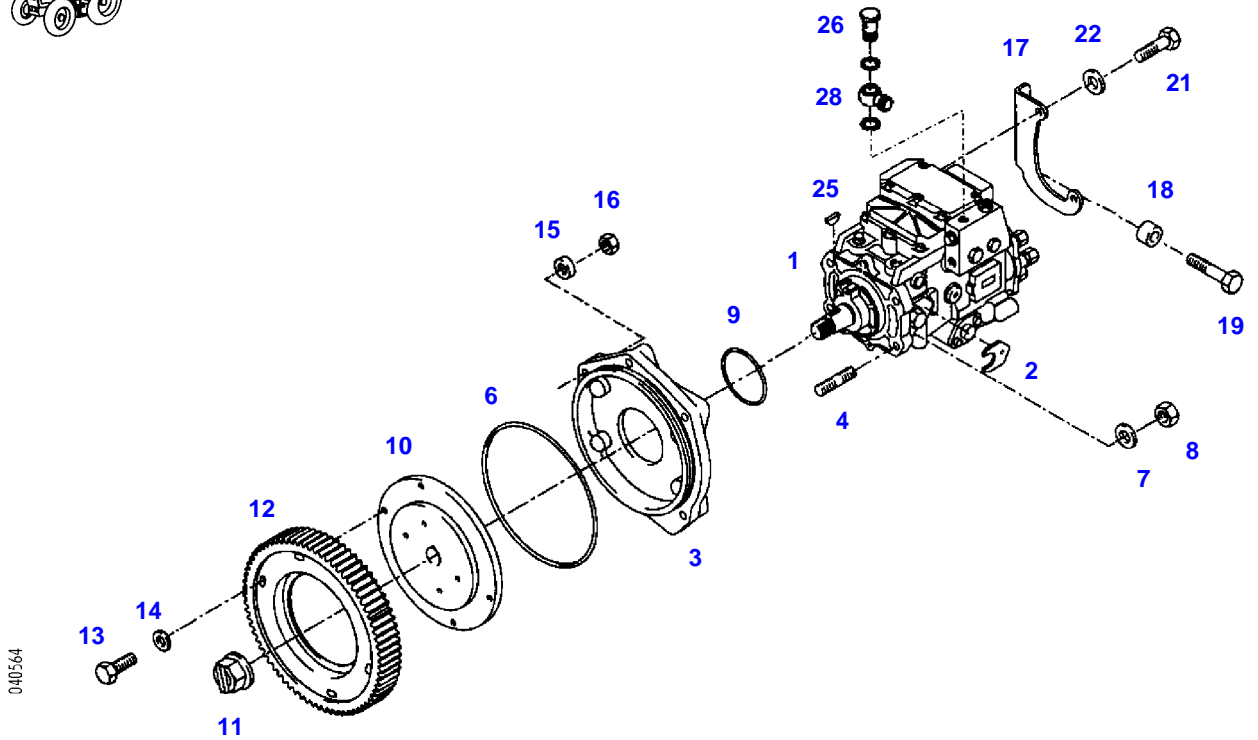

040564

Item	Part Number	Qty	Description Comments	Technical Specification
			<-- 920/0401 --> 920/0700 <-- 920/3001 --> 920/4060 <-- 920/4062 --> 920/4140	
1	72317933	1	INJECTION PUMP ><25	
2	72417117	1	SPACER	
3	72417118	1	MOUNTING FLANGE ><4	
4	72415291	4	STUD BOLT	
6	72313510	1	O-RING	140X4-NBR 70 FWN56402
7	72311789	4	DISC	DIN 125-10,5-ST.A3L
8	72313271	4	NUT	DIN 934 M10-8
9	72313536	1	SEAL	
10	72417120	1	HUB	
11	72417121	1	NUT	
12	72417122	1	DRIVE GEAR	
13	72315656	4	HEXAGONAL HEAD BOLT	DIN 933-M8X30-10.9
14	72311762	4	WASHER	
15	72311789	4	DISC	DIN 125-10,5-ST.A3L
16	72313271	4	NUT	DIN 934 M10-8
17	72422178	1	RETAINER	
18	72425791	1	SPACER BUSHING <>	
	72315666	1	HEXAGONAL HEAD BOLT	DIN 933 M8X50-10.9 ZNPHR3F
19	72315666	1	HEXAGONAL HEAD BOLT	DIN 933 M8X50-10.9 ZNPHR3F
	72315658	1	HEXAGONAL HEAD BOLT	DIN 933 M8X35-10.9
21	72315651	2	HEXAGONAL HEAD BOLT	DIN 933 M8X22-8.8A3L
22	72311773	2	DISC	
25	72316454	1	WOODRUFF KEY	DIN 6888-4X6,5-ST60
26			SEE FUEL PUMP FUEL LINES	
28			SEE FUEL PUMP FUEL LINES	

FAVORIT 920 (920/00401-01000 & 03001-06000)
33200

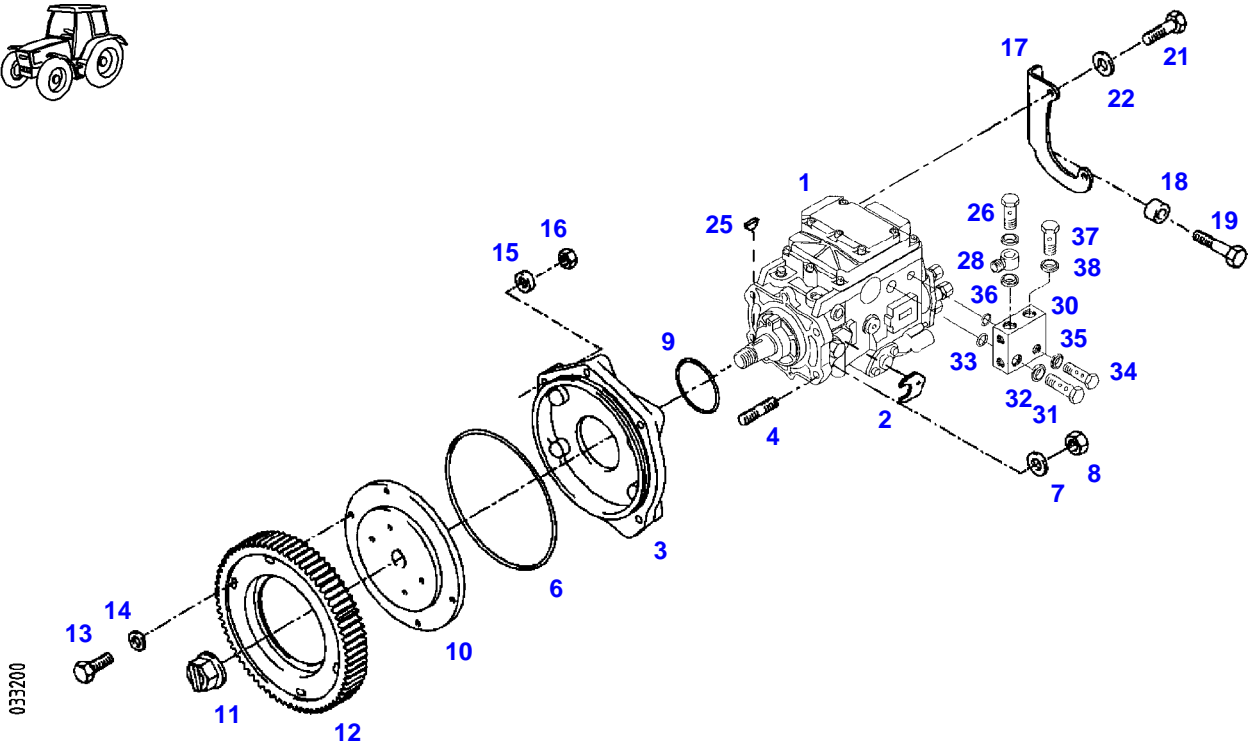

Item	Part Number	Qty	Description Comments	Technical Specification
			<-- 920/4061 --> 920/4061 <-- 920/4141	
1	72426478	1	INJECTION PUMP ><25,30-38	
2	72417117	1	SPACER	
3	72417118	1	MOUNTING FLANGE ><4	
4	72415291	4	STUD BOLT	
6	72313510	1	O-RING	140X4-NBR 70 FWN56402
7	72311789	4	DISC	DIN 125-10,5-ST.A3L
8	72313271	4	NUT	DIN 934 M10-8
9	72313536	1	SEAL	
10	72417120	1	HUB	
11	72417121	1	NUT	
12	72417122	1	DRIVE GEAR	
13	72315656	4	HEXAGONAL HEAD BOLT	DIN 933-M8X30-10.9
14	72311762	4	WASHER	
15	72311789	4	DISC	DIN 125-10,5-ST.A3L
16	72313271	4	NUT	DIN 934 M10-8
17	72422178	1	RETAINER	
18	72425791	1	SPACER BUSHING	
19	72315666	1	HEXAGONAL HEAD BOLT	DIN 933 M8X50-10.9 ZNPHR3F
21	72315651	2	HEXAGONAL HEAD BOLT	DIN 933 M8X22-8.8A3L
22	72311773	2	DISC	
25	72316454	1	WOODRUFF KEY	DIN 6888-4X6,5-ST60
26			SEE FUEL PUMP FUEL LINES	
28			SEE FUEL PUMP FUEL LINES	
30	72426479	1	HOUSING	
31	72426480	1	BANJO BOLT	
32	72422299	1	SEALING WASHER	
33	72426481	1	SEAL	
34	72426482	1	BANJO BOLT	
35	72426483	1	SEALING WASHER	
36	72426484	1	SEAL	
37	72426485	1	BLEED AND DRAIN VALVE	
38	72422299	1	SEALING WASHER	

FAVORIT 920 (920/00401-01000 & 03001-06000)
31973

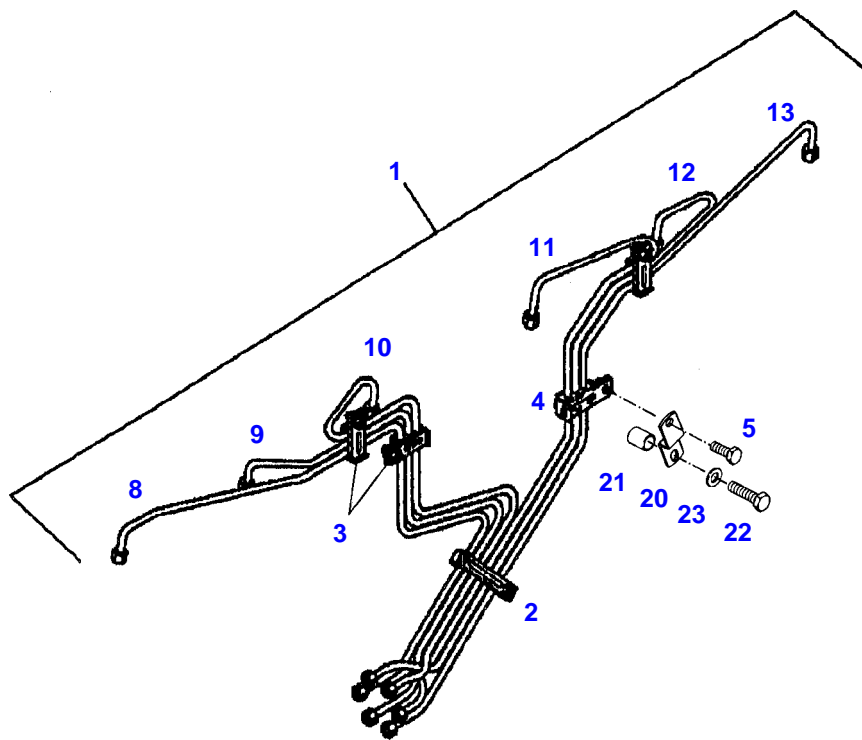

031973



Suggest:

For more complete manuals. Please go to the home page.

<https://www.ebooklibonline.com>

If the above button click is invalid. Please download this document first, and then click the above link to download the complete manual.

Thank you so much for reading

FUEL PRESSURE LINES

Item	Part Number	Qty	Description Comments	Technical Specification
1	72317934	1	INJECTION LINE SET ><2-13	
2	72417125	1	FASTENING COLLAR	
3	72417126	3	FASTENING COLLAR	
4	72417127	1	FASTENING COLLAR	
5	72315629	1	HEXAGONAL HEAD BOLT	DIN 933 M6 X 12-8.8A3L
8			NOT AVAILABLE IN SINGLE PARTS	
9			NOT AVAILABLE IN SINGLE PARTS	
10			NOT AVAILABLE IN SINGLE PARTS	
11			NOT AVAILABLE IN SINGLE PARTS	
12			NOT AVAILABLE IN SINGLE PARTS	
13			NOT AVAILABLE IN SINGLE PARTS	
20	72421723	1	RETAINER ENG.NO. <-- 164 6500 000 <> --> 164 9725 999 <> <>	
	72315629	1	HEXAGONAL HEAD BOLT	DIN 933 M6 X 12-8.8A3L
21	72421724	1	BUSHING ENG.NO. <-- 164 6500 000 --> 164 9725 999	
22	72315634	1	HEXAGONAL HEAD BOLT ENG.NO. <-- 164 6500 000 --> 164 9725 999	DIN 933 M6X30-8.8A3L
	72315629	1	HEXAGONAL HEAD BOLT ENG.NO. <-- 164 9726 001 --> 164 9999 999 <-- 164 0001 000 --> 164 6499 999	DIN 933 M6 X 12-8.8A3L
23	72311787	1	DISC	DIN 125-6,4-ST.A3L

FAVORIT 920 (920/00401-01000 & 03001-06000)
40547

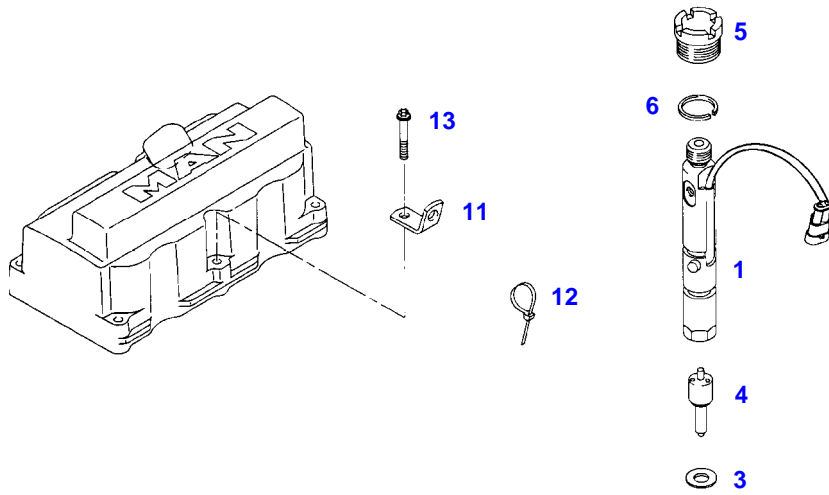

040547

<https://www.ebooklibonline.com>

Hello dear friend!

Thank you very much for reading.

Enter the link into your browser.

The full manual is available for immediate download.

<https://www.ebooklibonline.com>