

<b>Page Number</b>	<b>Page Title</b>	<b>Page Reference</b>
01-000-TOC	ENGINE, FUEL AND EXHAUST SYSTEM	01-000-TOC
02-000-TOC	AXLES	02-000-TOC
03-000-TOC	STEERING SYSTEM	03-000-TOC
04-000-TOC	DRIVE TRAIN SYSTEM	04-000-TOC
05-000-TOC	COMPRESSED AIR SYSTEM	05-000-TOC
06-000-TOC	HYDRAULIC SYSTEM	06-000-TOC
07-000-TOC	ELECTRICAL SYSTEM	07-000-TOC
08-000-TOC	CAB	08-000-TOC
09-000-TOC	AIR CONDITIONING AND HEATING SYSTEM	09-000-TOC
10-000-TOC	CHASSIS	10-000-TOC
11-000-TOC	WHEELS	11-000-TOC
12-000-TOC	IMPLEMENT LIFT SYSTEM FRONT	12-000-TOC
13-000-TOC	IMPLEMENT LIFT SYSTEM REAR	13-000-TOC
14-000-TOC	ACCESSORIES	14-000-TOC

Page Number	Page Title	Page Reference
01-0001	CRANKCASE	2020
01-0002	PUMP DRIVE	2030
01-0003	FRONT COVER	2040
01-0004	FLYWHEEL HOUSING	2050
01-0005	CYLINDER HEAD	2060
01-0006	ENGINE BREATHING	2065
01-0007	ENGINE BREATHING CHANGE TO OPEN CRANKCASE VENTILATION	2066
01-0008	CRANKSHAFT	2070
01-0009	PISTON	2080
01-0010	CAMSHAFT	2090
01-0011	VALVE DRIVE	2100
01-0012	OIL PAN	2110
01-0013	GEAR PUMP	2120
01-0014	OIL FILTER/-COOLER	2130
01-0015	INJECTION PUMP <-- 916/0401 --> 916/0700 <-- 916/3001 --> 916/4059 <-- 916/4061 --> 916/4150	2150
01-0016	INJECTION PUMP <-- 916/4060 --> 916/4060 <-- 916/4151	2151
01-0017	FUEL PRESSURE LINES	2160
01-0018	INJECTOR VALVE NEEDLE MOTION SENSOR	2170
01-0019	INJECTOR VALVE <-- 916/0401 --> 916/0700 <-- 916/3001 --> 916/4059 <-- 916/4061 --> 916/4150	2180
01-0020	INJECTOR VALVE <-- 916/4060 --> 916/4060 <-- 916/4151	2181
01-0021	LEAK OIL LINE	2190
01-0022	FUEL PUMP FUEL LINES	2200
01-0023	FUEL FILTER	2210
01-0024	HAND PRIMER ENGINE NUMBER <-- 164 9200 000 .... --> 164 9854 999 ....	2220
01-0025	HAND PRIMER ENGINE NUMBER <-- 164 9855 001 .... --> 164 9999 999 .... <-- 164 0001 000 .... --> 164 9199 999 ....	2221
01-0026	PREFILTER	2240
01-0027	FUEL TANK LEFT	2250
01-0028	FUEL TANK RIGHT <-- 916/0401 --> 916/0800 <-- 916/3001 --> 916/3056	2260
01-0029	FUEL TANK RIGHT <-- 916/3057	2262
01-0030	FUEL TANK BREATHING LINE <-- 916/0401 --> 916/0619	2265
01-0031	FUEL TANK BREATHING LINE <-- 916/0620 --> 916/0700 <-- 916/3001 --> 916/3056	2266

Page Number	Page Title	Page Reference
01-0032	FUEL TANK BREATHING LINE <-- 916/3057	2268
01-0033	COLD STARTING AID	2280
01-0034	WATER COOLED RADIATOR <-- 916/0501 --> 916/0600	2300
01-0035	WATER COOLED RADIATOR <-- 916/0401 --> 916/0500 <-- 916/0601 --> 916/0700 <-- 916/3001 --> 916/3086	2305
01-0036	WATER COOLED RADIATOR <-- 916/3087 --> 916/3183	2307
01-0037	WATER COOLED RADIATOR <-- 916/3184	2308
01-0038	COOL. WATER PIPING	2310
01-0039	WATER PUMP ENGINE NUMBER <-- 164 9200 000 .... --> 164 9495 999 ....	2350
01-0040	WATER PUMP ENGINE NUMBER <-- 164 9496 001 .... --> 164 9999 999 .... <-- 164 0001 000 .... --> 164 9199 999 ....	2351
01-0041	COLL. WATER PIPING	2360
01-0042	AIR FILTER <-- 916/0401 --> 916/0642 <-- 916/0644 --> 916/0700 <-- 916/3001 --> 916/3001 <-- 916/3003 --> 916/3006 <-- 916/3008 --> 916/3010 <-- 916/3013 --> 916/3014 <-- 916/3016 --> 916/3022 <-- 916/3024 --> 916/3028 <-- 916/3030 --> 916/3035 <-- 916/3037 --> 916/3039 <-- 916/3041 --> 916/3042 <-- 916/3044 --> 916/3044 <-- 916/3047 --> 916/3047 <-- 916/3049 --> 916/3049 <-- 916/3053 --> 916/3053	2370
01-0043	EJECTOR ASSY. AIR CLEANER RETRO FIT POSSIBLE <-- 916/0401 --> 916/0642 <-- 916/0644 --> 916/0700 <-- 916/3001 --> 916/3001 <-- 916/3003 --> 916/3006 <-- 916/3008 --> 916/3010 <-- 916/3013 --> 916/3014 <-- 916/3016 --> 916/3022 <-- 916/3024 --> 916/3028 <-- 916/3030 --> 916/3035 <-- 916/3037 --> 916/3039 <-- 916/3041 --> 916/3042 <-- 916/3044 --> 916/3044 <-- 916/3047 --> 916/3047 <-- 916/3049 --> 916/3049 <-- 916/3053 --> 916/3053	2371

**<https://www.ebooklibonline.com>**

Hello dear friend!

Thank you very much for reading.

Enter the link into your browser.

The full manual is available for immediate download.

**<https://www.ebooklibonline.com>**

Page Number	Page Title	Page Reference
01-0044	AIR FILTER <-- 916/0643 --> 916/0643 <-- 916/3002 --> 916/3002 <-- 916/3007 --> 916/3007 <-- 916/3011 --> 916/3012 <-- 916/3015 --> 916/3015 <-- 916/3023 --> 916/3023 <-- 916/3029 --> 916/3029 <-- 916/3036 --> 916/3036 <-- 916/3040 --> 916/3040 <-- 916/3043 --> 916/3043 <-- 916/3045 --> 916/3046 <-- 916/3048 --> 916/3048 <-- 916/3050 --> 916/3052 <-- 916/3054 --> 916/3056 <-- 916/3057 --> 916/3184	2375
01-0045	EJECTOR ASSY. AIR CLEANER RETRO FIT POSSIBLE <-- 916/0643 --> 916/0643 <-- 916/3002 --> 916/3002 <-- 916/3007 --> 916/3007 <-- 916/3011 --> 916/3012 <-- 916/3015 --> 916/3015 <-- 916/3023 --> 916/3023 <-- 916/3029 --> 916/3029 <-- 916/3036 --> 916/3036 <-- 916/3040 --> 916/3040 <-- 916/3043 --> 916/3043 <-- 916/3045 --> 916/3046 <-- 916/3048 --> 916/3048 <-- 916/3050 --> 916/3052 <-- 916/3054 --> 916/3056 <-- 916/3057 --> 916/3117	2376
01-0046	EJECTOR ASSY. AIR CLEANER RETRO FIT POSSIBLE <-- 916/3118 --> 916/3184	2377
01-0047	AIR FILTER <-- 916/3185	2378
01-0048	AIR FILTER SUCTION PIPE	2380
01-0049	BOOST INTERCOOLING	2390
01-0050	SUCTION PIPE	2420
01-0051	TURBO-SUPERCHARGER	2430
01-0052	TURBO-SUPERCHARGER OIL PRESSURE PIPE	2450
01-0053	EXHAUST BEND	2460
01-0054	EXHAUST <-- 916/0401 --> 916/0619	2470
01-0055	EXHAUST <-- 916/0620 --> 916/0700 <-- 916/3001	2475
01-0056	END PIPE	2480
01-0057	LICENCE PLATE HOLDER GERMANY EXHAUST UPRIGHT <-- 916/3001	2485
01-0058	EXHAUST BRAKE	2490
01-0059	SPEED CONTROL FOOT OPERATION	2500
01-0060	SPEED CONTROL MANUAL OPERATION <-- 916/0401 --> 916/0600	2510
01-0061	SPEED CONTROL MANUAL OPERATION <-- 916/0601 --> 916/0700	2515

<b>Page Number</b>	<b>Page Title</b>	<b>Page Reference</b>
01-0062	SPEED CONTROL MANUAL OPERATION <-- 916/3001	2516
01-0063	V-BELT	2680
01-0064	VISCO FAN	2700
01-0065	TENSION ROLLER	2710
01-0066	ENGINE PRE-HEATER <-- 916/0401 --> 916/0700 <-- 916/3001 --> 916/4002	2750
01-0067	ENGINE PRE-HEATER <-- 916/4003	2751

FAVORIT 916 (916/00401-01000 & 03001-06000)  
41076

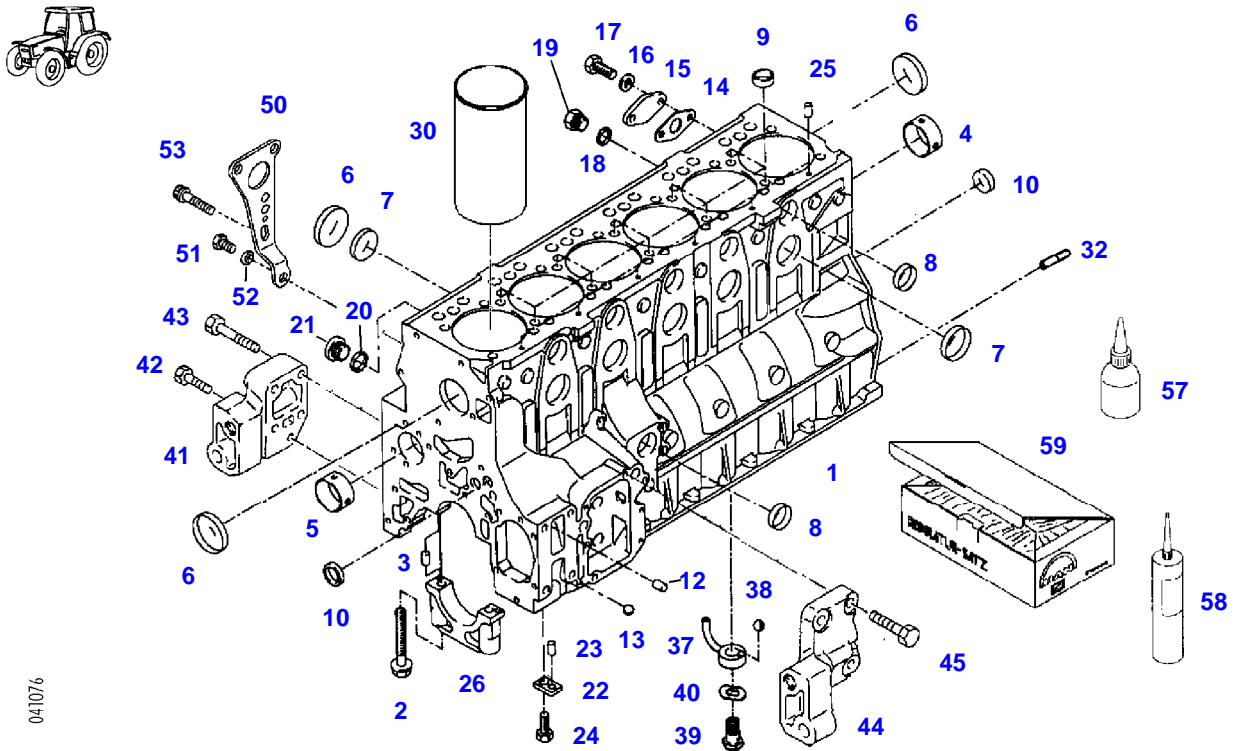

041076

Item	Part Number	Qty	Description Comments	Technical Specification
	72425112	1	SHORT ENGINE <-- 916/0401 --> 916/0700 <-- 916/3001 --> 916/4059 <-- 916/4061 --> 916/4150	
	72426537	1	SHORT ENGINE <-- 916/4060 --> 916/4060 <-- 916/4151	
1	72417053	1	CRANKCASE ><2-26	
2	72417054	14	HEX BOLT, WITH COLLAR M14X118	
3	72313719	2	CYLINDER PIN	
4	72417055	7	BEARING BUSHING	
	72417056	7	BEARING BUSHING OVERSIZE 0,03MM	
5	72417057	1	BEARING BUSHING <-- 916/0401 --> 916/0700 <-- 916/3001 --> 916/4059 <-- 916/4061 --> 916/4150	
	72426515	1	BEARING BUSHING <-- 916/4060 --> 916/4060 <-- 916/4151	
	72417058	1	BEARING BUSHING UNDERSIZE 0.03MM <-- 916/0401 --> 916/0700 <-- 916/3001 --> 916/4059 <-- 916/4061 --> 916/4150	
	72426460	1	BEARING BUSHING UNDERSIZE 0.03MM <-- 916/4060 --> 916/4060 <-- 916/4151	
6	72417059	8	COVER 62,15MM	
7	72311422	11	COVER 50,20MM	
8	72311424	6	COVER 40,20MM	
9	72311426	10	COVER	
10	72311432	2	COVER	
12	72314696	1	SEALING PLUG	
13	72310168	1	BALL	
14	72312268	1	SEAL	
15	72312125	1	FLANGE	
16	72311788	2	DISC	DIN 125-8,4-ST.A3L
17	72315650	2	HEXAGONAL HEAD BOLT	DIN 933 M8 X 20-8.8A3L
18	72422299	1	SEALING WASHER	
19	72315799	1	PLUG	DIN 7604 AM14X1,5-A3L
20	72417074	3	SEALING WASHER	
21	72315445	3	PLUG	DIN 908 M30X1,5-ST
22	72417060	1	LOCK PLATE ><23	
23	72420231	1	CYLINDER PIN	DIN 7-5M6X10-ST50-2K
24	72315705	1	HEXAGONAL HEAD BOLT	DIN 933 M12X20-8.8A3L
25	72420232	6	CYLINDER PIN	DIN 7-6M6X10-ST50-2K
26			NOT AVAILABLE IN SINGLE PARTS	
30	72313100	6	SLEEVE BUSHING	
	72431672	6	CYLINDER LINER COLLAR OVERSIZE 0.20MM	
32	72313721	2	CENTERING PIN	
37	72313230	6	OIL SPLASH NOZZLE ><38	
38			NOT AVAILABLE IN SINGLE PARTS	
39	72317037	6	OIL PRESSURE VALVE	
40	72317123	6	SPRING WASHER	DIN 137 B12-ZNPHR

## CRANKCASE

Item	Part Number	Qty	Description Comments	Technical Specification
41	72428719	1	ENGINE SUPPORT	
42	72315688	1	HEXAGONAL HEAD BOLT	M10 X 35 CL10.9
43	72315559	4	HEXAGONAL HEAD BOLT	DIN 931 M12X60 GWA-10.9
44	72428720	1	ENGINE SUPPORT	
45	72315713	4	HEXAGONAL HEAD BOLT	DIN 933 M12X40 GWA-10.9
50	72417061	1	SUSPENSION EYE	
51	72315721	1	HEXAGONAL HEAD BOLT	DIN 933 M14X25-8.8A3L
52	72311792	1	DISC	DIN125-15-ST
53			RE. EXHAUST MANIFOLD	
57	72313159	1	ADHESIVE	LOCTITE 648 50ML
58	72602309	1	SEALING COMPOUND	
59	72417062	1	SEAL KIT	

FAVORIT 916 (916/00401-01000 & 03001-06000)  
40530

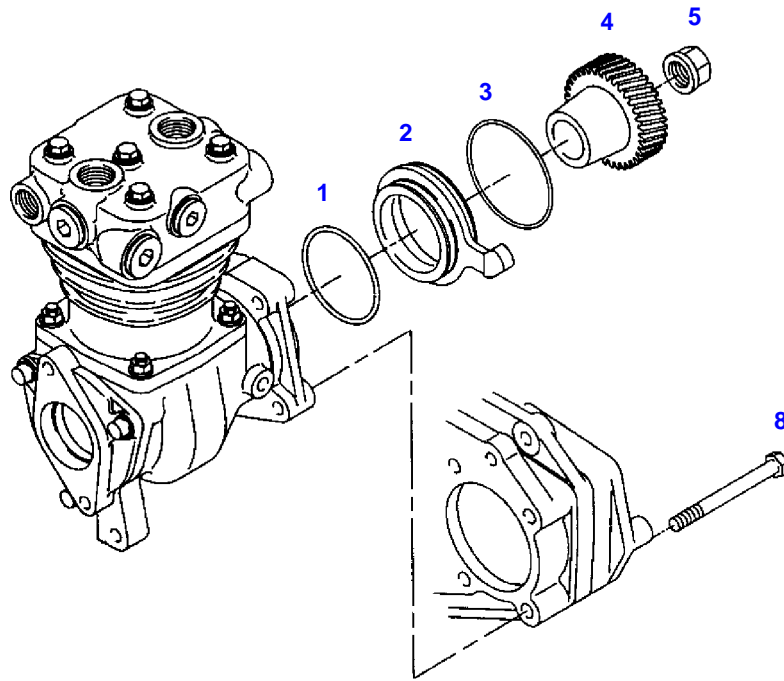

040530

<b>Item</b>	<b>Part Number</b>	<b>Qty</b>	<b>Description Comments</b>	<b>Technical Specification</b>
1	72313536	1	SEAL	
2	72312004	1	ECCENTRIC	
3	72313390	1	O-RING	
4	72417063	1	DRIVE GEAR	
5	72313333	1	WHEEL NUT	DIN74361-B20-8
8	72315551	4	HEXAGONAL HEAD BOLT	DIN 931 M10X100-8.8

FAVORIT 916 (916/00401-01000 & 03001-06000)  
40531

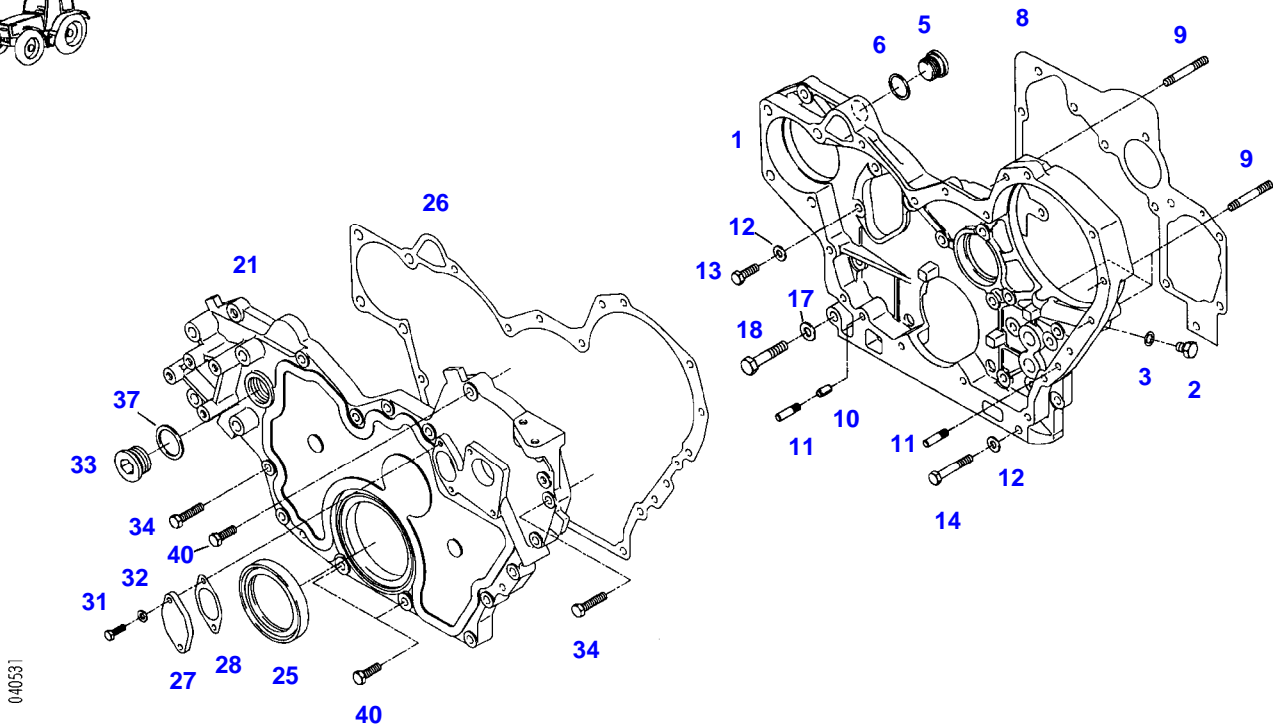

040531

Item	Part Number	Qty	Description Comments	Technical Specification
1	72312752	1	CONTROL HOUSING ><2-6	
2	72315627	1	HEXAGONAL HEAD BOLT	DIN 933 M6X8-8.8A3L
3	72417153	1	SEALING WASHER	
5	72315442	1	PLUG	DIN 908 M22X1,5-ST
6	72622285	1	SEALING WASHER	
8	72312259	1	SEAL	
9	72313712	4	STUD BOLT	
10	72313848	1	TENSIONING PIN	ISO8750-8X16-ST
11	72313720	2	CENTERING PIN	
12	72311788	12	DISC	DIN 125-8,4-ST.A3L
13	72315653	11	HEXAGONAL HEAD BOLT	DIN 933 M8 X 25-8.8A3L
14	72315529	1	HEXAGONAL HEAD BOLT	DIN 931 M8X50-8.8A3L
17	72311789	1	DISC	DIN 125-10,5-ST.A3L
18	72315544	1	HEXAGONAL HEAD BOLT	DIN 931 M10X50-8.8A3L
21	72428721	1	CRANKCASE END COVER	
25	72346310	1	SHAFT SEALING RINGS	
26	72312260	1	SEAL	
27	72417065	1	COVER	
28	72417066	1	SEAL	
31	72315625	2	HEXAGONAL HEAD BOLT	DIN 933 M6X16-8.8
32	72311787	2	DISC	DIN 125-6,4-ST.A3L
33	72315445	1	PLUG	DIN 908 M30X1,5-ST
34	72315663	12	HEXAGONAL HEAD BOLT	DIN 933 M8X40-8.8A3L
37	72417074	1	SEALING WASHER	
40	72315657	3	HEXAGONAL HEAD BOLT	DIN 933 M8 X 30-8.8A3L

FAVORIT 916 (916/00401-01000 & 03001-06000)  
40532

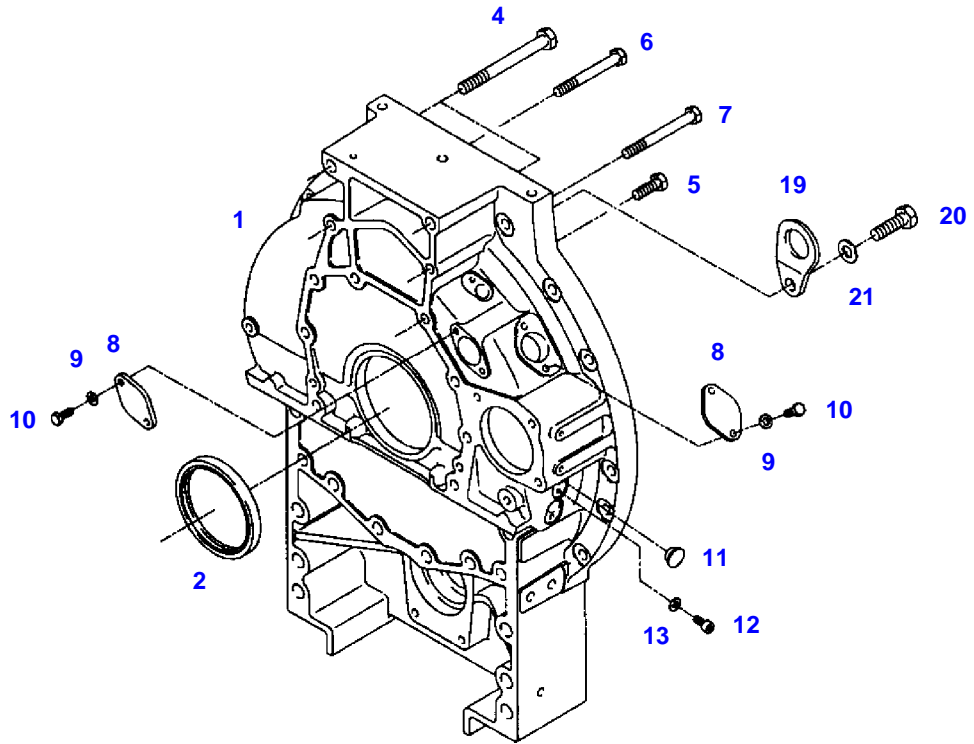

0440532

Item	Part Number	Qty	Description Comments	Technical Specification
1	72415318	1	FLYWHEEL HOUSING ><2	
2	72315031	1	SHAFT SEALING RINGS	
4	72315580	2	HEXAGONAL HEAD BOLT	DIN931-M14X140-10.9-ZNPHR3F
5	72315710	8	HEXAGONAL HEAD BOLT	DIN 933-M12X35 GWA-10.9
6	72315567	1	HEXAGONAL HEAD BOLT	DIN 931 M12X100 GWA-10.9
7	72315569	1	HEXAGONAL HEAD BOLT	DIN 931 M12X110 GWA-10.9
8	72312124	2	BLANK FLANGE	
9	72311788	4	DISC	DIN 125-8,4-ST.A3L
10	72315653	4	HEXAGONAL HEAD BOLT	DIN 933 M8 X 25-8.8A3L
11	72346444	2	LOCKING PLUG	
12	72374017	2	SOCKET HEAD BOLT	DIN 912 M8X12-8.8
13	72423360	2	GASKETS	
19	72423377	1	EYE	
20	72315721	1	HEXAGONAL HEAD BOLT	DIN 933 M14X25-8.8A3L
21	72311792	1	DISC	DIN125-15-ST

FAVORIT 916 (916/00401-01000 & 03001-06000)  
40533

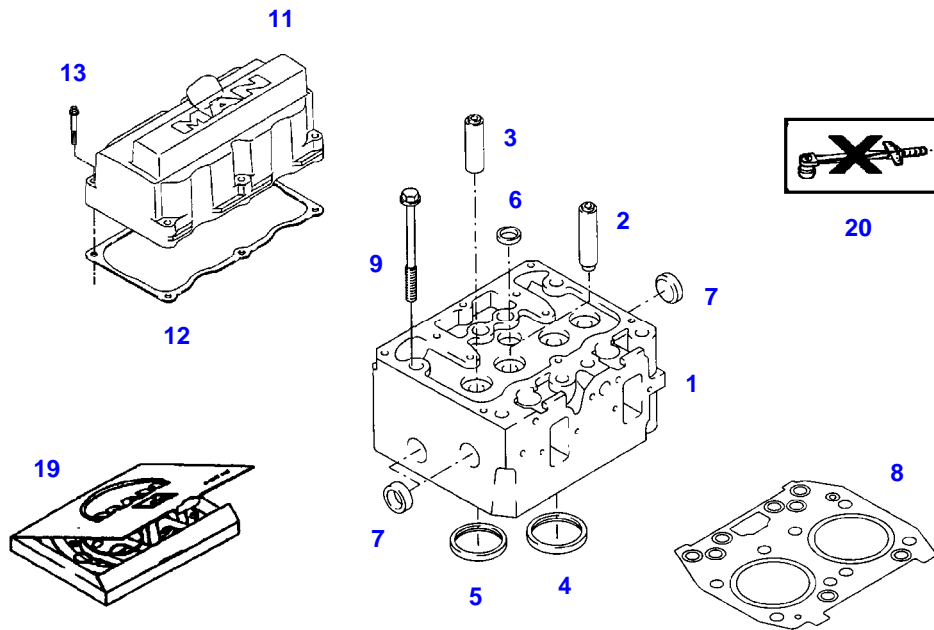

040533

## CYLINDER HEAD

Item	Part Number	Qty	Description Comments
1	72417067	3	CYLINDER HEAD ><2-7 <-- 916/0401 --> 916/0700 <-- 916/3001 --> 916/4059 <-- 916/4061 --> 916/4150
	72426461	3	CYLINDER HEAD ><2-7 <-- 916/4060 --> 916/4060 <-- 916/4151
2	72310651	6	VALVE GUIDE INTAKE 16,00MM
	72310652	6	VALVE GUIDE INTAKE 16,25MM
3	72310653	6	VALVE GUIDE OUTLET 16,00MM
	72310654	6	VALVE GUIDE OUTLET 16,25MM
4	72417068	6	VALVE SEAT RING INTAKE <-- 916/0401 --> 916/0700 <-- 916/3001 --> 916/4059 <-- 916/4061 --> 916/4150
	72426462	6	VALVE SEAT RING INTAKE <-- 916/4060 --> 916/4060 <-- 916/4151
	72492241	6	VALVE SEAT RING INTAKE REPAIR STEP <-- 916/0401 --> 916/0700 <-- 916/3001 --> 916/4059 <-- 916/4061 --> 916/4150
5	72315034	6	VALVE SEAT RING OUTLET 44,10MM
6	72311428	3	COVER
7	72311429	9	COVER
8	72312241	3	CYLINDER HEAD GASKET <>
	72426464	8	HEX BOLT, WITH COLLAR
9	72426464	24	HEX BOLT, WITH COLLAR MUST NOT BE RETIGHTENED SCREWS-TO BE USED ONCE ONLY
11	72417070	3	CYLINDER HEAD COVER
12	72317854	3	SEAL
13	72417071	17	TORX SCREW M6X35
	72416968	1	TORX SCREW M6X40
19	72312366	3	SEAL KIT <>
	72426464	8	HEX BOLT, WITH COLLAR
20	72423094	1	MARKING PLATE



Item	Part Number	Qty	Description Comments	Technical Specification
1	72417072	1	BREATHER MANIFOLD	
2	72417073	3	BANJO BOLT	
4	72417074	6	SEALING WASHER	
5	72417075	1	THREADED STUD	
6	72622285	1	SEALING WASHER	
7	72417076	1	BREATHER LINE ><8	
8	72346330	1	FASTENING COLLAR	
9	72315651	1	HEXAGONAL HEAD BOLT	DIN 933 M8X22-8.8A3L
10	72311788	1	DISC	DIN 125-8,4-ST.A3L
11	72317038	1	CONTROL VALVE	
12	72313642	1	MOLDED PIECE	
13	72611218	2	CLIP	
14	72417078	1	HOSE PIECE	
15	72316562	1	CLIP	
16	72611218	1	CLIP	
17	72342712	1	HOSE BARB	
18	72417109	1	SEALING WASHER	
19	72417079	1	ADAPTER NIPPLE	
20	72622285	1	SEALING WASHER	
21	72417080	1	OIL RETURN LINE	
22	72423359	1	GASKETS	
23	72417081	1	OIL RETURN LINE	
24	72312631	1	HOSE	
25	72611218	2	CLIP	

FAVORIT 916 (916/00401-01000 & 03001-06000)  
35984

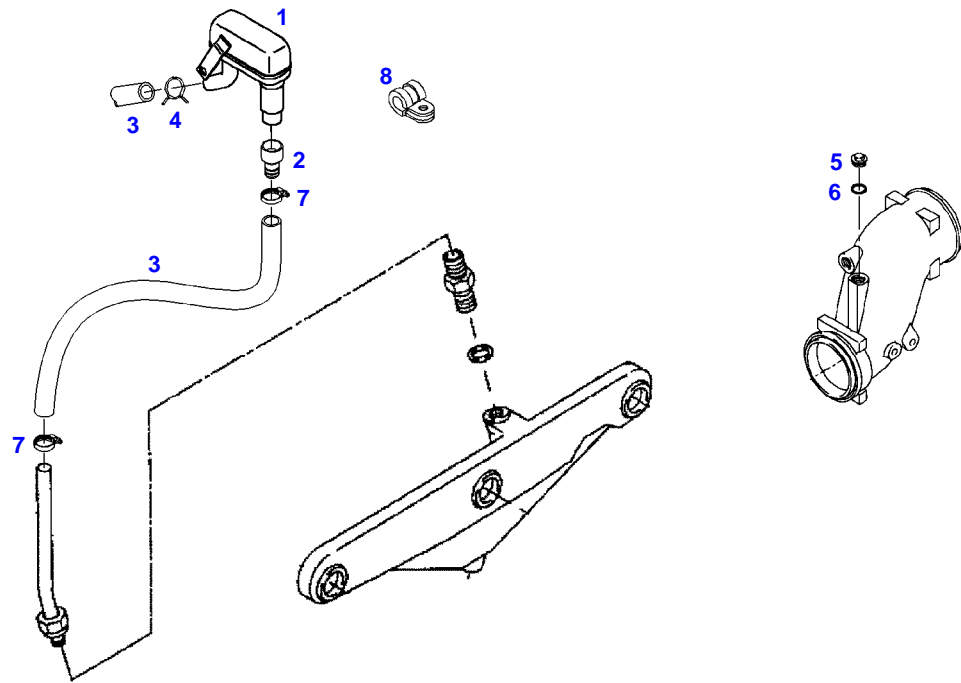

035984

Item	Part Number	Qty	Description Comments	Technical Specification
			<b>CHANGE TO OPEN CRANKCASE VENTILATION</b>	
1	72451208	1	BLEEDER VALVE	
2	72454834	1	REDUCER	
3	72451209	2	HOSE	
4	72431275	1	CLAMP	
5	72373973	1	DRAIN PLUG	DIN 910 M18X1,5-ST
6	72315099	1	SEALING WASHER	DIN 7603 A18X22-CU
7	72311166	2	HOSE CLIP	
8	72373549	1	PIPE CLAMP	

FAVORIT 916 (916/00401-01000 & 03001-06000)  
40535

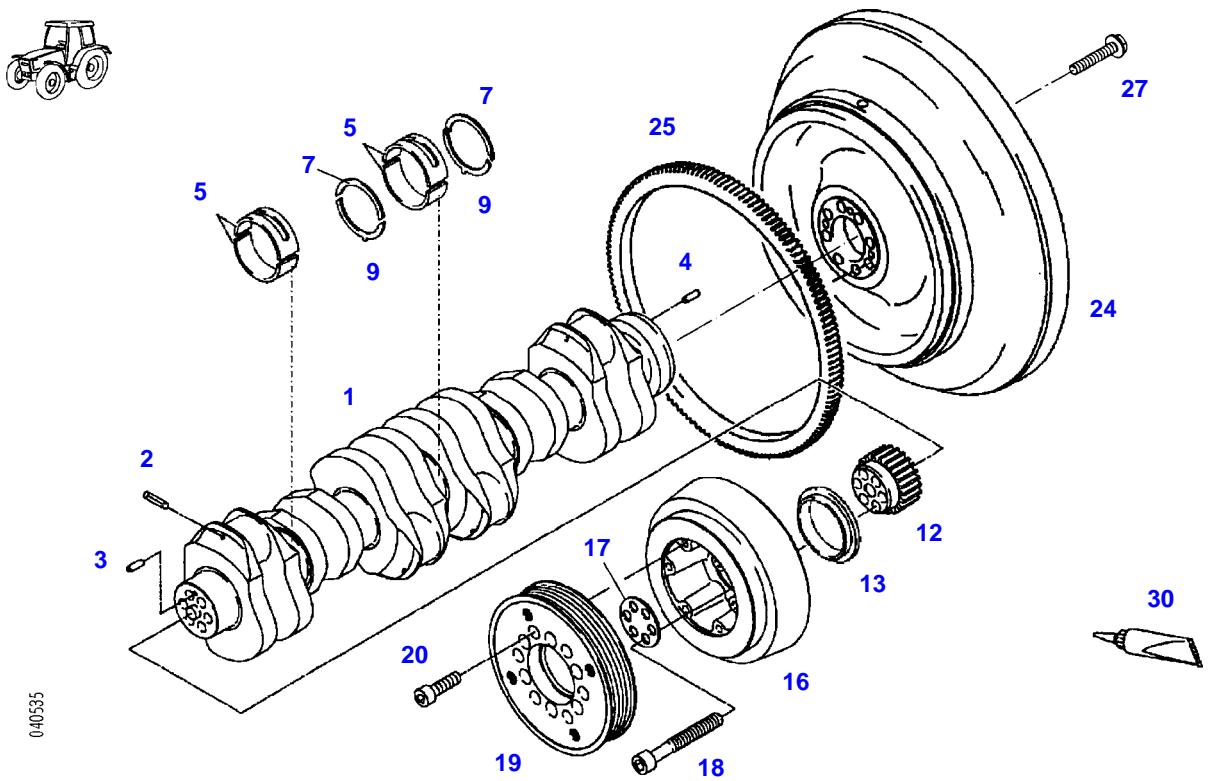

Item	Part Number	Qty	Description Comments	Technical Specification
1	72417087	1	CRANKSHAFT	
2	72417088	6	SEALING PLUG	
3	72313817	1	TENSIONING PIN	ISO8752-6X16-A-ST-ZNPHR10F-KOE
4	72313849	1	TENSIONING PIN	ISO8750-8X24-ST
5	72417089	7	MAIN BEARING	
	72417090	7	MAIN BEARING REPAIR STEP	
7	72417091	2	THRUST WASHER	
	72417092	2	THRUST WASHER REPAIR STEP	
9	72417093	2	THRUST WASHER	
	72417094	2	THRUST WASHER REPAIR STEP	
12	72316540	1	CRANKSHAFT GEAR	
13	72315016	1	SPRAYER RING	
16	72311632	1	VIBRATION DAMPER	
17	72311934	1	DISC	
18	72315396	6	SOCKET HEAD BOLT	M14X1,5X105-12.9-PHR
19	72419905	1	BELT PULLEY	
20	72315497	6	SOCKET HEAD BOLT	DIN 912 M10X35-10.9
24	72417095	1	FLYWHEEL ><25	
25	72312391	1	RING GEAR	
27	72315372	8	HEX BOLT, WITH COLLAR	
30	72311272	1	SEALING COMPOUND	

FAVORIT 916 (916/00401-01000 & 03001-06000)  
8735

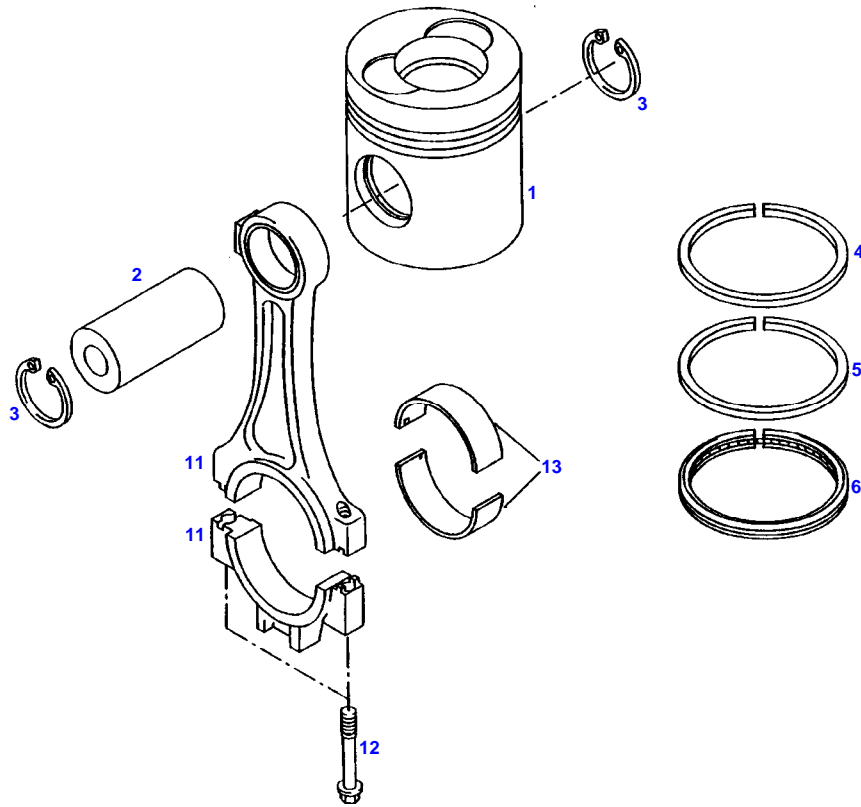

8735

Item	Part Number	Qty	Description Comments	Technical Specification
1	72417096	6	PISTON ><2-6 <-- 916/0401 --> 916/0700 <-- 916/3001 --> 916/4059 <-- 916/4061 --> 916/4150 <-- F926.202.310.320	
	72426465	6	PISTON ><2-6 <-- 916/4060 --> 916/4060 <-- 916/4151	
2			NOT AVAILABLE IN SINGLE PARTS	
3	72311096	12	LOCK WASHER	DIN 472-42X1,75
4	72417097	6	KEYSTONE RING	
5	72317292	6	TAPERED COMPRESSION RING	
6	72315017	6	WEDGE-SECTION RING S=4MM <-- 916/0401 --> 916/0700 <-- 916/3001 --> 916/4059 <-- 916/4061 --> 916/4150	
	72426466	6	WEDGE-SECTION RING S=3MM <-- 916/4060 --> 916/4060 <-- 916/4151	
11	72428723	6	PISTON ROD ><12	
12	72417099	12	WASHER HEAD BOLT REPLACE SCREWS SETWISE SCREWS-TO BE USED ONCE ONLY	
13	72417100	6	CONNECTING ROD BEARING	
	72417101	6	CONNECTING ROD BEARING REPAIR STEP 69,90MM	

FAVORIT 916 (916/00401-01000 & 03001-06000)  
10151

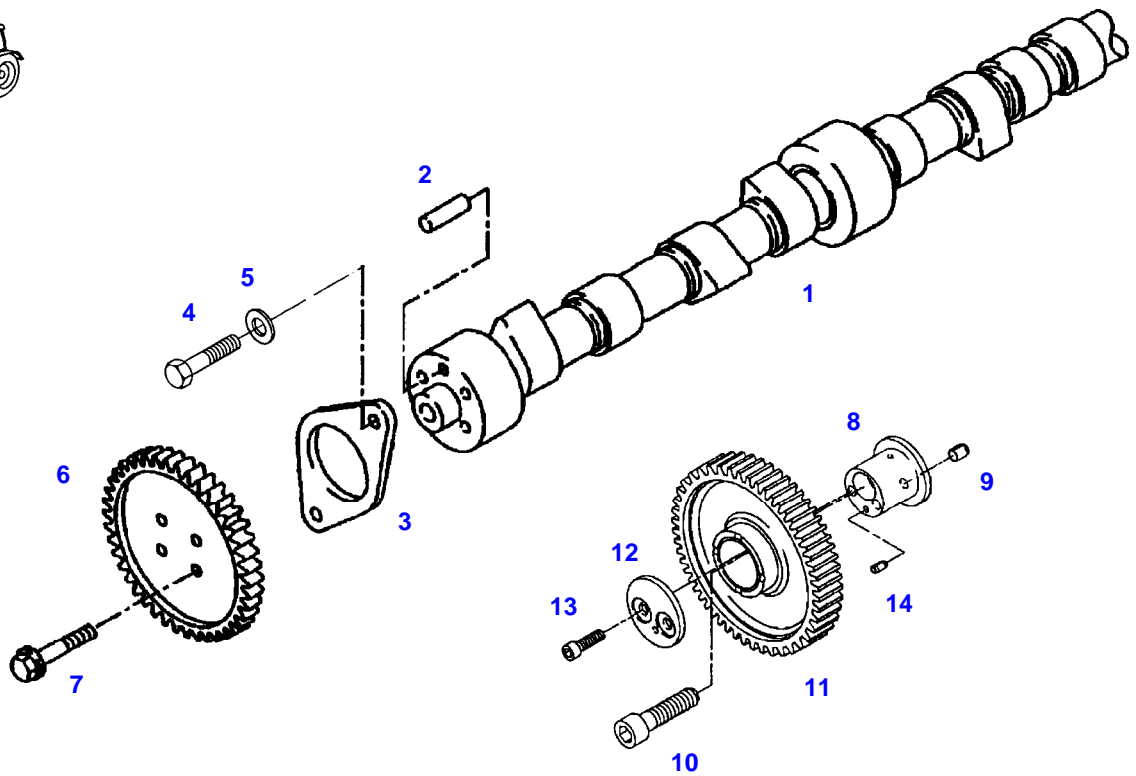

010151

Item	Part Number	Qty	Description Comments	Technical Specification
1	72417110	1	CAMSHAFT <-- 916/0401 --> 916/0700 <-- 916/3001 --> 916/4059 <-- 916/4061 --> 916/4150	
	72426468	1	CAMSHAFT ><2 <-- 916/4060 --> 916/4060 <-- 916/4151	
2	72313859	1	CYLINDER PIN	DIN 7-8M6X18-ST50K
3	72312126	1	FLANGE	
4	72315642	1	HEXAGONAL HEAD BOLT	DIN 933 M8 X 16-8.8A3L
5	72311788	1	DISC	DIN 125-8,4-ST.A3L
6	72416958	1	CAM WHEEL	
7	72315385	4	HEX BOLT, WITH COLLAR	
8	72310408	1	BOLT ><9,14	
9	72313847	1	TENSIONING PIN	ISO8750-8X10-ST
10	72315373	1	SOCKET HEAD BOLT	
11	72317157	1	INTERMEDIATE GEAR	
12	72317117	1	THRUST WASHER	
13	72315776	2	SOCKET HEAD BOLT	DIN 6912 M8X30-8.8
14	72313846	1	TENSIONING PIN	ISO8750-5X10-ST

FAVORIT 916 (916/00401-01000 & 03001-06000)  
10157

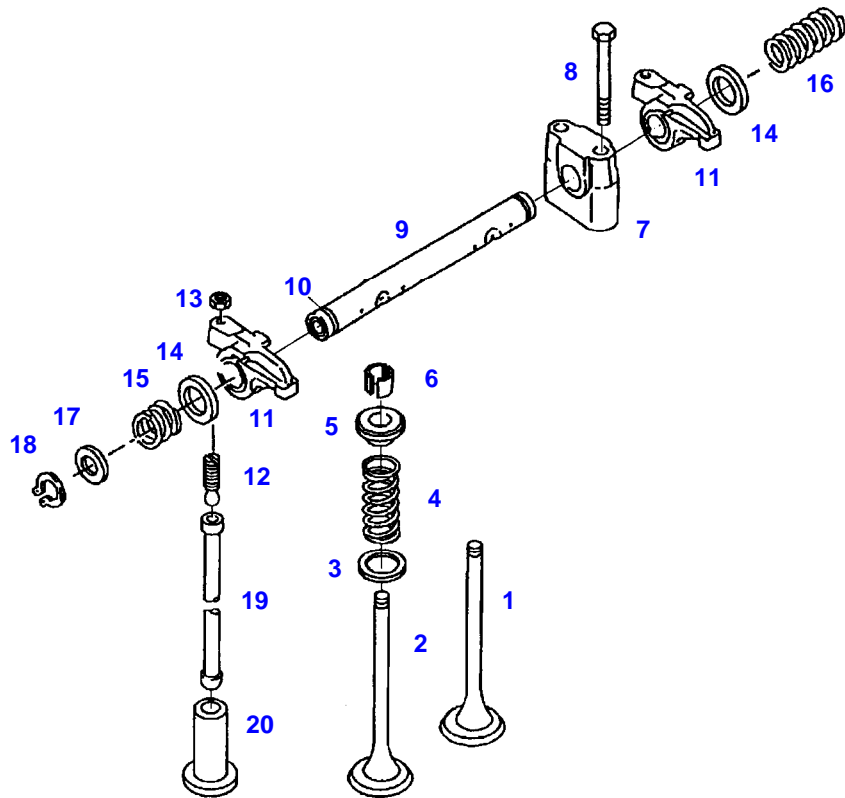

010157

Item	Part Number	Qty	Description Comments	Technical Specification
1	72317040	6	INTAKE VALVE	
2	72317039	6	OUTLET VALVE	
3	72311770	12	DISC	
4	72426516	12	VALVE SPRING	
5	72314931	12	VALVE SPRING RETAINER	
6	72311279	24	VALVE SPRING KEY	
7	72310123	6	ROCKER ARM SUPPORT	
8	72310402	12	TORX SCREW	
			REPLACE SCREWS SETWISE	
9	72310120	3	ROCKER SHAFT	
			><10	
10	72314700	6	PLUG	
11	72604686	12	ROCKER ARM	
12	72315386	12	PRESSURE SCREW	
13	72313252	12	NUT	
14	72311769	12	DISC	
15	72316451	6	COMPRESSION SPRING	
16	72316450	3	COMPRESSION SPRING	
17	72317112	6	MACHINE WASHER	
18	72311061	6	LOCK WASHER	DIN 471-20X1,2
19	72316921	12	PUSH ROD	
20	72316919	12	VALVE TAPPET	
			20,00MM	

FAVORIT 916 (916/00401-01000 & 03001-06000)  
32008

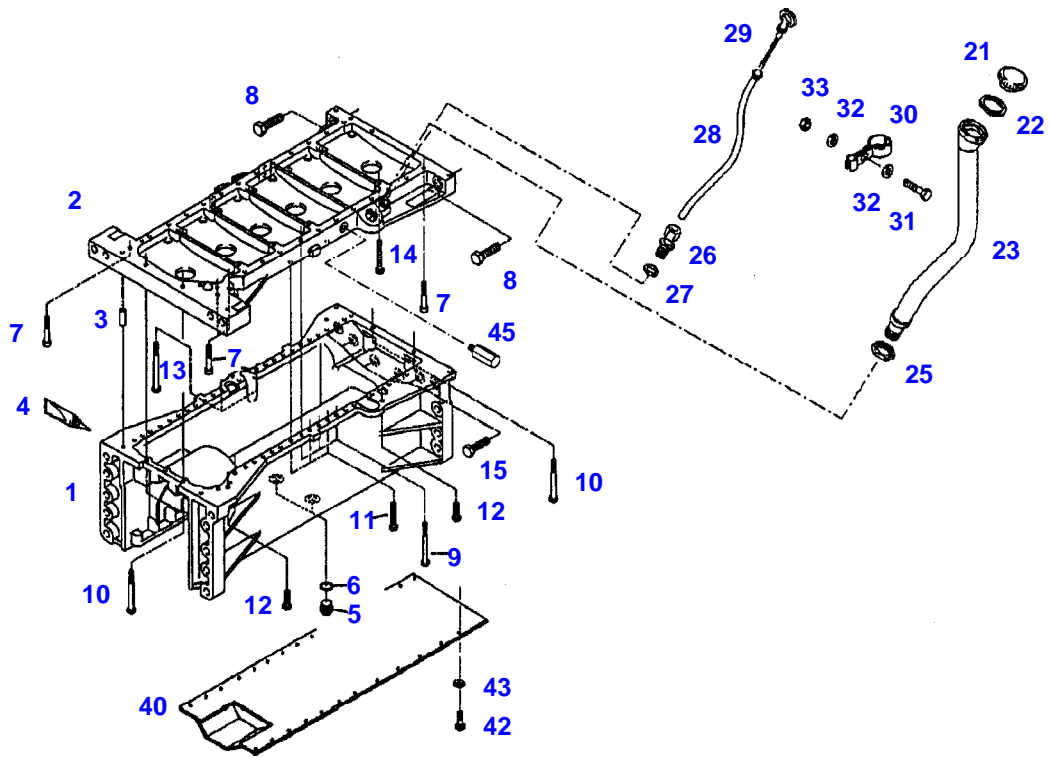

032008

Item	Part Number	Qty	Description Comments	Technical Specification
1	72417112	1	OIL PAN ><2+3	
2			NOT AVAILABLE IN SINGLE PARTS	
3	72313723	2	CENTERING PIN	
4	72602309	1	SEALING COMPOUND	
5	72315802	2	SCREW	DIN 7604 AM22X1,5-ST
6	72622285	2	SEALING WASHER	
7	72315480	5	SOCKET HEAD BOLT	DIN 912-M8X50-10.9-ZNPHR3F
8	72315597	2	HEXAGONAL HEAD BOLT	DIN 931-M18X65-10.9-ZNPHR3F
9	72315538	21	HEXAGONAL HEAD BOLT	DIN 931-M8X80-10.9-ZNPHR3F
10	72315538	4	HEXAGONAL HEAD BOLT	DIN 931-M8X80-10.9-ZNPHR3F
11	72315666	21	HEXAGONAL HEAD BOLT	DIN 933 M8X50-10.9 ZNPHR3F
12	72315656	3	HEXAGONAL HEAD BOLT	DIN 933-M8X30-10.9
13	72315540	2	HEXAGONAL HEAD BOLT	DIN 931 M8X100-10.9
14	72374161	8	HEXAGONAL HEAD BOLT	DIN 931 M8X60 GWA-10.9
15	72315739	6	HEXAGONAL HEAD BOLT	DIN 933 M16X60 GWA-10.9
21	72311395	1	COVER	
22	72312231	1	SEAL	
23	72316293	1	OIL FILLER NECK	
25	72313251	1	NUT	
26	72311313	1	STRAIGHT THREADED CONNECTION	DIN 2353-CL10-A-ST
27	72422299	1	SEALING WASHER	
28	72316957	1	GUIDE TUBE	
29	72311667	1	DIPSTICK	
30	72311224	2	PIPE CLAMP	
31	72315660	1	HEXAGONAL HEAD BOLT	DIN 933 M8X35-8.8A3L
32	72311788	2	DISC	DIN 125-8,4-ST.A3L
33	72313268	1	NUT	DIN 934 M8-8A3L
40	72418244	1	COVER PLATE	
42	72315688	25	HEXAGONAL HEAD BOLT	M10 X 35 CL10.9
43	72315054	25	SPLIT WASHER	FWN 65208-10-A3L
45	72313922	1	STUD BOLT	

FAVORIT 916 (916/00401-01000 & 03001-06000)  
40538

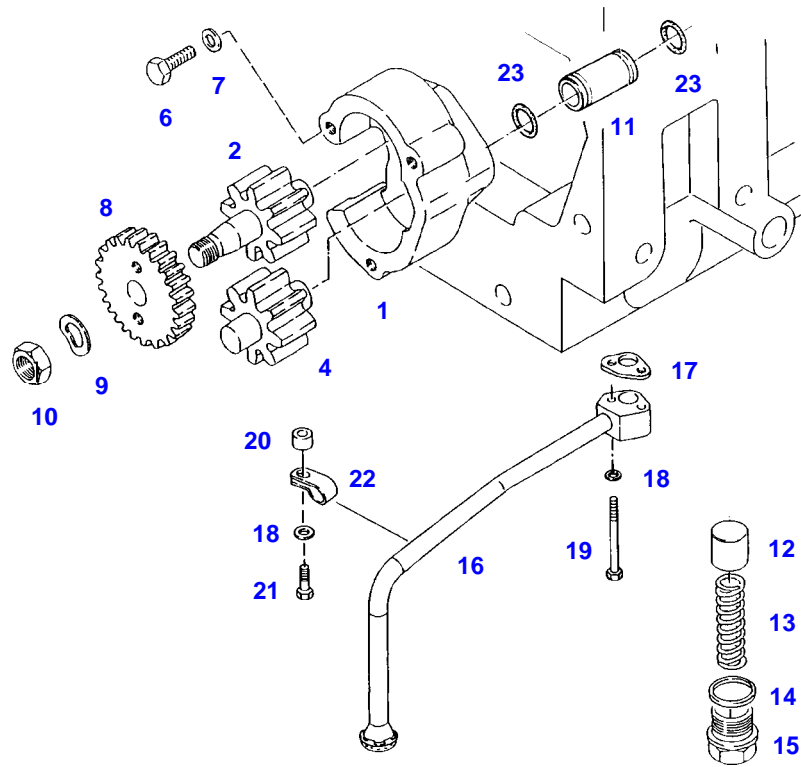

040538

Item	Part Number	Qty	Description Comments	Technical Specification
1	72312754	1	PUMP HOUSING	
2	72609443	1	OIL IMPELLER	
	72608305	1	OIL IMPELLER	
4	72608305	1	OIL IMPELLER	
	72609443	1	OIL IMPELLER	
6	72315649	3	HEXAGONAL HEAD BOLT	DIN 933 M8X20-10.9
7	72311788	3	DISC	DIN 125-8,4-ST.A3L
8	72317160	1	DRIVE GEAR	
9	72317123	1	SPRING WASHER	DIN 137 B12-ZNPHR
10	72372881	1	NUT	DIN 936 M12X1,5-17H A3L
11	72316956	1	JOINT TUBE	
12	72314366	1	PISTON	
13	72316448	1	COMPRESSION SPRING	
14	72423359	1	GASKETS	
15	72315382	1	SCREW	
16	72417104	1	OIL SUCTION LINE	
			><22	
17	72312262	1	SEAL	
18	72311788	3	DISC	DIN 125-8,4-ST.A3L
19	72315541	2	HEXAGONAL HEAD BOLT	DIN 931 M8X100-8.8
20	72310665	1	DISTANCE BUSHING	
21	72315653	1	HEXAGONAL HEAD BOLT	DIN 933 M8 X 25-8.8A3L
22			NOT AVAILABLE IN SINGLE PARTS	
23	72313529	2	SEAL	

FAVORIT 916 (916/00401-01000 & 03001-06000)  
F51387

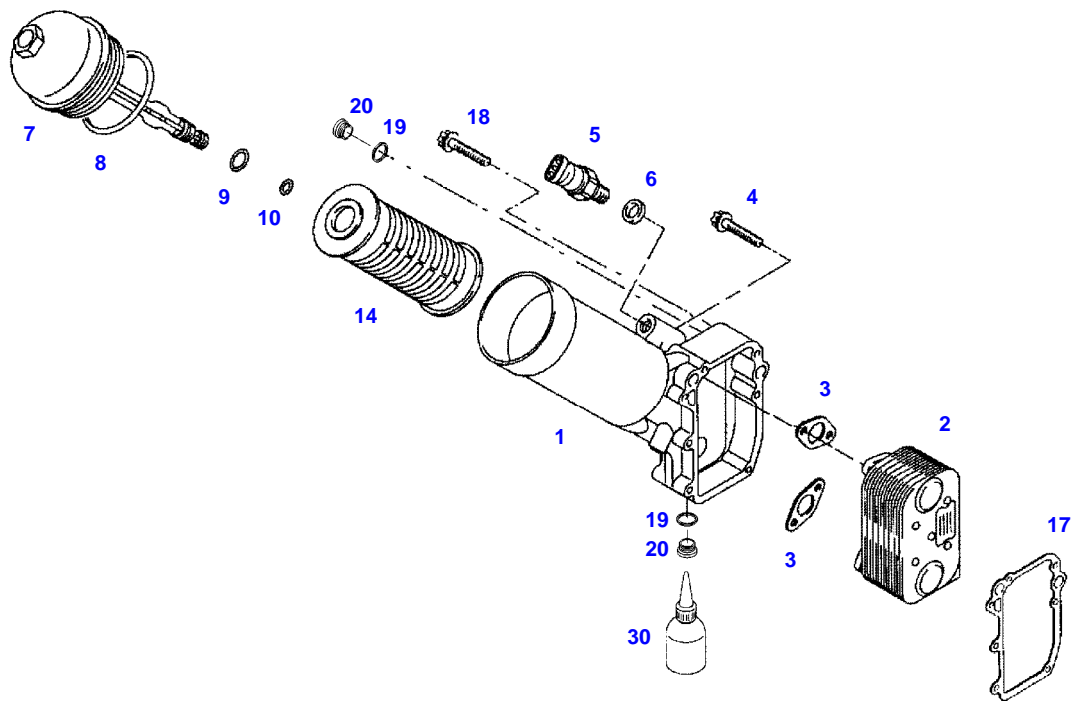

051387



Item	Part Number	Qty	Description Comments	Technical Specification
1	72426473	1	OIL FILTER HEAD ><2-10	
2	72311378	1	OIL COOLER	
3	72312256	2	SEAL	
4	72423410	4	WASHER HEAD BOLT	
5			SEE ELECTRICAL SYSTEM TRANSMITTER	
6	72422299	1	SEALING WASHER	
7	72417084	1	COVER ><8-10	
8	72318003	1	SEAL	
9	72417085	1	SEAL 6X2	
10	72417086	1	SEAL 10X2	
14	72317863	1	OIL FILTER	
17	72417107	1	SEAL	
18	72455491	7	HEXAGONAL HEAD BOLT	
19	72417109	2	SEALING WASHER	
20	72315440	2	PLUG SCREW	DIN 908 M18 X 1,5-ST
	72482917	2	THREADED BUSHING WITHOUT PICTURE NO. 21	
30	72313159	1	ADHESIVE FOR POSITION 21	LOCTITE 648 50ML

FAVORIT 916 (916/00401-01000 & 03001-06000)  
40564

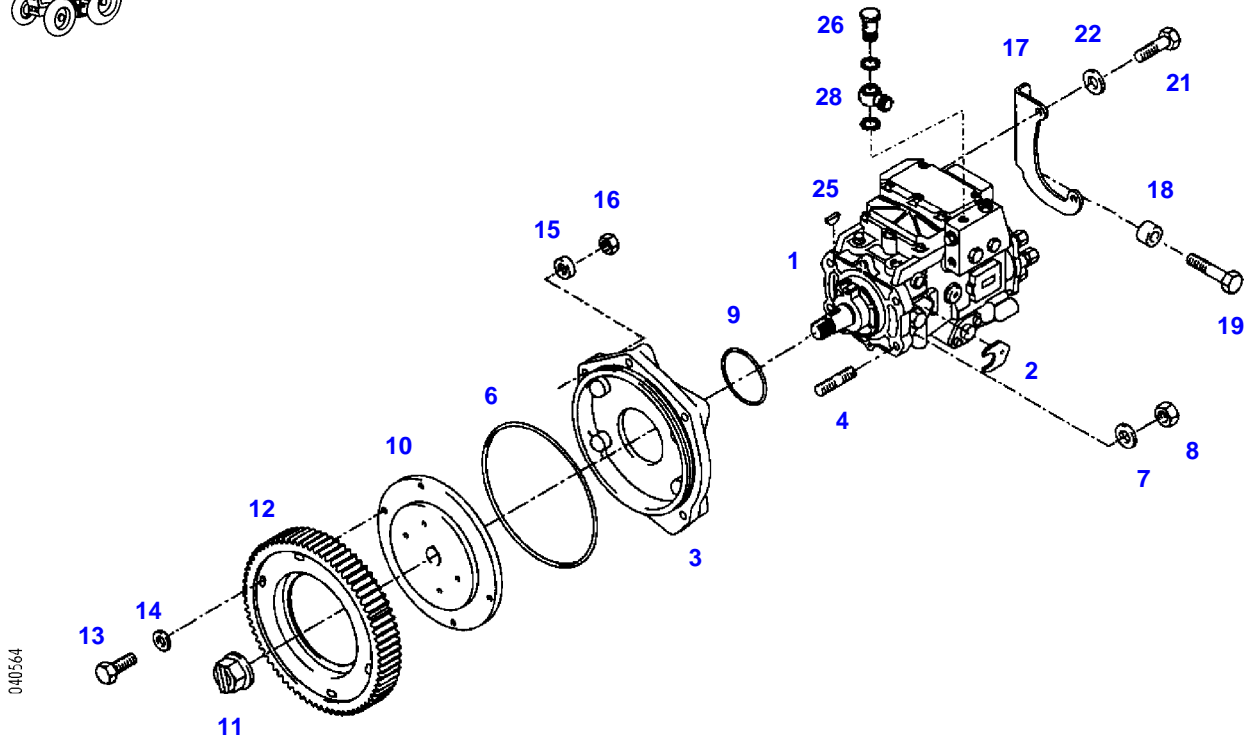

040564



**Suggest:**

**For more complete manuals. Please go to the home page.**

**<https://www.ebooklibonline.com>**

**If the above button click is invalid. Please download this document first, and then click the above link to download the complete manual.**

**Thank you so much for reading**

Item	Part Number	Qty	Description Comments	Technical Specification
			<-- 916/0401 --> 916/0700 <-- 916/3001 --> 916/4059 <-- 916/4061 --> 916/4150	
1	72317933	1	INJECTION PUMP ><25	
2	72417117	1	SPACER	
3	72417118	1	MOUNTING FLANGE ><4	
4	72415291	4	STUD BOLT	
6	72313510	1	O-RING	140X4-NBR 70 FWN56402
7	72311789	4	DISC	DIN 125-10,5-ST.A3L
8	72313271	4	NUT	DIN 934 M10-8
9	72313536	1	SEAL	
10	72417120	1	HUB	
11	72417121	1	NUT	
12	72417122	1	DRIVE GEAR	
13	72315656	4	HEXAGONAL HEAD BOLT	DIN 933-M8X30-10.9
14	72311762	4	WASHER	
15	72311789	4	DISC	DIN 125-10,5-ST.A3L
16	72313271	4	NUT	DIN 934 M10-8
17	72422178	1	RETAINER	
18	72425791	1	SPACER BUSHING <>	
	72315666	1	HEXAGONAL HEAD BOLT	DIN 933 M8X50-10.9 ZNPHR3F
19	72315666	1	HEXAGONAL HEAD BOLT	DIN 933 M8X50-10.9 ZNPHR3F
	72315658	1	HEXAGONAL HEAD BOLT	DIN 933 M8X35-10.9
21	72315651	2	HEXAGONAL HEAD BOLT	DIN 933 M8X22-8.8A3L
22	72311773	2	DISC	
25	72316454	1	WOODRUFF KEY	DIN 6888-4X6,5-ST60
26			SEE FUEL PUMP FUEL LINES	
28			SEE FUEL PUMP FUEL LINES	

FAVORIT 916 (916/00401-01000 & 03001-06000)  
33200

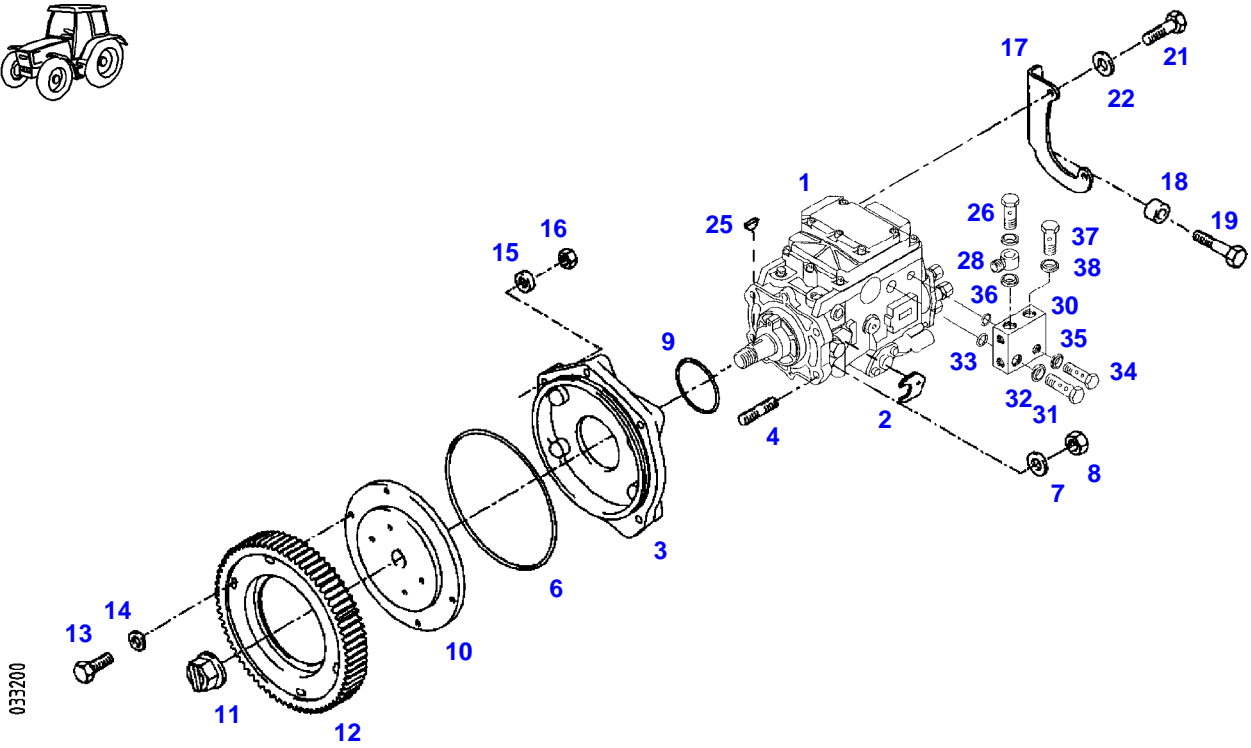

**<https://www.ebooklibonline.com>**

Hello dear friend!

Thank you very much for reading.

Enter the link into your browser.

The full manual is available for immediate download.

**<https://www.ebooklibonline.com>**