

| Page Number | Page Title | Page Reference |
|--------------------|-------------------------------------|-----------------------|
| 01-000-TOC | ENGINE, FUEL AND EXHAUST SYSTEM | 01-000-TOC |
| 02-000-TOC | AXLES | 02-000-TOC |
| 03-000-TOC | STEERING SYSTEM | 03-000-TOC |
| 04-000-TOC | DRIVE TRAIN SYSTEM | 04-000-TOC |
| 05-000-TOC | COMPRESSED AIR SYSTEM | 05-000-TOC |
| 06-000-TOC | HYDRAULIC SYSTEM | 06-000-TOC |
| 07-000-TOC | ELECTRICAL SYSTEM | 07-000-TOC |
| 08-000-TOC | CAB | 08-000-TOC |
| 09-000-TOC | AIR CONDITIONING AND HEATING SYSTEM | 09-000-TOC |
| 10-000-TOC | CHASSIS | 10-000-TOC |
| 11-000-TOC | WHEELS | 11-000-TOC |
| 12-000-TOC | IMPLEMENT LIFT SYSTEM FRONT | 12-000-TOC |
| 13-000-TOC | IMPLEMENT LIFT SYSTEM REAR | 13-000-TOC |
| 14-000-TOC | FRONT/REAR LOADERS | 14-000-TOC |
| 15-000-TOC | ACCESSORIES | 15-000-TOC |

FAVORIT 714NA (714/00101-00200 & 01001-08000)
31887

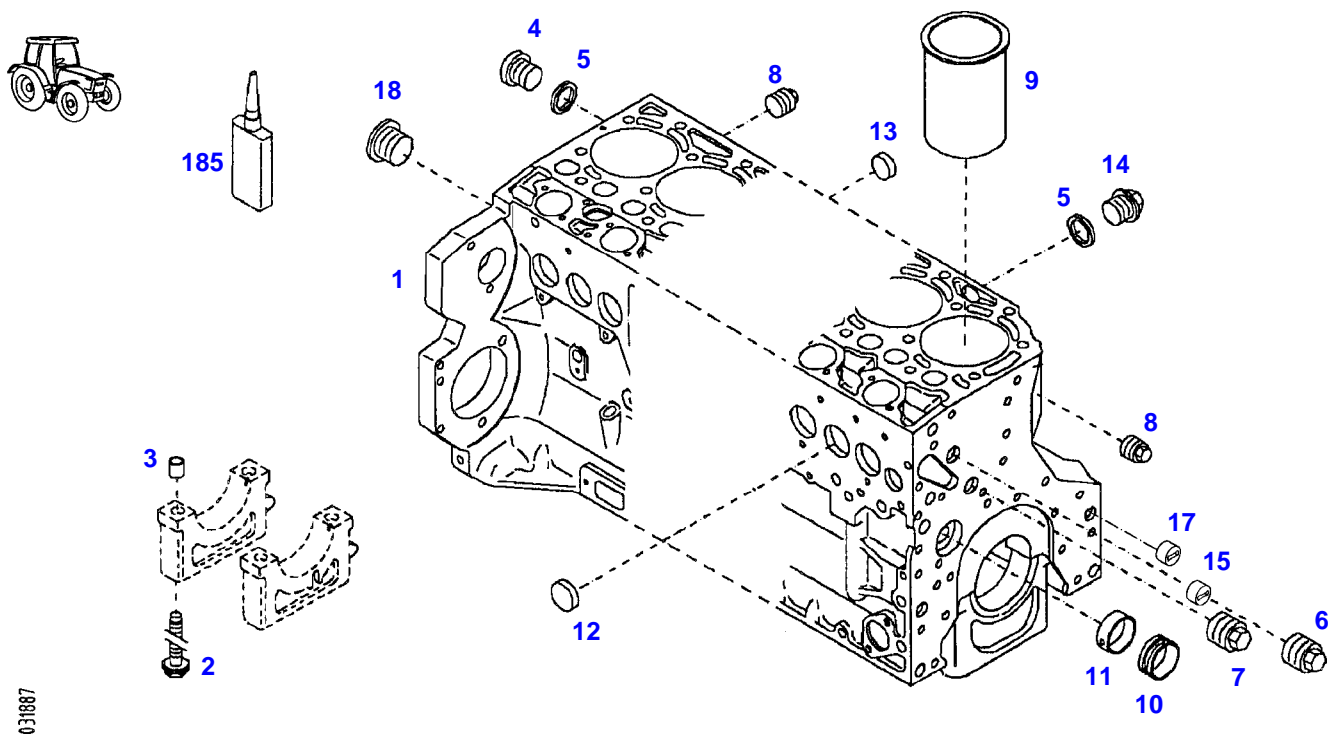

031887

| Item | Part Number | Qty | Description Comments | Technical Specification |
|------|-------------|-----|--|--------------------------|
| | 72415426 | 1 | ENGINE ENGINE NEW <-- 714/0101 --> 714/0200 <-- 714/1001 --> 714/5621 <-- Z714.201.010.020 | BF06M2013C |
| | 72604785 | 1 | ENGINE EXCHANGE REMANUFACTURED SHORT BLOCK ENGINE <-- 714/0101 --> 714/0200 <-- 714/1001 --> 714/5621 | |
| | 72426511 | 1 | ENGINE ENGINE NEW <-- 714/5622 <-- Z714.201.010.030 | BF06M2013C |
| | 72604785 | 1 | ENGINE EXCHANGE REMANUFACTURED SHORT BLOCK ENGINE <-- 714/5622 | |
| 1 | 72423957 | 1 | CRANKCASE ><2-15,17,18 ENG.NO. --> 773570 <-- F718.202.210.210 ENG.NO. --> 601800 <> <> | |
| | 72423960 | 1 | THRUST WASHER | |
| | 72429392 | 1 | CRANKCASE ><2-15,17,18 ENG.NO. <-- 773571 <-- F718.202.210.210 | |
| 2 | 72416467 | 14 | HEXAGONAL HEAD BOLT | |
| 3 | 72344342 | 14 | ADAPTER BUSH | |
| 4 | 72315438 | 1 | PLUG SCREW | DIN 908 M14X1,5-ST |
| 5 | 72315095 | 3 | SEALING WASHER | DIN 7603 A14X20-CU |
| 6 | 72325319 | 1 | PLUG M30X1,5 | |
| 7 | 72325321 | 1 | PLUG | |
| 8 | 72325322 | 2 | PLUG M14X1,5 ENG.NO. --> 773570 | |
| | 72429347 | 2 | SCREW M14X1,5 ENG.NO. <-- 773571 | M14X1,5 |
| 9 | 72416468 | 6 | CYLINDER LINER | |
| 10 | 72416469 | 6 | BEARING BUSHING | |
| 11 | 72416470 | 1 | BEARING BUSHING | |
| 12 | 72325325 | 9 | CORE HOLE PLUG | |
| 13 | 72325326 | 6 | CORE HOLE PLUG | |
| 14 | 72315799 | 2 | PLUG | DIN 7604 AM14X1,5-A3L |
| 15 | 72325327 | 1 | GUIDE SLEEVE | |
| 17 | 72415819 | 1 | GUIDE SLEEVE ENG.NO. <-- 601801 | |
| 18 | 72416465 | 1 | PLUG M22X1,5 ENG.NO. --> 773570 | |
| | 72431135 | 1 | LOCKING PLUG M22X1,5 ENG.NO. <-- 773571 | |
| 185 | 72381391 | 1 | THREADLOCKER | LOCTITE 243 10ML |

<https://www.ebooklibonline.com>

Hello dear friend!

Thank you very much for reading.

Enter the link into your browser.

The full manual is available for immediate download.

<https://www.ebooklibonline.com>

FAVORIT 714NA (714/00101-00200 & 01001-08000)
432327-M-1



432327-M-1

| Item | Part Number | Qty | Description Comments | Technical Specification |
|-----------------------|-------------|-----|-------------------------|-------------------------|
| BLANKING PARTS | | | | |
| 1 | 72627515 | 1 | CORE HOLE PLUG | |
| 2 | 72315088 | 2 | SEALING WASHER | DIN 7603 A10X13,5-CU |
| 3 | 72323677 | 2 | PLUG | |
| 4 | 72631860 | 2 | SLUG | |
| 185 | 72325403 | 1 | SAFE.LOCK AGENT | |

FAVORIT 714NA (714/00101-00200 & 01001-08000)
30094

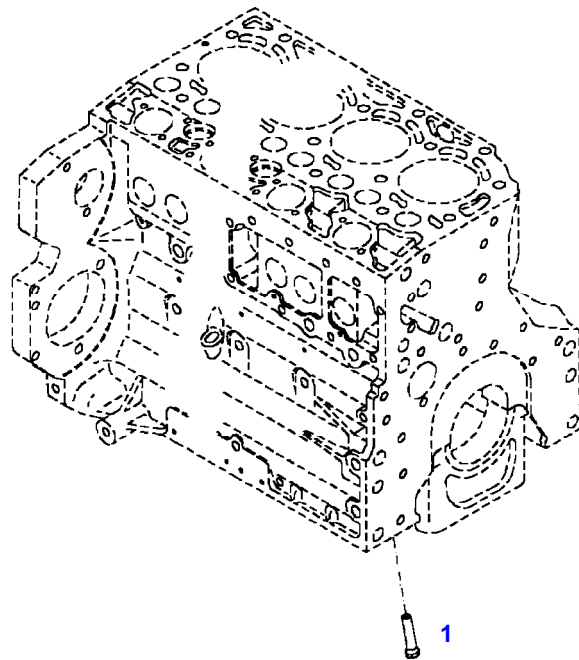

7600E0

Fendt

FAVORIT 714NA (714/00101-00200 & 01001-08000)

F714105

CRANKCASE

Page01-0003

| Item | Part Number | Qty | Description Comments |
|------|-------------|-----|-------------------------|
| | | | PISTON COOL.NOZZLE |
| 1 | 72415140 | 6 | PISTON COOLING JET |

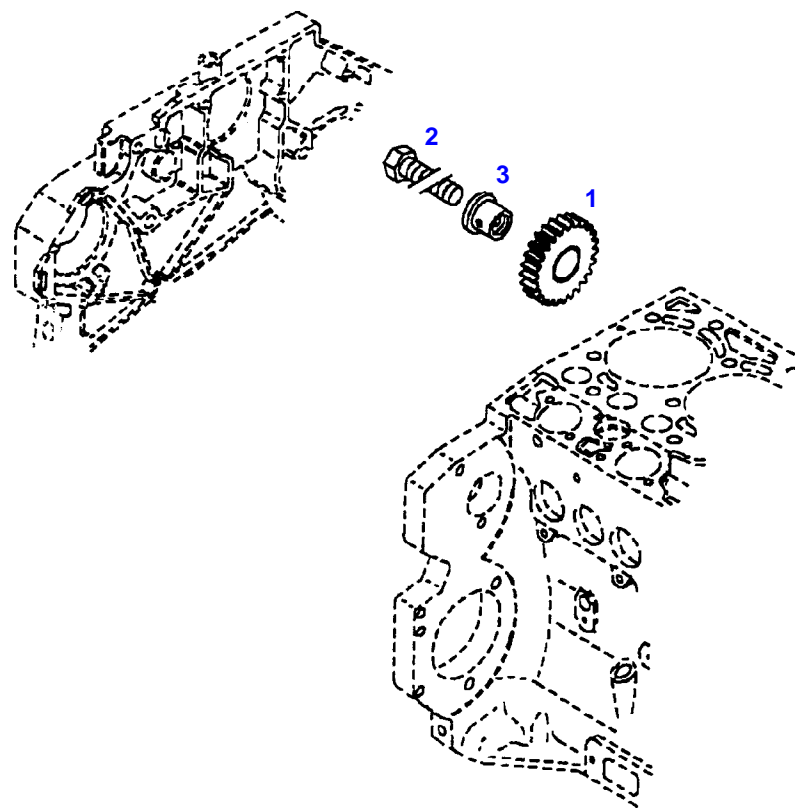

12057

| Item | Part Number | Qty | Description Comments | Technical Specification |
|------|-------------|-----|---------------------------|-------------------------|
| | | | INTERM. GEAR WHEEL | |
| 1 | 72325335 | 1 | GEAR WHEEL | |
| 2 | 72315658 | 1 | HEXAGONAL HEAD BOLT | DIN 933 M8X35-10.9 |
| 3 | 72325336 | 1 | PIVOT | |

FAVORIT 714NA (714/00101-00200 & 01001-08000)
40194

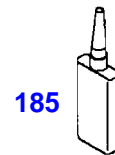
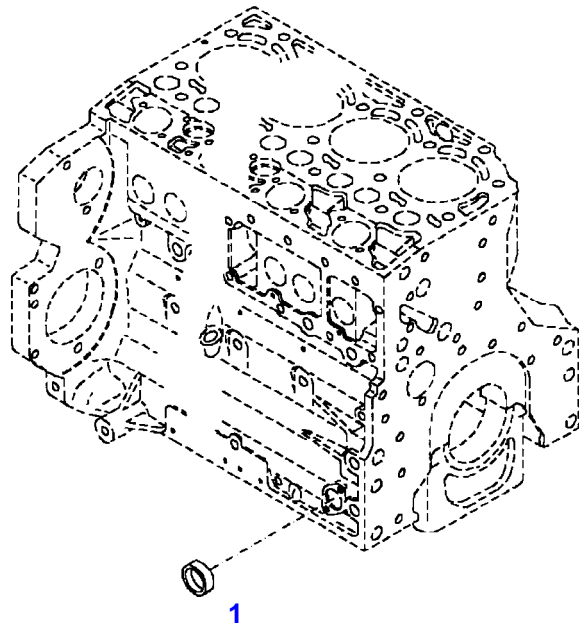

040194

Fendt

FAVORIT 714NA (714/00101-00200 & 01001-08000)

F714105

CRANKCASE

Page01-0005

| Item | Part Number | Qty | Description Comments |
|------|-------------|-----|-------------------------|
| | | | LOCKING PLUG |
| 1 | 72325326 | 1 | CORE HOLE PLUG |
| 185 | 72325403 | 1 | SAFE.LOCK AGENT |

FAVORIT 714NA (714/00101-00200 & 01001-08000)
30097

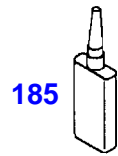
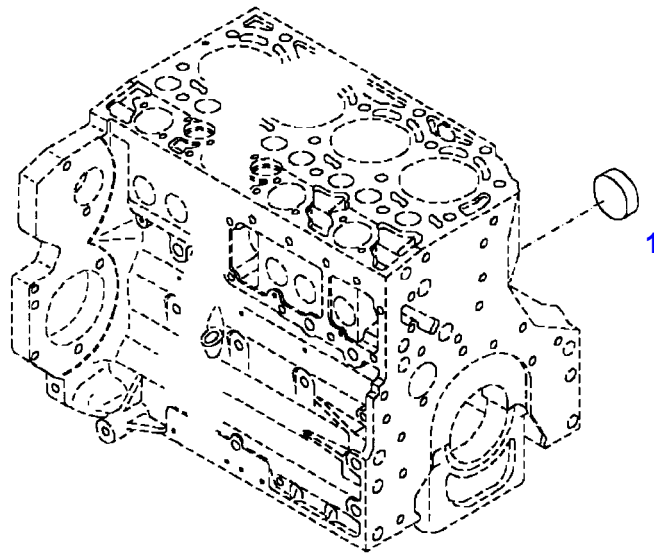

030097

Fendt

FAVORIT 714NA (714/00101-00200 & 01001-08000)

F714105

CRANKCASE

Page01-0006

| Item | Part Number | Qty | Description Comments |
|------|-------------|-----|--|
| | | | LOCKING PLUG <-- 714/0101 --> 714/0200 <-- 714/1001 --> 714/5621 |
| 1 | 72325337 | 1 | CORE HOLE PLUG |
| 185 | 72325403 | 1 | SAFE.LOCK AGENT |

FAVORIT 714NA (714/00101-00200 & 01001-08000)
F51551

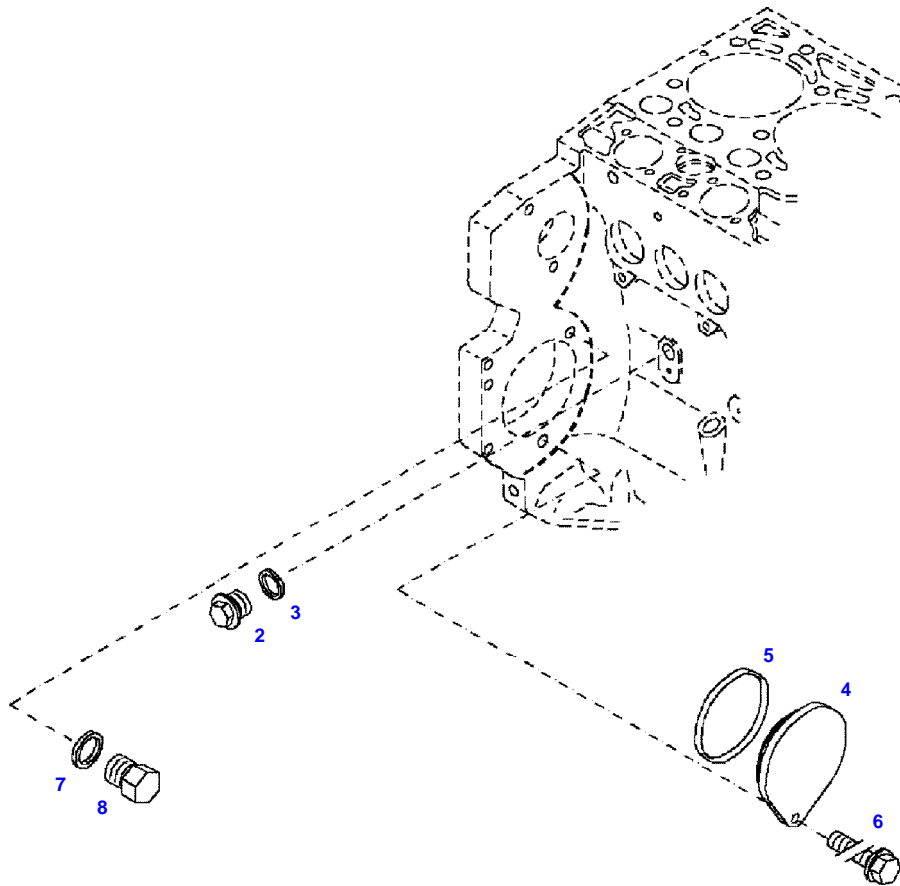

051551



| Item | Part Number | Qty | Description Comments | Technical Specification |
|------|-------------|-----|---|-------------------------|
| | | | BLANKING PARTS ENGINE NUMBER --> 829341 | |
| 2 | 72315799 | 1 | PLUG NOT NEEDED WITH AIR BRAKE | DIN 7604 AM14X1,5-A3L |
| 3 | 72315094 | 1 | SEALING WASHER NOT NEEDED WITH AIR BRAKE | DIN 7603 A14X18-CU |
| 4 | 72431648 | 1 | COVER NOT NEEDED WITH AIR BRAKE | |
| 5 | 72416472 | 1 | SEAL 96X4MM NOT NEEDED WITH AIR BRAKE | |
| 6 | 72621034 | 1 | HEXAGONAL HEAD BOLT NOT NEEDED WITH AIR BRAKE | M10X20 |
| 7 | 72315088 | 1 | SEALING WASHER | DIN 7603 A10X13,5-CU |
| 8 | 72323677 | 1 | PLUG | |

FAVORIT 714NA (714/00101-00200 & 01001-08000)
F51552

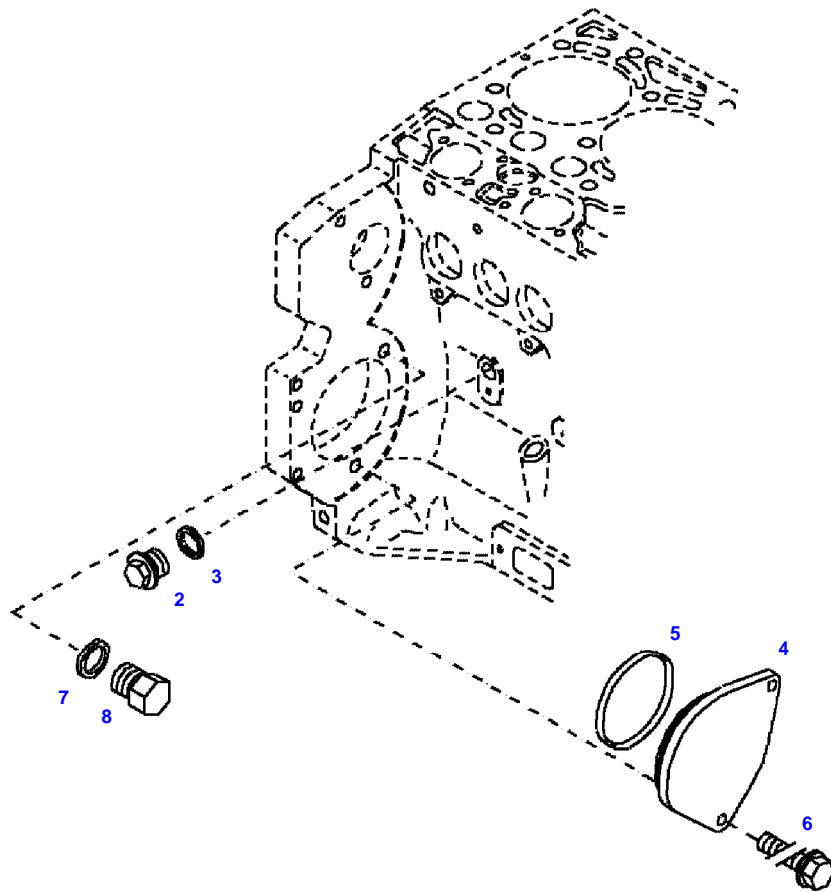

051552



| Item | Part Number | Qty | Description Comments | Technical Specification |
|------|-------------|-----|---|-------------------------|
| | | | BLANKING PARTS ENGINE NUMBER <-- 829342 | |
| 2 | 72315799 | 1 | PLUG NOT NEEDED WITH AIR BRAKE | DIN 7604 AM14X1,5-A3L |
| 3 | 72315094 | 1 | SEALING WASHER NOT NEEDED WITH AIR BRAKE | DIN 7603 A14X18-CU |
| 4 | 72431648 | 1 | COVER NOT NEEDED WITH AIR BRAKE | |
| 5 | 72416472 | 1 | SEAL 96X4MM NOT NEEDED WITH AIR BRAKE | |
| 6 | 72621034 | 2 | HEXAGONAL HEAD BOLT NOT NEEDED WITH AIR BRAKE | M10X20 |
| 7 | 72315088 | 1 | SEALING WASHER | DIN 7603 A10X13,5-CU |
| 8 | 72323677 | 1 | PLUG | |

FAVORIT 714NA (714/00101-00200 & 01001-08000)
40029

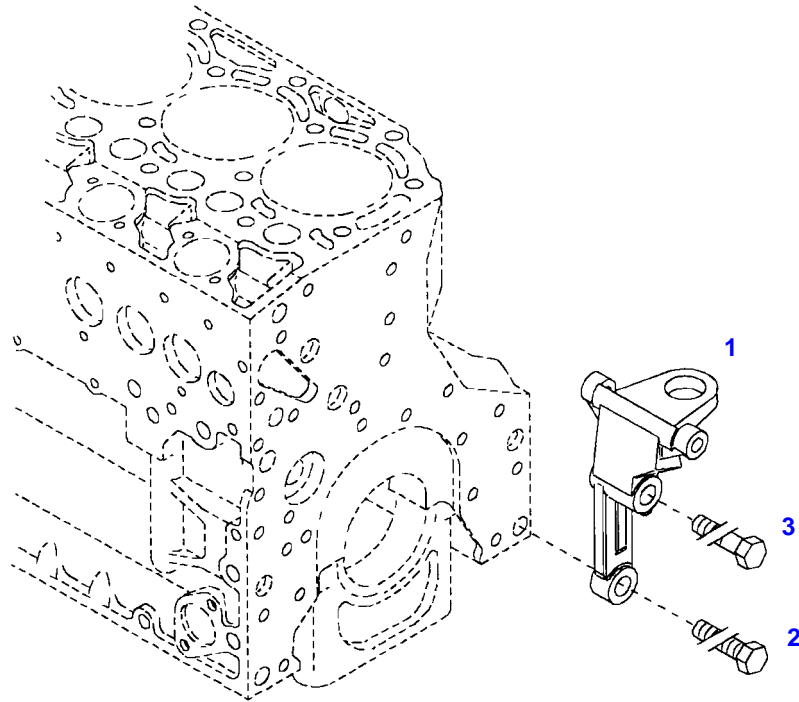

040029

| Item | Part Number | Qty | Description Comments | Technical Specification |
|------|-------------|-----|-------------------------|-------------------------|
| | | | LEFT | |
| 1 | 72428791 | 1 | ENGINE SUSPENSION | |
| 2 | 72418408 | 1 | HEXAGONAL HEAD BOLT | DIN 933 M16X40 GWA-10.9 |
| 3 | 72374294 | 1 | HEXAGONAL HEAD BOLT | DIN 931-M16X85 GWA-10.9 |

FAVORIT 714NA (714/00101-00200 & 01001-08000)
40030

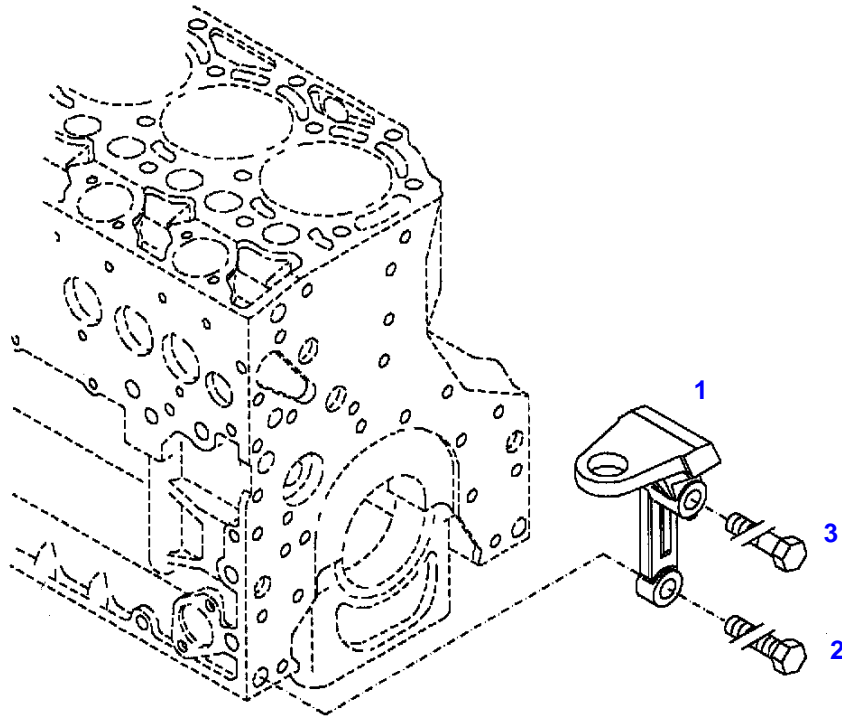

040030

| Item | Part Number | Qty | Description Comments | Technical Specification |
|------|-------------|-----|-------------------------|-------------------------|
| | | | RIGHT | |
| 1 | 72423955 | 1 | ENGINE SUSPENSION | |
| 2 | 72418408 | 1 | HEXAGONAL HEAD BOLT | DIN 933 M16X40 GWA-10.9 |
| 3 | 72374294 | 1 | HEXAGONAL HEAD BOLT | DIN 931-M16X85 GWA-10.9 |

FAVORIT 714NA (714/00101-00200 & 01001-08000)
35107

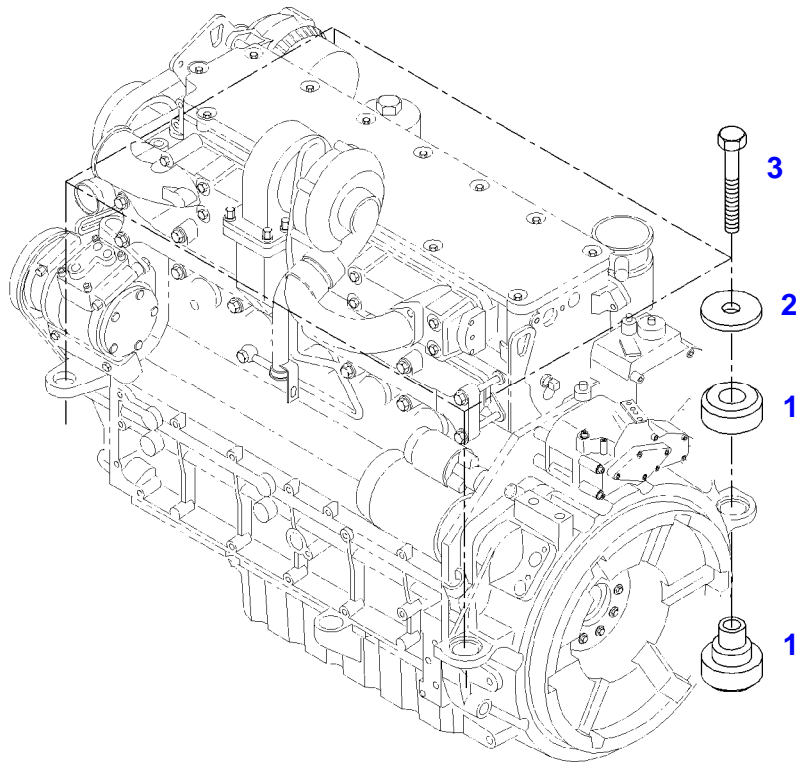

035107

Fendt

FAVORIT 714NA (714/00101-00200 & 01001-08000)

F714105

ENGINE BEARINGS

Page01-0011

| Item | Part Number | Qty | Description Comments | Technical Specification |
|------|-------------|-----|-------------------------|-------------------------|
| 1 | 72423991 | 4 | ENGINE MOUNT | |
| 2 | 72318110 | 4 | DISC | |
| 3 | 72315563 | 4 | HEXAGONAL HEAD BOLT | DIN 931 M12X80-8.8A3L |

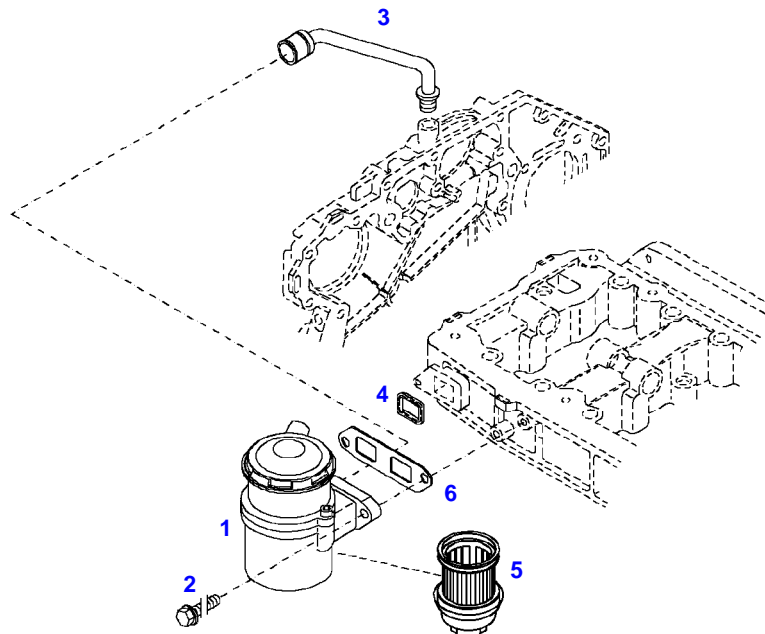

036448

| Item | Part Number | Qty | Description Comments | Technical Specification |
|------|-------------|-----|------------------------------------|-------------------------|
| | | | ENGINE NUMBER --> 649511 | |
| 1 | 72416476 | 1 | BREATHER ><4,5 | |
| 2 | 72325449 | 2 | HEXAGONAL HEAD BOLT M8X25 | M8X25 |
| 3 | 72416477 | 1 | RUBBER-JACKET CORD | |
| 4 | 72416500 | 1 | MOLDED SEAL | |
| 5 | 72416501 | 1 | FILTER ELEMENT | |
| 6 | | | NOT USED | |

FAVORIT 714NA (714/00101-00200 & 01001-08000)
12566

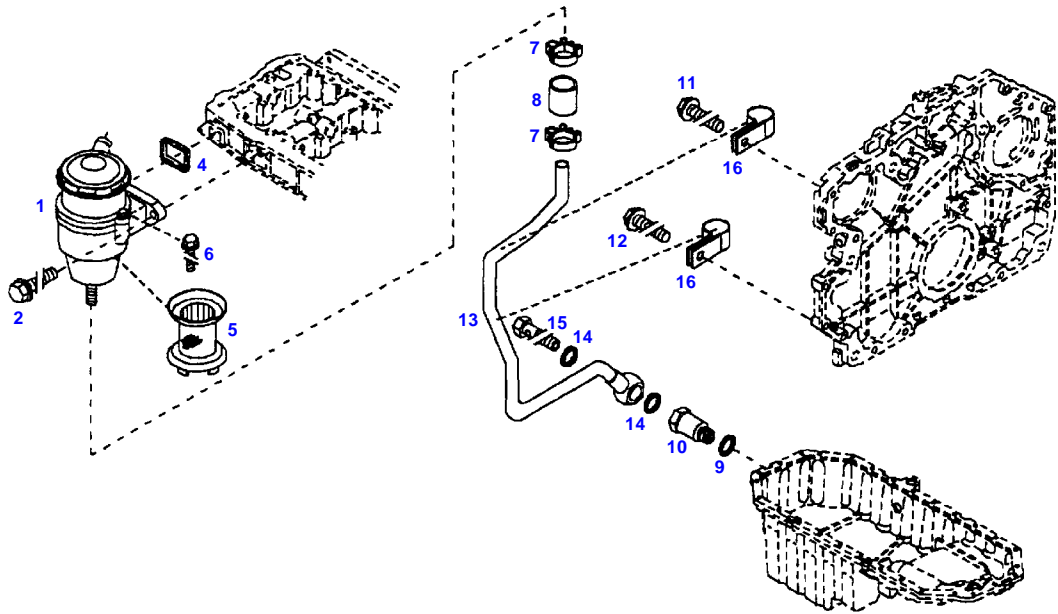

12566

| Item | Part Number | Qty | Description Comments | Technical Specification |
|------|-------------|-----|---|-------------------------|
| | | | ENGINE NUMBER <-- 649512 | |
| 1 | 72425784 | 1 | BREATHER ><4-6 <-- F718.202.210.130 | |
| 2 | 72325449 | 2 | HEXAGONAL HEAD BOLT M8X25 | M8X25 |
| 4 | 72416500 | 1 | MOLDED SEAL | |
| 5 | 72425767 | 1 | FILTER ELEMENT | |
| 6 | 72425768 | 2 | HEXAGONAL HEAD BOLT M5X20 | |
| 7 | 72325537 | 2 | HOSE CLIP | |
| 8 | 72425769 | 1 | THIMBLE | |
| 9 | 72315101 | 1 | SEALING WASHER | DIN 7603 A22X27-CU |
| 10 | 72425770 | 1 | LOCK VALVE | |
| 11 | 72325453 | 1 | HEXAGONAL HEAD BOLT M8X50 | |
| 12 | 72325457 | 1 | HEXAGONAL HEAD BOLT M8X40 | |
| 13 | 72425771 | 1 | BREATHER LINE ><14-16 | |
| 14 | 72416578 | 2 | SEALING WASHER | |
| 15 | 72323517 | 1 | BANJO BOLT | |
| 16 | 72425772 | 2 | PIPE CLAMP | |

FAVORIT 714NA (714/00101-00200 & 01001-08000)
30399

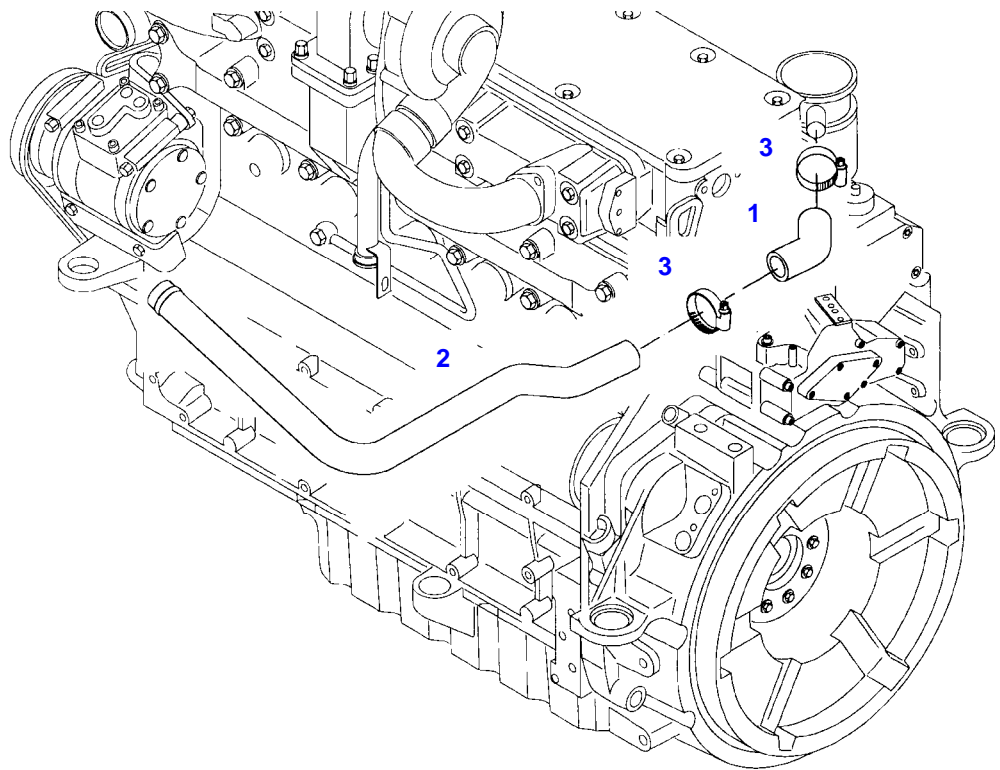

6660E0

Fendt

FAVORIT 714NA (714/00101-00200 & 01001-08000)

F714105

CRANKCASE BREATHER

Page01-0014

| Item | Part Number | Qty | Description Comments |
|------|-------------|-----|-------------------------|
| | | | PIPE |
| 1 | 72318111 | 1 | RUBBER ARCH |
| 2 | 72318112 | 1 | PIPE |
| 3 | 72311167 | 2 | HOSE CLIP |

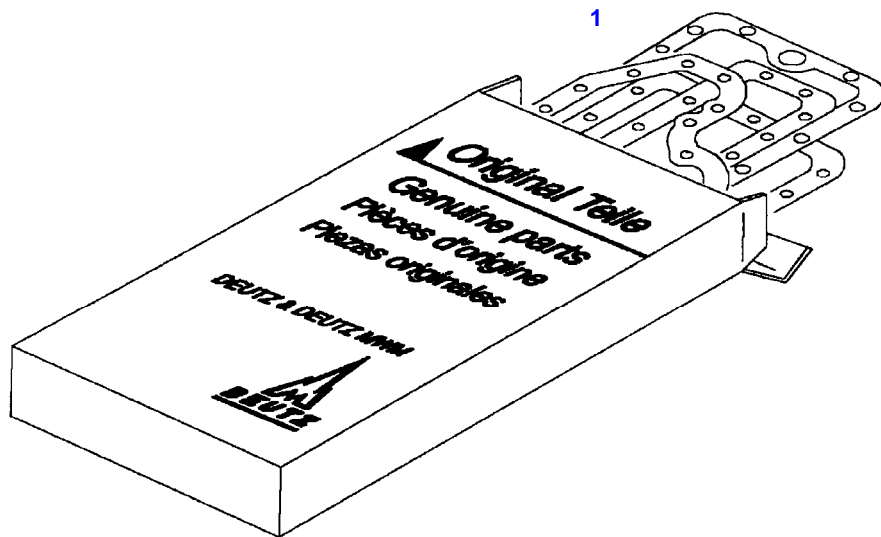

030100

| Item | Part Number | Qty | Description Comments |
|------|-------------|-----|--|
| | | | ENGINE |
| 1 | 72487669 | 1 | SEAL KIT WITHOUT CYLINDER HEAD GASKET FOR VALVE COVER ALUMINIUM ENG.NO. --> 559804 |
| | 72487673 | 1 | SEAL KIT WITHOUT CYLINDER HEAD GASKET FOR VALVE COVER PLASTIC ENG.NO. <-- 559805 |

FAVORIT 714NA (714/00101-00200 & 01001-08000)
40475

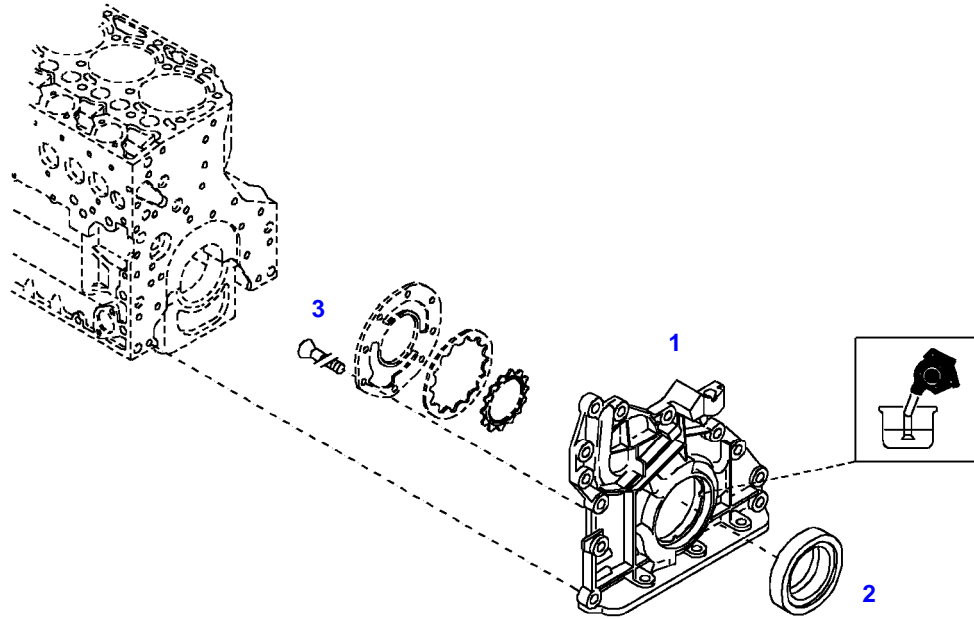

040475

| Item | Part Number | Qty | Description Comments |
|------|-------------|-----|---|
| | | | INTEGRATED OIL PUMP |
| 1 | 72479485 | 1 | CRANKCASE END COVER INTEGRATED OIL PUMP ><2,3 |
| 2 | 72479487 | 1 | SHAFT SEAL |
| 3 | 72416228 | 8 | COUNTERSUNK CAPSCREW M8X16 |

FAVORIT 714NA (714/00101-00200 & 01001-08000)
41308

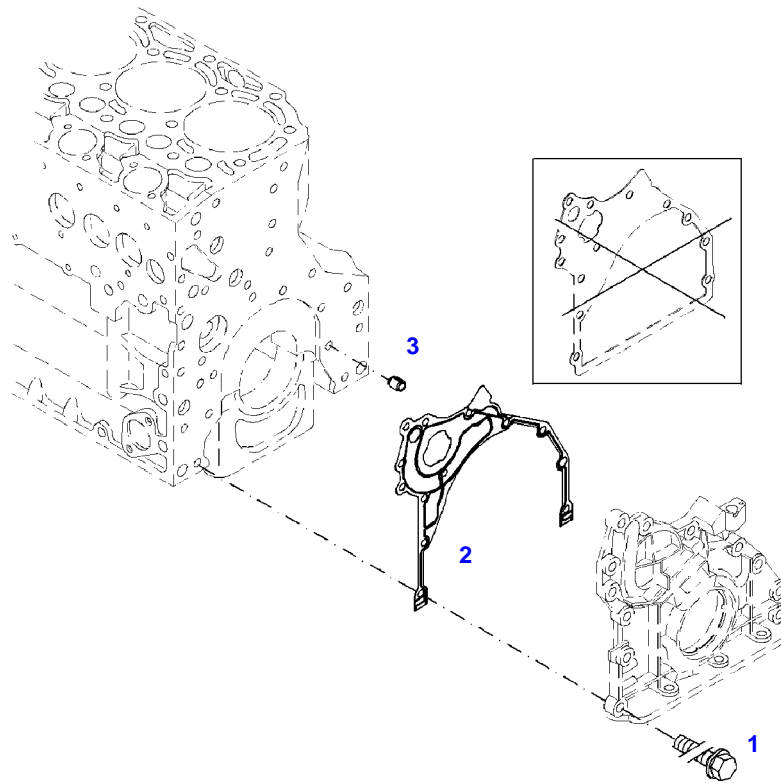

041308

Fendt

FAVORIT 714NA (714/00101-00200 & 01001-08000)

F714105

FRONT COVER

Page01-0017

| Item | Part Number | Qty | Description Comments | Technical Specification |
|-------------------|-------------|-----|------------------------------|-------------------------|
| FASTENINGS | | | | |
| 1 | 72605244 | 10 | HEXAGONAL HEAD BOLT M8X35 | M8X35 |
| 2 | 72486511 | 1 | SEAL | |
| 3 | 72325352 | 1 | TENSIONER BUSHING | |



Suggest:

For more complete manuals. Please go to the home page.

<https://www.ebooklibonline.com>

If the above button click is invalid. Please download this document first, and then click the above link to download the complete manual.

Thank you so much for reading

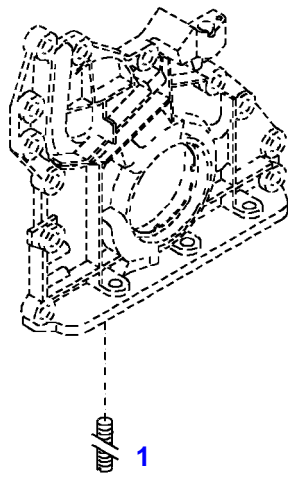

185

040503

Fendt

FAVORIT 714NA (714/00101-00200 & 01001-08000)

F714105

FRONT COVER

Page01-0018

| Item | Part Number | Qty | Description Comments |
|------|-------------|-----|---|
| | | | BLANKING PARTS ENGINE NUMBER <-- 416529 --> 529564 |
| 1 | 72416230 | 1 | THREADED PIN M8X14 |
| 185 | 72325403 | 1 | SAFE.LOCK AGENT |

<https://www.ebooklibonline.com>

Hello dear friend!

Thank you very much for reading.

Enter the link into your browser.

The full manual is available for immediate download.

<https://www.ebooklibonline.com>